



ON Semiconductor®

<http://onsemi.com>

LV56831P

Monolithic Linear IC

Multi Voltage Regulator IC for Car Audio Systems

Overview

The LV56831P has 4 system regulator, V_{DD} 5V(3.3V), AUDIO(8.5V), AMP remote(12V) and REG(3.3V/5V select). About protection circuits, it has Over-current-protection, Over-voltage-protection and Thermal-shut-down. AMP remote and REG supply is independent terminal from V_{CC} .

Features

- 4 system regulator
 - V_{DD} (LCD micon) : V_{OUT} 5.0V(3.3V), I_O max 300mA, reverse current prevention.
 - Audio : V_{OUT} 8.5V, I_O max 400mA
 - AMP remote : V_{OUT} 12V, I_O max 500mA
 - REG3.3/5V : V_{OUT} 3.3V(5V), I_O max 500mA
- Over-current-protection
- Thermal-shut-down Typ 175°C
- Over-voltage-protection: Typ 21V(except V_{DD})
- Applied Pch-LDMOS for output stages.

(Warning)The protector functions only improve the IC's tolerance and they do not guarantee the safety of the IC if used under the conditions out of safety range or ratings. Use of the IC such as use under overcurrent protection range or thermal shut down state may degrade the IC's reliability and eventually damage the IC.

Specifications

Absolute Maximum Ratings at $T_a = 25^\circ\text{C}$

Parameter	Conditions	Conditions	Ratings	Unit
Supply voltage	V_{CC} max		36	V
Allowable Power dissipation	P_d max (* $T_a \leq 25^\circ\text{C}$)	IC unit	1.3	W
		With Al heatsink(50x50x1.5mm ³)	5.3	W
		Infinite heat radiation	26	W
Peak supply voltage	V_{CC} peak	See below pulse wave.	50	V
Operating ambient temperature	T_{opr}		-40 to +85	°C
Storage temperature	T_{stg}		-55 to +150	°C
Junction temperature	T_j max		150	°C

Stresses exceeding Maximum Ratings may damage the device. Maximum Ratings are stress ratings only. Functional operation above the Recommended Operating Conditions is not implied. Extended exposure to stresses above the Recommended Operating Conditions may affect device reliability.

LV56831P

Peak voltage testing pulse wave

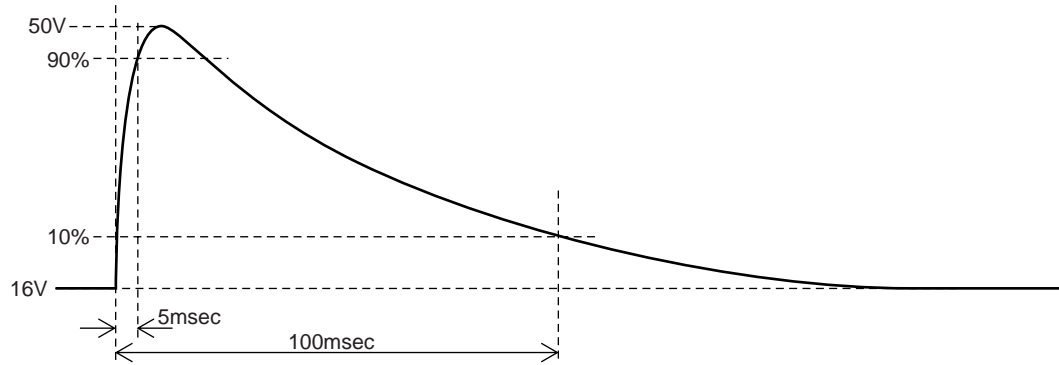

Recommended Operating condition at Ta = 25°C

Parameter	Conditions	Ratings	Unit
Power supply voltage rating 1	V _{DD} output(5V/3.3V)	7 to 16	V
Power supply voltage rating 2	REG output(5V/3.3V): V _{CC} =V _{CC1}	7 to 16	V
Power supply voltage rating 3	AUDIO output	11 to 16	V
Power supply voltage rating 4	AMP remote output: V _{CC} =V _{CC1}	13 to 16	V

Electrical Characteristics at Ta = 25°C, V_{CC} = V_{CC1} = 14.4V (*1)

Parameter	Symbol	Conditions	Ratings			Unit
			min	typ	max	
Quiescent current	I _{CC}	V _{DD} no load, ALL EN terminal = [L]		50	100	μA
AUDIO_EN Input						
Low input voltage	V _{IL1}		0		0.5	V
High input voltage	V _{IH1}		2.0		5.5	V
Input impedance	R _{IH1}		280	400	520	kΩ
AMP_EN Input						
Low input voltage	V _{IL2}		0		0.5	V
High input voltage	V _{IH2}		2.0		5.5	V
Input impedance	R _{IH2}		280	400	520	kΩ
REG_EN input						
Low input voltage	V _{IL3}		0		0.5	V
High input voltage	V _{IH3}		2.0		5.5	V
Input impedance	R _{IH3}		280	400	520	kΩ
V_{DD} (5V/3.3V)output(reverse current prevention diode implemented)						
V _{DD} output voltage 1	V _{O11}	I _{O11} = 200mA, I _{KV_{DD}} is connected to 5PIN.	4.75	5.0	5.25	V
V _{DD} output current 1	I _{O11}	V _{O11} ≥ 4.7V	300			mA
V _{DD} output voltage 2	V _{O12}	I _{O12} = 200mA, I _{KV_{DD}} =GND	3.13	3.3	3.47	V
V _{DD} output current 2	I _{O12}	V _{O12} ≥ 3.1V	300			mA
Line regulation	ΔV _{OLN1}	7V < V _{CC} < 16V, I _{O1} = 200mA		50	100	mV
Load regulation	ΔV _{OLD1}	1mA < I _{O11} , I _{O12} < 200mA		80	150	mV
Dropout voltage 1	V _{DROP1}	I _{O1} = 200mA (implemented diode)		1.5	2.5	V
V _{CC} ripple rejection	R _{REJ1}	f=120Hz, I _{O1} =200mA	40(*2)	50(*2)		dB
V _{DD} reverse current	I _{REV}	V _{O11} =5.0V, V _{CC} =0V		10	100	μA
AMP remote output ; AMP_EN = High						
USB output voltage 1	V _{O2}	I _{O2} = 400mA	11.4	12	12.6	V
USB output current 1	I _{O2}	V _{O2} ≥ 11.3V	500			mA
Line regulation	ΔV _{OLN2}	13V < V _{CC1} < 16V, I _{O2} = 400mA		50	100	mV
Load regulation	ΔV _{OLD2}	10mA < I _{O2} < 400mA		80	160	mV
Dropout voltage 1	V _{DROP2}	I _{O2} = 400mA		0.4	0.8	V
V _{CC1} ripple rejection	R _{REJ2}	f=120Hz, I _{O2} =400mA	40(*2)	50(*2)		dB

Continued on next page.

LV56831P

Continued from preceding page.

Parameter	Symbol	Conditions	Ratings			Unit
			min	typ	max	
AUDIO output ; AUDIO_EN = High						
AUDIO output voltage	V_{O3}	$I_{O3} = 300\text{mA}$	8.1	8.5	8.9	V
AUDIO output current	I_{O3}	$V_{O3} \geq 8\text{V}$	400			mA
Line regulation	ΔV_{OLN3}	$10\text{V} < V_{CC} < 16\text{V}$, $I_{O3} = 300\text{mA}$		30	100	mV
Load regulation	ΔV_{OLD3}	$1\text{mA} < I_{O3} < 300\text{mA}$		70	140	mV
Dropout voltage	V_{DROP3}	$I_{O3} = 300\text{mA}$		0.6	1.05	V
V_{CC} ripple rejection	R_{REJ3}	$f = 120\text{Hz}$, $I_{O3} = 300\text{mA}$	40(*2)	50(*2)		dB
REG (3.3V/5V) Output ; REG_EN = High						
REG output voltage 1	V_{O41}	$I_{O41} = 400\text{mA}$, IKREG is connected to 10PIN.	4.75	5	5.25	V
REG output current 1	I_{O41}	$V_{O41} \geq 4.7\text{V}$	500			mA
REG output voltage 2	V_{O42}	$I_{O42} = 400\text{mA}$, IKREG=GND	3.13	3.3	3.47	V
REG output current 2	I_{O42}	$V_{O42} \geq 3.1\text{V}$	500			mA
Line regulation	ΔV_{OLN4}	$7\text{V} < V_{CC1} < 16\text{V}$, $I_{O4} = 400\text{mA}$		30	100	mV
Load regulation	ΔV_{OLD4}	$1\text{mA} < I_{O4} < 400\text{mA}$		80	150	mV
Dropout voltage	V_{DROP4}	$I_{O4} = 400\text{mA}$		1.0	1.5	V
V_{CC1} ripple rejection	R_{REJ4}	$f = 120\text{Hz}$, $I_{O4} = 400\text{mA}$	40(*2)	50(*2)		dB

*1: The entire specification has been defined based on the tests performed under the conditions where T_j and $T_a (=25^\circ\text{C})$ are almost equal. There tests were performed with pulse load to minimize the increase of junction temperature(T_j).

*2 : design certification

Package Dimensions

unit : mm (typ)

3336

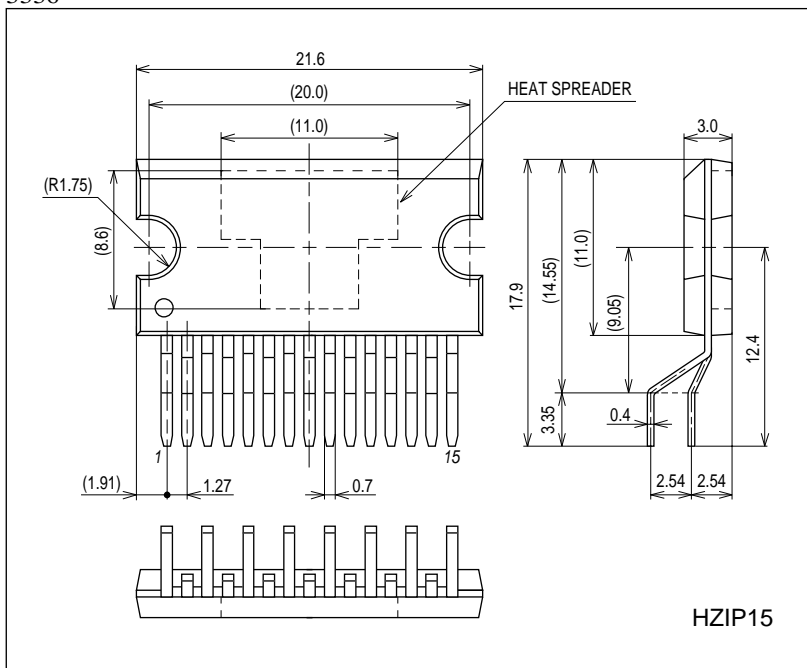

Pin assignment

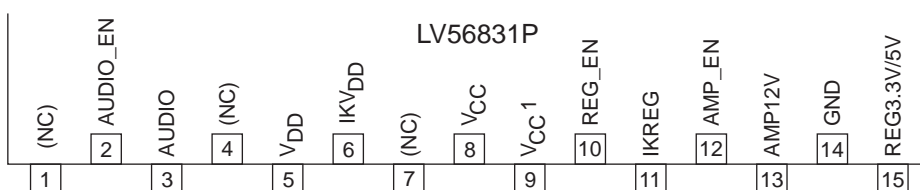

LV56831P

Allowable power dissipation derating curve

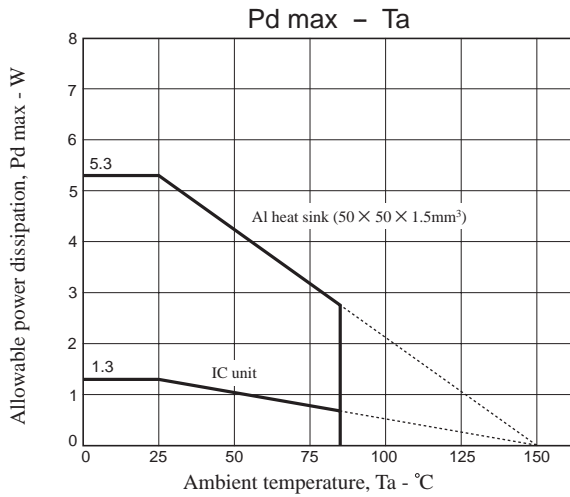

- (a) IC unit(HZIP15)
 - (b) With Al heatsink(50×50×1.5mm³)
- Al heatsink mounting conditions
Tightening torque: 39N-cm, using silicone grease

Block Diagram

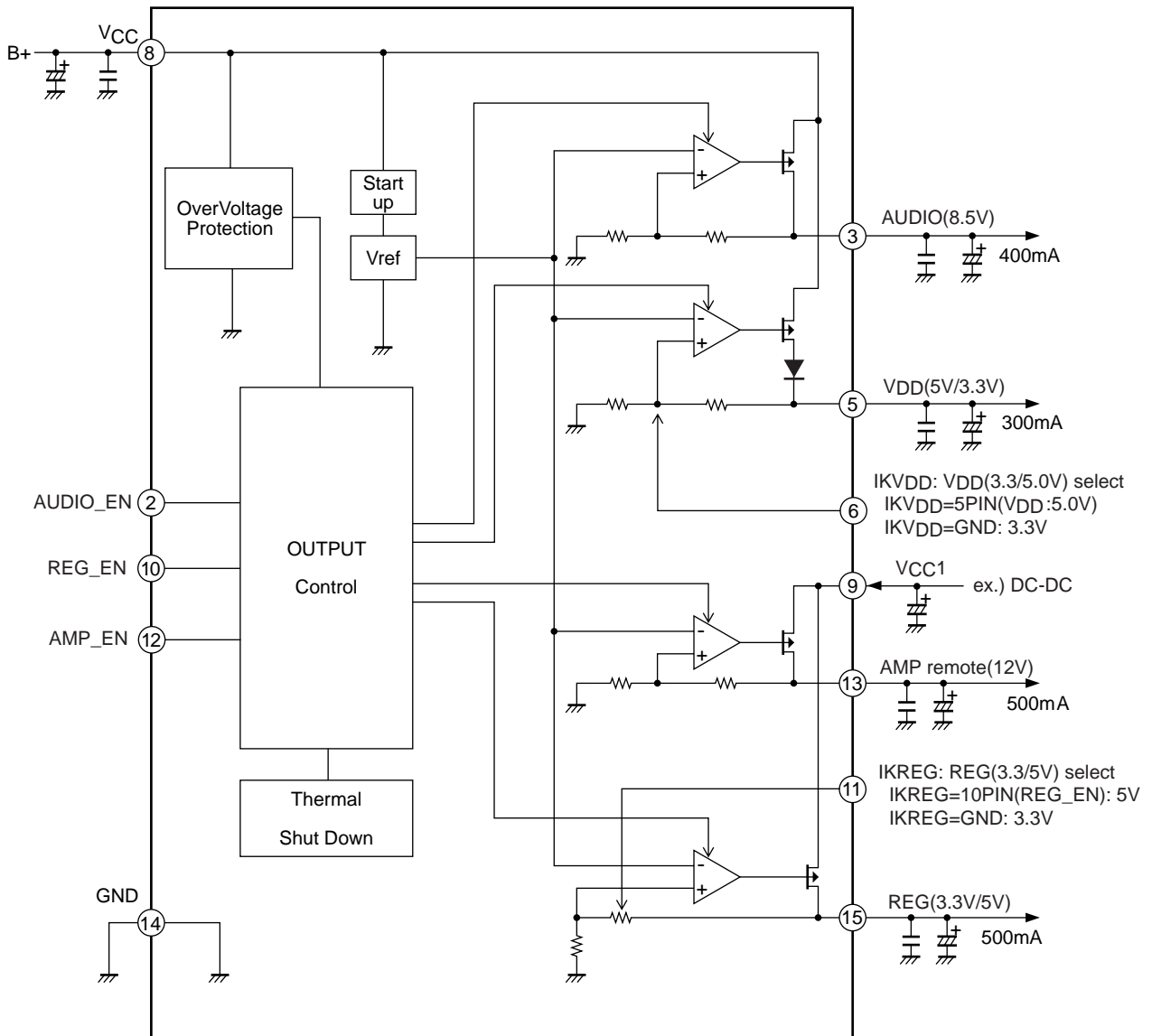

LV56831P

Pin Function

Pin No.	Pin name	Description	Equivalent Circuit
1	N.C.	-	-
2	AUDIO_EN	AUDIO output CTRL	
3	AUDIO	AUDIO output when AUDIO_EN = High, ON 8.5V/0.4A	
4	N.C.	-	-
5	V _{DD}	V _{DD} output 5.0V, 3.3V/0.3A	
6	IKV _{DD}	V _{DD} output voltage select OPEN : V _{DD} = 5.0V GND : V _{DD} = 3.3V	
7	N.C.	-	-
8	V _{CC}	V _{CC}	
9	V _{CC1}	V _{CC1}	

Continued on next page.

LV56831P

Continued from preceding page.

Pin No.	Pin name	Description	Equivalent Circuit
10	REG_EN	REG output CTRL	
11	IKREG	REG output voltage select OPEN : REG = 3.3V GND : REG = 5.0V	
12	AMP_EN	AMP output CTRL	
13	AMP	AMP output when AMP_EN = High, ON 12V, 0.5A	
14	GND	GND	
15	REG	REG output when REG_EN = High, ON 5.0V, 3.3V/0.5A	

LV56831P

Timing Chart

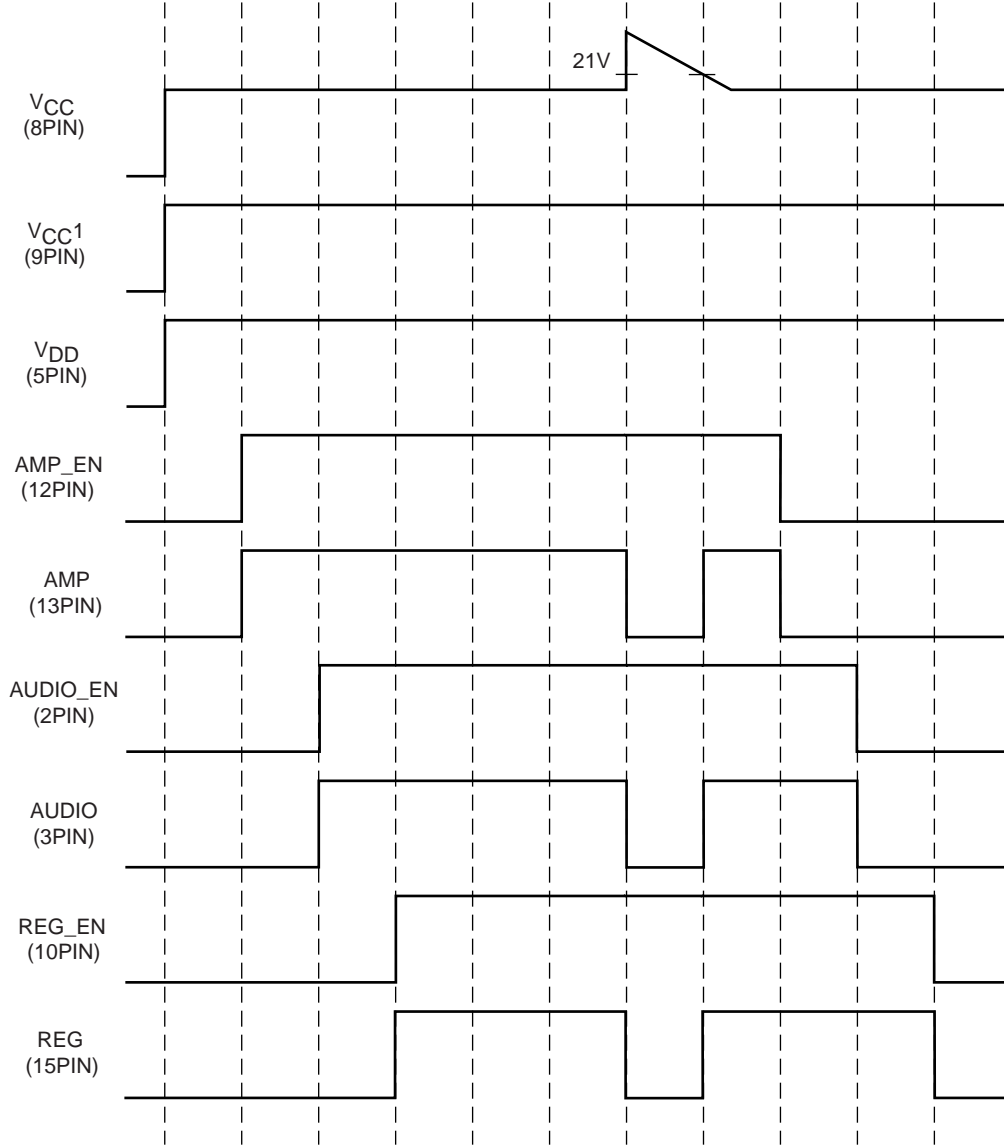

HZIP15 Heat sink attachment

Heat sinks are used to lower the semiconductor device junction temperature by leading the heat generated by the device to the outer environment and dissipating that heat.

- a. Unless otherwise specified, for power ICs with tabs and power ICs with attached heat sinks, solder must not be applied to the heat sink or tabs.

b. Heat sink attachment

- Use flat-head screws to attach heat sinks.
- Use also washer to protect the package.
- Use tightening torques in the ranges 39-59Ncm(4-6kgcm) .
- If tapping screws are used, do not use screws with a diameter larger than the holes in the semiconductor device itself.
- Do not make gap, dust, or other contaminants to get between the semiconductor device and the tab or heat sink.
- Take care a position of via hole .
- Do not allow dirt, dust, or other contaminants to get between the semiconductor device and the tab or heat sink.
- Verify that there are no press burrs or screw-hole burrs on the heat sink.
- Warping in heat sinks and printed circuit boards must be no more than 0.05 mm between screw holes, for either concave or convex warping.
- Twisting must be limited to under 0.05 mm.
- Heat sink and semiconductor device are mounted in parallel.
Take care of electric or compressed air drivers
- The speed of these torque wrenches should never exceed 700 rpm, and should typically be about 400 rpm.

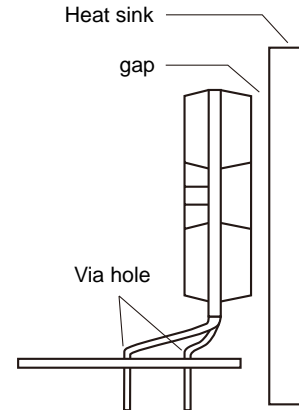
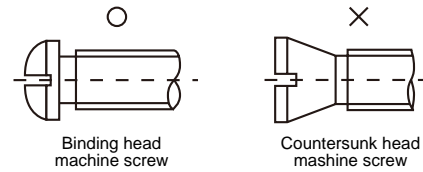

c. Silicone grease

- Spread the silicone grease evenly when mounting heat sinks.
- Our company recommends YG-6260 (Momentive Performance Materials Japan LLC)

d. Mount

- First mount the heat sink on the semiconductor device, and then mount that assembly on the printed circuit board.
- When attaching a heat sink after mounting a semiconductor device into the printed circuit board, when tightening up a heat sink with the screw, the mechanical stress which is impossible to the semiconductor device and the pin doesn't hang.

e. When mounting the semiconductor device to the heat sink using jigs, etc.,

- Take care not to allow the device to ride onto the jig or positioning dowel.
- Design the jig so that no unreasonable mechanical stress is not applied to the semiconductor device.

f. Heat sink screw holes

- Be sure that chamfering and shear drop of heat sinks must not be larger than the diameter of screw head used.
- When using nuts, do not make the heat sink hole diameters larger than the diameter of the head of the screws used. A hole diameter about 15% larger than the diameter of the screw is desirable.
- When tap screws are used, be sure that the diameter of the holes in the heat sink are not too small. A diameter about 15% smaller than the diameter of the screw is desirable.

- g. There is a method to mount the semiconductor device to the heat sink by using a spring band. But this method is not recommended because of possible displacement due to fluctuation of the spring force with time or vibration.

ON Semiconductor and the ON logo are registered trademarks of Semiconductor Components Industries, LLC (SCILLC). SCILLC owns the rights to a number of patents, trademarks, copyrights, trade secrets, and other intellectual property. A listing of SCILLC's product/patent coverage may be accessed at www.onsemi.com/site/pdf/Patent-Marking.pdf. SCILLC reserves the right to make changes without further notice to any products herein. SCILLC makes no warranty, representation or guarantee regarding the suitability of its products for any particular purpose, nor does SCILLC assume any liability arising out of the application or use of any product or circuit, and specifically disclaims any and all liability, including without limitation special, consequential or incidental damages. "Typical" parameters which may be provided in SCILLC data sheets and/or specifications can and do vary in different applications and actual performance may vary over time. All operating parameters, including "Typicals" must be validated for each customer application by customer's technical experts. SCILLC does not convey any license under its patent rights nor the rights of others. SCILLC products are not designed, intended, or authorized for use as components in systems intended for surgical implant into the body, or other applications intended to support or sustain life, or for any other application in which the failure of the SCILLC product could create a situation where personal injury or death may occur. Should Buyer purchase or use SCILLC products for any such unintended or unauthorized application, Buyer shall indemnify and hold SCILLC and its officers, employees, subsidiaries, affiliates, and distributors harmless against all claims, costs, damages, and expenses, and reasonable attorney fees arising out of, directly or indirectly, any claim of personal injury or death associated with such unintended or unauthorized use, even if such claim alleges that SCILLC was negligent regarding the design or manufacture of the part. SCILLC is an Equal Opportunity/Affirmative Action Employer. This literature is subject to all applicable copyright laws and is not for resale in any manner.

X-ON Electronics

Largest Supplier of Electrical and Electronic Components

Click to view similar products for [Linear Voltage Regulators](#) category:

Click to view products by [ON Semiconductor](#) manufacturer:

Other Similar products are found below :

[LV56831P-E](#) [LV5684PVD-XH](#) [MCDTSA6-2R](#) [L7815ACV-DG](#) [LV56801P-E](#) [TCR3DF13,LM\(CT](#) [TCR3DF39,LM\(CT](#) [TLE42794G](#)
[L78L05CZ/1SX](#) [L78LR05DL-MA-E](#) [LM317T](#) [636416C](#) [714954EB](#) [LV5680P-E](#) [L78M15CV-DG](#) [L79M05T-E](#) [TLS202A1MBVHTSA1](#)
[L78LR05D-MA-E](#) [NCV317MBTG](#) [NTE7227](#) [NCV78M09BDTRKG](#) [LV5680NPVC-XH](#) [LT1054CN8](#) [ME6208A50M3G](#) [SL7533-8](#)
[ME6231A50M3G](#) [ME6231A50PG](#) [ME6231C50M5G](#) [AMS1117S-3.3](#) [AMS1117-5.0](#) [AMS1117S-5.0](#) [AMS1117-3.3](#) [MD5118](#) [MD5121](#)
[MD5127](#) [MD5128](#) [MD5130](#) [MD5144](#) [MD5150](#) [MD5115](#) [MD5125](#) [MD5133](#) [MD5136](#) [MD5140](#) [MD5110](#) [MD52E18WB6](#) [MD52E33WB6](#)
[MD52E15QA3](#) [MD52E21QA3](#) [MD52E25QA3](#)