



ON Semiconductor®

<http://onsemi.com>

LV5683P

Bi-CMOS IC

Multi Voltage Regulator IC for Car Audio Systems

Overview

The LV5683P is a multi voltage regulator suitable for USB silicon tuner car-audio systems.

This IC has 4 outputs, V_{DD} 5V(3.3V), AUDIO(8.5V), SWU(3.3V) and USB5V(CD 8V: available).

About protection circuits, it has Over-current-protection, Over-voltage-protection and Thermal-shut-down.

V_{CC1} (SWU and USB supply) is independent terminal from V_{CC} , and accepts lower voltage (ex. From DC/DC converter) which enables to reduce power dissipation.

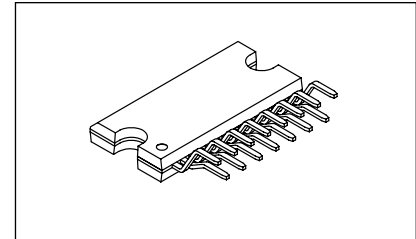

HZIP15

Features

- 4 system regulator
 - V_{DD} (LCD micon) : V_{OUT} 5.0V(3.3V), I_O max 300mA, reverse current prevention.
 - Audio : V_{OUT} 8.5V, I_O max 400mA
 - SWU(systems) : V_{OUT} 3.3V, I_O max 500mA
 - USB : V_{OUT} 5.0V(8.0V available for CD), I_O max 1100mA
- Over-current-protection
- Thermal-shut-down Typ 175°C
- Over-voltage-protection: Typ 21V(except V_{DD})
- Applied Pch-LDMOS for output stages.

(Warning)The protector functions only improve the IC's tolerance and they do not guarantee the safety of the IC if used under the conditions out of safety range or ratings. Use of the IC such as use under overcurrent protection range or thermal shut down state may degrade the IC's reliability and eventually damage the IC.

Specifications

Absolute Maximum Ratings at $T_a = 25^\circ\text{C}$

Parameter	Conditions	Conditions	Ratings	Unit
Supply voltage	V_{CC} max		36	V
Allowable Power dissipation	P_d max (* $T_a \leq 25^\circ\text{C}$)	IC unit	1.3	W
		With Al heatsink(50×50×1.5mm ³)	5.3	W
		Infinite heat radiation	26	W
Peak supply voltage	V_{CC} peak	See below pulse wave.	50	V
Operating ambient temperature	T_{opr}		-40 to +85	°C
Storage temperature	T_{stg}		-55 to +150	°C
Junction temperature	T_j max		150	°C

Stresses exceeding Maximum Ratings may damage the device. Maximum Ratings are stress ratings only. Functional operation above the Recommended Operating Conditions is not implied. Extended exposure to stresses above the Recommended Operating Conditions may affect device reliability.

ORDERING INFORMATION

See detailed ordering and shipping information on page 10 of this data sheet.

LV5683P

Peak voltage testing pulse wave

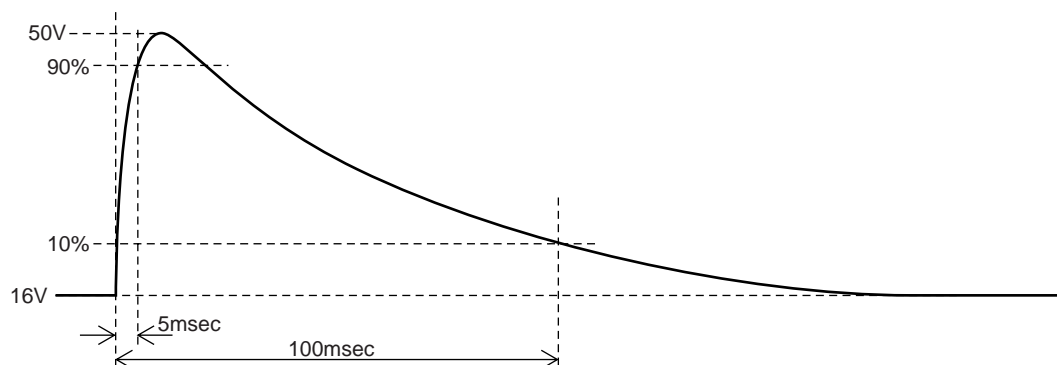

Recommended Operating condition at Ta = 25°C

Parameter	Conditions	Ratings	Unit
Power supply voltage rating 1	V _{DD} output(5V/3.3V)	7 to 16	V
Power supply voltage rating 2	USB(5V) output, SWU output: V _{CC} =V _{CC1}	7.5 to 16	V
Power supply voltage rating 3	AUDIO output	10 to 16	V
Power supply voltage rating 4	USB(8V) output: V _{CC} =V _{CC1}	10.5 to 16	V

Electrical Characteristics at Ta = 25°C, V_{CC} = V_{CC1} = 14.4V (*1)

Parameter	Symbol	Conditions	Ratings			Unit
			min	typ	max	
Quiescent current	I _{CC}	V _{DD} no load, ALL EN terminal = [L]		50	100	μA
AUDIO_EN Input						
Low input voltage	V _{IL1}		0		0.5	V
High input voltage	V _{IH1}		2.8		5.5	V
Input impedance	R _{IN1}		280	400	520	kΩ
SWU_EN Input						
Low input voltage	V _{IL2}		0		0.5	V
High input voltage	V _{IH2}		2.8		5.5	V
Input impedance	R _{IN2}		280	400	520	kΩ
USB_EN input						
Low input voltage	V _{IL3}		0		0.5	V
High input voltage	V _{IH3}		2.8		5.5	V
Input impedance	R _{IN3}		280	400	520	kΩ
V_{DD} (5V/3.3V)output(reverse current prevention diode implemented)						
V _{DD} output voltage 1	V _{O11}	I _{O11} = 200mA, IKV _{DD} =OPEN, or V _{DD} out	4.75	5.0	5.25	V
V _{DD} output current 1	I _{O11}	V _{O11} ≥ 4.7V	300			mA
V _{DD} output voltage 2	V _{O12}	I _{O12} = 200mA, IKV _{DD} =GND	3.13	3.3	3.47	V
V _{DD} output current 2	I _{O12}	V _{O12} ≥ 3.1V	300			mA
Line regulation	ΔV _{OLN1}	7V < V _{CC} < 16V, I _{O1} = 200mA		50	100	mV
Load regulation	ΔV _{OLD1}	1mA < I _{O11} , I _{O12} < 200mA		80	150	mV
Dropout voltage 1	V _{DROP1}	I _{O1} = 200mA (implemented diode)		1.5	2.5	V
V _{CC} ripple rejection	R _{REJ1}	f=120Hz, V _{CC} =1V _{PP} , I _{O1} =200mA	40(*2)	50(*2)		dB
V _{DD} reverse current	I _{REV}	V _{O11} =5.0V, V _{CC} =0V		10	100	μA
USB/CD output ; USB_EN = High						
USB output voltage 1	V _{O21}	I _{O21} = 1000mA, IKUSB=OPEN, or USBout	7.6	8.0	8.4	V
USB output current 1	I _{O21}	V _{O21} ≥ 7.45V	1100			mA
USB output voltage 2	V _{O22}	I _{O22} = 1000mA, IKUSB=GND	4.75	5.0	5.25	V
USB output current 2	I _{O22}	V _{O22} ≥ 4.6V	1100			mA
Line regulation	ΔV _{OLN2}	10.5V < V _{CC1} < 16V, I _{O2} = 1000mA		50	100	mV
Load regulation	ΔV _{OLD2}	10mA < I _{O21} , I _{O22} < 1000mA		100	200	mV
Dropout voltage	V _{DROP2}	I _{O21} , I _{O22} = 1000mA		1.0	2.0	V
V _{CC1} ripple rejection	R _{REJ2}	f=120Hz, V _{CC1} =1V _{PP} , I _{O2} =1000mA	40(*2)	50(*2)		dB

Continued on next page.

LV5683P

Continued from preceding page.

Parameter	Symbol	Conditions	Ratings			Unit
			min	typ	max	
AUDIO output ; AUDIO_EN = High						
AUDIO output voltage	V_{O3}	$I_{O3} = 300\text{mA}$	8.1	8.5	8.9	V
AUDIO output current	I_{O3}	$V_{O3} \geq 8\text{V}$	400			mA
Line regulation	ΔV_{OLN3}	$10\text{V} < V_{CC} < 16\text{V}, I_{O3} = 300\text{mA}$		30	100	mV
Load regulation	ΔV_{OLD3}	$1\text{mA} < I_{O3} < 300\text{mA}$		70	140	mV
Dropout voltage	V_{DROP3}	$I_{O3} = 300\text{mA}$		0.6	1.05	V
V_{CC} ripple rejection	R_{REJ3}	$f = 120\text{Hz}, V_{CC} = 1\text{V}_{PP}, I_{O3} = 300\text{mA}$	40(*2)	50(*2)		dB
SWU (3.3V) Output ; SEU_EN = High						
SWU output voltage	V_{O4}	$I_{O4} = 400\text{mA}$	3.13	3.3	3.47	V
SWU output current	I_{O4}	$V_{O4} \geq 3.1\text{V}$	500			mA
Line regulation	ΔV_{OLN4}	$7.5\text{V} < V_{CC} < 16\text{V}, I_{O4} = 400\text{mA}$		30	100	mV
Load regulation	ΔV_{OLD4}	$1\text{mA} < I_{O4} < 400\text{mA}$		80	150	mV
V_{CC1} ripple rejection	R_{REJ4}	$f = 120\text{Hz}, V_{CC} = 1\text{V}_{PP}, I_{O4} = 400\text{mA}$	40(*2)	50(*2)		dB

*1: The entire specification has been defined based on the tests performed under the conditions where T_j and $T_a (= 25^\circ\text{C})$ are almost equal. These tests were performed with pulse load to minimize the increase of junction temperature (T_j).

*2: design certification

Allowable power dissipation derating curve

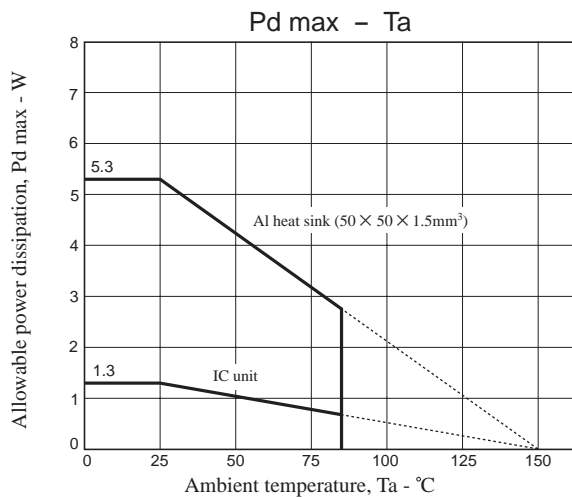

- (a) IC unit(HZIP15)
- (b) With Al heatsink($50 \times 50 \times 1.5\text{mm}^3$)
Al heatsink mounting conditions
Tightening torque: 39N·cm, using silicone grease

LV5683P

Package Dimensions

unit : mm

HZIP15

CASE 945AB

ISSUE A

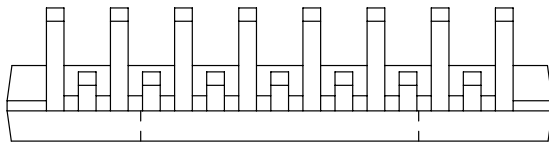
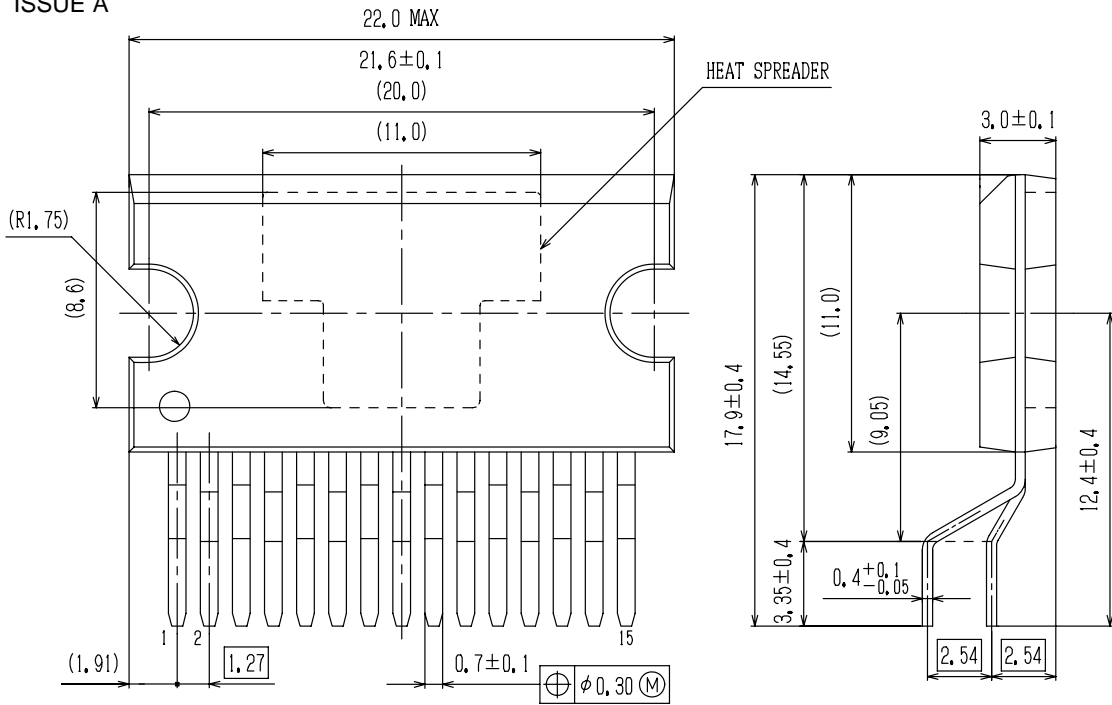

GENERIC MARKING DIAGRAM*

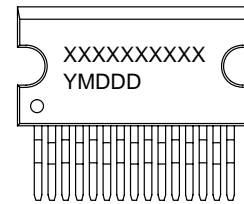

XXXXX = Specific Device Code
 Y = Year
 M = Month
 DDD = Additional Traceability Data

*This information is generic. Please refer to device data sheet for actual part marking. Pb-Free indicator, "G" or microdot "▪", may or may not be present.

SOLDERING FOOTPRINT*

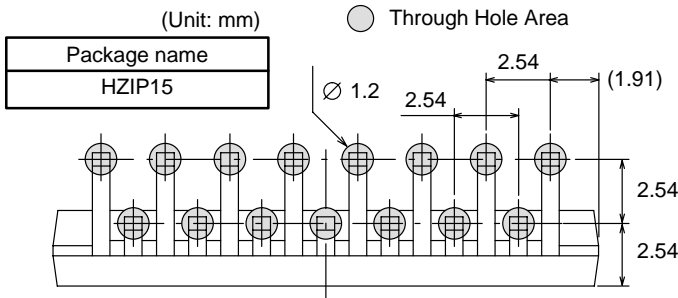

NOTE: The measurements are not to guarantee but for reference only.

*For additional information on our Pb-Free strategy and soldering details, please download the ON Semiconductor Soldering and Mounting Techniques Reference Manual, SOLDERRM/D.

LV5683P

Pin assignment

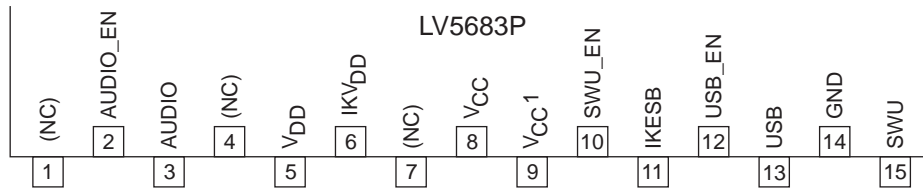

Block Diagram

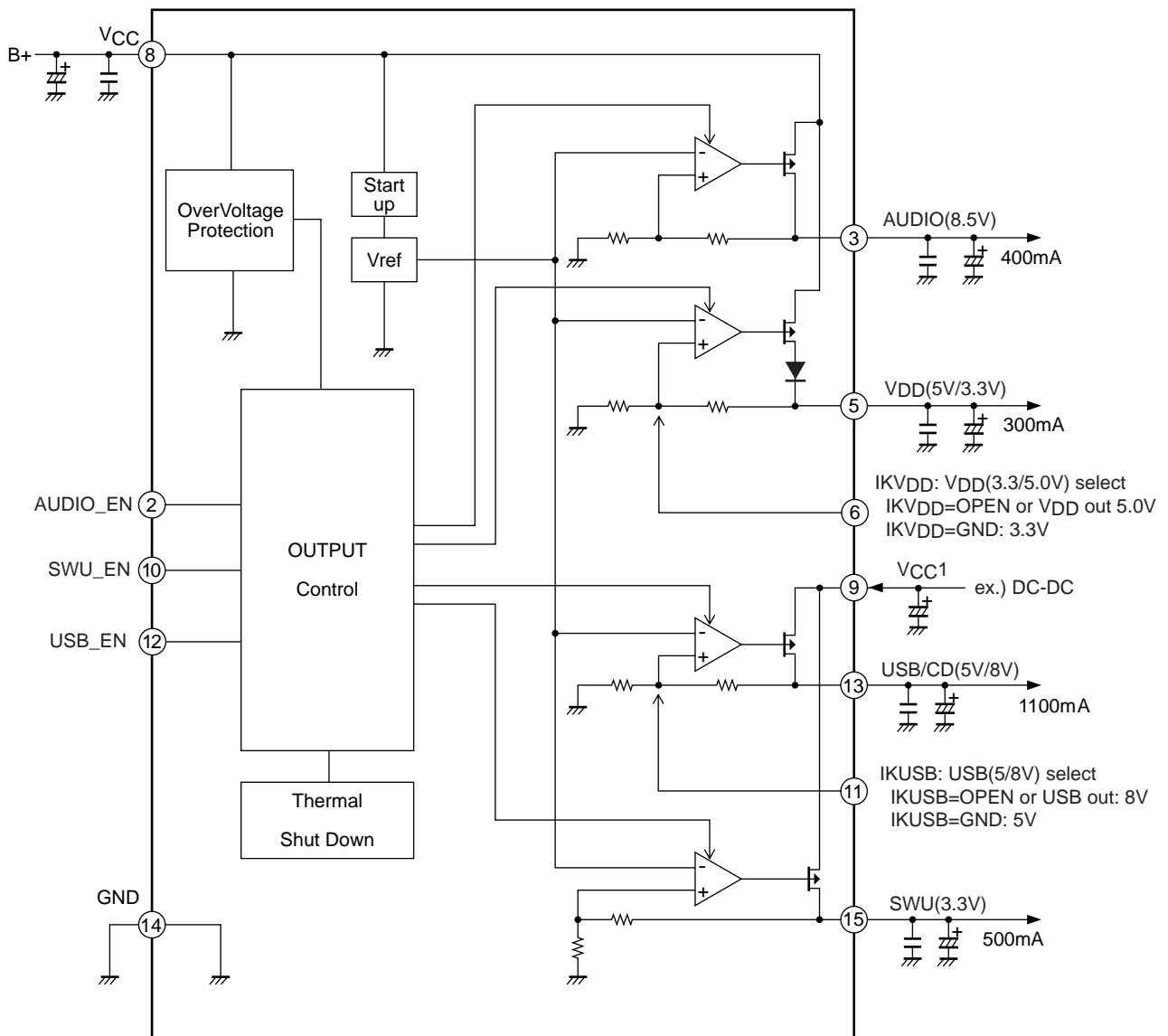

LV5683P

Pin Function

Pin No.	Pin name	Description	Equivalent Circuit
1	N.C.	-	-
2	AUDIO_EN	AUDIO output CTRL	
3	AUDIO	AUDIO output when AUDIO_EN = High, ON 8.5V/0.4A	
4	N.C.	-	-
5	V _{DD}	V _{DD} output 5.0V, 3.3V/0.3A	
6	IKV _{DD}	V _{DD} output voltage select OPEN : V _{DD} = 5.0V GND : V _{DD} = 3.3V	
7	N.C.	-	-
8	V _{CC}	V _{CC}	
9	V _{CC1}	V _{CC1}	

Continued on next page.

LV5683P

Continued from preceding page.

Pin No.	Pin name	Description	Equivalent Circuit
10	SWU_EN	SWU output CTRL	
11	IKUSB	USB output voltage select OPEN : $V_{DD} = 8.0V$ GND : $V_{DD} = 5.0V$	
12	USB_EN	USB output CTRL	
13	USB	USB output when USB_EN = High, ON 5.0V, 8.0V/1.1A	
14	GND	GND	
15	SWU	SWU output when SWU_EN = High, ON 3.3V/0.5A	

LV5683P

Timing Chart

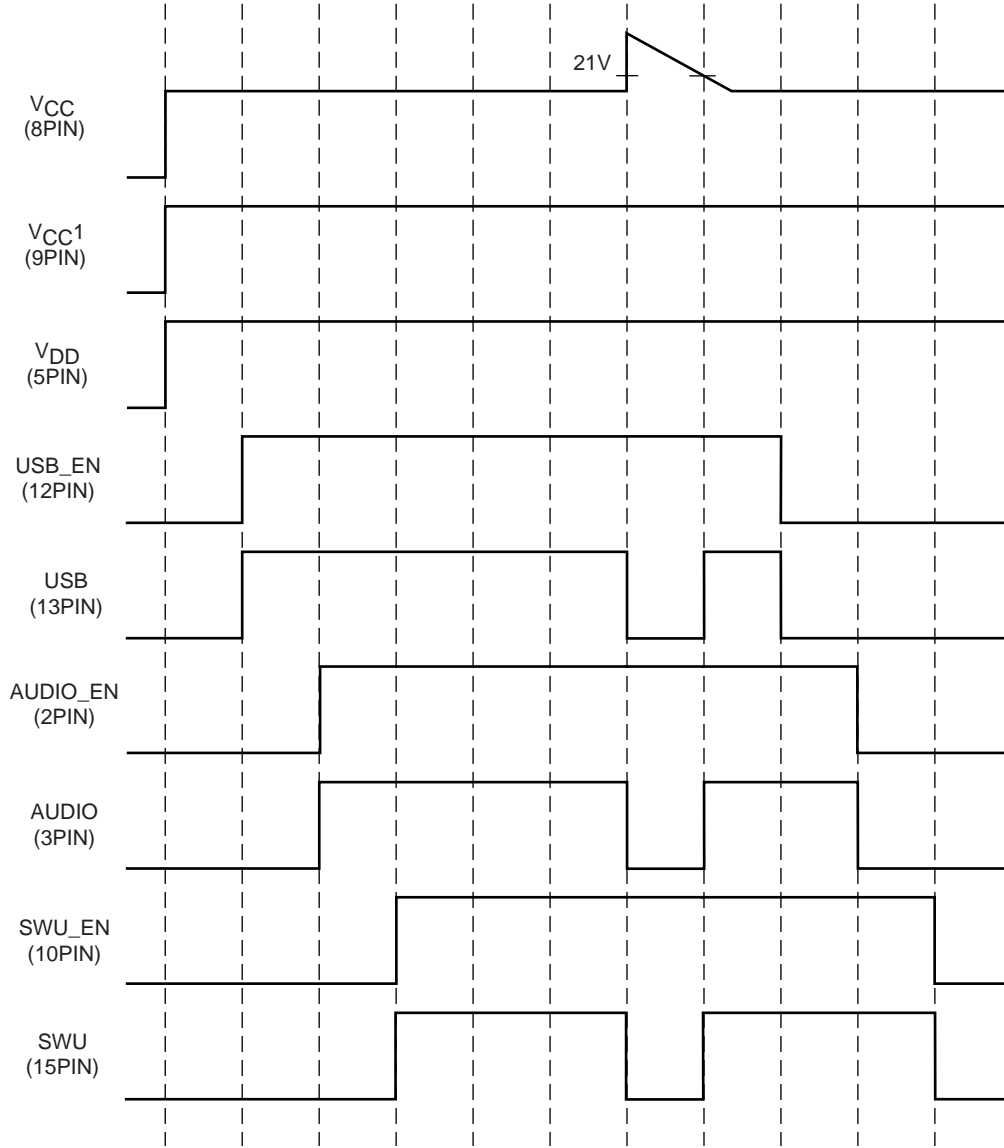

HZIP15 Heat sink attachment

Heat sinks are used to lower the semiconductor device junction temperature by leading the heat generated by the device to the outer environment and dissipating that heat.

- a. Unless otherwise specified, for power ICs with tabs and power ICs with attached heat sinks, solder must not be applied to the heat sink or tabs.

b. Heat sink attachment

- Use flat-head screws to attach heat sinks.
- Use also washer to protect the package.
- Use tightening torques in the ranges 39-59Ncm(4-6kgcm) .
- If tapping screws are used, do not use screws with a diameter larger than the holes in the semiconductor device itself.
- Do not make gap, dust, or other contaminants to get between the semiconductor device and the tab or heat sink.
- Take care a position of via hole .
- Do not allow dirt, dust, or other contaminants to get between the semiconductor device and the tab or heat sink.
- Verify that there are no press burrs or screw-hole burrs on the heat sink.
- Warping in heat sinks and printed circuit boards must be no more than 0.05 mm between screw holes, for either concave or convex warping.
- Twisting must be limited to under 0.05 mm.
- Heat sink and semiconductor device are mounted in parallel.
Take care of electric or compressed air drivers
- The speed of these torque wrenches should never exceed 700 rpm, and should typically be about 400 rpm.

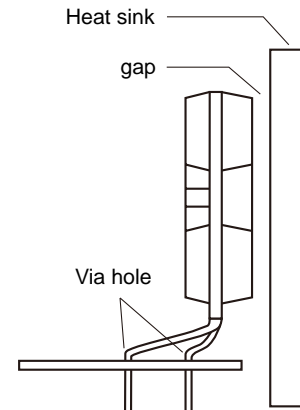
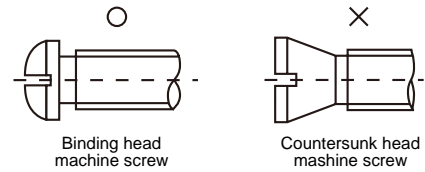

c. Silicone grease

- Spread the silicone grease evenly when mounting heat sinks.
- Our company recommends YG-6260 (Momentive Performance Materials Japan LLC)

d. Mount

- First mount the heat sink on the semiconductor device, and then mount that assembly on the printed circuit board.
- When attaching a heat sink after mounting a semiconductor device into the printed circuit board, when tightening up a heat sink with the screw, the mechanical stress which is impossible to the semiconductor device and the pin doesn't hang.

e. When mounting the semiconductor device to the heat sink using jigs, etc.,

- Take care not to allow the device to ride onto the jig or positioning dowel.
- Design the jig so that no unreasonable mechanical stress is not applied to the semiconductor device.

f. Heat sink screw holes

- Be sure that chamfering and shear drop of heat sinks must not be larger than the diameter of screw head used.
- When using nuts, do not make the heat sink hole diameters larger than the diameter of the head of the screws used. A hole diameter about 15% larger than the diameter of the screw is desirable.
- When tap screws are used, be sure that the diameter of the holes in the heat sink are not too small. A diameter about 15% smaller than the diameter of the screw is desirable.

- g. There is a method to mount the semiconductor device to the heat sink by using a spring band. But this method is not recommended because of possible displacement due to fluctuation of the spring force with time or vibration.

LV5683P

ORDERING INFORMATION

Device	Package	Shipping (Qty / Packing)
LV5683P-E	HZIP15 (Pb-Free)	20 / Fan-Fold

ON Semiconductor and the ON logo are registered trademarks of Semiconductor Components Industries, LLC (SCILLC). SCILLC owns the rights to a number of patents, trademarks, copyrights, trade secrets, and other intellectual property. A listing of SCILLC's product/patent coverage may be accessed at www.onsemi.com/site/pdf/Patent-Marking.pdf. SCILLC reserves the right to make changes without further notice to any products herein. SCILLC makes no warranty, representation or guarantee regarding the suitability of its products for any particular purpose, nor does SCILLC assume any liability arising out of the application or use of any product or circuit, and specifically disclaims any and all liability, including without limitation special, consequential or incidental damages. "Typical" parameters which may be provided in SCILLC data sheets and/or specifications can and do vary in different applications and actual performance may vary over time. All operating parameters, including "Typicals" must be validated for each customer application by customer's technical experts. SCILLC does not convey any license under its patent rights nor the rights of others. SCILLC products are not designed, intended, or authorized for use as components in systems intended for surgical implant into the body, or other applications intended to support or sustain life, or for any other application in which the failure of the SCILLC product could create a situation where personal injury or death may occur. Should Buyer purchase or use SCILLC products for any such unintended or unauthorized application, Buyer shall indemnify and hold SCILLC and its officers, employees, subsidiaries, affiliates, and distributors harmless against all claims, costs, damages, and expenses, and reasonable attorney fees arising out of, directly or indirectly, any claim of personal injury or death associated with such unintended or unauthorized use, even if such claim alleges that SCILLC was negligent regarding the design or manufacture of the part. SCILLC is an Equal Opportunity/Affirmative Action Employer. This literature is subject to all applicable copyright laws and is not for resale in any manner.

X-ON Electronics

Largest Supplier of Electrical and Electronic Components

Click to view similar products for [Power Management IC Development Tools](#) *category:*

Click to view products by [ON Semiconductor](#) *manufacturer:*

Other Similar products are found below :

[EVAL-ADM1168LQEBZ](#) [EVB-EP5348UI](#) [MIC23451-AAAYFL EV](#) [MIC5281YMME EV](#) [DA9063-EVAL](#) [ADP122-3.3-EVALZ](#) [ADP130-0.8-EVALZ](#) [ADP130-1.2-EVALZ](#) [ADP130-1.5-EVALZ](#) [ADP130-1.8-EVALZ](#) [ADP1712-3.3-EVALZ](#) [ADP1714-3.3-EVALZ](#) [ADP1715-3.3-EVALZ](#) [ADP1716-2.5-EVALZ](#) [ADP1740-1.5-EVALZ](#) [ADP1752-1.5-EVALZ](#) [ADP1828LC-EVALZ](#) [ADP1870-0.3-EVALZ](#) [ADP1871-0.6-EVALZ](#) [ADP1873-0.6-EVALZ](#) [ADP1874-0.3-EVALZ](#) [ADP1882-1.0-EVALZ](#) [ADP199CB-EVALZ](#) [ADP2102-1.25-EVALZ](#) [ADP2102-1.875EVALZ](#) [ADP2102-1.8-EVALZ](#) [ADP2102-2-EVALZ](#) [ADP2102-3-EVALZ](#) [ADP2102-4-EVALZ](#) [ADP2106-1.8-EVALZ](#) [ADP2147CB-110EVALZ](#) [AS3606-DB](#) [BQ24010EVM](#) [BQ24075TEVM](#) [BQ24155EVM](#) [BQ24157EVM-697](#) [BQ24160EVM-742](#) [BQ24296MEVM-655](#) [BQ25010EVM](#) [BQ3055EVM](#) [NCV891330PD50GEVB](#) [ISLUSBI2CKIT1Z](#) [LM2744EVAL](#) [LM2854EVAL](#) [LM3658SD-AEV/NOPB](#) [LM3658SDEV/NOPB](#) [LM3691TL-1.8EV/NOPB](#) [LM4510SDEV/NOPB](#) [LM5033SD-EVAL](#) [LP38512TS-1.8EV](#)