



ON Semiconductor®

<http://onsemi.com>

# LV5684NPVD

Bi-CMOS IC

## System Power Supply IC for Automotive Infotainment Multiple Output Linear Voltage Regulator

### Overview

The LV5684NPVD is a multiple output linear regulator IC, which allows reduction of quiescent current. The LV5684NPVD is specifically designed to address automotive infotainment systems power supply requirements. The LV5684NPVD integrates 5 linear regulator outputs, 2 high side power switches, over-current limiter, overvoltage protection and thermal shut down. Supply for VDD and SW33V outputs is low voltage specification, which enables drastic reduction of power dissipation compared to the existing model.

### Function

- Low consumption current: 50 $\mu$ A (typ, only VDD output is in operation)
- 5 systems of regulator output
  - VDD for microcontroller: output voltage: 3.3V,  
maximum output current: 350mA .
  - For system: output voltage: 3.3V, maximum output current: 450mA
  - For audio: output voltage: 5 to 12V (set by external resistors),  
maximum output current: 250mA
  - For illumination: output voltage: 5 to 12V (set by external resistors),  
maximum output current: 300mA
  - For CD: output voltage: 5V/8V, maximum output current: 1300mA
- 2 lines of high side switch with current protection
  - EXT: Maximum output current: 350mA,  
voltage difference between input and output: 0.5V
  - ANT: Maximum output current: 300mA,  
voltage difference between input and output: 0.5V
- Supply input
  - V6IN: 6V for VDD, system (SW33V)
  - VCC1: For internal reference voltage, control circuits  
In case of voltage drop of V6IN, VCC1 supplies to VDD output.
  - VCC2: For AUDIO, illumination, CD, EXT/ANT
- Over-current limiter
- Overvoltage protector(OVP): VCC1, VCC2 Typ 23V (All outputs except VDD are turned off)  
Overvoltage shutdown(OVS): V6IN Typ 23V (All outputs except VDD are turned off)
- Thermal shut down : Typ 175°C

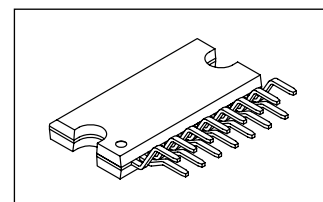

HZIP15

(Warning) The protector functions only improve the IC's tolerance and they do not guarantee the safety of the IC if used under the conditions out of safety range or ratings. Use of the IC such as use under overcurrent protection range, thermal shutdown state or V6IN OVS condition may degrade the IC's reliability and eventually damage the IC.

### ORDERING INFORMATION

See detailed ordering and shipping information on page 15 of this data sheet.

# LV5684NPVD

## Specifications

### Absolute Maximum Ratings at $T_a = 25^\circ\text{C}$

Parameter	Symbol	Conditions	Ratings	Unit	
Supply voltage	$V_{CC}$ max	$V_{CC1}, V_{CC2}$	36	V	
	$V_{6IN}$ max	$V_{6IN}$ (*)	7	V	
Input voltage	$V_{IN}$ max	CTRL1, CTRL2	7	V	
Allowable power dissipation	$P_d$ max	Independent IC	$T_a \leq 25^\circ\text{C}$	1.3	W
		Al heat sink *		5.3	W
		With an infinity heat sink		26	W
Peak supply voltage	$V_{CC}$ peak	See below for the waveform applied.	50	V	
Operating ambient temperature	$T_{opr}$		-40 to +85	$^\circ\text{C}$	
Storage temperature	$T_{stg}$		-55 to +150	$^\circ\text{C}$	
Junction temperature	$T_j$ max		150	$^\circ\text{C}$	

\* : When the Aluminum heat sink (50mm × 50mm × 1.5mm) is used

Caution 1) Absolute maximum ratings represent the value which cannot be exceeded for any length of time.

Caution 2) Even when the device is used within the range of absolute maximum ratings, as a result of continuous usage under high temperature, high current, high voltage, or drastic temperature change, the reliability of the IC may be degraded. Please contact us for the further details.

### Waveform of surge test ( $V_{CC1}, V_{CC2}$ )

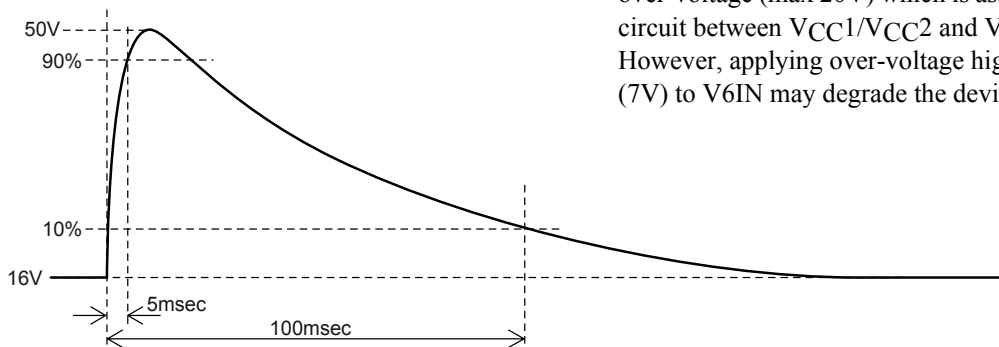

\* $V_{6IN}$  is designed to tolerant toward short period of over-voltage (max 20V) which is assumed in condition of short circuit between  $V_{CC1}/V_{CC2}$  and  $V_{6IN}$ . However, applying over-voltage higher than maximum rating (7V) to  $V_{6IN}$  may degrade the device reliability

Stresses exceeding those listed in the Maximum Ratings table may damage the device. If any of these limits are exceeded, device functionality should not be assumed, damage may occur and reliability may be affected.

### Recommended Operating Conditions at $T_a = 25^\circ\text{C}$

#### $V_{CC1}$

Parameter	Conditions	Ratings	Unit
Operating supply voltage 1	$V_{DD}$ output	7 to 16	V

#### $V_{CC2}$

Parameter	Conditions	Ratings	Unit
Operating supply voltage 2	ILM output (10V)	12 to 16	V
	ILM output (8V)	10 to 16	V
Operating supply voltage 3	AUDIO output (9V)	10 to 16	V
Operating supply voltage 4	CD output ( $I_O = 1.3\text{A}$ )	10.5 to 16	V
	CD output ( $I_O \leq 1\text{A}$ )	10 to 16	V
Operating supply voltage 5	EXT output, ANT output	10 to 16	V

#### $V_{6IN}$

Parameter	Conditions	Ratings	Unit
Operating supply voltage 6	$V_{DD}$ output, SW33V output	5.7 to 6.5	V

Functional operation above the stresses listed in the Recommended Operating Ranges is not implied. Extended exposure to stresses beyond the Recommended Operating Ranges limits may affect device reliability.

# LV5684NPVD

## Electrical Characteristics at $V_{CC1} = V_{CC2} = 14.4V$ , $V_{6IN} = 6V$ at $T_a = 25^\circ C$ (\*1)

Parameter	Symbol	Conditions	Ratings			Unit
			min	typ	max	
Quiescent current	$I_{CC}$	$V_{DD}$ w/out load, CTRL1/2 = "L/L"		50	100	$\mu A$
<b>CTRL1 input (ANT/EXT/ILM)</b>						
Low input voltage	$V_{IL1}$		0		0.5	V
M1 input voltage	$V_{IM1}$		0.8	1.1	1.4	V
M2 input voltage	$V_{IM2}$		1.9	2.2	2.5	V
High input voltage	$V_{IH1}$		2.9	3.3	5.5	V
Input impedance	$R_{IH1}$	input voltage $\leq 3.3V$	280	400	480	$k\Omega$
<b>CTRL2 input (CD/AUDIO/SW33V)</b>						
Low input voltage	$V_{IL2}$		0		0.5	V
M1 input voltage	$V_{IM2}$		0.8	1.1	1.4	V
M2 input voltage	$V_{IM2}$		1.9	2.2	2.5	V
High input voltage	$V_{IH2}$		2.9	3.3	5.5	V
Input impedance	$R_{IH2}$	input voltage $\leq 3.3V$	280	400	480	$k\Omega$
<b><math>V_{DD}</math> output (3.3V)</b>						
Output voltage	$V_{O1}$	$I_{O1} = 200mA$	3.13	3.3	3.47	V
Output current	$I_{O1}$	$V_{O1} \geq 3.1V$	350			mA
Line regulation	$\Delta V_{OLN1}$	$5.7V < V_{6IN} < 6.5V$ , $I_{O1} = 200mA$ or $V_{6IN} = 0V$ , $7.5V < V_{CC1} < 16V$ , $I_{O1} = 200mA$		30	90	mV
Load regulation	$\Delta V_{OLD1}$	$1mA < I_{O1} < 200mA$		70	150	mV
Dropout voltage	$V_{DROP1}$	$I_{O1} = 200mA$ , $V_{6IN} = 0V$ (applicable to $V_{CC1}$ )		1.9	2.8	V
Ripple rejection (*2)	$R_{REJ1}$	$f = 120Hz$ , $V_{6IN}$ or $V_{CC1} = 0.5V_{pp}$ $I_{O1} = 200mA$	40	50		dB
<b>SW33V output (3.3V) ; CTRL2 = "M1 or M2 or H"</b>						
Output voltage	$V_{O2}$	$I_{O2} = 200mA$	3.13	3.3	3.47	V
Output current	$I_{O2}$	$V_{O2} \geq 3.1V$	450			mA
Line regulation	$\Delta V_{OLN2}$	$5.7V < V_{6IN} < 6.5V$ , $I_{O2} = 200mA$		30	90	mV
Load regulation	$\Delta V_{OLD2}$	$1mA < I_{O2} < 200mA$		70	150	mV
Dropout voltage	$V_{DROP2}$	$I_{O2} = 200mA$		0.25	0.5	V
Ripple rejection (*2)	$R_{REJ2}$	$f = 120Hz$ , $V_{6IN}$ or $V_{CC1} = 0.5V_{pp}$ $I_{O2} = 200mA$	40	50		dB
<b>AUDIO (5-12V)output ; CTRL2 = "M1 or M2 or H"</b>						
AUDIO_F voltage	$V_{I3}$		1.212	1.25	1.288	V
AUDIO_F input current	$I_{IN3}$		-1		1	$\mu A$
AUDIO output voltage 1	$V_{O3}$	$I_{O3} = 200mA$ , $R1 = 43k\Omega$ , $R2 = 5.1k\Omega$ (*3)	11.21	11.8	12.39	V
AUDIO output voltage 2	$V_{O3'}$	$I_{O3} = 150mA$ , $R3 = 27k\Omega$ , $R4 = 4.7k\Omega$ (*3)	8.13	8.5	8.87	V
AUDIO output voltage 3	$V_{O3''}$	$I_{O3} = 150mA$ , $R3 = 30k\Omega$ , $R4 = 10k\Omega$ (*3)	4.75	5.0	5.25	V
AUDIO output current	$I_{O3}$		250			mA
Line regulation	$\Delta V_{OLN3}$	$10V < V_{CC2} < 16V$ , $I_{O3} = 150mA$		30	90	mV
Load regulation	$\Delta V_{OLD3}$	$1mA < I_{O3} < 150mA$		70	150	mV
Dropout voltage 1	$V_{DROP3}$	$I_{O3} = 150mA$		0.3	0.45	V
Ripple rejection (*2)	$R_{REJ3}$	$f = 120Hz$ , $I_{O3} = 150mA$	40	50		dB
<b>ILM (5-12V) output ; CTRL1 = "M1 or M2 or H"</b>						
ILM_F voltage	$V_{I4}$		1.212	1.25	1.288	V
ILM_F input current	$I_{IN4}$		-1		1	$\mu A$
ILM output voltage 1	$V_{O4}$	$I_{O4} = 200mA$ , $R1 = 43k\Omega$ , $R2 = 5.1k\Omega$ (*3)	11.21	11.8	12.39	V
ILM output voltage 2	$V_{O4'}$	$I_{O4} = 200mA$ , $R1 = 56k\Omega$ , $R2 = 7.5k\Omega$ (*3)	9.97	10.5	11.03	V
ILM output voltage 3	$V_{O4''}$	$I_{O4} = 200mA$ , $R1 = 30k\Omega$ , $R2 = 5.6k\Omega$ (*3)	7.6	8.0	8.4	V
ILM output voltage 4	$V_{O4'''}$	$I_{O4} = 200mA$ , $R1 = 30k\Omega$ , $R2 = 10k\Omega$ (*3)	4.75	5.0	5.25	V
ILM output current	$I_{O4}$		300			mA

Continued on next page.

# LV5684NPVD

Continued from preceding page.

Parameter	Symbol	Conditions	Ratings			Unit
			min	typ	max	
Line regulation	$\Delta V_{OLN4}$	$10V < V_{CC2} < 16V, I_{O4} = 200mA$ $R1 = 30k\Omega, R2 = 5.6k\Omega$		30	90	mV
Load regulation	$\Delta V_{OLD4}$	$1mA < I_{O4} < 200mA$		70	150	mV
Dropout voltage 1	$V_{DROP4}$	$I_{O4} = 200mA$		0.7	1.05	V
Dropout voltage 2	$V_{DROP4}'$	$I_{O4} = 100mA$		0.35	0.53	V
Ripple rejection (*2)	$R_{REJ4}$	$f = 120Hz, I_{O4} = 200mA$	40	50		dB
<b>CD (5V/8V output) ; CTRL2 = "H" : 8V, CTRL2 = "M2" : 5V</b>						
Output voltage	$V_{O51}$	$I_{O5} = 1000mA$	4.75	5.0	5.25	V
	$V_{O52}$	$I_{O5} = 1000mA$	7.6	8.0	8.4	V
Output current	$I_{O5}$	$V_{O51} \geq 4.7V, V_{O52} \geq 7.6V$	1300			mA
Line regulation	$\Delta V_{OLN5}$	$10.5V < V_{CC2} < 16V, I_{O5} = 1000mA$		50	100	mV
Load regulation	$\Delta V_{OLD5}$	$10mA < I_{O5} < 1000mA$		100	200	mV
Dropout voltage 1	$V_{DROP5}$	$I_{O5} = 1000mA$		1.0	1.5	V
Dropout voltage 2	$V_{DROP5}'$	$I_{O5} = 500mA$		0.5	0.75	V
Ripple rejection (*2)	$R_{REJ5}$	$f = 120Hz, I_{O5} = 1000mA$	40	50		dB
<b>EXT_HS-SW ; CTRL1 = "M2 or H"</b>						
Output voltage	$V_{O6}$	$I_{O6} = 350mA$	$V_{CC2-1.0}$	$V_{CC2-0.5}$		V
Output current	$I_{O6}$	$V_{O6} \geq V_{CC2-1.0}$	350			mA
<b>ANT_HS-SW ; CTRL1 = "H"</b>						
Output voltage	$V_{O7}$	$I_{O7} = 300mA$	$V_{CC2-1.0}$	$V_{CC2-0.5}$		V
Output current	$I_{O7}$	$V_{O7} \geq V_{CC2-1.0}$	300			mA

\*1 : All the specification is defined based on the tests performed under the conditions where  $T_j$  and  $T_a$  ( $= 25^\circ C$ ) are almost equal. These tests were performed with pulse load to minimize the increase of junction temperature ( $T_j$ ).

\*2 : guaranteed by design

\*3 : Using resistors of tolerance within 1%.

Product parametric performance is indicated in the Electrical Characteristics for the listed test conditions, unless otherwise noted. Product performance may not be indicated by the Electrical Characteristics if operated under different conditions.

# LV5684NPVD

## Package Dimensions

unit : mm

**HZIP15**  
CASE 945AB  
ISSUE A

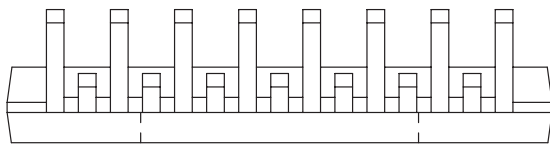
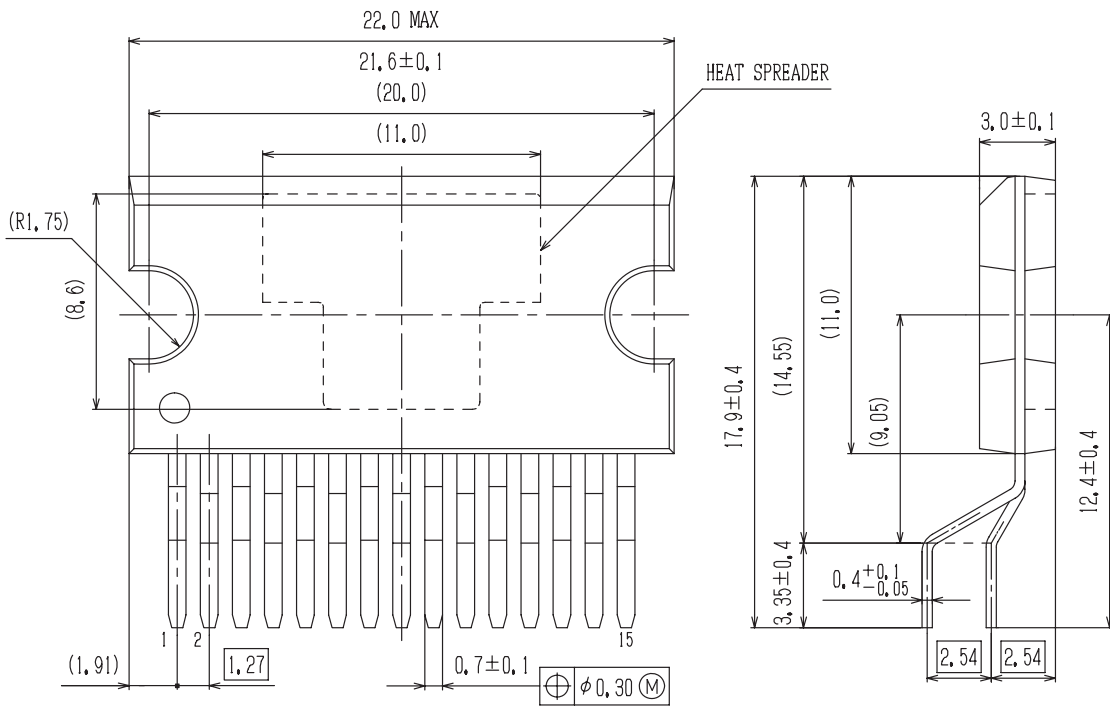

SOLDERING FOOTPRINT\*

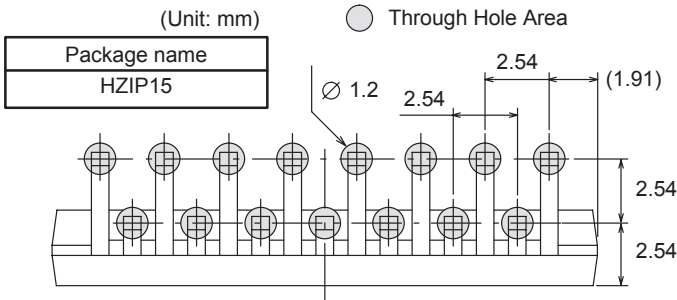

GENERIC MARKING DIAGRAM\*

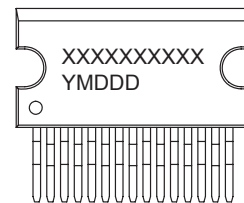

XXXXX = Specific Device Code  
Y = Year  
M = Month  
DDD = Additional Traceability Data

\*This information is generic. Please refer to device data sheet for actual part marking. Pb-Free indicator, "G" or microdot "▪", may or may not be present.

NOTE: The measurements are not to guarantee but for reference only.

\*For additional information on our Pb-Free strategy and soldering details, please download the ON Semiconductor Soldering and Mounting Techniques Reference Manual, SOLDERRM/D.

## CTRL logic truth table

CTRL1	ANT	EXT	ILM
H	ON	ON	ON
M2	OFF	ON	ON
M1	OFF	OFF	ON
L	OFF	OFF	OFF

CTRL2	CD	AUDIO	SW33V
H	ON (8V)	ON	ON
M2	ON (5V)	ON	ON
M1	OFF	ON	ON
L	OFF	OFF	OFF

## CTRL1/2 voltage range and threshold

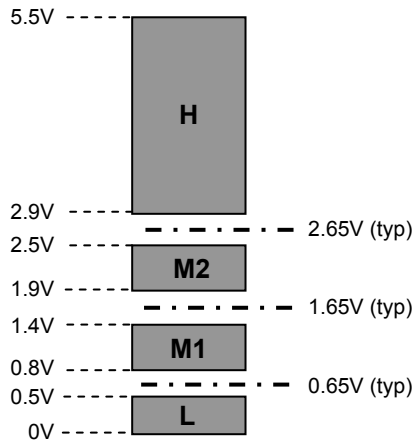

- Allowable power dissipation derating curve

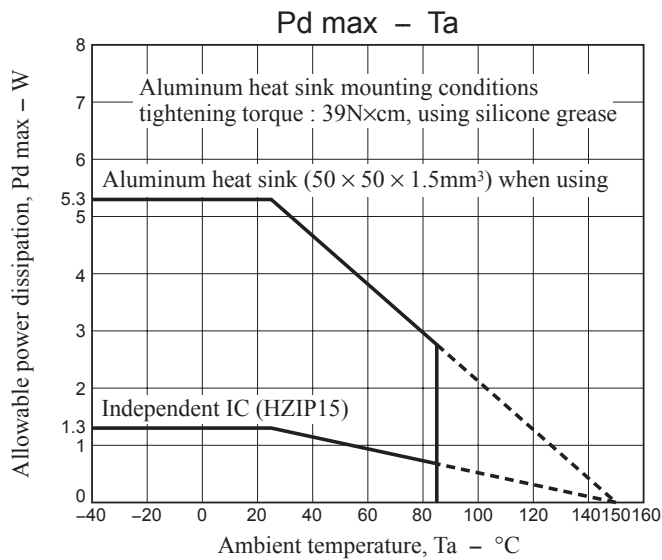

# LV5684NPVD

## Application Circuit Example

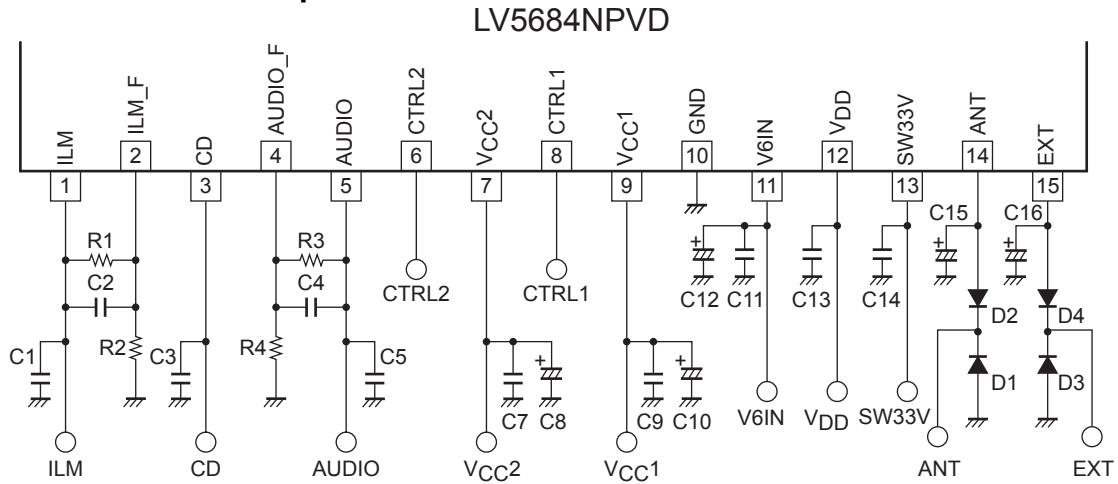

### Peripheral parts

Part name	Description	Recommended value	Note
C1, C3, C5, C13, C14	output stabilization capacitor	greater than 10 $\mu$ F (*1)	
C2, C4	output stabilization capacitor	0pF	Ceramic capacitor
C8, C10, C12	Capacitor for bypass power supply	C8: greater than 100 $\mu$ F C10, C12: greater than 47 $\mu$ F	Make sure to implement close to V <sub>CC</sub> and GND.
C7, C9, C11	Capacitor for oscillation protector	greater than 0.22 $\mu$ F	
C15, C16	Capacitor for EXT/ANT output stabilization	greater than 2.2 $\mu$ F	
R1, R2	ILM voltage setting	R1/R2 43k $\Omega$ /5.1k $\Omega$ : V <sub>O</sub> = 12V 56k $\Omega$ /7.5k $\Omega$ : V <sub>O</sub> = 10.5V 30k $\Omega$ /5.6k $\Omega$ : V <sub>O</sub> = 8V 30k $\Omega$ /10k $\Omega$ : V <sub>O</sub> = 5V	Use resistors of tolerance within 1%
R3, R4	AUDIO voltage setting	R3/R4 30k $\Omega$ /10k $\Omega$ : V <sub>O</sub> = 5V 27k $\Omega$ /4.7k $\Omega$ : V <sub>O</sub> = 8.5V 43k $\Omega$ /5.1k $\Omega$ : V <sub>O</sub> = 12V	Use resistors of tolerance within 1%
D1, D2, D3, D4	Internal device protector diode	ON Semiconductor SB1003M3	

(\*1) Make sure that output capacitors are greater than 10 $\mu$ F and meets the condition of ESR = 0.001 to 10 $\Omega$ , in which voltage/ temperature dependence and unit differences are taken into consideration. Moreover, in case of electrolytic capacitor, high-frequency characteristics should be sufficiently good.

# LV5684NPVD

## Block Diagram

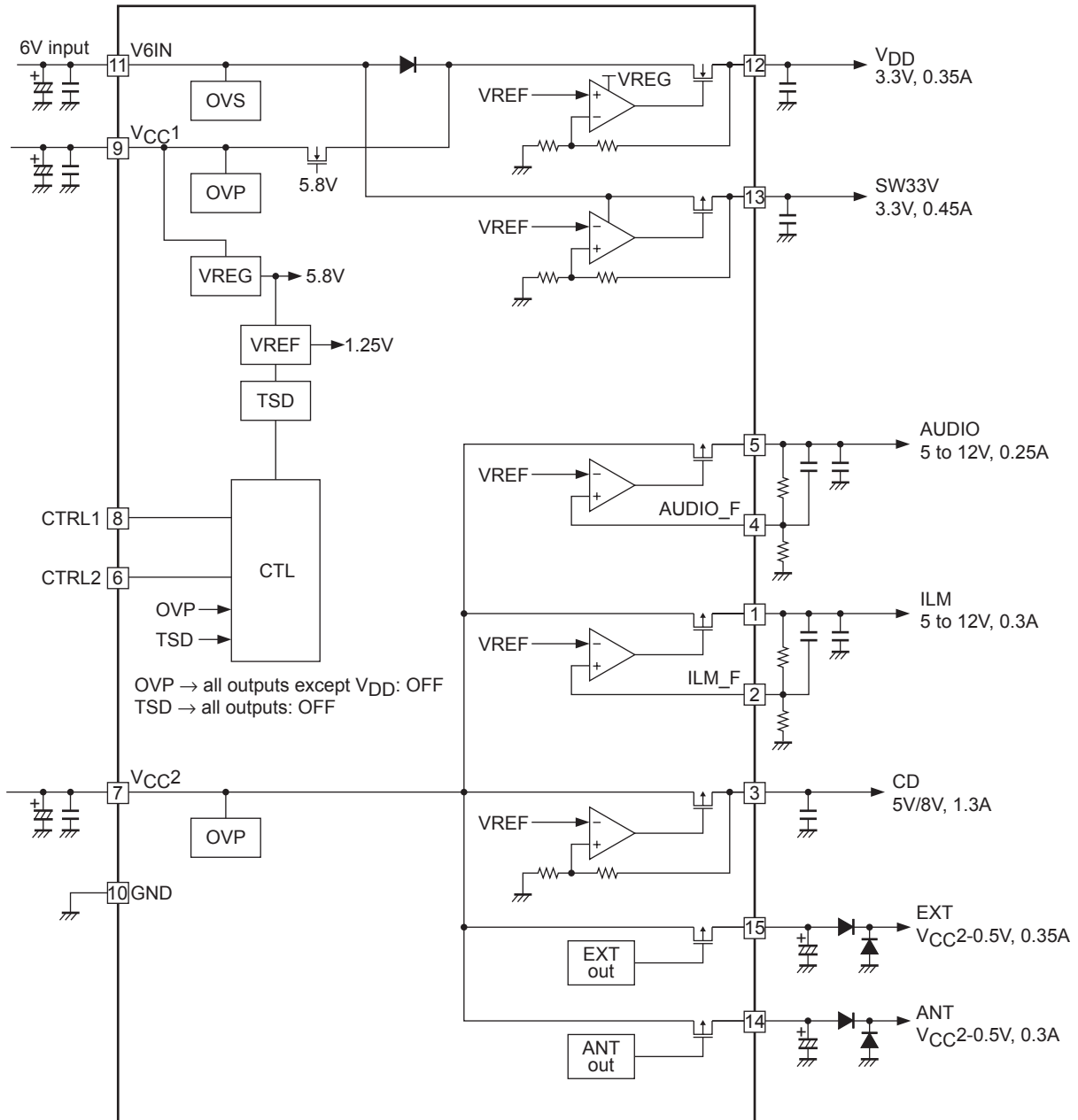

## Pin Function

Pin No.	Pin name	Description	Equivalent Circuit
1	ILM	ILM output When CTRL1 = M1, M2, H, ILM is ON	
2	ILM_F	ILM voltage adjust	

Continued on next page.



# LV5684NPVD

Continued from preceding page.

Pin No.	Pin name	Description	Equivalent Circuit
3	CD	CD output When CTRL2 = M2, H, CD is ON 5V or 8V/1.3A	
4	AUDIO_F	AUDIO voltage adjust	
5	AUDIO	AUDIO output When CTRL2 = M1, M2, H, AUDIO is ON	
6	CTRL2	CTRL2 input 4-value input	
7	VCC2	Power supply	
8	CTRL1	CTRL1 input 4-value input	
9	VCC1	Power supply	
10	GND	GND	
11	V6IN	Power supply	

Continued on next page.

# LV5684NPVD

Continued from preceding page.

Pin No.	Pin name	Description	Equivalent Circuit
12	V <sub>DD</sub>	V <sub>DD</sub> output 3.3V/0.35A	
13	SW33V	SW33V output When CTRL2 = M1, M2, H, SW33V is ON 3.3V/0.45A	
14	ANT	ANT output When CTRL1 = H, ANT is ON V <sub>CC</sub> -0.5V/300mA	
15	EXT	EXT output When CTRL1 = M2, H, EXT is ON V <sub>CC</sub> -0.5V/350mA	

## LV5684NPVD

### ■Note for VDD output(PIN12) and V6IN (PIN11)

This product doesn't have reverse current prevention feature for the path of VDD to VCC1. As shown above equivalent circuit for PIN12, there exists a parasitic diode from VDD to VCC1. Accordingly if VCC1 voltage drops below approximately  $VDD - 0.7V$ , reverse current flows from VDD to VCC1. If you need to prevent this current, insert a diode between VCC2 and VCC1 as shown on the figure below.

As the same manner, there is a parasitic diode from V6IN to VCC1.

Do not apply voltage to these terminals so that these parasitic diodes are positively biased.

Use under the following condition.

$$VCC \geq VDD, VCC1 \geq V6IN$$

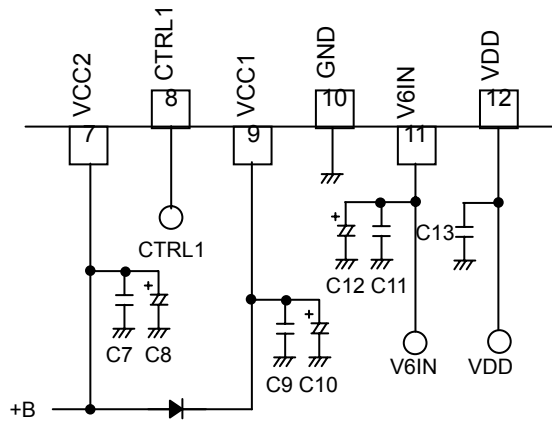

Timing Chart

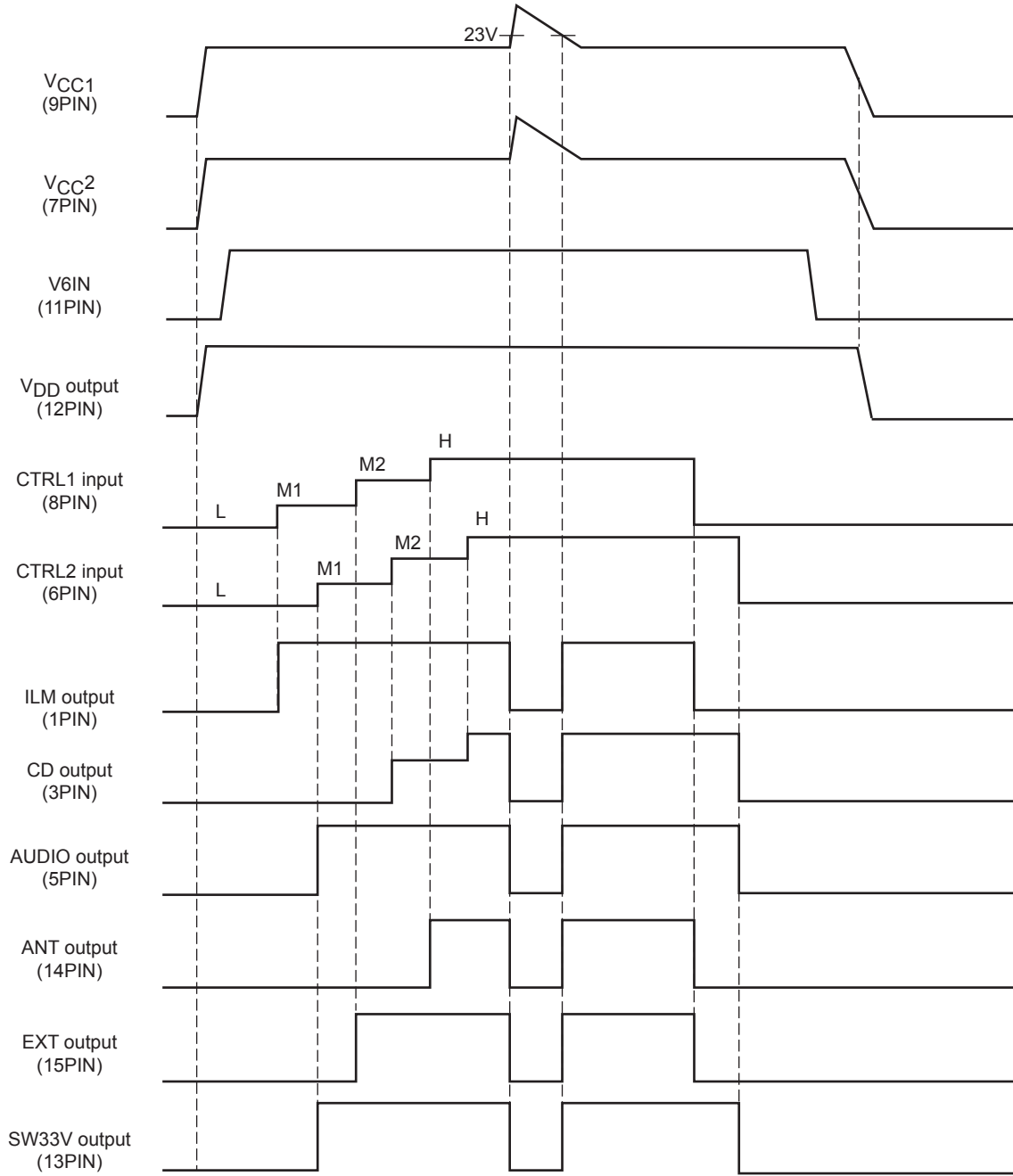

Caution: The above values are obtained when typ.

## LV5684NPVD

- How to set AUDIO output voltage

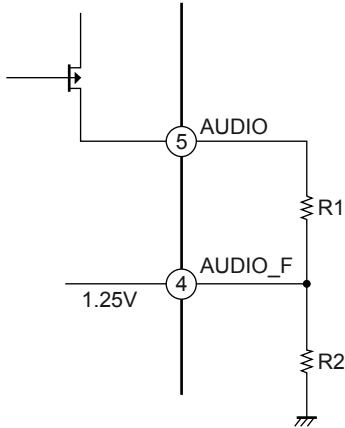

AUDIO\_F is determined by internal band-gap reference voltage (typ = 1.25V).

AUDIO output voltage expression

$$AUDIO = \left(\frac{R_1}{R_2} + 1\right) \times 1.25[V]$$

$$\frac{R_1}{R_2} = \frac{AUDIO}{1.25} - 1$$

Set the ratio of R1 and R2 to satisfy above expression.

(ex) AUDIO = 9V setting

$$\frac{R_1}{R_2} = \frac{9}{1.25} - 1 = 6.2$$

$$\frac{R_1}{R_2} = \frac{24k\Omega}{3.9k\Omega} \cong 6.15$$

$$AUDIO = (6.15 + 1) \times 1.25V \cong \boxed{8.94V}$$

- ILM output voltage is similarly calculated as AUDIO output.

(ex) ILM = 10.5V setting

$$\frac{R_1}{R_2} = \frac{10.5}{1.25} - 1 = 7.4$$

$$\frac{R_1}{R_2} = \frac{56k\Omega}{7.5k\Omega} \cong 7.46$$

$$ILM = (7.46 + 1) \times 1.25V \cong \boxed{10.575V}$$

Note : The above values are typical values. These values have variation among the range of their tolerances.

## HZIP15 Heat sink attachment

Heat sinks are used to lower the semiconductor device junction temperature by leading the heat generated by the device to the outer environment and dissipating that heat.

- a. Unless otherwise specified, for power ICs with tabs and power ICs with attached heat sinks, solder must not be applied to the heat sink or tabs.

b. Heat sink attachment

- Use flat-head screws to attach heat sinks.
- Use also washer to protect the package.
- Use tightening torques in the ranges 39-59Ncm (4-6kgcm) .
- If tapping screws are used, do not use screws with a diameter larger than the holes in the semiconductor device itself.
- Do not make gap, dust, or other contaminants to get between the semiconductor device and the tab or heat sink.
- Take care a position of via hole .
- Do not allow dirt, dust, or other contaminants to get between the semiconductor device and the tab or heat sink.
- Verify that there are no press burrs or screw-hole burrs on the heat sink.
- Warping in heat sinks and printed circuit boards must be no more than 0.05 mm between screw holes, for either concave or convex warping.
- Twisting must be limited to under 0.05 mm.
- Heat sink and semiconductor device are mounted in parallel.  
Take care of electric or compressed air drivers
- The speed of these torque wrenches should never exceed 700 rpm, and should typically be about 400 rpm.

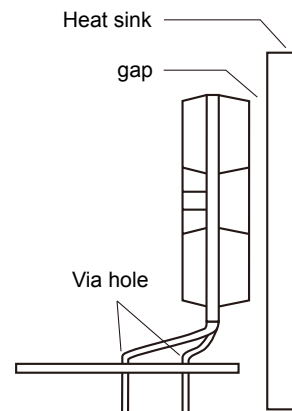
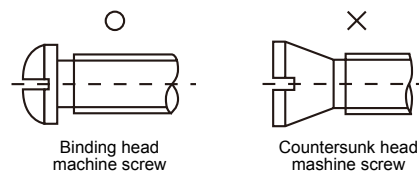

c. Silicone grease

- Spread the silicone grease evenly when mounting heat sinks.
- Recommends YG-6260 (Momentive Performance Materials Japan LLC)

d. Mount

- First mount the heat sink on the semiconductor device, and then mount that assembly on the printed circuit board.
- When attaching a heat sink after mounting a semiconductor device into the printed circuit board, when tightening up a heat sink with the screw, the mechanical stress which is impossible to the semiconductor device and the pin doesn't hang.

e. When mounting the semiconductor device to the heat sink using jigs, etc.,

- Take care not to allow the device to ride onto the jig or positioning dowel.
- Design the jig so that no unreasonable mechanical stress is applied to the semiconductor device.

f. Heat sink screw holes

- Be sure that chamfering and shear drop of heat sinks must not be larger than the diameter of screw head used.
- When using nuts, do not make the heat sink hole diameters larger than the diameter of the head of the screws used. A hole diameter about 15% larger than the diameter of the screw is desirable.
- When tap screws are used, be sure that the diameter of the holes in the heat sink are not too small. A diameter about 15% smaller than the diameter of the screw is desirable.

- g. There is a method to mount the semiconductor device to the heat sink by using a spring band. But this method is not recommended because of possible displacement due to fluctuation of the spring force with time or vibration.

# LV5684NPVD

---

## ORDERING INFORMATION

Device	Package	Shipping (Qty / Packing)
LV5684NPVD-XH	HZIP15 (Pb-Free / Halogen Free)	20 / Fan-Fold

ON Semiconductor and the ON logo are registered trademarks of Semiconductor Components Industries, LLC (SCILLC). SCILLC owns the rights to a number of patents, trademarks, copyrights, trade secrets, and other intellectual property. A listing of SCILLC's product/patent coverage may be accessed at [www.onsemi.com/site/pdf/Patent-Marking.pdf](http://www.onsemi.com/site/pdf/Patent-Marking.pdf). SCILLC reserves the right to make changes without further notice to any products herein. SCILLC makes no warranty, representation or guarantee regarding the suitability of its products for any particular purpose, nor does SCILLC assume any liability arising out of the application or use of any product or circuit, and specifically disclaims any and all liability, including without limitation special, consequential or incidental damages. "Typical" parameters which may be provided in SCILLC data sheets and/or specifications can and do vary in different applications and actual performance may vary over time. All operating parameters, including "Typicals" must be validated for each customer application by customer's technical experts. SCILLC does not convey any license under its patent rights nor the rights of others. SCILLC products are not designed, intended, or authorized for use as components in systems intended for surgical implant into the body, or other applications intended to support or sustain life, or for any other application in which the failure of the SCILLC product could create a situation where personal injury or death may occur. Should Buyer purchase or use SCILLC products for any such unintended or unauthorized application, Buyer shall indemnify and hold SCILLC and its officers, employees, subsidiaries, affiliates, and distributors harmless against all claims, costs, damages, and expenses, and reasonable attorney fees arising out of, directly or indirectly, any claim of personal injury or death associated with such unintended or unauthorized use, even if such claim alleges that SCILLC was negligent regarding the design or manufacture of the part. SCILLC is an Equal Opportunity/Affirmative Action Employer. This literature is subject to all applicable copyright laws and is not for resale in any manner.

## X-ON Electronics

Largest Supplier of Electrical and Electronic Components

*Click to view similar products for* [Power Management Specialised - PMIC category:](#)

*Click to view products by* [ON Semiconductor manufacturer:](#)

Other Similar products are found below :

[LV5686PVC-XH](#) [FAN7710VN](#) [NCP391FCALT2G](#) [SLG7NT4081VTR](#) [SLG7NT4192VTR](#) [AP4313UKTR-G1](#) [AS3729B-BWLM](#)  
[MB39C831QN-G-EFE2](#) [MAX4940MB](#) [LV56841PVD-XH](#) [MAX77686EWE+T](#) [AP4306BUKTR-G1](#) [MIC5164YMM](#) [PT8A3252WE](#)  
[NCP392CSFCCT1G](#) [TEA1998TS/1H](#) [PT8A3284WE](#) [PI3VST01ZEEX](#) [PI5USB1458AZAEX](#) [PI5USB1468AZAEX](#) [MCP16502TAC-E/S8B](#)  
[MCP16502TAE-E/S8B](#) [MCP16502TAA-E/S8B](#) [MCP16502TAB-E/S8B](#) [TCKE712BNL,RF](#) [ISL91211AIKZT7AR5874](#)  
[ISL91211BIKZT7AR5878](#) [MAX17506EVKITBE#](#) [MCP16501TC-E/RMB](#) [ISL91212AIIZ-TR5770](#) [ISL91212BIIZ-TR5775](#) [CPX200D](#) [AX-](#)  
[3005D-3](#) [TP-1303](#) [TP-1305](#) [TP-1603](#) [TP-2305](#) [TP-30102](#) [TP-4503N](#) [MIC5167YML-TR](#) [LPTM21-1AFTG237C](#) [MPS-3003L-3](#) [MPS-3005D](#)  
[SPD-3606](#) [STLUX383A](#) [TP-60052](#) [ADN8834ACBZ-R7](#) [LM26480SQ-AA/NOPB](#) [LM81BIMTX-3/NOPB](#) [LM81CIMT-3/NOPB](#)