



ON Semiconductor®

<http://onsemi.com>

LV8080LP

Bi-CMOS LSI

Two channels Constant-current H-bridge Driver

Overview

The LV8080LP is a two-channel constant-current driver that supports low-voltage operation. It is optimal for constant-current drive of stepping motors (AF and zoom) in portable equipment such as camera cell phones.

Features

- Two channels constant-current H-bridge driver
- Built-in power supply switch and position detection comparator for use with a photoreflector
- Supports both 2-phase drive and 1-2 phase drive.
- Implemented in a low-power MOS IC process.
- Ultraminiature easy to solder VCT16 package (2.6 × 2.6mm)
- Built-in thermal protection and low-voltage sensing circuits

Specifications

Absolute Maximum Ratings at $T_a = 25^\circ\text{C}$

Parameter	Symbol	Conditions	Ratings	Unit
Maximum supply voltage	V_{CC} , VM max		6.5	V
Output voltage	V_{OUT} max	OUT1, OUT2, OUT3, OUT4	6.5	V
Input voltage	V_{IN} max	CONT, IN	-0.3 to +6.5	V
Ground pin source current	IGND	Per channel	400	mA
Allowable power dissipation	P_d max	Mounted on a circuit board.*	700	mW
Operating temperature	Topr		-30 to +85	°C
Storage temperature	Tstg		-40 to +150	°C

* Specified circuit board : 40×50×0.8mm³ : 4-layer (2S2P) glass epoxy printed circuit board

Stresses exceeding Maximum Ratings may damage the device. Maximum Ratings are stress ratings only. Functional operation above the Recommended Operating Conditions is not implied. Extended exposure to stresses above the Recommended Operating Conditions may affect device reliability.

LV8080LP

Allowable Operating Ratings at $T_a = 25^\circ\text{C}$

Parameter	Symbol	Conditions	Ratings	Unit
Supply voltage	V_{CC}		2.5 to 6.0	V
High-level input voltage	V_{IH}	CONT, IN	$0.6V_{CC}$ or more	V
Low-level input voltage	V_{IL}		Up to $0.2V_{CC}$	V

Electrical Characteristics at $T_a = 25^\circ\text{C}$, $V_{CC} = 3.0\text{V}$

Parameter	Symbol	Conditions	Ratings			Unit
			min	typ	max	
Current drain	I_{CCO}	EN = 0V		0.1	1	μA
	I_{CCO1}	EN = 3V		0.7	1	mA
Output on resistance	Ron1	$V_{CC} = 3.0\text{V}$ (High and low side total) EN = 3.0V, $I_{OUT} = 100\text{mA}$		2.0	3.0	Ω
	Ron2	$V_{CC} = 5.0\text{V}$ (High and low side total) EN = 5.0V, $I_{OUT} = 100\text{mA}$		1.50	2.0	Ω
Constant-current output 1	I_{OUT1}	Between RFG and ground : 1Ω	95	100	105	mA
Constant-current output 2	I_{OUT2}	Between RFG and ground : 0.5Ω (Design specification)	190	200	210	mA
Output turn-on time	Traise	With RFG1 and RFG2 shorted to ground (Design specification)		1.3	3	μs
Output turn-off time	Tfall	With RFG1 and RFG2 shorted to ground (Design specification)		0.25	0.65	μs
Position detection voltage (high level)	V_H			1.0	1.06	V
Position detection voltage (low level)	V_L		0.74	0.8		V
Detection voltage hysteresis	HYS		0.165	0.18	0.195	V
PI/PR pin current	$I_{PI/PR}$				20	mA
Input current	I_{IN}	$V_{IN} = 3\text{V}$		15	30	μA

Note : The design specification items are design guarantees and are not measured.

Package Dimensions

unit : mm (typ)

3318

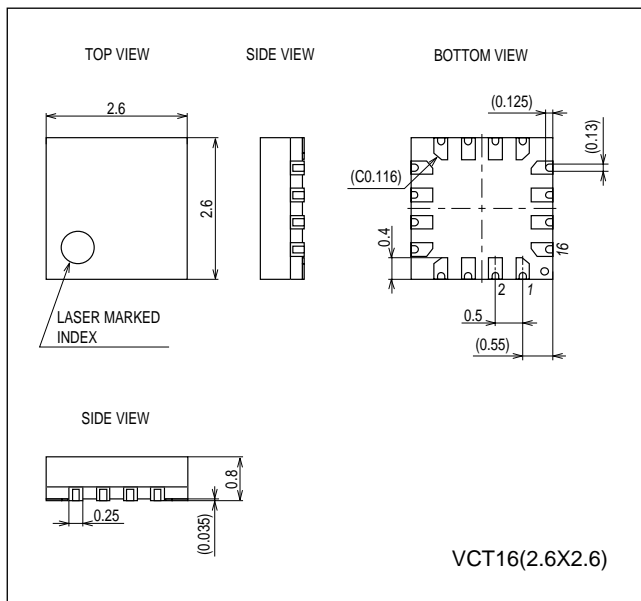

Pin Assignment

(VCT16)

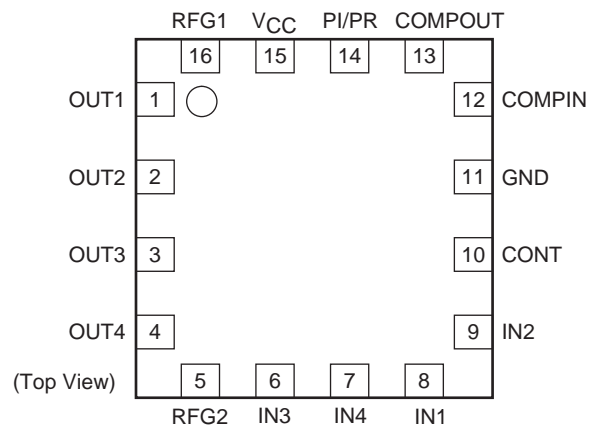

Block Diagram

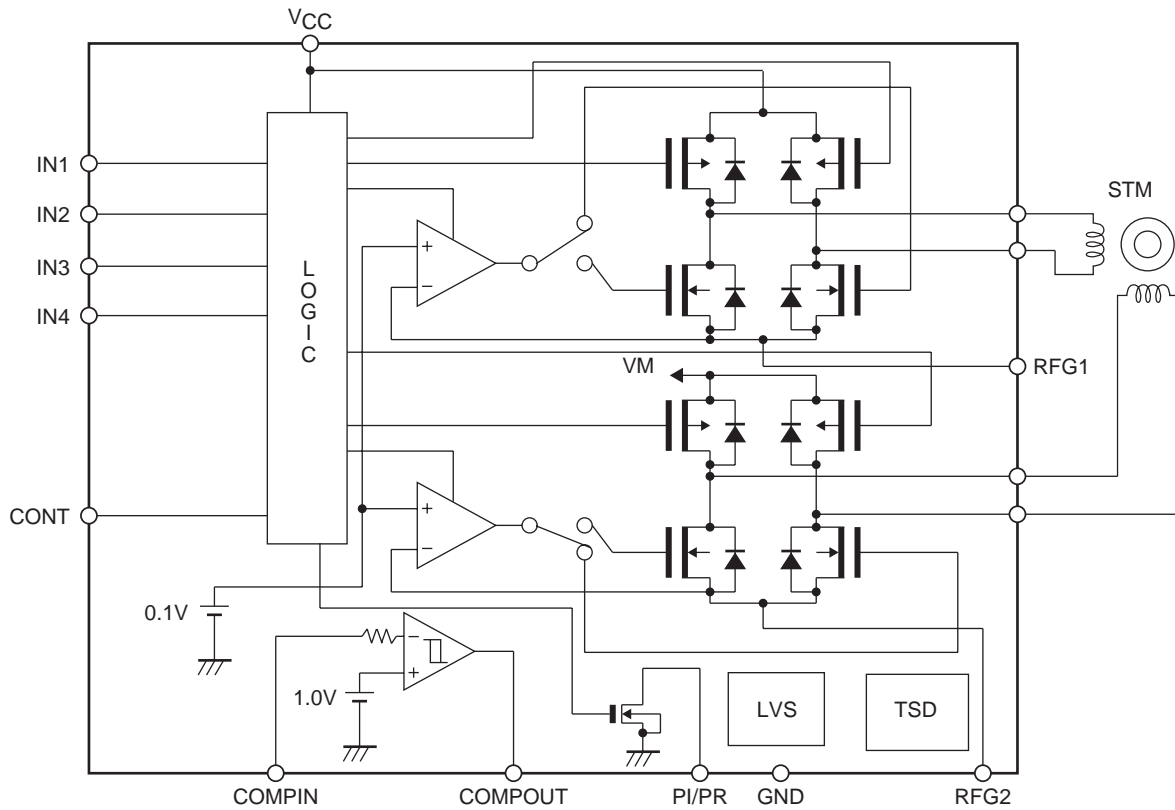

Constant-current calculation : $I_{OUT} = 0.1 \div R_F$ Example : When an I_{OUT} of 100mA is required, R_F must be 1Ω .

Usage Notes

The constant current is set by the resource R_F connected between RFG and ground according to the formula shown above.

Truth Table

Input				Output				Mode
IN1	IN2	IN3	IN4	OUT1	OUT2	OUT3	OUT4	
Low	Low	Low	Low	Off	Off	Off	Off	Standby mode
Low	High	-	-	Low	High	Off	Off	Channel 1, reverse
High	Low			High	Low			Channel 1, forward
High	High			Low	Low			Channel 1, brake mode
-	-	Low	High	Off	Off	Low	High	Channel 2, reverse
		High	Low			High	Low	Channel 2, forward
		High	High			Low	Low	Channel 2, brake mode

Note : The "-" input unstable state. When off, a high-impedance state.

- The ENA goes to the standby state with a low-level input, and to the operating state with a high-level input.
- The control input switches the forward/reverse mode.

LV8080LP

Pin Description

Pin No.	Pin Name	Description	Equivalent Circuit
1 2 3 4	OUT1 OUT2 OUT3 OUT4	1-4 : Output pins H-bridge type output pins Pins 1 and 2 are paired and pins 3 and 4 are paired.	
5 16	RFG2 RFG1	5, 16 : Current sensing resistor connection pins Connect the current sensing resistor between these pins and ground to detect the output currents for constant current control. Pin 16 corresponds to the output from pins 1 and 2 and pin 5 to the output from pins 1 and 2.	
6 7 8 9 10	IN3 IN4 IN1 IN2 CONT	Logic input pins	
11	GND	Ground	
12	COMPIN	Photo reflector position sensing comparator input	
13	COMPOUT	Photo reflector position sensing comparator output This pin serves as an open-collector output of the NPN transistor.	

Continued on next page.

LV8080LP

Continued from preceding page.

Pin No.	Pin Name	Description	Equivalent Circuit
14	PI/PR	<p>A switch, with NMOS open-drain output, used to turn on/off the power supply of the position sensor unit. When using this switch, connect the position sensor unit between this pin and the V_{CC} pin.</p> <p>On/off control of this switch is accomplished by CONT pin. Setting the CONT pin high turns on the switch.</p>	
15	V _{CC}	Power supply pin	

Timing Chart

(1) Stepper motor timing chart

Timing chart for 2-phase drive

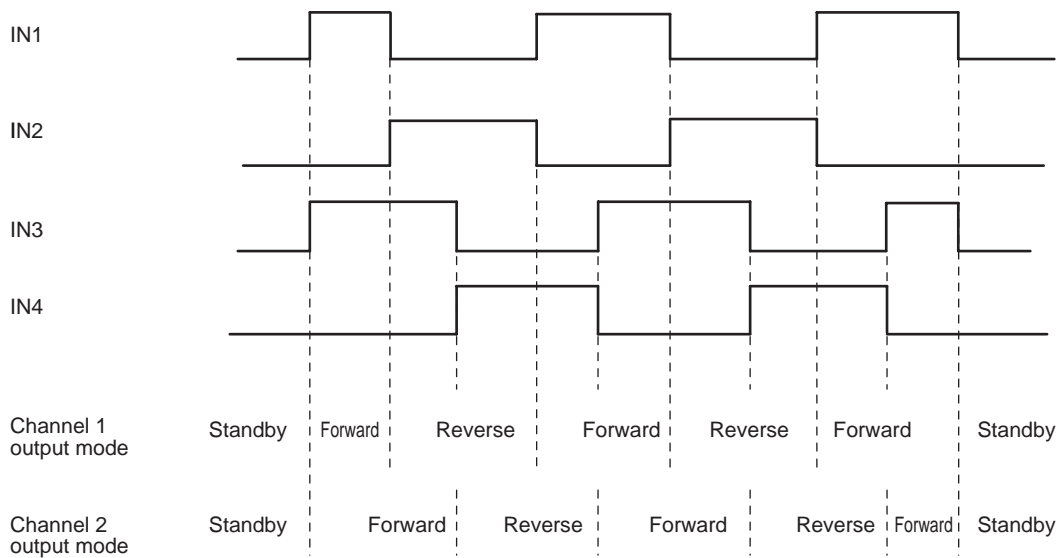

(2) Timing chart for 1-2 phase drive (Slow decay mode)

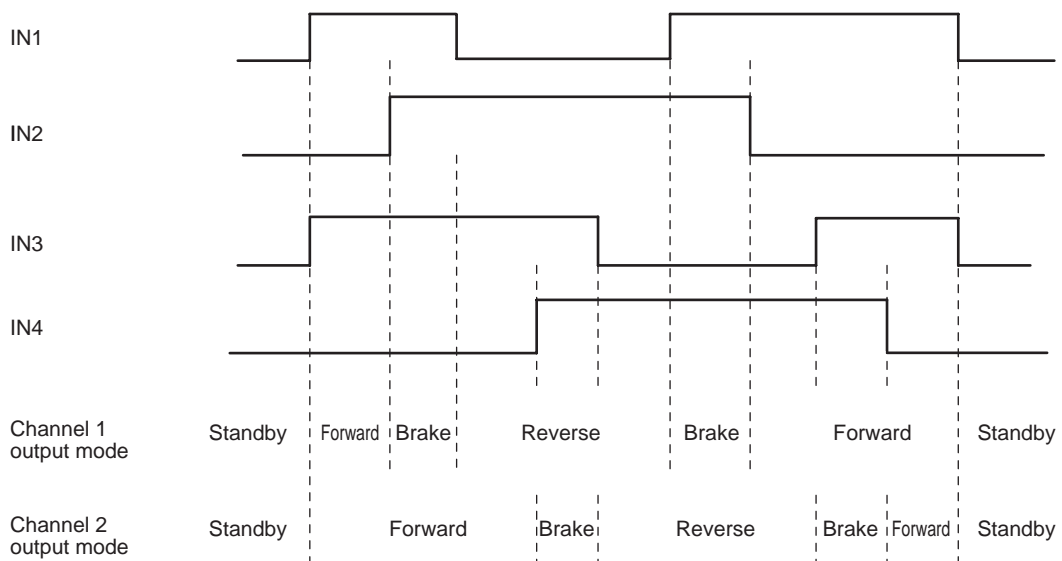

Photosensor Position Detection Application Circuit Example

(a) Application circuit

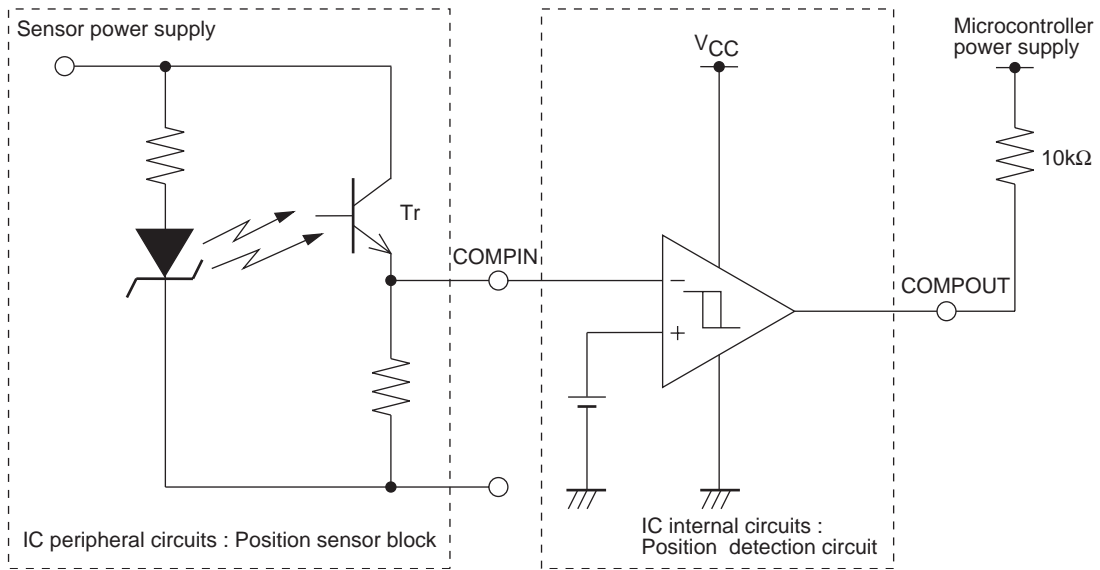

(b) Timing chart

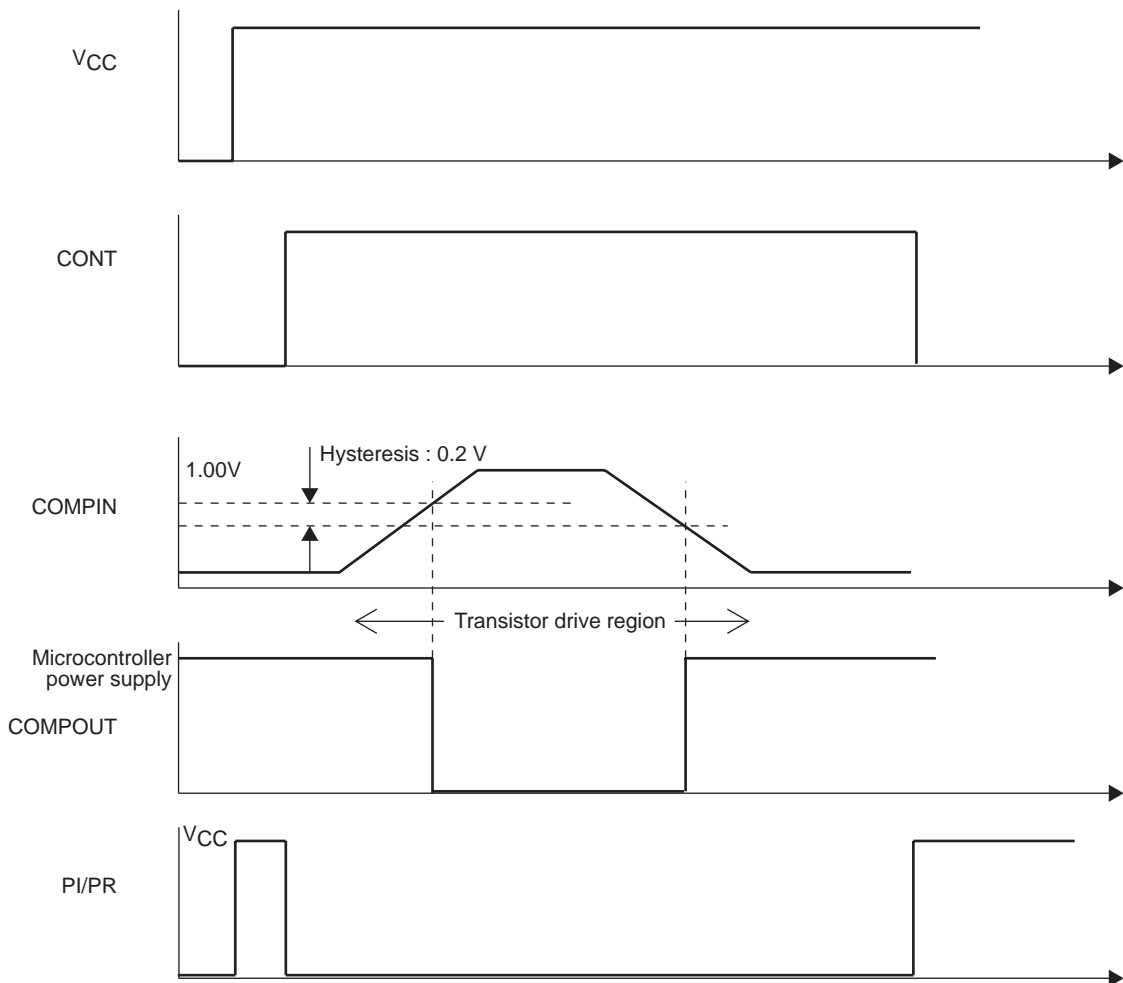

LV8080LP

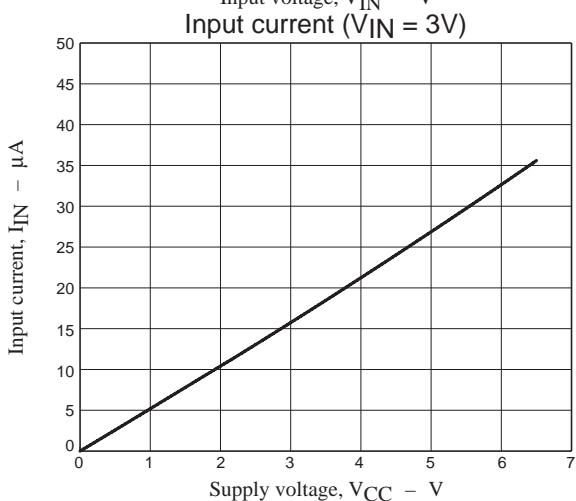
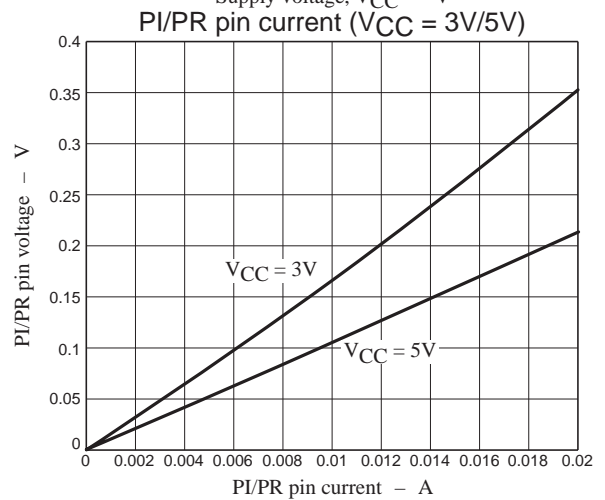
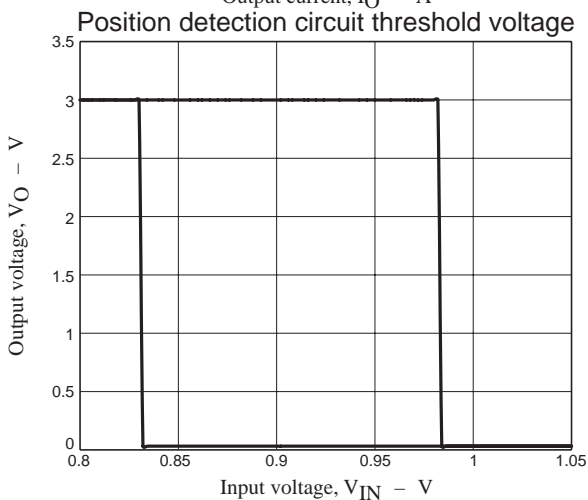
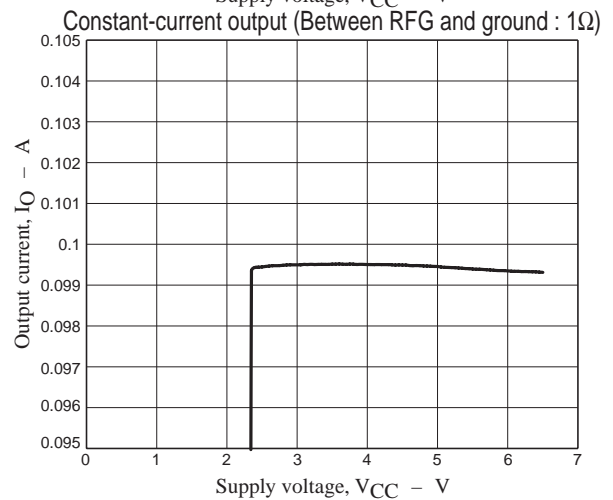
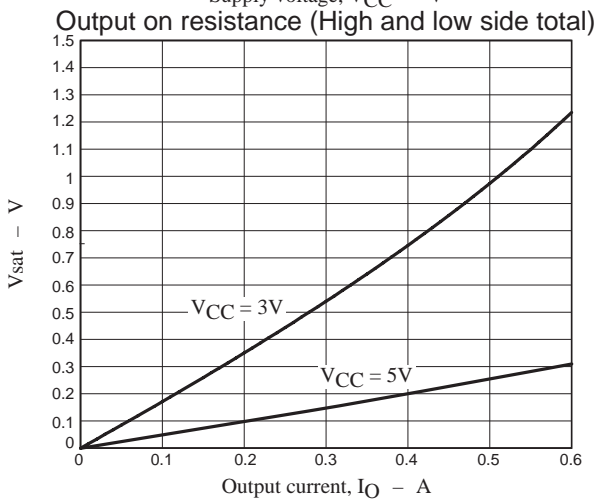
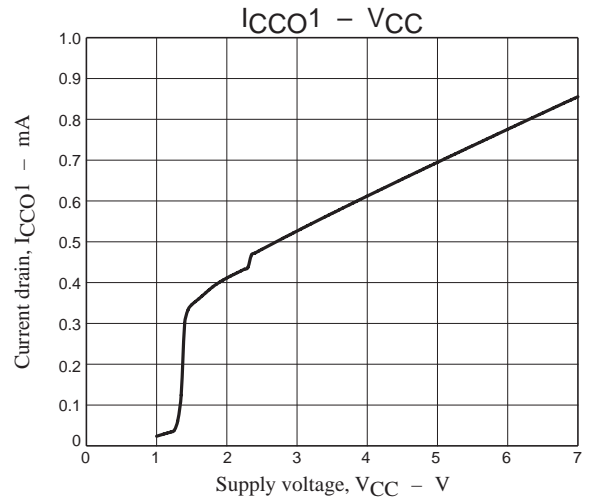
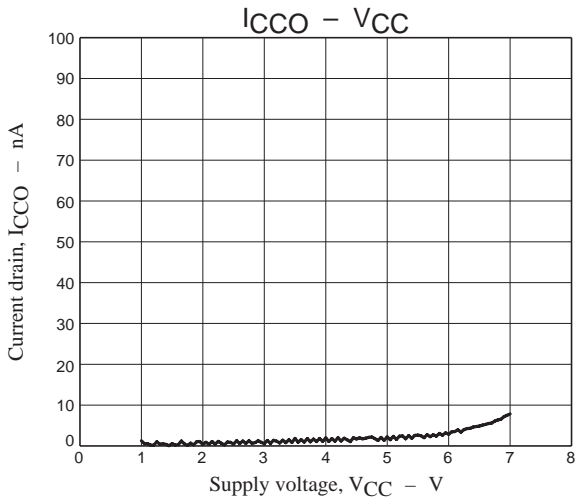

ON Semiconductor and the ON logo are registered trademarks of Semiconductor Components Industries, LLC (SCILLC). SCILLC owns the rights to a number of patents, trademarks, copyrights, trade secrets, and other intellectual property. A listing of SCILLC's product/patent coverage may be accessed at www.onsemi.com/site/pdf/Patent-Marking.pdf. SCILLC reserves the right to make changes without further notice to any products herein. SCILLC makes no warranty, representation or guarantee regarding the suitability of its products for any particular purpose, nor does SCILLC assume any liability arising out of the application or use of any product or circuit, and specifically disclaims any and all liability, including without limitation special, consequential or incidental damages. "Typical" parameters which may be provided in SCILLC data sheets and/or specifications can and do vary in different applications and actual performance may vary over time. All operating parameters, including "Typicals" must be validated for each customer application by customer's technical experts. SCILLC does not convey any license under its patent rights nor the rights of others. SCILLC products are not designed, intended, or authorized for use as components in systems intended for surgical implant into the body, or other applications intended to support or sustain life, or for any other application in which the failure of the SCILLC product could create a situation where personal injury or death may occur. Should Buyer purchase or use SCILLC products for any such unintended or unauthorized application, Buyer shall indemnify and hold SCILLC and its officers, employees, subsidiaries, affiliates, and distributors harmless against all claims, costs, damages, and expenses, and reasonable attorney fees arising out of, directly or indirectly, any claim of personal injury or death associated with such unintended or unauthorized use, even if such claim alleges that SCILLC was negligent regarding the design or manufacture of the part. SCILLC is an Equal Opportunity/Affirmative Action Employer. This literature is subject to all applicable copyright laws and is not for resale in any manner.

X-ON Electronics

Largest Supplier of Electrical and Electronic Components

Click to view similar products for [Motor/Motion/Ignition Controllers & Drivers](#) category:

Click to view products by [ON Semiconductor](#) manufacturer:

Other Similar products are found below :

[FSB50550TB2](#) [FSBF15CH60BTH](#) [MSVCPM2-63-12](#) [MSVGW45-14-2](#) [MSVGW54-14-3](#) [MSVGW54-14-5](#) [NTE7043](#) [LA6565VR-TLM-E](#)
[LB11650-E](#) [LB1837M-TLM-E](#) [LB1845DAZ-XE](#) [LC898300XA-MH](#) [SS30-TE-L-E](#) [26700](#) [LV8281VR-TLM-H](#) [BA5839FP-E2](#) [IRAM236-1067A](#) [LA6584JA-AH](#) [LB11847L-E](#) [NCV70501DW002R2G](#) [AH293-PL-B](#) [STK672-630CN-E](#) [TND315S-TL-2H](#) [FNA23060](#) [FSB50250AB](#)
[FNA41060](#) [MSVB54](#) [MSVBTC50E](#) [MSVCPM3-54-12](#) [MSVCPM3-63-12](#) [MSVCPM4-63-12](#) [MSVTA120](#) [FSB50550AB](#)
[NCV70501DW002G](#) [LC898301XA-MH](#) [LV8413GP-TE-L-E](#) [MSVGW45-14-3](#) [MSVGW45-14-4](#) [MSVGW45-14-5](#) [MSVGW54-14-4](#)
[STK984-091A-E](#) [MP6519GQ-Z](#) [LB11651-E](#) [IRSM515-025DA4](#) [LV8127T-TLM-H](#) [MC33812EKR2](#) [NCP81382MNTXG](#) [TDA21801](#)
[LB11851FA-BH](#) [NCV70627DQ001R2G](#)