



# LV8402GP

## Bi-CMOS IC 2ch Forward/Reverse Motor Driver

ON Semiconductor®

<http://onsemi.com>

### Overview

LV8402GP is a 2ch forward/reverse motor driver IC using D-MOS FET for output stage. As MOS circuit is used, it supports the PWM input. Its features are that the on resistance (0.75Ω typ) and current dissipation are low. It also provides protection functions such as heat protection circuit and reduced voltage detection and is optimal for the motors that need high-current.

### Functions

- 2ch forward/reverse motor driver.
- Low power consumption.
- Low ON resistance 0.75Ω.
- Built-in EXTRA mode for PWM port reduction when a motor drives by two phase excitation.
- Built-in low voltage reset and thermal shutdown circuit.
- 4 mode function forward/reverse, brake and standby.
- Built-in charge pump.

### Specifications

**Maximum Ratings** at Ta = 25°C, SGND = PGND = 0V

Parameter	Symbol	Conditions	Ratings	Unit
Power supply voltage (for load)	VM max		-0.5 to 16.0	V
Power supply voltage (for control)	V <sub>CC</sub> max		-0.5 to 6.0	V
Output current	I <sub>O</sub> max		1.4	A
Output peak current	I <sub>O</sub> peak	t ≤ 10ms	2.5	A
Input voltage	V <sub>IN</sub> max		-0.5 to V <sub>CC</sub> +0.5	V
Allowable power dissipation	Pd max	Mounted on a specified board*	1050	mW
Operating temperature	T <sub>opr</sub>		-30 to +85	°C
Storage temperature	T <sub>stg</sub>		-55 to +150	°C

\* Specified board: 40.0mm × 50.0mm × 0.8mm, 4 Layer glass epoxy board.

Caution 1) Absolute maximum ratings represent the value which cannot be exceeded for any length of time.

Caution 2) Even when the device is used within the range of absolute maximum ratings, as a result of continuous usage under high temperature, high current, high voltage, or drastic temperature change, the reliability of the IC may be degraded. Please contact us for the further details.

Stresses exceeding Maximum Ratings may damage the device. Maximum Ratings are stress ratings only. Functional operation above the Recommended Operating Conditions is not implied. Extended exposure to stresses above the Recommended Operating Conditions may affect device reliability.

**Allowable Operating Conditions** at Ta = 25°C, SGND = PGND = 0V

Parameter	Symbol	Conditions	Ratings	Unit
Power supply voltage (VM pin)	VM	Case except the start operation of the charge pump circuit	1.5 to 15.0	V
Power supply voltage (VM pin)	VM		1.8 to 15.0	V
Power supply voltage (V <sub>CC</sub> pin)	V <sub>CC</sub>		2.8 to 5.5	V
Input signal voltage	V <sub>IN</sub>		0 to V <sub>CC</sub>	V
Input signal frequency	f max		200	kHz

### ORDERING INFORMATION

See detailed ordering and shipping information on page 6 of this data sheet.

# LV8402GP

**Electrical Characteristics** Ta = 25°C, VCC = 3.0V, VM = 6.0V, SGND = PGND = 0V, unless otherwise specified.

Parameter	Symbol	Conditions	Remarks	Ratings			Unit		
				min	typ	max			
Standby load current drain	IMO	EN1=EN2=0V, EXTRA=3V	1			1.0	μA		
Standby control current drain	ICO	EN1=EN2=IN1=IN2=IN3=IN4=0V	2			1.0	μA		
Operating control current drain	IC1	EN=3V, with no load	3		0.85	1.2	mA		
High-level input voltage	V <sub>IH</sub>	2.7 ≤ V <sub>CC</sub> ≤ 5.5V		0.6×V <sub>CC</sub>		V <sub>CC</sub>	V		
Low-level input voltage	V <sub>IL</sub>	2.7 ≤ V <sub>CC</sub> ≤ 5.5V		0		0.2×V <sub>CC</sub>	V		
High-level input current (IN1, IN2, IN3, IN4, EN1, EN2)	I <sub>IH</sub>	V <sub>IN</sub> = 3V	4		15	25	μA		
Low-level input current (IN1, IN2, IN3, IN4, EN1, EN2)	I <sub>IL</sub>	V <sub>IN</sub> = 0V	4	-1.0			μA		
Pull-down resistance value	RDN	IN1, IN2, IN3, IN4, EN1, EN2	4	100	200	400	kΩ		
High-level input current 2 (IN1, IN2, IN3, IN4, EN1, EN2)	I <sub>IH2</sub>	V <sub>IN</sub> = 3V	5			1.0	μA		
Low-level input current 2 (IN1, IN2, IN3, IN4, EN1, EN2)	I <sub>IL2</sub>	V <sub>IN</sub> = 0V	5	-25	-15		μA		
Pull-up resistance value	RUP	EXTRA	5	100	200	400	kΩ		
Charge pump voltage	VG	V <sub>CC</sub> + VM		8.5	9.0	9.5	V		
Output ON resistance 1	RON1	Sum of top and bottom sides ON resistance.	6		0.75	1.2	Ω		
Output ON resistance 2	RON2	Sum of top and bottom sides ON resistance. V <sub>CC</sub> = 2.8V	6		1.0	1.5	Ω		
Low-voltage detection voltage	VCS	V <sub>CC</sub> pin voltage is monitored	7	2.15	2.30	2.45	V		
Thermal shutdown temperature	Tth	Design guarantee value *	8	150	180	210	°C		
Output block	Turn-on time	TPLH	When no load. Design guarantee value *	9		0.3	0.5	μS	
							100	200	nS
	Turn-off time	TPHL	When no load. Design guarantee value *	9			0.35	0.6	μS
								100	200

\* : Design guarantee value and no measurement is performed.

## Remarks

1. Current consumption when output at the VM pin is off.
2. Current consumption at the VCC for standby mode.
3. EN1=3V (IC starts) shows the current consumption of the VCC pin.
4. Pins IN 1, 2, 3, 4, EN1, and EN2 are all pulled down according to resistance.
5. EXTRA pin is pulled up according to resistance.
6. Sum of upper and lower saturation voltages of OUT pin divided by the current.
7. All power transistors are turned off if a low VCC condition is detected.
8. All output transistors are turned off if the thermal protection circuit is activated. They are turned on again as the temperature goes down.
9. Rising time from 10% to 90% and falling time from 90% to 10% are specified.
10. The change of the voltage of the input pin provides for time until the voltage of the terminal OUT changes by 10% at the time of 50% of VCC.

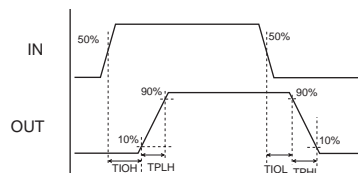

# LV8402GP

## Package Dimensions

unit : mm (typ)

3322A

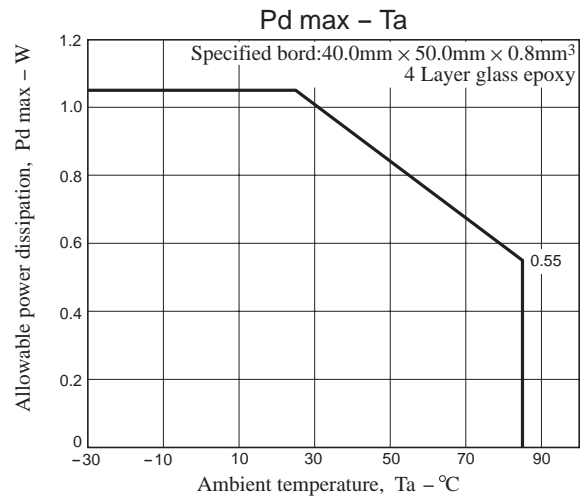
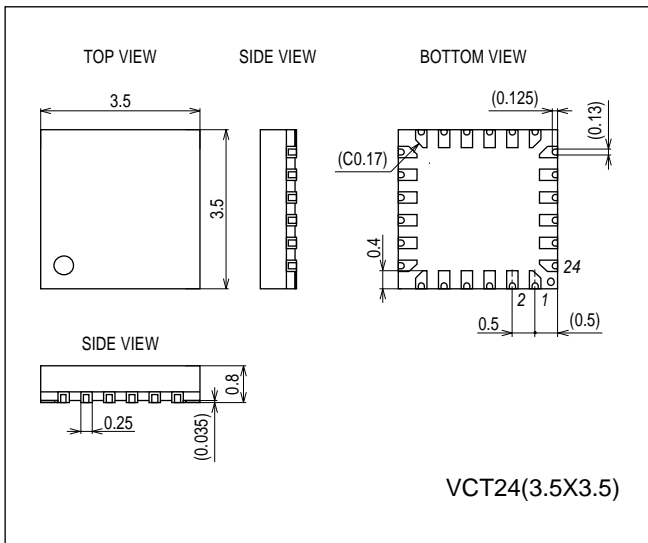

## Pin Assignment

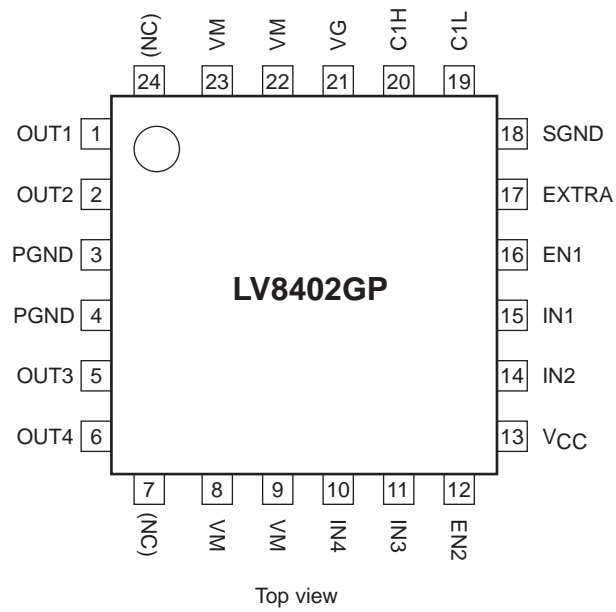

Block Diagram

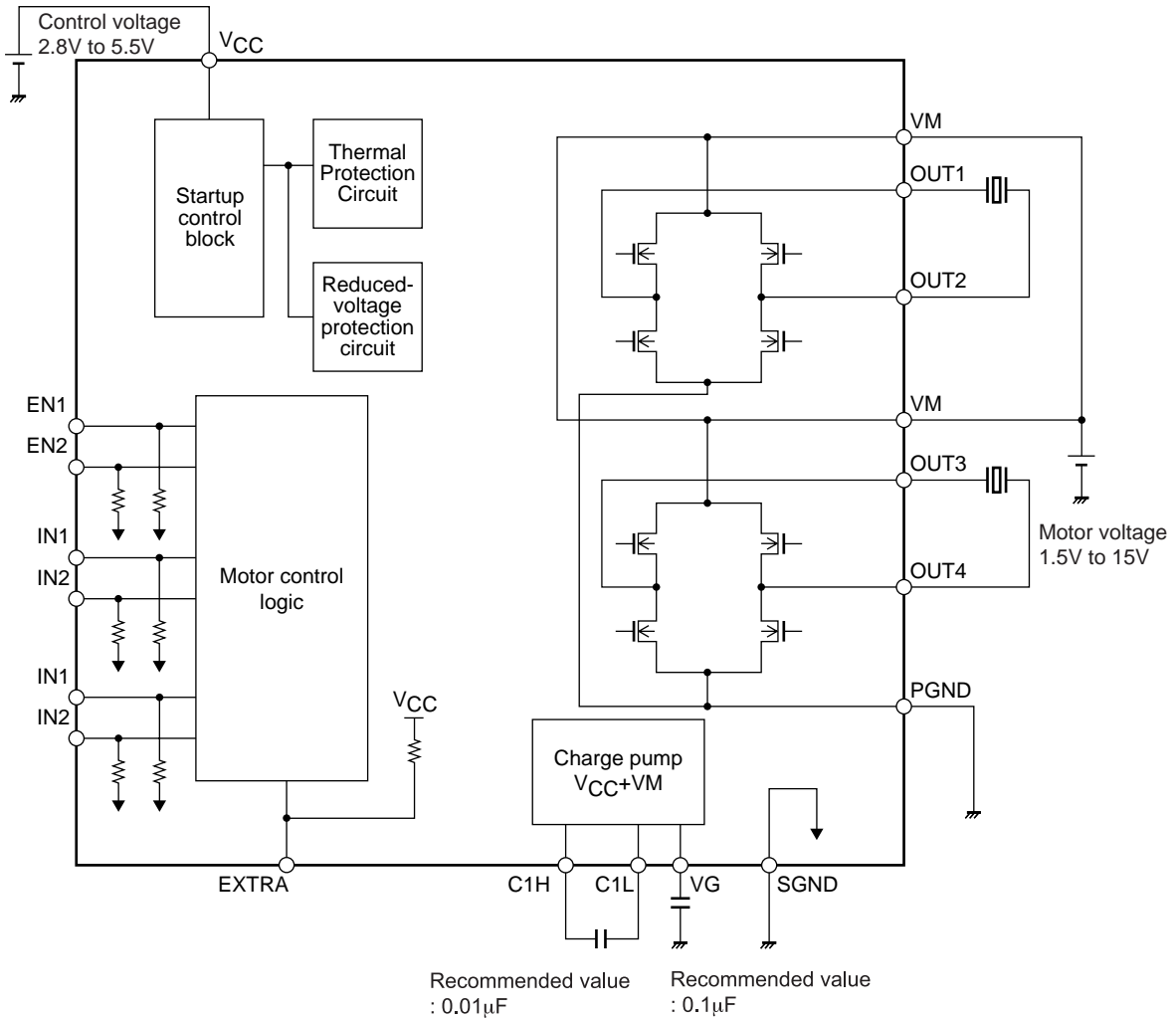

\* Connect a kickback absorption capacitor as near as possible to the IC. Coil kickback may cause increase in VM line voltage, and a voltage exceeding the maximum rating may be applied momentarily to the IC, which results in deterioration or damage of the IC

Truth Table

EXTRA	EN1 (EN2)	IN1 (IN3)	IN2 (IN4)	OUT1 (OUT3)	OUT2 (OUT4)	Charge pump	Mode
H	H	H	H	Z	Z	ON	Stand-by
		H	L	L	H		Reverse
		L	H	H	L		Forward
		L	L	L	L		Brake
	L	-	-	L	L	OFF	Stand-by
L	H	H	-	L	H	ON	Reverse
		L	-	H	L		Forward
		L	-	L	L		Brake

- : denotes a don't care value. Z: High-Impedance

• In the standby mode, current consumption vanishes.

\* All power transistors turn off and the motor stops driving when the IC is detected in low voltage or thermal protection mode.

# LV8402GP

## Pin Functions

Pin No.	Pin name	Description	Equivalent circuit
20 21	C1H VG	Step-up capacitor connection pin.	
17	EXTRA	Extra logic pin. (Logic switch for PWM)	
16 12 15 14 11 10	EN1 EN2 IN1 IN2 IN3 IN4	Driver output switching. Logic enable pin. (Pull-down resistor incorporated)	
1 2 5 6	OUT1 OUT2 OUT3 OUT4	Driver output.	
8, 9, 22, 23	VM	Motor block power supply.	
13	V <sub>CC</sub>	Logic block power supply.	
18	SGND	Control block ground.	
3, 4	PGND	Driver block ground.	

# LV8402GP

---

## ORDERING INFORMATION

Device	Package	Shipping (Qty / Packing)
LV8402GP-TE-L-H	VCT24 (3.5×3.5) (Pb-Free / Halogen Free)	2000 / Tape & Reel
LV8402GP-H	VCT24 (3.5×3.5) (Pb-Free / Halogen Free)	490 / Tray JEDEC

ON Semiconductor and the ON logo are registered trademarks of Semiconductor Components Industries, LLC (SCILLC). SCILLC owns the rights to a number of patents, trademarks, copyrights, trade secrets, and other intellectual property. A listing of SCILLC's product/patent coverage may be accessed at [www.onsemi.com/site/pdf/Patent-Marking.pdf](http://www.onsemi.com/site/pdf/Patent-Marking.pdf). SCILLC reserves the right to make changes without further notice to any products herein. SCILLC makes no warranty, representation or guarantee regarding the suitability of its products for any particular purpose, nor does SCILLC assume any liability arising out of the application or use of any product or circuit, and specifically disclaims any and all liability, including without limitation special, consequential or incidental damages. "Typical" parameters which may be provided in SCILLC data sheets and/or specifications can and do vary in different applications and actual performance may vary over time. All operating parameters, including "Typicals" must be validated for each customer application by customer's technical experts. SCILLC does not convey any license under its patent rights nor the rights of others. SCILLC products are not designed, intended, or authorized for use as components in systems intended for surgical implant into the body, or other applications intended to support or sustain life, or for any other application in which the failure of the SCILLC product could create a situation where personal injury or death may occur. Should Buyer purchase or use SCILLC products for any such unintended or unauthorized application, Buyer shall indemnify and hold SCILLC and its officers, employees, subsidiaries, affiliates, and distributors harmless against all claims, costs, damages, and expenses, and reasonable attorney fees arising out of, directly or indirectly, any claim of personal injury or death associated with such unintended or unauthorized use, even if such claim alleges that SCILLC was negligent regarding the design or manufacture of the part. SCILLC is an Equal Opportunity/Affirmative Action Employer. This literature is subject to all applicable copyright laws and is not for resale in any manner.

## X-ON Electronics

Largest Supplier of Electrical and Electronic Components

*Click to view similar products for [Motor/Motion/Ignition Controllers & Drivers](#) category:*

*Click to view products by [ON Semiconductor](#) manufacturer:*

Other Similar products are found below :

[FSB50550TB2](#) [FSBF15CH60BTH](#) [MSVCPM2-63-12](#) [MSVGW45-14-2](#) [MSVGW54-14-3](#) [MSVGW54-14-5](#) [NTE7043](#) [LA6565VR-TLM-E](#)  
[LB11650-E](#) [LB1837M-TLM-E](#) [LB1845DAZ-XE](#) [LC898300XA-MH](#) [SS30-TE-L-E](#) [26700](#) [LV8281VR-TLM-H](#) [BA5839FP-E2](#) [IRAM236-1067A](#) [LA6584JA-AH](#) [LB11847L-E](#) [NCV70501DW002R2G](#) [AH293-PL-B](#) [STK672-630CN-E](#) [TND315S-TL-2H](#) [FNA23060](#) [FSB50250AB](#)  
[FNA41060](#) [MSVB54](#) [MSVBTC50E](#) [MSVCPM3-54-12](#) [MSVCPM3-63-12](#) [MSVCPM4-63-12](#) [MSVTA120](#) [FSB50550AB](#)  
[NCV70501DW002G](#) [LC898301XA-MH](#) [LV8413GP-TE-L-E](#) [MSVGW45-14-3](#) [MSVGW45-14-4](#) [MSVGW45-14-5](#) [MSVGW54-14-4](#)  
[STK984-091A-E](#) [MP6519GQ-Z](#) [LB11651-E](#) [IRSM515-025DA4](#) [LV8127T-TLM-H](#) [MC33812EKR2](#) [NCP81382MNTXG](#) [TDA21801](#)  
[LB11851FA-BH](#) [NCV70627DQ001R2G](#)