



LV8417CS

Bi-CMOS IC Forward/Reverse Motor Driver

ON Semiconductor®

<http://onsemi.com>

Overview

The LV8417CS is a 1-channel H bridge motor driver IC. The package size is extremely small with wafer level package (WLP). Moreover, the on-resistance is low (upper and lower total 0.27Ω typ.).

The application voltage range is wide (2.0V to 10.5V).

The H bridge of this IC is P-N composition and thereby reduces the external parts without need of charge pump.

Therefore, LV8417CS realizes reduction of mounting area which enables lower cost and smaller application size.

Functions

- H-bridge 1-channel forward/reverse motor driver
- BiCDMOS process
- Output ON resistance (Upper and lower total 0.27Ω; Ts=25°C, IO=1.0A)
- IO max=1.0A (t≤100ms 2.0A, t≤10ms 3.8A)
- Built-in low voltage reset and thermal shutdown circuit

Specifications

Maximum Ratings at Ta = 25°C, SGND = PGND = 0V

Parameter	Symbol	Conditions	Ratings	Unit
Power supply voltage (for load)	V _M max		-0.5 to 12.6	V
Power supply voltage (for control)	V _{CC} max		-0.5 to 6.0	V
Output current	I _O max		1.0	A
Output peak current	I _O peak1	t ≤ 100ms	2.0	A
	I _O peak2	t ≤ 10ms	3.8	A
Input voltage	V _{IN} max		-0.5 to V _{CC} +0.5	V
Allowable power dissipation	P _d max	Mounted on a specified board *	850	mW
Operating temperature	T _{opr}		-20 to +85	°C
Storage temperature	T _{stg}		-55 to +150	°C

* Specified board : 57mm × 57mm × 1.6mm, glass epoxy both side board.

Caution 1) Absolute maximum ratings represent the value which cannot be exceeded for any length of time.

Caution 2) Even when the device is used within the range of absolute maximum ratings, as a result of continuous usage under high temperature, high current, high voltage, or drastic temperature change, the reliability of the IC may be degraded. Please contact us for the further details.

Stresses exceeding Maximum Ratings may damage the device. Maximum Ratings are stress ratings only. Functional operation above the Recommended Operating Conditions is not implied. Extended exposure to stresses above the Recommended Operating Conditions may affect device reliability.

LV8417CS

Allowable Operating Conditions at $T_a = 25^\circ\text{C}$, $\text{SGND} = \text{PGND} = 0\text{V}$

Parameter	Symbol	Conditions	Ratings	Unit
Power supply voltage (V_M pin)	V_M		2.0 to 10.5	V
Power supply voltage (V_{CC} pin)	V_{CC}		2.7 to 5.5	V
Input signal voltage	V_{IN}		0 to V_{CC}	V
Input signal frequency	f_{max}	Duty = 50%	200	kHz

Electrical Characteristics $T_a = 25^\circ\text{C}$, $V_{CC} = 3.0\text{V}$, $V_M = 6.0\text{V}$, $\text{SGND} = \text{PGND} = 0\text{V}$

Parameter	Symbol	Conditions	Remarks	Ratings			Unit
				min	typ	max	
Standby load current drain	I_{MO}	$\text{ENA} = 0\text{V}$	1			1.0	μA
Operating load current drain	I_{M1}	$\text{ENA} = 3.0\text{V}$, No load	3		80	120	μA
Standby control current drain	I_{CO}	$\text{ENA} = \text{IN1} = \text{IN2} = 0\text{V}$	2			1.0	μA
Operating current consumption 1	I_{C1}	$\text{ENA} = 3.0\text{V}$, No load	3		0.5	0.8	mA
High-level input voltage	V_{IH}	$2.7 \leq V_{CC} \leq 5.5\text{V}$		$0.6 \times V_{CC}$		V_{CC}	V
Low-level input voltage	V_{IL}	$2.7 \leq V_{CC} \leq 5.5\text{V}$		0		$0.2 \times V_{CC}$	V
High-level input current ($\text{ENA}, \text{IN1}, \text{IN2}$)	I_{IH1}	$V_{IN} = 3\text{V}$			20	30	μA
Low-level input current ($\text{ENA}, \text{IN1}, \text{IN2}$)	I_{IL1}	$V_{IN} = 0\text{V}$		-1.0			μA
Pull-down resistance value	R_{DN}	$\text{ENA}, \text{IN1}, \text{IN2}$	4	100	200	400	k Ω
Output ON resistance	R_{ON}	Sum of top and bottom sides ON resistance.	5		0.27	0.4	Ω
Low-voltage detection operating voltage	V_{CS1}	V_{CC} pin voltage	6	2.1	2.3	2.5	V
Low-voltage detection release voltage	V_{CS2}	V_{CC} pin voltage	6	2.3	2.5	2.7	V
Thermal shutdown temperature	T_{th}	Design guarantee *	7	150	180	210	$^\circ\text{C}$
Output block	Turn-on time	T_{PLH}	8		0.10	0.15	μs
	Output response time H	T_{IOH}	9		0.23	0.35	μs
	Turn-off time	T_{PHL}	8		0.10	0.15	μs
	Output response time L	T_{IOL}	9		0.25	0.38	μs

Remarks

- Current consumption when output at the V_M pin is off.
- Current consumption at the V_{CC} pin when in all function stop.
- Current consumption at the V_{CC} pin when $\text{ENA}=3\text{V}$ (IC starting time).
- $\text{ENA}, \text{IN1}$ and IN2 pin have an internal pull-down resistor.
- The saturation voltage of the bottom above an OUT pin is added, and the value broken by the current value is shown.
- All output transistors are turned off if a low-voltage is detected for V_{CC} .
- All output transistors are turned off if the thermal protection circuit is activated. They are turned on again as the temperature goes down.
- Rising time from 10% to 90% and falling time from 90% to 10% are specified.
- Time until it changes OUT pin voltage 10% from the time of change of input pin voltage being 50% of V_{CC} is specified.

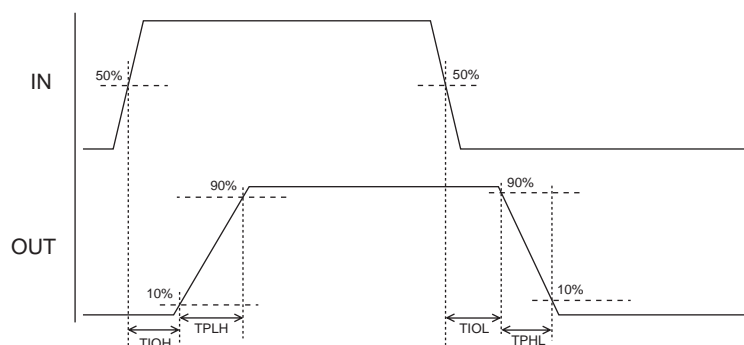

LV8417CS

Package Dimensions

unit : mm (typ)

3418

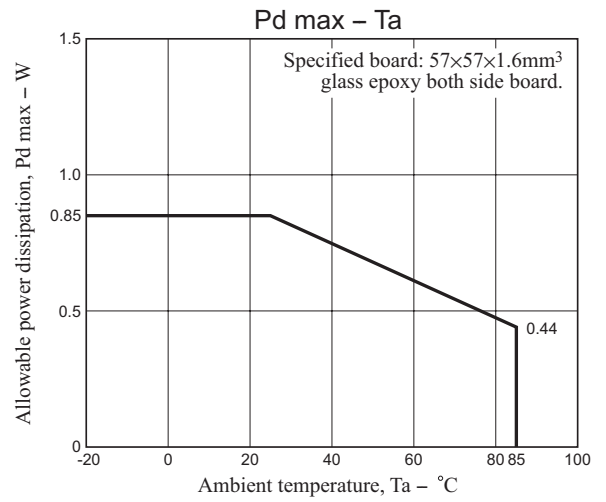
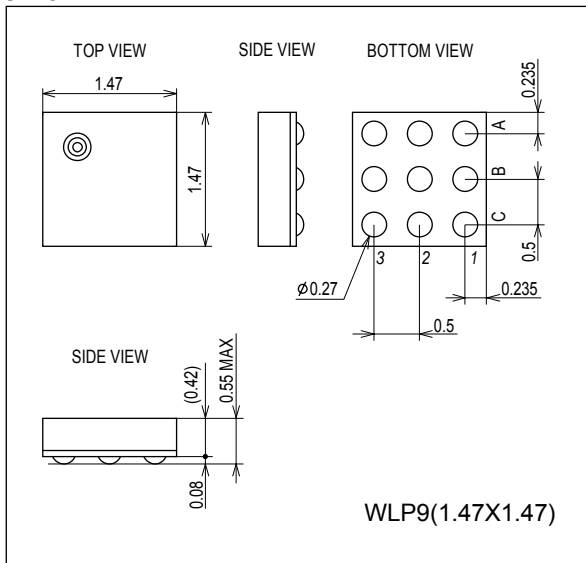

Pin Assignment

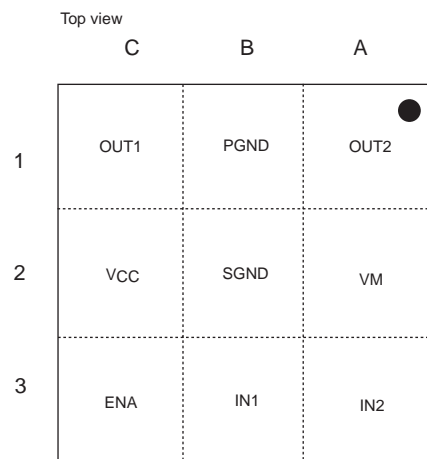
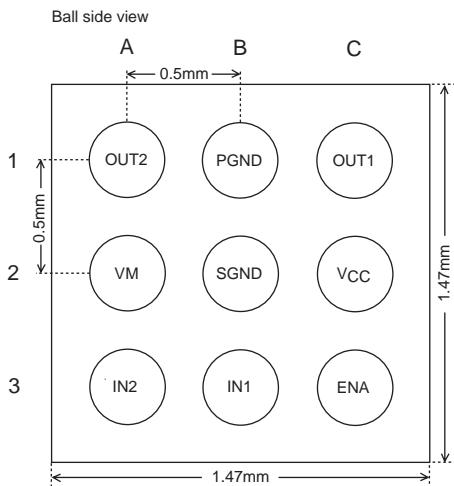

Block Diagram

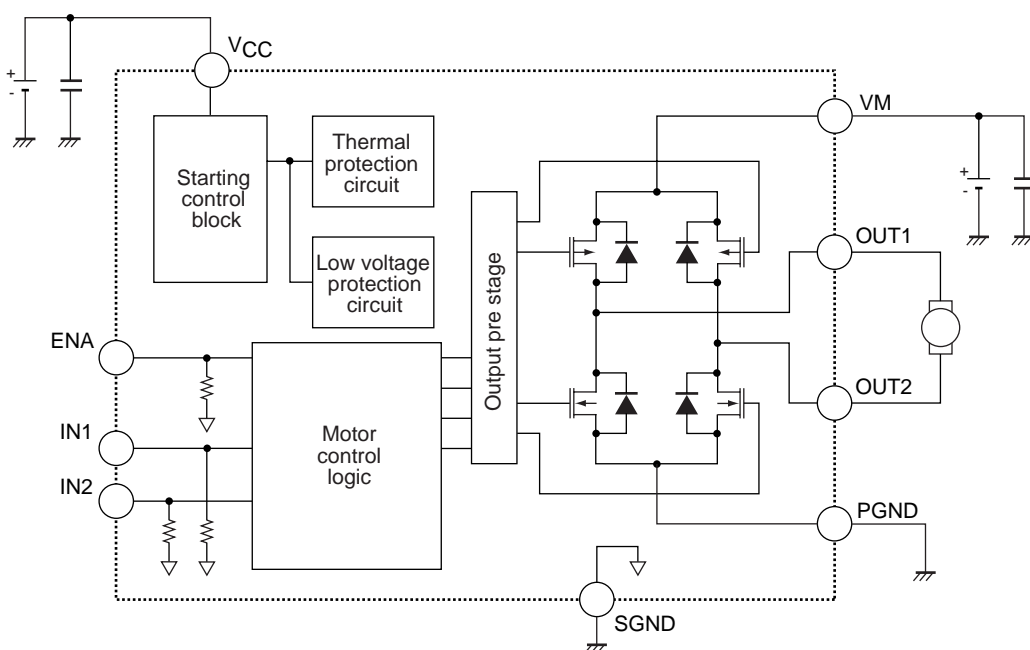

LV8417CS

Pin Functions

Pin No.	Pin name	Description	Equivalent circuit
C-3 B-3 A-3 C-2 B-2	ENA IN1 IN2 V _{CC} SGND	Logic enable pin Driver output change pin Driver output change pin Power supply for control Ground pin for control	
A-2 C-1 A-1 B-1	V _M OUT1 OUT2 PGND	Power supply for load Driver output pin Driver output pin Ground pin for load	

Truth Table

ENA	IN1	IN2	OUT1	OUT2	Mode
L	-	-	Z	Z	All function stop
H	L	L	Z	Z	Standby
	H	L	H	L	Forward
	L	H	L	H	Reverse
	H	H	L	L	Brake

- : denotes a don't care value. Z : High-impedance

- Current drain is zero in all function stop mode.
- All power transistors turn off and the motor stops driving when the IC is detected in low voltage or thermal protection mode.

LV8417CS

Sample Application Circuit

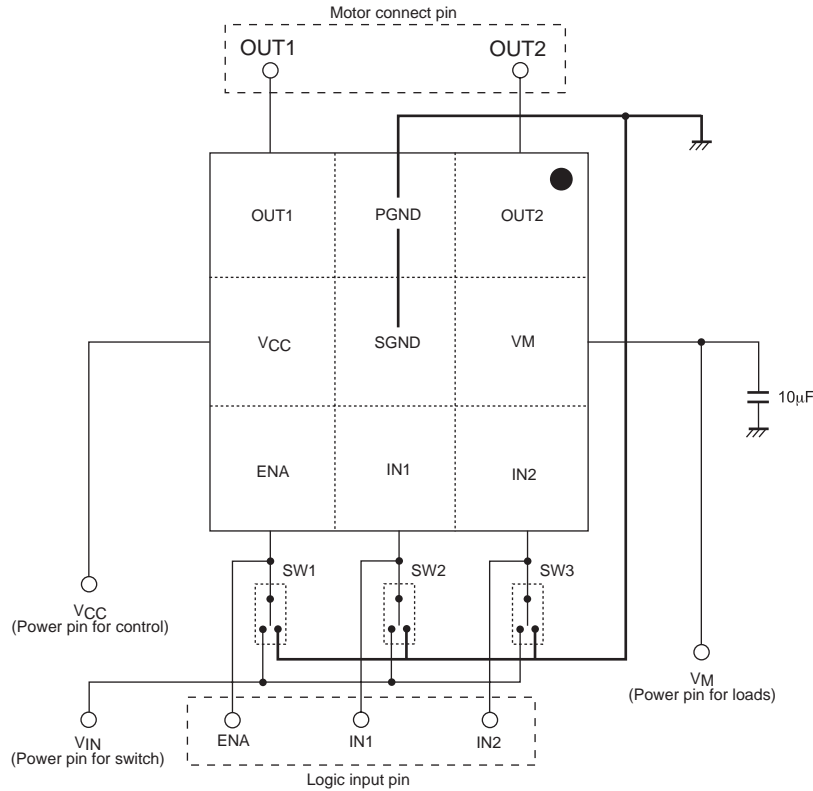

* Connect a kickback absorbing capacitor as close as possible to the IC. Characteristics deterioration of the IC or damage may result if an instantaneous voltage surge exceeding the maximum rated value is applied to the VM line due to coil kickback or other causes.

ON Semiconductor and the ON logo are registered trademarks of Semiconductor Components Industries, LLC (SCILLC). SCILLC owns the rights to a number of patents, trademarks, copyrights, trade secrets, and other intellectual property. A listing of SCILLC's product/patent coverage may be accessed at www.onsemi.com/site/pdf/Patent-Marking.pdf. SCILLC reserves the right to make changes without further notice to any products herein. SCILLC makes no warranty, representation or guarantee regarding the suitability of its products for any particular purpose, nor does SCILLC assume any liability arising out of the application or use of any product or circuit, and specifically disclaims any and all liability, including without limitation special, consequential or incidental damages. "Typical" parameters which may be provided in SCILLC data sheets and/or specifications can and do vary in different applications and actual performance may vary over time. All operating parameters, including "Typicals" must be validated for each customer application by customer's technical experts. SCILLC does not convey any license under its patent rights nor the rights of others. SCILLC products are not designed, intended, or authorized for use as components in systems intended for surgical implant into the body, or other applications intended to support or sustain life, or for any other application in which the failure of the SCILLC product could create a situation where personal injury or death may occur. Should Buyer purchase or use SCILLC products for any such unintended or unauthorized application, Buyer shall indemnify and hold SCILLC and its officers, employees, subsidiaries, affiliates, and distributors harmless against all claims, costs, damages, and expenses, and reasonable attorney fees arising out of, directly or indirectly, any claim of personal injury or death associated with such unintended or unauthorized use, even if such claim alleges that SCILLC was negligent regarding the design or manufacture of the part. SCILLC is an Equal Opportunity/Affirmative Action Employer. This literature is subject to all applicable copyright laws and is not for resale in any manner.

X-ON Electronics

Largest Supplier of Electrical and Electronic Components

Click to view similar products for [Power Management IC Development Tools](#) *category:*

Click to view products by [ON Semiconductor](#) *manufacturer:*

Other Similar products are found below :

[EVAL-ADM1168LQEBZ](#) [EVB-EP5348UI](#) [MIC23451-AAAYFL EV](#) [MIC5281YMME EV](#) [DA9063-EVAL](#) [ADP122-3.3-EVALZ](#) [ADP130-0.8-EVALZ](#) [ADP130-1.2-EVALZ](#) [ADP130-1.5-EVALZ](#) [ADP130-1.8-EVALZ](#) [ADP1712-3.3-EVALZ](#) [ADP1714-3.3-EVALZ](#) [ADP1715-3.3-EVALZ](#) [ADP1716-2.5-EVALZ](#) [ADP1740-1.5-EVALZ](#) [ADP1752-1.5-EVALZ](#) [ADP1828LC-EVALZ](#) [ADP1870-0.3-EVALZ](#) [ADP1871-0.6-EVALZ](#) [ADP1873-0.6-EVALZ](#) [ADP1874-0.3-EVALZ](#) [ADP1882-1.0-EVALZ](#) [ADP199CB-EVALZ](#) [ADP2102-1.25-EVALZ](#) [ADP2102-1.875EVALZ](#) [ADP2102-1.8-EVALZ](#) [ADP2102-2-EVALZ](#) [ADP2102-3-EVALZ](#) [ADP2102-4-EVALZ](#) [ADP2106-1.8-EVALZ](#) [ADP2147CB-110EVALZ](#) [AS3606-DB](#) [BQ24010EVM](#) [BQ24075TEVM](#) [BQ24155EVM](#) [BQ24157EVM-697](#) [BQ24160EVM-742](#) [BQ24296MEVM-655](#) [BQ25010EVM](#) [BQ3055EVM](#) [NCV891330PD50GEVB](#) [ISLUSBI2CKIT1Z](#) [LM2744EVAL](#) [LM2854EVAL](#) [LM3658SD-AEV/NOPB](#) [LM3658SDEV/NOPB](#) [LM3691TL-1.8EV/NOPB](#) [LM4510SDEV/NOPB](#) [LM5033SD-EVAL](#) [LP38512TS-1.8EV](#)