



ON Semiconductor®

<http://onsemi.com>

LV8498CT

Bi-CMOS IC For VCMs Constant-current Driver IC

Overview

The LV8498CT is a constant current driver IC for voice coil motors that supports I²C control integrating a digital/analog converter (DAC). It uses an ultraminiature WLP package and includes a current detection resistor for constant current control, which makes the IC ideal for miniaturization of camera modules intended for use in camera-equipped mobile phones. The output transistor has a low on-resistance of 1Ω and the resistance of the built-in current detection resistor is 1Ω, which minimizes the voltage loss and helps withstand voltage drop in V_{CC}. The function is incorporated, which, by changing the current in a stepped pattern while taking time at rise and fall of the output current, provides the current a slope, improving the converging stability of the voice coil motor (current slope function).

Functions

- Constant current driver for voice coil motors.
- I²C bus control supported.
- Built-in current detection resistor.
- Built-in voltage drop protection circuit (V_{CC} = 2V output off).
- Built-in thermal protection circuit.
- Low output block total-resistance of 2Ω helps withstand voltage drop in V_{CC}. (Current detection resistance + output transistor on-resistance).
- Built-in VCM overshoot preventive function (current slope function).
- Constant current control enabled by DAC (10 bits).
- Wide operating voltage range (2.2 to 5.0V).
- 6-pin WLP package used (1.27 × 0.87 × 0.25mm).

Specifications

Absolute Maximum Ratings at T_a = 25°C

Parameter	Symbol	Conditions	Ratings	Unit
Maximum supply voltage	V _{CC} max		5.5	V
Output voltage	V _{OUT} max		V _{CC} + 0.5	V
Input voltage	V _{IN} max	SCL, SDA, ENA	5.5	V
GND pin source current	I _{GND}		200	mA
Allowable power dissipation	P _d max	With specified substrate *	350	mW
Operating temperature	T _{opr}		-30 to +85	°C
Storage temperature	T _{stg}		-40 to +150	°C

* Specified substrate : 40mm × 40mm × 1.6mm, Single layer glass epoxy substrate

Stresses exceeding Maximum Ratings may damage the device. Maximum Ratings are stress ratings only. Functional operation above the Recommended Operating Conditions is not implied. Extended exposure to stresses above the Recommended Operating Conditions may affect device reliability.

LV8498CT

Allowable Operating Conditions at $T_a = 25^\circ\text{C}$

Parameter	Symbol	Conditions	Ratings	Unit
Supply voltage	V_{CC}		2.2 to 5.0	V
Maximum preset output current	I_O		150	mA
Input signal voltage	V_{IN}		-0.3 to $V_{CC}+0.3$	V

Electrical Characteristics at $T_a = 25^\circ\text{C}$, $V_{CC} = 2.8\text{V}$

Parameter	Symbol	Conditions	Ratings			Unit
			min	typ	max	
Supply current	I_{CC0a}	ENA = 0V, SCL=SDA= V_{CC}			1	μA
	I_{CC0b}	ENA=SCL=SDA= V_{CC} , PD = 1			1	μA
	I_{CC0c}	ENA=SCL=SDA= V_{CC} , D0 to D9 = 0			1	μA
	I_{CC1}	ENA=SCL=SDA= V_{CC} , D0 to D9 \neq 0		0.5	3	mA
Input current	I_{IN}	SCL, SDA, ENA	-1	0	1	μA
High level input voltage	V_{IH}	Applied to SCL, SDA and ENA pin.	1.5		$V_{CC}-0.3$	V
Low level input voltage	V_{IL}		-0.3		0.5	V
Total resistance value of the output block (built-in resistor + transistor on-resistance)	RTTL	$V_{CC} = 2.8\text{V}$, $I_{OUT} = 80\text{mA}$		2	3	Ω
DAC block						
Resolution				10		bits
Relative accuracy	INL				± 2	LSB
Differential linearity	DNL				± 1	LSB
Full code current	I_{full}	D0 to D9 = 1		150		mA
Error code current 0	I_{zero}	D0 to D9 = 0		0		mA
Spark killer diode						
Reverse current	I_S (leak)				1	μA
Forward voltage	VSF	$I_{OUT}=100\text{mA}$			1.3	V

Package Dimensions

unit : mm (typ)

3390

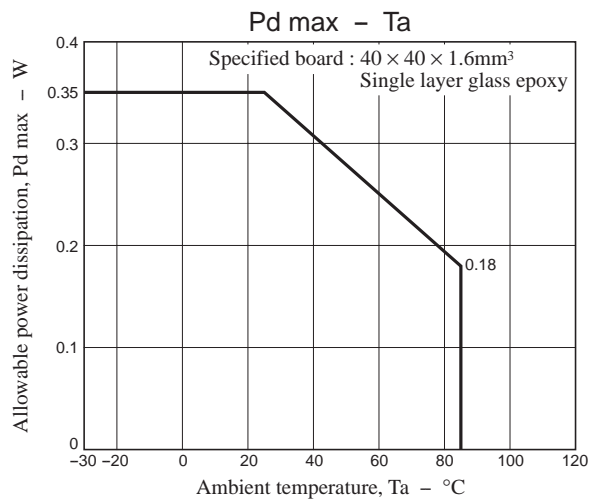
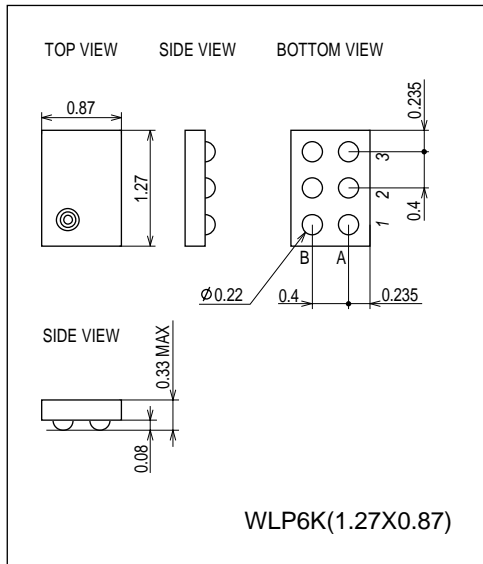

LV8498CT

Pin Assignment

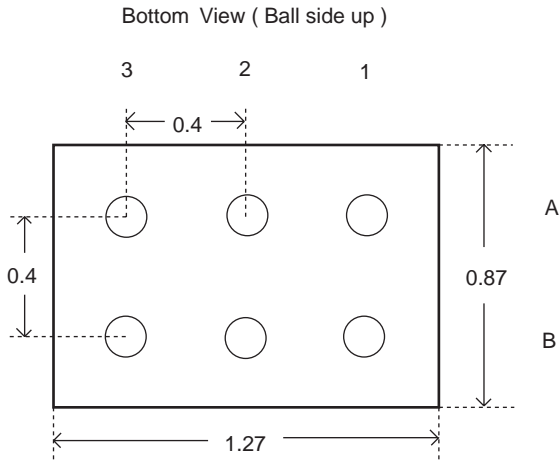

Pin No.	Pin Name	Pin Description
A1	SCL	I ² C SCL input pin
A2	ENA	Enable & reset *1, 2
A3	GND	Ground
B1	SDA	I ² C SDA input pin
B2	V _{CC}	Power supply pin
B3	OUT	Output pin

*1 : Setting the ENA pin to low powers down and resets the IC.

It is necessary to power on the IC by setting the ENA pin to low and hold it high during normal operation.

*2 : When the ENA pin is to be used with pull_up, it is necessary to send code 0 in advance after power-on.

Block Diagram

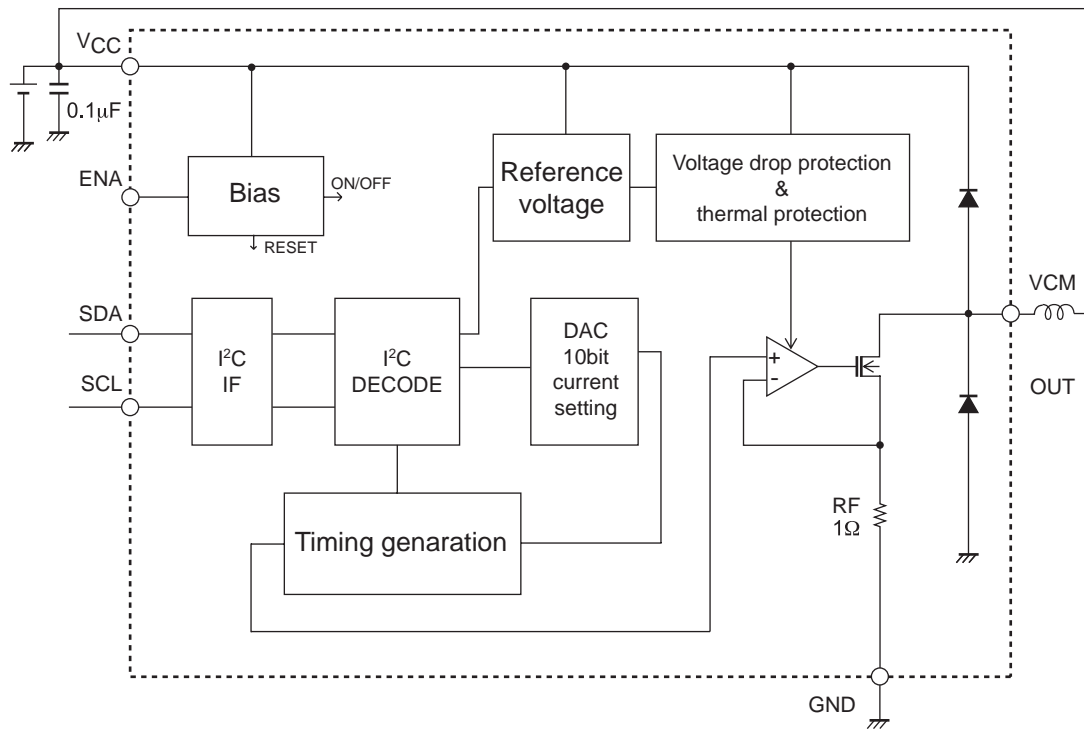

Serial Bus Communication Specifications

I²C serial transfer timing conditions

Standard mode

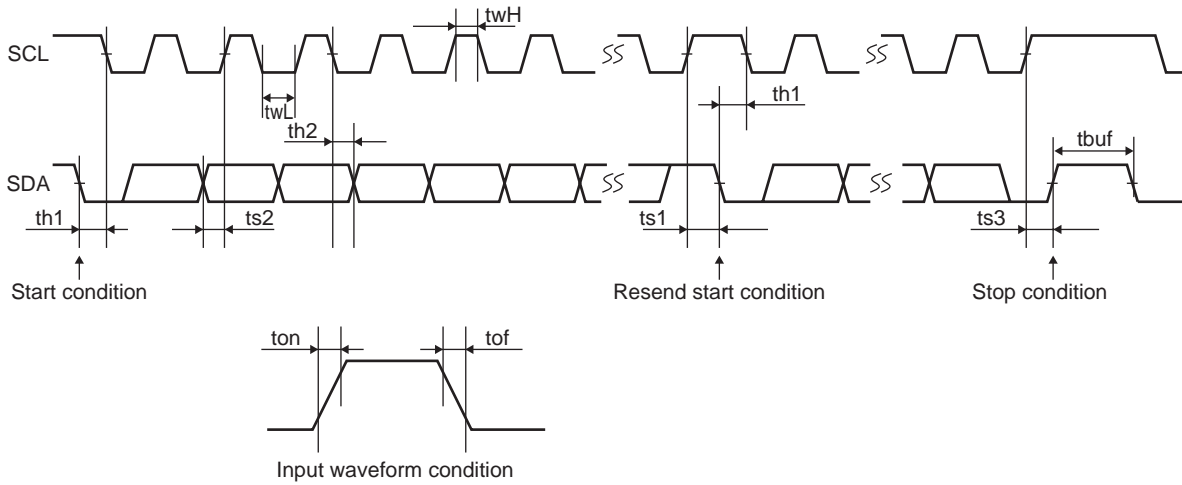

Standard mode

Parameter	symbol	Conditions	min	typ	max	unit
SCL clock frequency	fscL	SCL clock frequency	0		100	kHz
Data setup time	ts1	Setup time of SCL with respect to the falling edge of SDA	4.7			μs
	ts2	Setup time of SDA with respect to the rising edge of SCL	250			ns
	ts3	Setup time of SCL with respect to the rising edge of SDA	4.0			μs
Data hold time	th1	Hold time of SCL with respect to the rising edge of SDA	4.0			μs
	th2	Hold time of SDA with respect to the falling edge of SCL	0			μs
Pulse width	twL	SCL low period pulse width	4.7			μs
	twH	SCL high period pulse width	4.0			μs
Input waveform conditions	ton	SCL, SDA (input) rising time			1000	ns
	tof	SCL, SDA (input) falling time			300	ns
Bus free time	tbuf	Interval between stop condition and start condition	4.7			μs

High-speed mode

Parameter	Symbol	Conditions	min	typ	max	unit
SCL clock frequency	fscL	SCL clock frequency	0		400	kHz
Data setup time	ts1	Setup time of SCL with respect to the falling edge of SDA	0.6			μs
	ts2	Setup time of SDA with respect to the rising edge of SCL	100			ns
	ts3	Setup time of SCL with respect to the rising edge of SDA	0.6			μs
Data hold time	th1	Hold time of SCL with respect to the rising edge of SDA	0.6			μs
	th2	Hold time of SDA with respect to the falling edge of SCL	0			μs
Pulse width	twL	SCL low period pulse width	1.3			μs
	twH	SCL high period pulse width	0.6			μs
Input waveform conditions	ton	SCL, SDA (input) rising time			300	ns
	tof	SCL, SDA (input) falling time			300	ns
Bus free time	tbuf	Interval between stop condition and start condition	1.3			μs

LV8498CT

I²C bus transmission method

Start and stop conditions

The I²C bus requires that the state of SDA be preserved while SCL is high as shown in the timing diagram below during a data transfer operation.

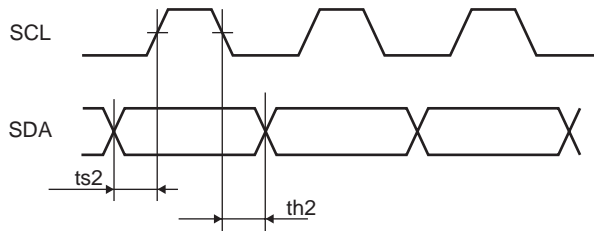

When data is not being transferred, both SCL and SDA are in the high state. The start condition is generated and access is started when SDA is changed from high to low while SCL and SDA are high.

Conversely, the stop condition is generated and access is ended when SDA is changed from low to high while SCL is high.

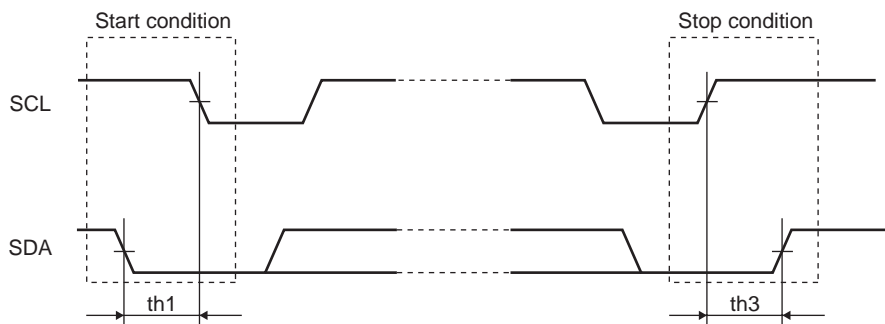

Data transfer and acknowledgement response

After the start condition has been generated, the data is transferred one byte (8 bits) at a time. Generally, in an I²C bus, a unique 7-bit slave address is assigned to each device, and the first byte of the transfer data is allocated to the 7-bit slave address and to the command (R/W) indicating the transfer direction of the subsequent data. However, this IC is provided with only a write mode for receiving the data. Every time 8 bits of data for each byte are transferred, the ACK signal is sent from the receiving end to the sending end. Immediately after the clock pulse of SCL bit 8 in the data transferred has fallen to low, SDA at the sending end is released, and SDA is set to low at the receiving end, causing the ACK signal to be sent. When, after the receiving end has sent the ACK signal, the transfer of the next byte remains in the receiving status, the receiving end releases SDA at the falling edge of the ninth SCL clock.

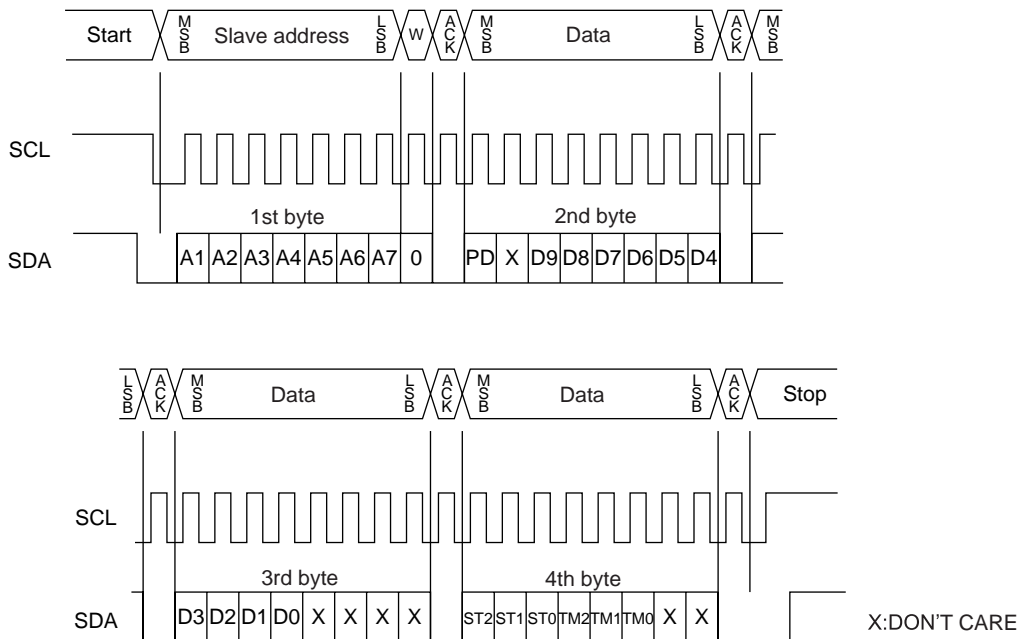

LV8498CT

The standard data transfer to this device consists of four bytes : the slave address of the first byte and the data of the second, third and four bytes.

Slave address : 0110011(0)

PD : Power-down

The table below shows the format of the second , third and four bytes.

	2nd byte								3rd byte							
Serial data bits	SD7	SD6	SD5	SD4	SD3	SD2	SD1	SD0	SD7	SD6	SD5	SD4	SD3	SD2	SD1	SD0
Function	PD	x	D9	D8	D7	D6	D5	D4	D3	D2	D1	D0	x	x	x	x

4th byte							
SD7	SD6	SD5	SD4	SD3	SD2	SD1	SD0
ST2	ST1	ST0	TM2	TM1	TM0	x	x

PD : Power_down (PD = 1 : standby mode and reset)

D0-D9 setting method

Current setting code	D9	D8	D7	D6	D5	D4	D3	D2	D1	D0	Output current (mA) (design value)
0	0	0	0	0	0	0	0	0	0	0	0
1	0	0	0	0	0	0	0	0	0	1	0.147
2	0	0	0	0	0	0	0	0	1	0	0.293
3	0	0	0	0	0	0	0	0	1	1	0.586
1021	1	1	1	1	1	1	1	1	0	1	149.70
1022	1	1	1	1	1	1	1	1	1	0	149.85
1023	1	1	1	1	1	1	1	1	1	1	150

Current slope function operation image chart

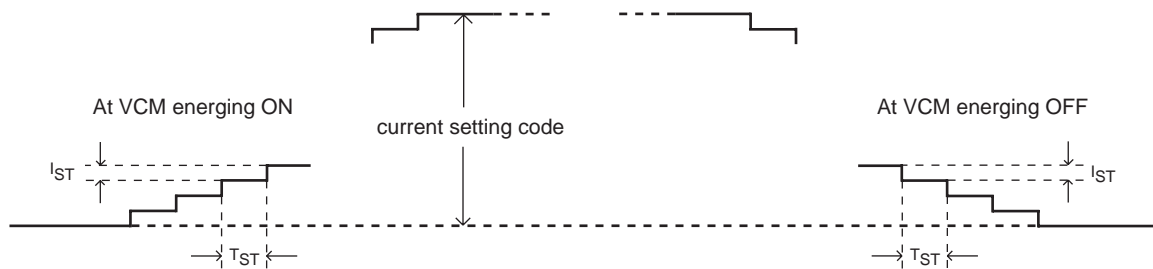

LV8498CT

		TIM							
STP		000	001	010	011	100	101	110	111
000		At current slope OFF							
001		0.032	0.064	0.128	0.256	0.512	1.024	2.048	4.096
		0.147	0.147	0.147	0.147	0.147	0.147	0.147	0.147
010		0.064	0.128	0.256	0.512	1.024	2.048	4.096	8.192
		0.293	0.293	0.293	0.293	0.293	0.293	0.293	0.293
011		0.128	0.256	0.512	1.024	2.048	4.096	8.192	16.38
		0.586	0.586	0.586	0.586	0.586	0.586	0.586	0.586
100		0.256	0.512	1.024	2.048	4.096	8.192	16.38	32.77
		1.173	1.173	1.173	1.173	1.173	1.173	1.173	1.173
101		0.512	1.024	2.048	4.096	8.192	16.38	32.77	65.54
		2.346	2.346	2.346	2.346	2.346	2.346	2.346	2.346
110		1.024	2.048	4.096	8.192	16.38	32.77	65.54	131.08
		4.692	4.692	4.692	4.692	4.692	4.692	4.692	4.692
111		2.048	4.096	8.192	16.38	32.77	65.54	131.08	262.16
		9.383	9.383	9.383	9.383	9.383	9.383	9.383	9.383
FULL_CODE Sweep time		32.7	65.5	130.9	261.9	523.8	1047.6	2095.1	4190.2

In the upper row in the above table each column, the lower is a current step value (I_{ST} :mA), at the step time (T_{ST} :msec).

Relationship between the ENA pin input, I²C input data PD, and current setting 0 (code 0)

This IC supports the following three modes of setting up the standby mode :

- 1) Setting the ENA pin low.
- 2) Setting the PD bit to 1 (high) with I²C input data.
- 3) Setting the output current to 0 with I²C input data.

Execution of one of the steps 1) to 3) causes the output current to 0 and stops operation of the circuit.

When the ENA pin is set low, the I²C data register is reset and the IC is reset to its default state (PD bit set to 0 and output current setting to code 0).

When the ENA pin is to be used with pull_up to VCC, it is necessary to send code 0 once after VCC ON.

ON Semiconductor and the ON logo are registered trademarks of Semiconductor Components Industries, LLC (SCILLC). SCILLC owns the rights to a number of patents, trademarks, copyrights, trade secrets, and other intellectual property. A listing of SCILLC's product/patent coverage may be accessed at www.onsemi.com/site/pdf/Patent-Marking.pdf. SCILLC reserves the right to make changes without further notice to any products herein. SCILLC makes no warranty, representation or guarantee regarding the suitability of its products for any particular purpose, nor does SCILLC assume any liability arising out of the application or use of any product or circuit, and specifically disclaims any and all liability, including without limitation special, consequential or incidental damages. "Typical" parameters which may be provided in SCILLC data sheets and/or specifications can and do vary in different applications and actual performance may vary over time. All operating parameters, including "Typicals" must be validated for each customer application by customer's technical experts. SCILLC does not convey any license under its patent rights nor the rights of others. SCILLC products are not designed, intended, or authorized for use as components in systems intended for surgical implant into the body, or other applications intended to support or sustain life, or for any other application in which the failure of the SCILLC product could create a situation where personal injury or death may occur. Should Buyer purchase or use SCILLC products for any such unintended or unauthorized application, Buyer shall indemnify and hold SCILLC and its officers, employees, subsidiaries, affiliates, and distributors harmless against all claims, costs, damages, and expenses, and reasonable attorney fees arising out of, directly or indirectly, any claim of personal injury or death associated with such unintended or unauthorized use, even if such claim alleges that SCILLC was negligent regarding the design or manufacture of the part. SCILLC is an Equal Opportunity/Affirmative Action Employer. This literature is subject to all applicable copyright laws and is not for resale in any manner.

X-ON Electronics

Largest Supplier of Electrical and Electronic Components

Click to view similar products for [Power Management IC Development Tools](#) *category:*

Click to view products by [ON Semiconductor](#) *manufacturer:*

Other Similar products are found below :

[EVAL-ADM1168LQEBZ](#) [EVB-EP5348UI](#) [MIC23451-AAAYFL EV](#) [MIC5281YMME EV](#) [DA9063-EVAL](#) [ADP122-3.3-EVALZ](#) [ADP130-0.8-EVALZ](#) [ADP130-1.2-EVALZ](#) [ADP130-1.5-EVALZ](#) [ADP130-1.8-EVALZ](#) [ADP1712-3.3-EVALZ](#) [ADP1714-3.3-EVALZ](#) [ADP1715-3.3-EVALZ](#) [ADP1716-2.5-EVALZ](#) [ADP1740-1.5-EVALZ](#) [ADP1752-1.5-EVALZ](#) [ADP1828LC-EVALZ](#) [ADP1870-0.3-EVALZ](#) [ADP1871-0.6-EVALZ](#) [ADP1873-0.6-EVALZ](#) [ADP1874-0.3-EVALZ](#) [ADP1882-1.0-EVALZ](#) [ADP199CB-EVALZ](#) [ADP2102-1.25-EVALZ](#) [ADP2102-1.875EVALZ](#) [ADP2102-1.8-EVALZ](#) [ADP2102-2-EVALZ](#) [ADP2102-3-EVALZ](#) [ADP2102-4-EVALZ](#) [ADP2106-1.8-EVALZ](#) [ADP2147CB-110EVALZ](#) [AS3606-DB](#) [BQ24010EVM](#) [BQ24075TEVM](#) [BQ24155EVM](#) [BQ24157EVM-697](#) [BQ24160EVM-742](#) [BQ24296MEVM-655](#) [BQ25010EVM](#) [BQ3055EVM](#) [NCV891330PD50GEVB](#) [ISLUSBI2CKIT1Z](#) [LM2744EVAL](#) [LM2854EVAL](#) [LM3658SD-AEV/NOPB](#) [LM3658SDEV/NOPB](#) [LM3691TL-1.8EV/NOPB](#) [LM4510SDEV/NOPB](#) [LM5033SD-EVAL](#) [LP38512TS-1.8EV](#)