



ON Semiconductor®

<http://onsemi.com>

LV8711T

Bi-CMOS LSI

PWM Constant-Current Control Stepping Motor Driver

Overview

The LV8711T is a PWM constant-current control stepping motor driver.

Features

- Two circuits of PWM constant-current control H-bridge drivers incorporated
- Control of the stepping motor to 1-2 phase excitations possible
- Reference voltage output: 1.0V
- Short circuit protection circuit incorporated
- Abnormal condition warning output pin incorporated
- Upper and lower regenerative diodes incorporated
- Thermal shutdown circuit incorporated

Specifications

Absolute Maximum Ratings at $T_a = 25^\circ\text{C}$

Parameter	Symbol	Conditions	Ratings	Unit
Motor supply voltage	V_M max		18	V
Logic supply voltage	V_{CC} max		6	V
Logic input voltage	V_{IN}		6	V
Output peak current	I_O peak	Per ch, $t_w \leq 10\text{ms}$, duty 20%	1.0	A
Output continuous current	I_O max	Per ch	800	mA
Allowable power dissipation	P_d max	*	1.45	W
Operating temperature	T_{opr}		-20 to +85	$^\circ\text{C}$
Storage temperature	T_{stg}		-55 to +150	$^\circ\text{C}$

* Specified circuit board : 57.0mm×57.0mm×1.7mm, glass epoxy printed circuit board.

Stresses exceeding Maximum Ratings may damage the device. Maximum Ratings are stress ratings only. Functional operation above the Recommended Operating Conditions is not implied. Extended exposure to stresses above the Recommended Operating Conditions may affect device reliability.

LV8711T

Recommended Operating Ratings at Ta = 25°C

Parameter	Symbol	Conditions	Ratings	Unit
Motor supply voltage range	VM		4 to 16	V
Logic supply voltage range	V _{CC}		2.7 to 5.5	V
Logic input voltage range	V _{IN}		-0.3 to V _{CC} +0.3	V
VREF input voltage range	VREF		0 to V _{CC} -1.8	V

Electrical Characteristics at Ta = 25°C, VM = 12V, V_{CC} = 3.3, VREF = 1.0V

Parameter	Symbol	Conditions	Ratings			Unit
			min	typ	max	
General						
Standby mode current drain	IMstn	PS = "L", no load			1	μA
	I _{CC} stn	PS = "L", no load			1	μA
Current drain	IM	PS = "H", no load		1.0	1.5	mA
	I _{CC}	PS = "H", no load		1.7	3.0	mA
Thermal shutdown temperature	TSD	Design guarantee	150	180		°C
Thermal hysteresis width	ΔTSD	Design guarantee		40		°C
V _{CC} low voltage cutting voltage	V _{th} V _{CC}		2.1	2.4	2.7	V
Low voltage hysteresis voltage	V _{th} HYS		100	130	160	mV
Reference voltage						
REG5 output voltage	VREG5		4.5	5	5.5	V
Output						
Output on resistance	R _{on} U	I _O = -800mA, Source-side		0.78	1.0	Ω
	R _{on} D	I _O = 800mA, Sink-side		0.32	0.43	Ω
Output leakage current	I _O leak	V _O = 15V			10	μA
Diode forward voltage	VD	ID = -800mA		1.0	1.2	V
Logic input						
Logic pin input current	I _{IN} L	V _{IN} = 0.8V	4	8	12	μA
	I _{IN} H	V _{IN} = 3.3V	22	33	45	μA
Logic high-level input voltage	V _{INH}		2.0			V
Logic low-level input voltage	V _{INL}				0.8	V
Constant-current control						
REG1 output voltage	VREG1		0.95	1.0	1.05	V
VREF input current	I _{REF}	VREF = 1.0V	-0.5			μA
Current setting reference voltage	V _{tatt} 00	VREF = 1.0V	0.192	0.200	0.208	V
	V _{tatt} 01	VREF = 1.0V	0.152	0.160	0.168	V
	V _{tatt} 10	VREF = 1.0V	0.092	0.100	0.108	V
	V _{tatt} 11	VREF = 1.0V	0.032	0.040	0.048	V
Chopping frequency	F _{chop}	C _{chop} = 220pF	36	45	54	kHz
CHOP pin threshold voltage	V _{CHOP} H		0.6	0.7	0.8	V
	V _{CHOP} L		0.17	0.2	0.23	V
CHOP pin charge/discharge current	I _{chop}		7	10	13	μA
Output short-circuit protection						
EMO pin saturation voltage	V _{sat} EMO	I _{EMO} = 1mA		250	400	mV

LV8711T

Package Dimensions

unit : mm (typ)

3260A

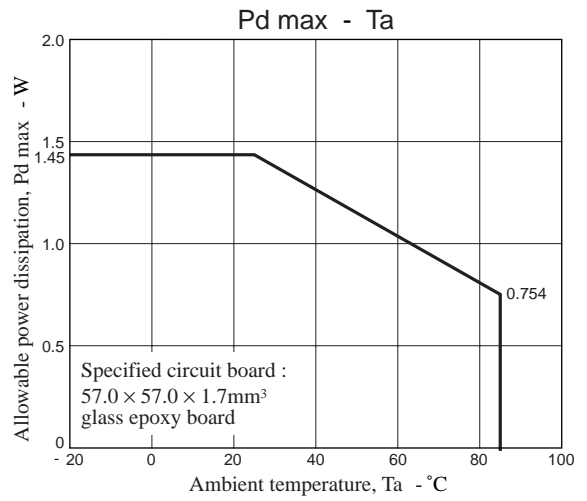
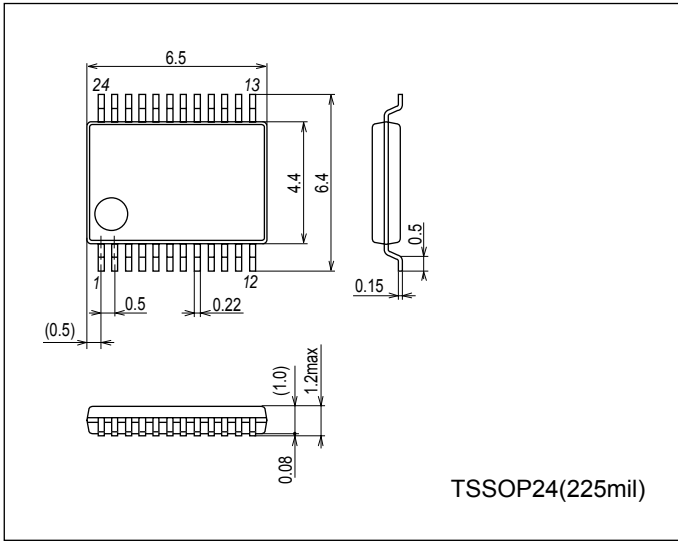

Pin Assignment

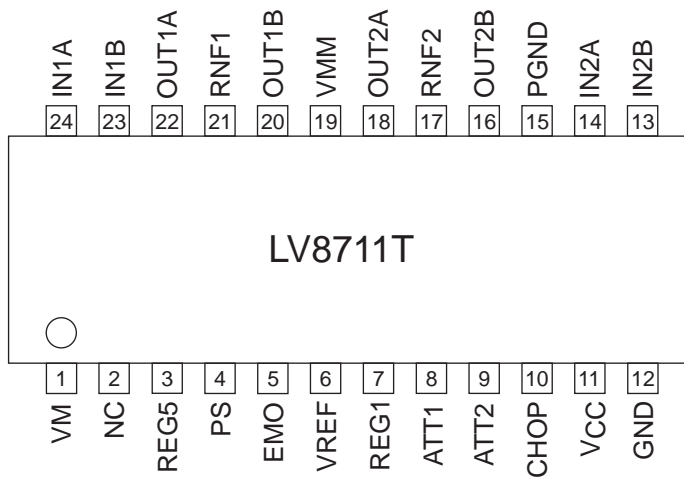

Block Diagram

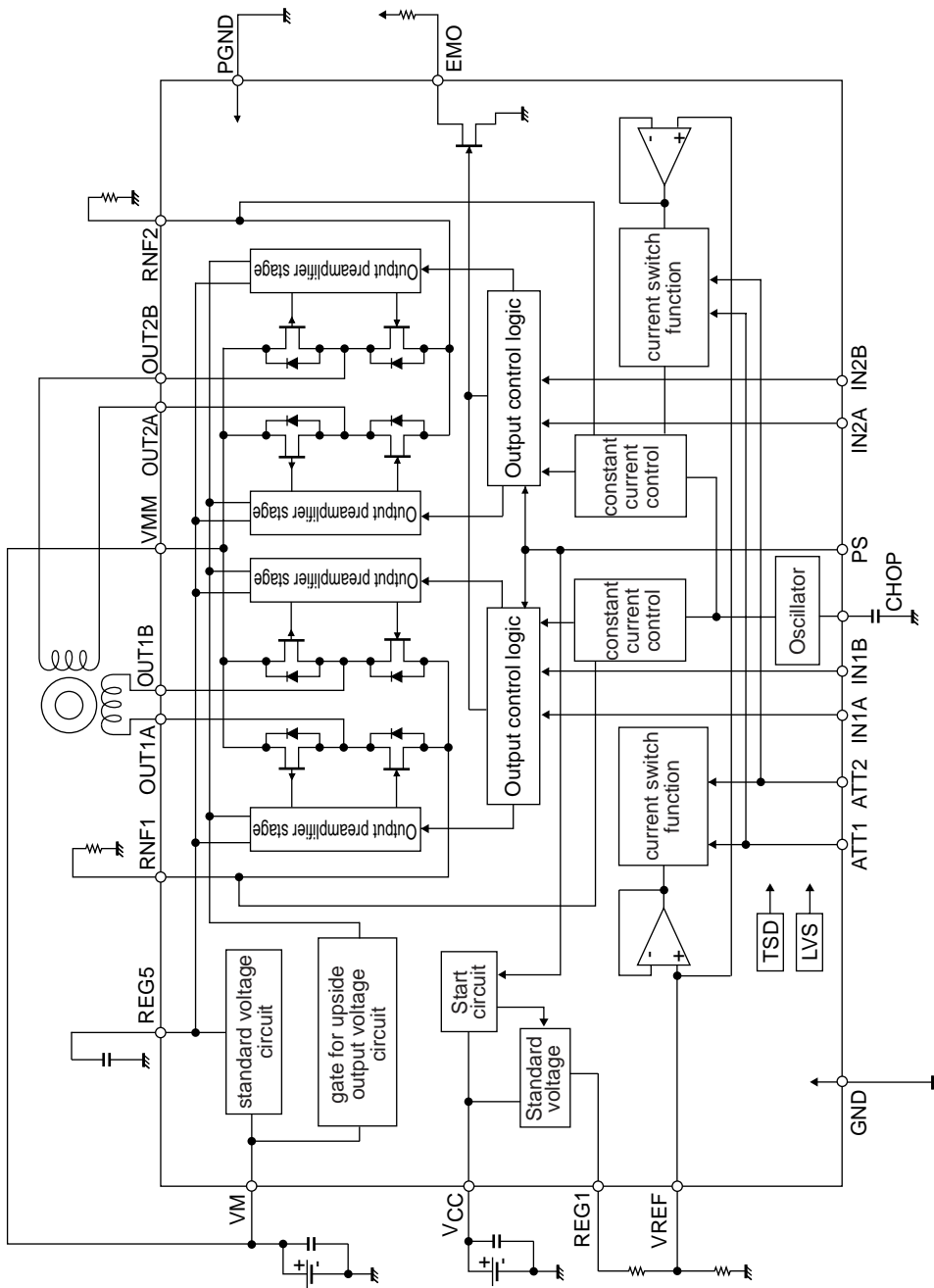

LV8711T

Pin Functions

Pin No.	Pin Name	Pin Function	Equivalent Circuit
8 9 13 14 23 24	ATT1 ATT2 IN2B IN2A IN1B IN1A	Energization current switching pin 1. Energization current switching pin 2. Channel 2 driver output control input pin. Channel 2 driver output control input pin. Channel 1 driver output control input pin. Channel 1 driver output control input pin.	
4	PS	Enable input pin.	
16 17 18 20 21 22	OUT2B RNF2 OUT2A OUT1B RNF1 OUT1A	Channel 2 OUTB output pin. Channel 2 current sensing resistor connection pin. Channel 2 OUTA output pin. Channel 1 OUTB output pin. Channel 1 current sensing resistor connection pin. Channel 1 OUTA output pin.	
3	REG5	Internal reference voltage output pin.	

Continued on next page.

LV8711T

Continued from preceding page.

Pin No.	Pin Name	Pin Function	Equivalent Circuit
5	EMO	Abnormal condition warning output pin.	
6	VREF	Channel 1 and 2 current setting reference voltage input pin.	
7	REG1	Current setting reference voltage output pin.	
10	CHOP	Chopping frequency setting capacitor connection pin.	

Input pin function

(1) Chip enable function

Standby mode / operating mode of the IC are switched by setting the PS pin. In the standby-state, the IC enters a power saving mode and all logic is reset. In the standby-state, internal regulator circuit is not operative.

PS	Condition	Internal regulator
Low or Open	Standby mode	Standby
High	Operating mode	Operating

(2) STM output control logic

Parallel input		Output		Current direction
IN1A(2A)	IN1B(2B)	OUT1A(2A)	OUT1B(2B)	
Low	Low	OFF	OFF	Output OFF
High	Low	High	Low	OUTA to OUTB
Low	High	Low	High	OUTB to OUTA
High	High	Low	Low	Brake(DCM mode)

(3) Constant-current setting

The constant-current control setting consist of the VREF voltage setting and resistor (RNF) connected between RNF and ground. The current is set according to the following equation.

$$I_{OUT} [A] = VREF [V] / 5 / RNF [\Omega]$$

Also, the voltage applied to the VREF pin can be switched to four stages settings by the state of two inputs of the ATT1 and ATT2 pins. This function is effective for power saving when the motor holding current is applied.

Attenuation function of the VREF input voltage

ATT1	ATT2	Current setting reference voltage attenuation ratio
Low	Low	100%
High	Low	80%
Low	High	50%
High	High	20%

The output current calculation method for using of attenuation function of the VREF input voltage is as below.

$$I_{OUT} = (VREF / 5) \times \text{Attenuation ratio} / RNF \text{ resistance}$$

e.g. When the VREF is 1.0V and the set reference voltage is 100% [(ATT1, ATT2) = (Low, Low)] and the RNF resistance is 0.47Ω, the following output current is set.

$$I_{OUT} = 1.0V / 5 \times 100\% / 0.47\Omega = 425mA$$

In this conditions, when (ATT1, ATT2) is set to (High, High),

$$I_{OUT} = 425mA \times 20\% = 85mA$$

Therefore, the power saving is executable by attenuation of the output current when motor holding current is supplied.

(4) Setting the chopping frequency

For constant-current control, chopping operation is made with the frequency determined by the external capacitor (connected to the CHOP pin). The chopping frequency to be set with the capacitor connected to the CHOP pin (pin 10) is as shown below.

Chopping period: T _{chop}	$T_{chop} \approx C \times V \times 2 / I$ [s]
	V: Threshold voltage Typ. 0.5V
	I: Charge / discharge current Typ. 10μA
Chopping frequency: F _{chop}	$F_{chop} \approx 1 / T_{chop}$ [Hz]

(5) Constant-current control time chart (chopping operate)

In each current mode, the operation sequence is as described below:

- At first of chopping cycle, the IC goes to CHARGE mode. (The Blanking section in which the CHARGE mode is forced regardless of the magnitudes of the coil current (I_{COIL}) and the set current (I_{REF}) exists for $1\mu s$.)
- In Blanking section, the IC compares the coil current (I_{COIL}) and the set current (I_{REF}).
If the $I_{COIL} < I_{REF}$ state is existent in Blanking section.

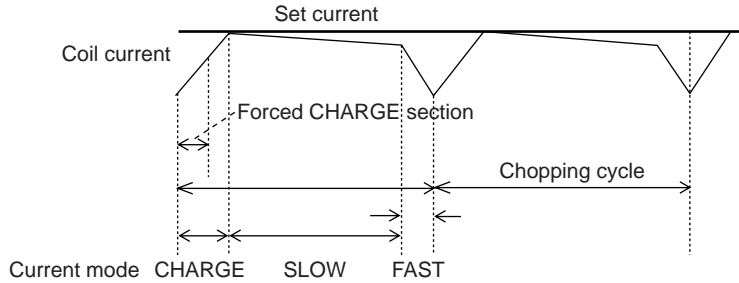

Charge mode continues until $I_{COIL} \geq I_{REF}$. After that the IC switches to SLOW DECAY mode and then switches to FAST DECAY mode for the last about $1\mu s$.

If the $I_{COIL} < I_{REF}$ state is non-existent in Blanking section.

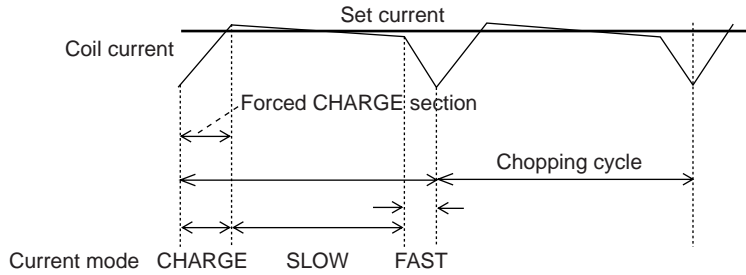

The IC switches to SLOW DECAY after Blanking section, and then switches to FAST DECAY mode for the last about $1\mu s$.

The IC repeats the above operation.

LV8711T

(6) Typical current waveform in each excitation mode

6-1) STM Drive mode

Two-phase excitation (CW mode)

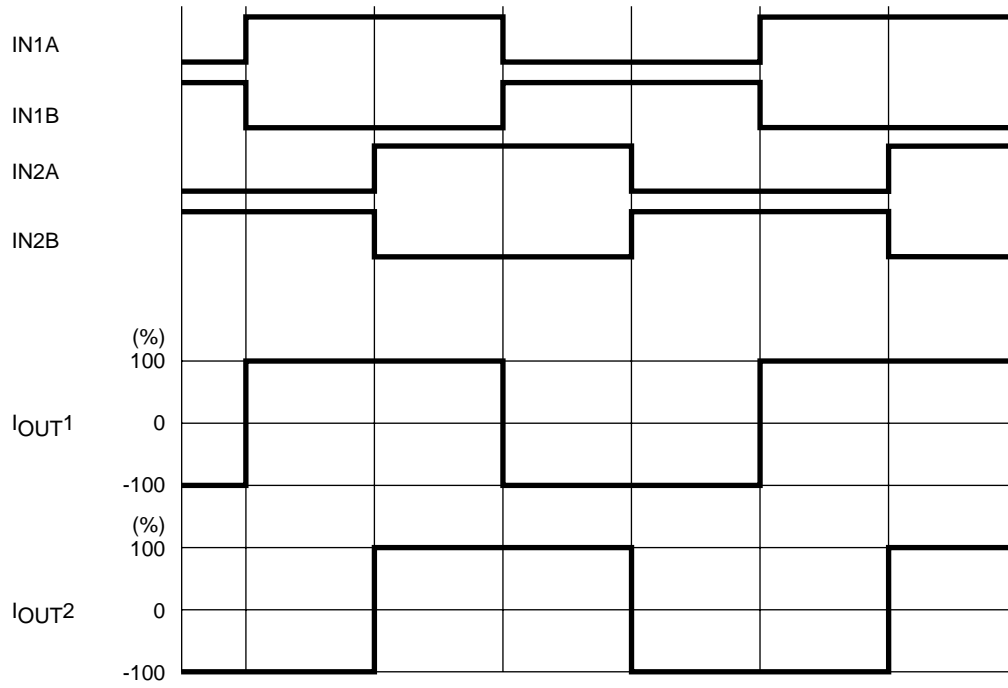

1-2 phase excitation (CW mode)

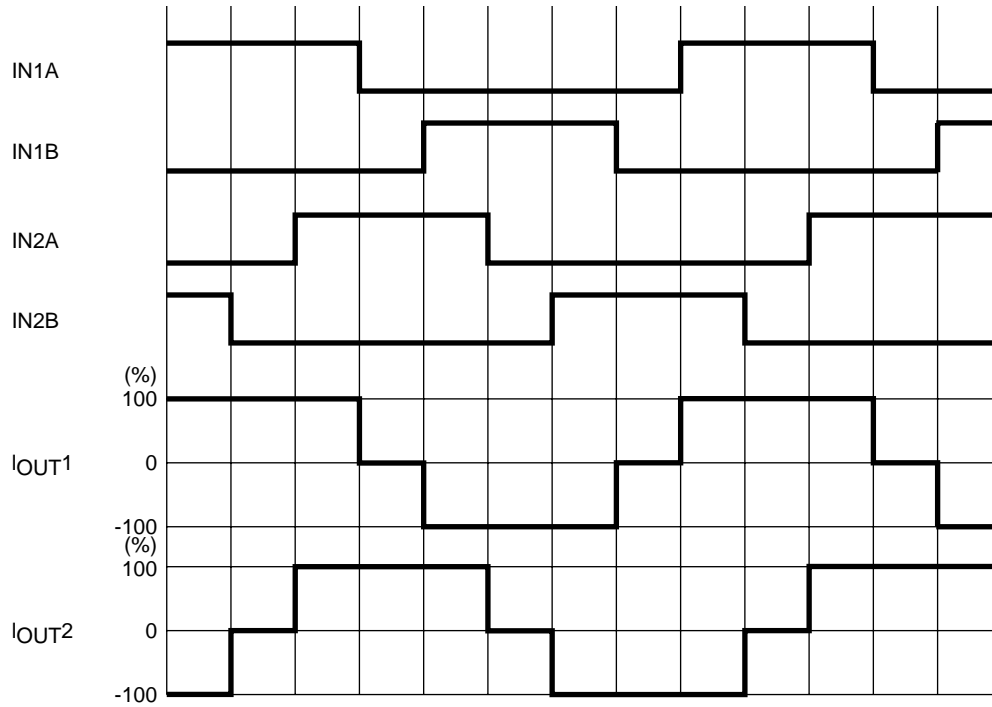

6-2) DCM Drive mode

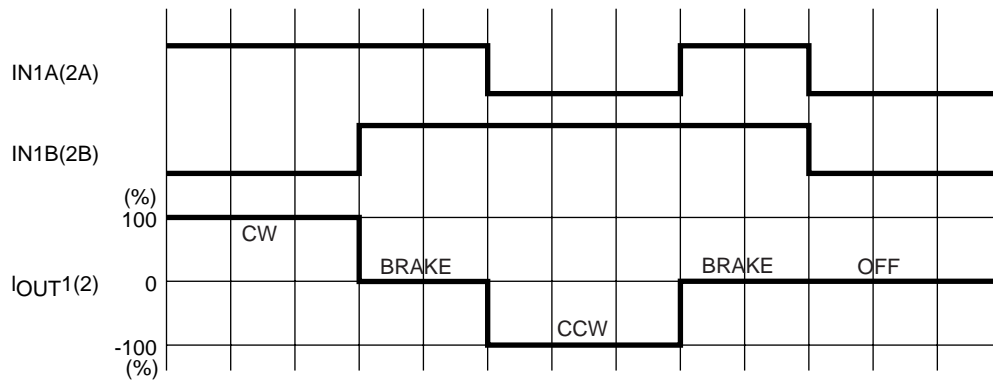

(7) Output short-circuit protection

To protect IC from damage due to short-circuit of the output caused by lightning or ground fault, the output short-circuit protection circuit to put the output in the OFF mode is incorporated.

7-1) Protective function operation (Latch method)

When detecting the output short-circuit state, the short-circuit protection circuit is activated.

When short-circuit state is detected $\approx 4\mu\text{s}$ (count by the internal timer), detected output is OFF at the time.

Then, when the output exceeds the timer latch time counted by the internal counter, the output is ON. Still, the short circuit state is detected, the IC switches all output to stand-by mode and keep the state.

This state is released by setting PS = Low

(8) Abnormal condition warning output pin

EMO, warning output pin of thermal shutdown circuit and the output short-circuit protection circuit, is an open-drain output. EMO outputs ON when output short-circuit is detected.

When detecting the output overdrive, the EMO outputs ON. If the junction temperature goes down at the time, EMO outputs OFF automatically.

(9) Recommended power-on sequence

Provide a wait time of $10\mu\text{s}$ or more after V_{CC} power supply rises before supplying VM power supply.

Provide a wait time of $10\mu\text{s}$ or more after VM power supply rises before setting the PS pin High.

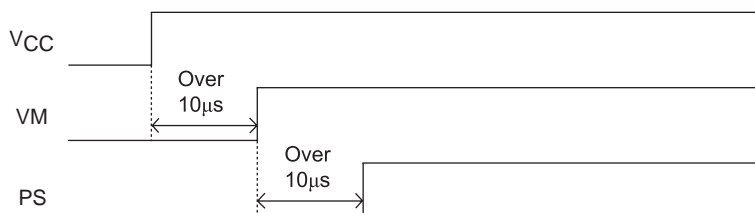

The above power-on sequence is only a recommendation, and there are no risks of damage or over current to the IC even if this sequence is not followed.

Application Circuit Example

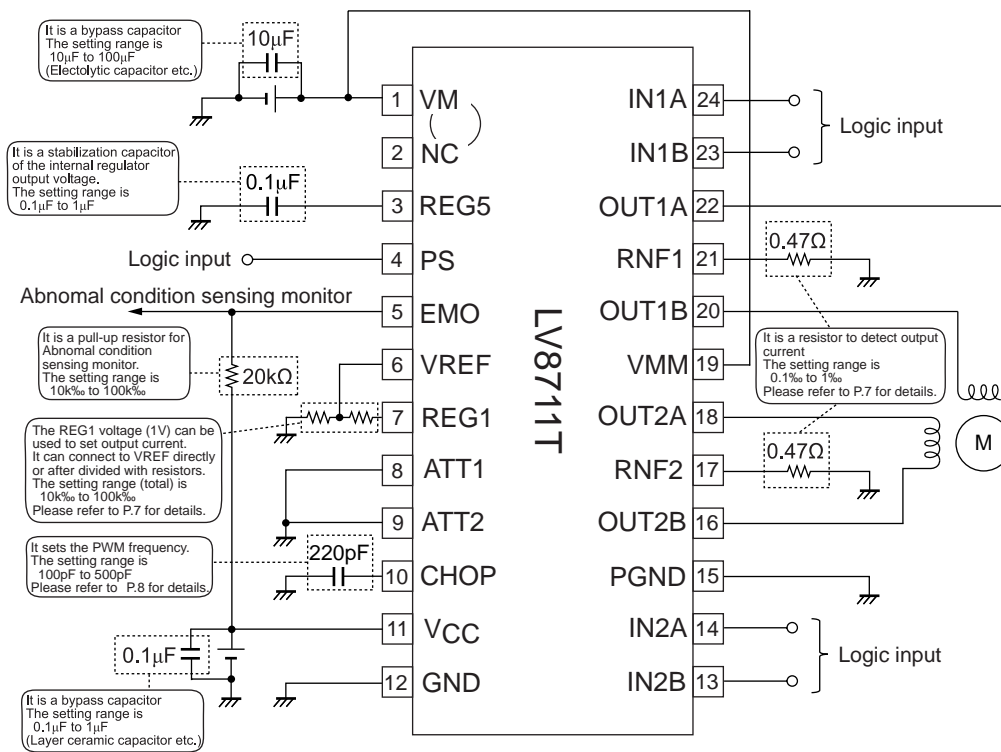

Each constant setting method for the above circuit diagram example is as follows :

Current LIMIT (100%) set

$$VREF = 1.0V \text{ (when internal regulator output is connected)}$$

$$I_{LIMIT} = VREF / 5 / RNF \text{ resistance}$$

$$= 1.0V / 5 / 0.47\Omega = 425mA$$

Chopping frequency setting

$$F_{chop} = I_{chop} / (C_{chop} \times V_t \times 2)$$

$$= 10\mu A / (220pF \times 0.5V \times 2) = 45 \text{ kHz}$$

ON Semiconductor and the ON logo are registered trademarks of Semiconductor Components Industries, LLC (SCILLC). SCILLC owns the rights to a number of patents, trademarks, copyrights, trade secrets, and other intellectual property. A listing of SCILLC's product/patent coverage may be accessed at www.onsemi.com/site/pdf/Patent-Marking.pdf. SCILLC reserves the right to make changes without further notice to any products herein. SCILLC makes no warranty, representation or guarantee regarding the suitability of its products for any particular purpose, nor does SCILLC assume any liability arising out of the application or use of any product or circuit, and specifically disclaims any and all liability, including without limitation special, consequential or incidental damages. "Typical" parameters which may be provided in SCILLC data sheets and/or specifications can and do vary in different applications and actual performance may vary over time. All operating parameters, including "Typicals" must be validated for each customer application by customer's technical experts. SCILLC does not convey any license under its patent rights nor the rights of others. SCILLC products are not designed, intended, or authorized for use as components in systems intended for surgical implant into the body, or other applications intended to support or sustain life, or for any other application in which the failure of the SCILLC product could create a situation where personal injury or death may occur. Should Buyer purchase or use SCILLC products for any such unintended or unauthorized application, Buyer shall indemnify and hold SCILLC and its officers, employees, subsidiaries, affiliates, and distributors harmless against all claims, costs, damages, and expenses, and reasonable attorney fees arising out of, directly or indirectly, any claim of personal injury or death associated with such unintended or unauthorized use, even if such claim alleges that SCILLC was negligent regarding the design or manufacture of the part. SCILLC is an Equal Opportunity/Affirmative Action Employer. This literature is subject to all applicable copyright laws and is not for resale in any manner.

X-ON Electronics

Largest Supplier of Electrical and Electronic Components

Click to view similar products for [Power Management IC Development Tools](#) *category:*

Click to view products by [ON Semiconductor](#) *manufacturer:*

Other Similar products are found below :

[EVAL-ADM1168LQEBZ](#) [EVB-EP5348UI](#) [MIC23451-AAAYFL EV](#) [MIC5281YMME EV](#) [DA9063-EVAL](#) [ADP122-3.3-EVALZ](#) [ADP130-0.8-EVALZ](#) [ADP130-1.2-EVALZ](#) [ADP130-1.5-EVALZ](#) [ADP130-1.8-EVALZ](#) [ADP1712-3.3-EVALZ](#) [ADP1714-3.3-EVALZ](#) [ADP1715-3.3-EVALZ](#) [ADP1716-2.5-EVALZ](#) [ADP1740-1.5-EVALZ](#) [ADP1752-1.5-EVALZ](#) [ADP1828LC-EVALZ](#) [ADP1870-0.3-EVALZ](#) [ADP1871-0.6-EVALZ](#) [ADP1873-0.6-EVALZ](#) [ADP1874-0.3-EVALZ](#) [ADP1882-1.0-EVALZ](#) [ADP199CB-EVALZ](#) [ADP2102-1.25-EVALZ](#) [ADP2102-1.875EVALZ](#) [ADP2102-1.8-EVALZ](#) [ADP2102-2-EVALZ](#) [ADP2102-3-EVALZ](#) [ADP2102-4-EVALZ](#) [ADP2106-1.8-EVALZ](#) [ADP2147CB-110EVALZ](#) [AS3606-DB](#) [BQ24010EVM](#) [BQ24075TEVM](#) [BQ24155EVM](#) [BQ24157EVM-697](#) [BQ24160EVM-742](#) [BQ24296MEVM-655](#) [BQ25010EVM](#) [BQ3055EVM](#) [NCV891330PD50GEVB](#) [ISLUSBI2CKIT1Z](#) [LM2744EVAL](#) [LM2854EVAL](#) [LM3658SD-AEV/NOPB](#) [LM3658SDEV/NOPB](#) [LM3691TL-1.8EV/NOPB](#) [LM4510SDEV/NOPB](#) [LM5033SD-EVAL](#) [LP38512TS-1.8EV](#)