



ON Semiconductor®

<http://onsemi.com>

LV8729V

Bi-CMOS IC

PWM Constant-Current Control Stepper Motor Driver

Overview

The LV8729V is a PWM current-controlled microstep bipolar stepper motor driver.

This driver can perform eight times of excitation of the second phase to 32W1-second phase and can drive simply by the CLK input.

Function

- Single-channel PWM current control stepper motor driver.
- BiCDMOS process IC.
- Output on-resistance (upper side : 0.35Ω ; lower side : 0.3Ω ; total of upper and lower : 0.65Ω ; Ta = 25°C, I_O = 1.8A)
- 2-phase, 1-2 phase, W1-2 phase, 2W1-2 phase, 4W1-2 phase, 8W1-2 phase, 16W1-2 phase, 32W1-2 phase excitation are selectable.
- Advance the excitation step with the only step signal input.
- Available forward reverse control.
- Over current protection circuit.
- Thermal shutdown circuit.
- Input pull down resistance
- With reset pin and enable pin.

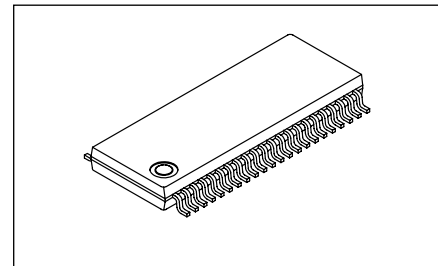

SSOP44K (275mil)

Specifications

Absolute Maximum Ratings at Ta = 25°C

Parameter	Symbol	Conditions	Ratings	Unit
Maximum supply voltage	V _M max	V _M , V _{M1} , V _{M2}	36	V
Maximum output current	I _O max	Per 1ch	1.8	A
Maximum logic input voltage	V _{IN} max	ST , MD1 , MD2 , MD3 , OE , RST , FR ,	6	V
Maximum VREF input voltage	VREF max		6	V
Maximum MO input voltage	V _{MO} max		6	V
Maximum DOWN input voltage	V _{DOWN} max		6	V
Allowable power dissipation	P _d max	*	3.85	W
Operating temperature	T _{opr}		-30 to +85	°C
Storage temperature	T _{stg}		-55 to +150	°C

* Specified circuit board : 90.0mm×90.0mm×1.6mm, glass epoxy 2-layer board, with backside mounting.

Caution 1) Absolute maximum ratings represent the value which cannot be exceeded for any length of time.

Caution 2) Even when the device is used within the range of absolute maximum ratings, as a result of continuous usage under high temperature, high current, high voltage, or drastic temperature change, the reliability of the IC may be degraded. Please contact us for the further details.

Stresses exceeding those listed in the Maximum Ratings table may damage the device. If any of these limits are exceeded, device functionality should not be assumed, damage may occur and reliability may be affected.

ORDERING INFORMATION

See detailed ordering and shipping information on page 21 of this data sheet.

LV8729V

Allowable Operating Ratings at $T_a = 25^\circ\text{C}$

Parameter	Symbol	Conditions	Ratings	Unit
Supply voltage range	VM	VM, VM1, VM2	9 to 32	V
Logic input voltage	V_{IN}	ST, MD1, MD2, MD3, OE, RST, FR, STEP	0 to 5	V
VREF input voltage range	VREF		0 to 3	V

Functional operation above the stresses listed in the Recommended Operating Ranges is not implied. Extended exposure to stresses beyond the Recommended Operating Ranges limits may affect device reliability.

Electrical Characteristics at $T_a = 25^\circ\text{C}$, VM = 24V, VREF = 1.5V

Parameter		Symbol	Conditions	Ratings			Unit
				min	typ	max	
Standby mode current drain		I_{Mst}	ST = "L", VM+VM1+VM2		70	100	μA
Current drain		IM	ST = "H", OE = "H", no load VM+VM1+VM2		3.3	4.6	mA
Thermal shutdown temperature		TSD	Design guarantee	150	180	200	$^\circ\text{C}$
Thermal hysteresis width		ΔTSD	Design guarantee		40		$^\circ\text{C}$
Logic pin input current		I_{INL}	ST, MD1, MD2, MD3, OE, RST, FR, STEP, $V_{IN} = 0.8\text{V}$	3	8	15	μA
		I_{INH}	ST, MD1, MD2, MD3, OE, RST, FR, STEP, $V_{IN} = 5\text{V}$	30	50	70	μA
Logic input voltage	High	V_{INH}	ST, MD1, MD2, MD3, OE, RST, FR, STEP	2.0		5.0	V
	Low	V_{INL}		0		0.8	V
Chopping frequency		Fch	Cosc1 = 100pF	70	100	130	kHz
OSC1 pin charge/discharge current		Iosc1		7	10	13	μA
Chopping oscillation circuit threshold voltage		Vtup1		0.8	1	1.2	V
		Vtdown1		0.3	0.5	0.7	V
VREF pin input voltage		Iref	VREF = 1.5V	-0.5			μA
DOWN output residual voltagr		V_{O1DOWN}	I _{down} = 1mA		40	100	mV
MO pin residual voltage		V_{O1MO}	I _{mo} = 1mA		40	100	mV
Hold current switching frequency		Fdown	Cosc2 = 1500pF	1.12	1.6	2.08	Hz
Hold current switching frequency threshold voltage		Vtup2		0.8	1	1.2	V
		Vtdown2		0.3	0.5	0.7	V
VREG1 output voltage		Vreg1		4.7	5	5.3	V
VREG2 output voltage		Vreg2	V_M	18	19	20	V
Output on-resistance		Ronu	I _O = 1.8A, high-side ON resistance		0.35	0.455	Ω
		Rond	I _O = 1.8A, low-side ON resistance		0.3	0.39	Ω
Output leakage current		I _{Oleak}	$V_M = 36\text{V}$			50	μA
Diode forward voltage		VD	I _D = -1.8A		1	1.4	V
Current setting reference voltage		VRF	VREF = 1.5V, Current ratio 100%	0.285	0.3	0.315	V

Product parametric performance is indicated in the Electrical Characteristics for the listed test conditions, unless otherwise noted. Product performance may not be indicated by the Electrical Characteristics if operated under different conditions.

LV8729V

Package Dimensions

unit : mm (typ)

SSOP44K (275mil) Exposed Pad
CASE 940AF
ISSUE A

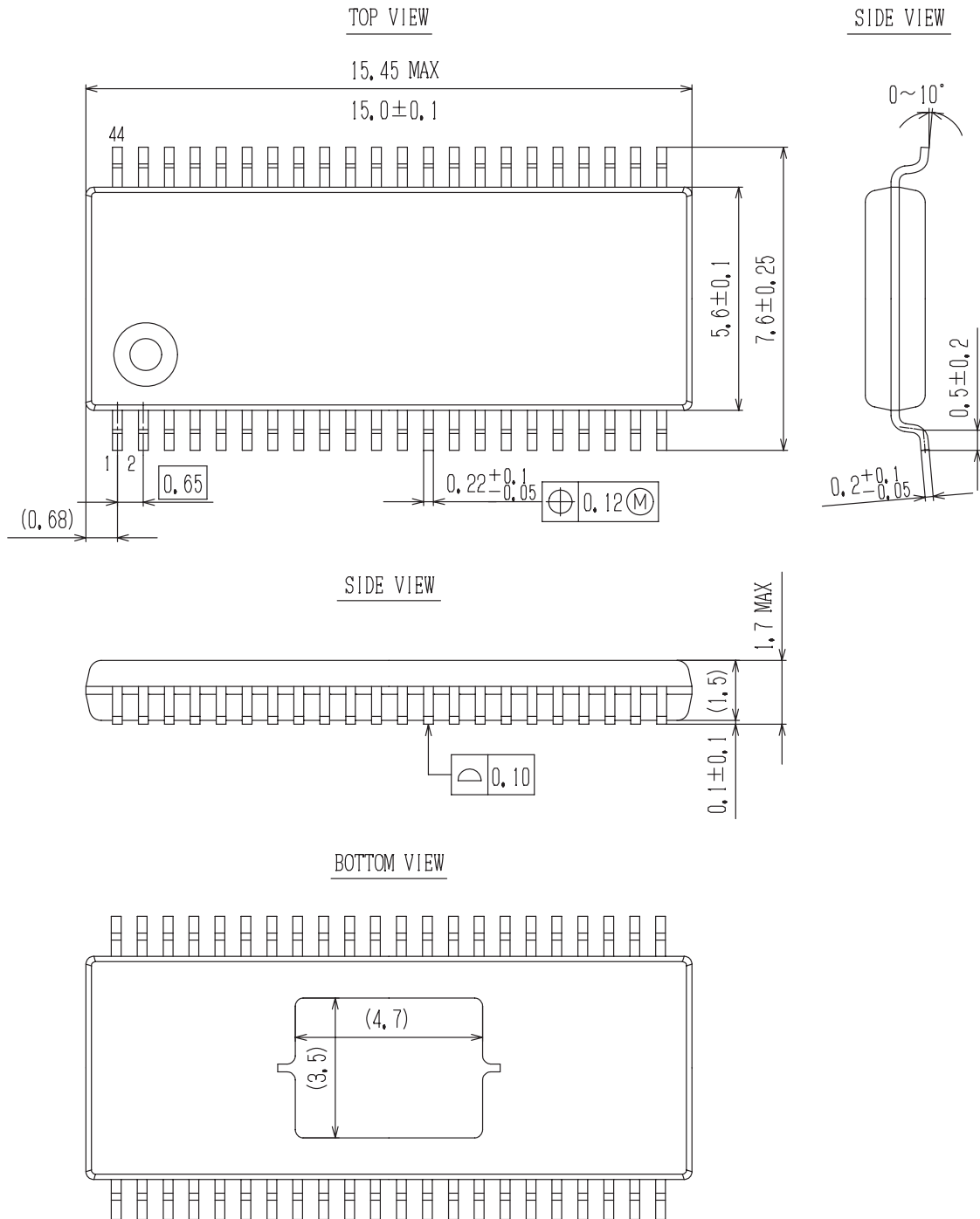

LV8729V

SOLDERING FOOTPRINT*

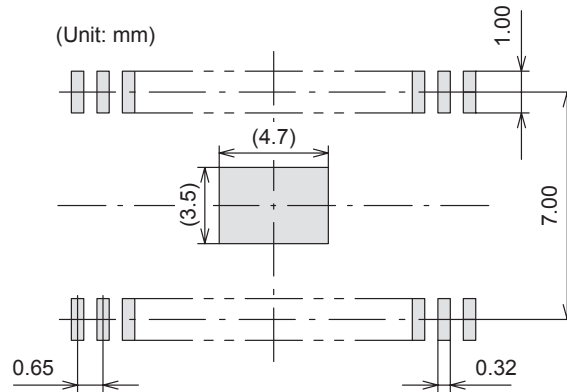

NOTES:

1. The measurements are for reference only, and unable to guarantee.
2. Please take appropriate action to design the actual Exposed Die Pad and Fin portion.
3. After setting, verification on the product must be done.
(Although there are no recommended design for Exposed Die Pad and Fin portion Metal mask and shape for Through-Hole pitch (Pitch & Via etc), checking the soldered joint condition and reliability verification of soldered joint will be needed. Void ■ gradient ■ insufficient thickness of soldered joint or bond degradation could lead IC destruction because thermal conduction to substrate becomes poor.)

*For additional information on our Pb-Free strategy and soldering details, please download the ON Semiconductor Soldering and Mounting Techniques Reference Manual, SOLDERRM/D.

GENERIC MARKING DIAGRAM*

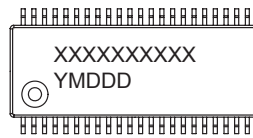

XXXXX = Specific Device Code
Y = Year
M = Month
DDD = Additional Traceability Data

*This information is generic. Please refer to device data sheet for actual part marking. Pb-Free indicator, "G" or microdot "■", may or may not be present.

LV8729V

Pin Assignment

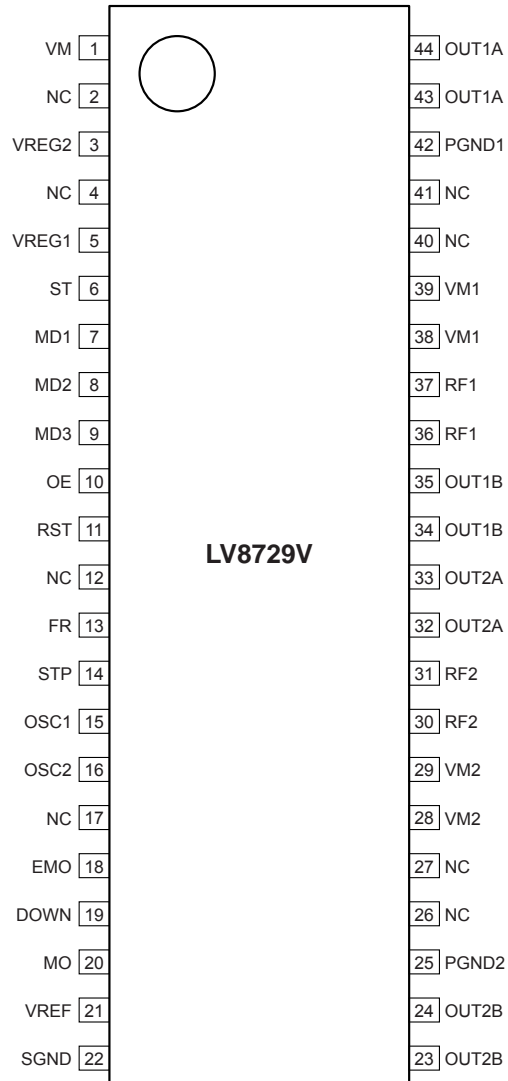

Top view

LV8729V

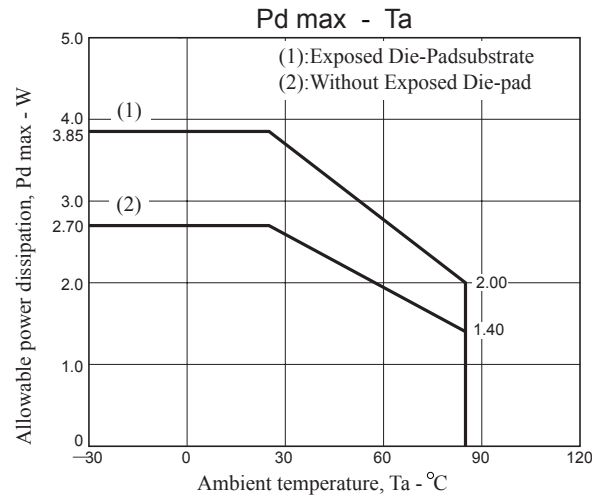

Substrate Specifications (Substrate recommended for operation of LV8729V)

- Size : 90mm × 90mm × 1.6mm (two-layer substrate [2S0P])
Material : Glass epoxy
Copper wiring density : L1 = 85% / L2 = 90%

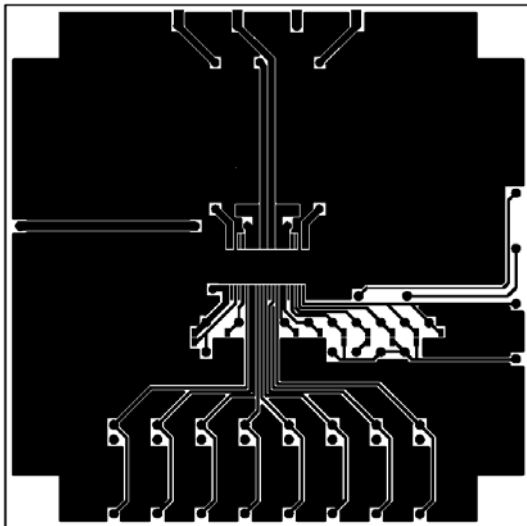

L1 : Copper wiring pattern diagram

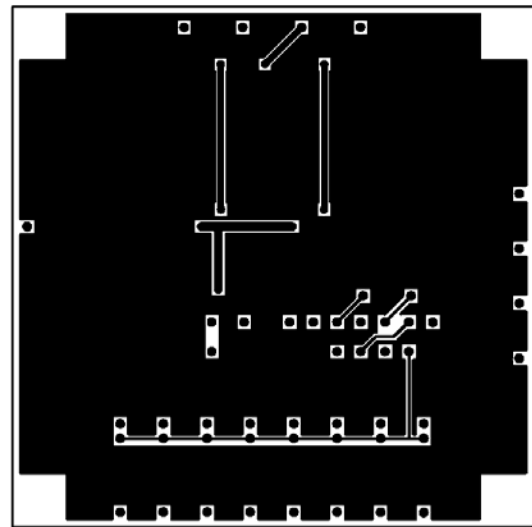

L2 : Copper wiring pattern diagram

Cautions

- 1) The data for the case with the Exposed Die-Pad substrate mounted shows the values when 90% or more of the Exposed Die-Pad is wet.
- 2) For the set design, employ the derating design with sufficient margin.
Stresses to be derated include the voltage, current, junction temperature, power loss, and mechanical stresses such as vibration, impact, and tension.
Accordingly, the design must ensure these stresses to be as low or small as possible.
The guideline for ordinary derating is shown below :
 - (1) Maximum value 80% or less for the voltage rating
 - (2) Maximum value 80% or less for the current rating
 - (3) Maximum value 80% or less for the temperature rating
- 3) After the set design, be sure to verify the design with the actual product.
Confirm the solder joint state and verify also the reliability of solder joint for the Exposed Die-Pad, etc.
Any void or deterioration, if observed in the solder joint of these parts, causes deteriorated thermal conduction, possibly resulting in thermal destruction of IC.

Block Diagram

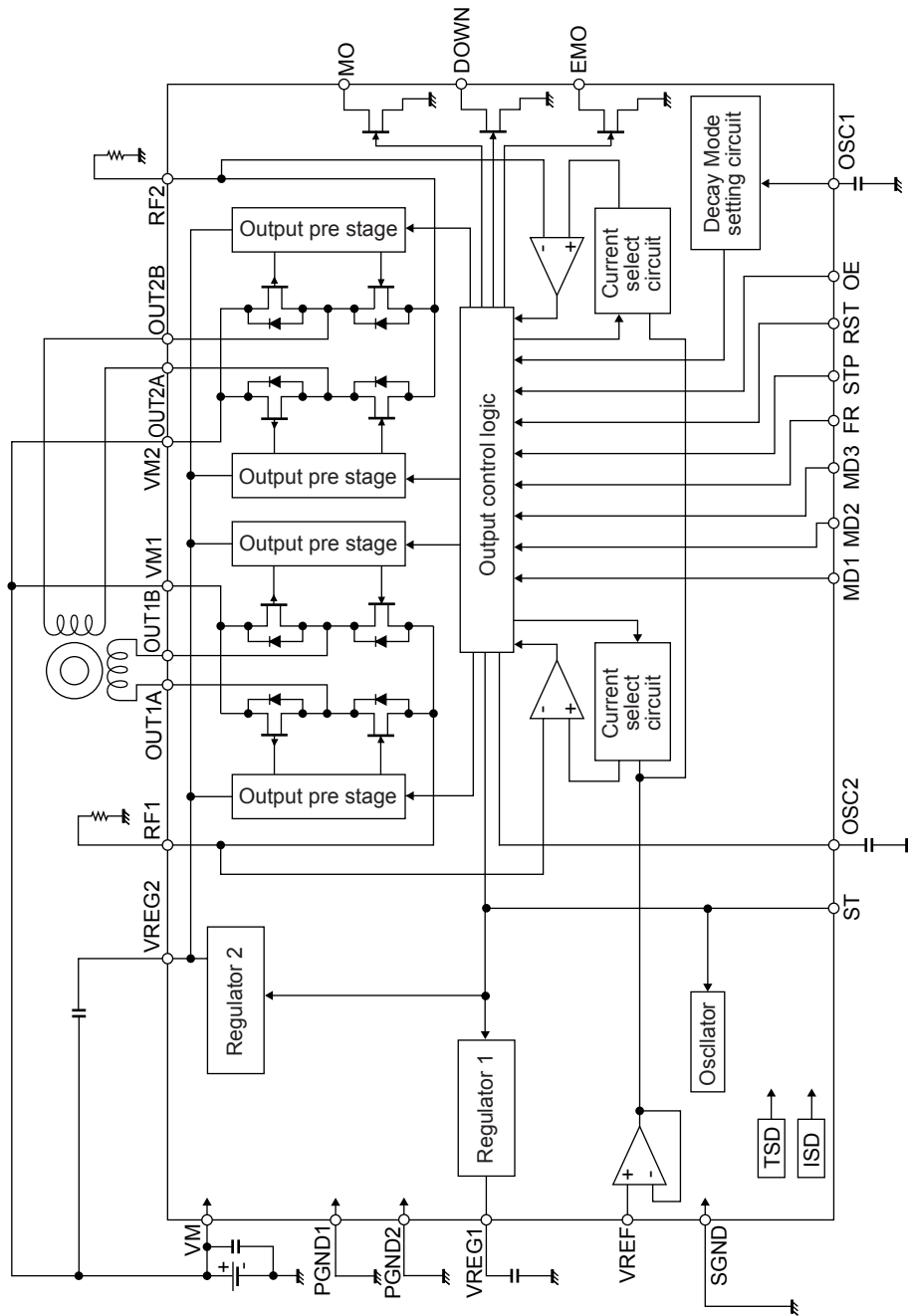

LV8729V

Pin Functions

Pin No.	Pin Name	Pin Function	Equivalent Circuit
7 8 9 10 11 13 14	MD1 MD2 MD3 OE RST FR STP	Excitation mode switching pin Excitation mode switching pin Excitation mode switching pin Output enable signal input pin Reset signal input pin Forward / Reverse signal input pin Step clock pulse signal input pin	
6	ST	Chip enable pin.	
23, 24 25 28, 29 30, 31 32, 33 34, 35 36, 37 38, 39 42 43, 44	OUT2B PGND2 VM2 RF2 OUT2A OUT1B RF1 VM1 PGND1 OUT1A	Channel 2 OUTB output pin. Channel 2 Power system ground Channel 2 motor power supply connection pin. Channel 2 current-sense resistor connection pin. Channel 2 OUTA output pin. Channel 1 OUTB output pin. Channel 1 current-sense resistor connection pin. Channel 1 motor power supply pin. Channel 1 Power system ground Channel 1 OUTA output pin.	
21	VREF	Constant-current control reference voltage input pin.	

Continued on next page.

LV8729V

Continued from preceding page.



Pin No.	Pin Name	Pin Function	Equivalent Circuit
3	VREG2	Internal regulator capacitor connection pin.	
5	VREG1	Internal regulator capacitor connection pin.	
18 19 20	EMO DOWN MO	Over-current detection alarm output pin. Holding current output pin. Position detecting monitor pin.	
15 16	OSC1 OSC2	Copping frequency setting capacitor connection pin. Holding current detection time setting capacitor connection pin.	

Reference describing operation

(1) Stand-by function

When ST pin is at low levels, the IC enters stand-by mode, all logic is reset and output is turned OFF.
 When ST pin is at high levels, the stand-by mode is released.

(2) STEP pin function

Input		Operating mode
ST	STP	
Low	*	Standby mode
High		Excitation step proceeds
High		Excitation step is kept

(3) Input Timing

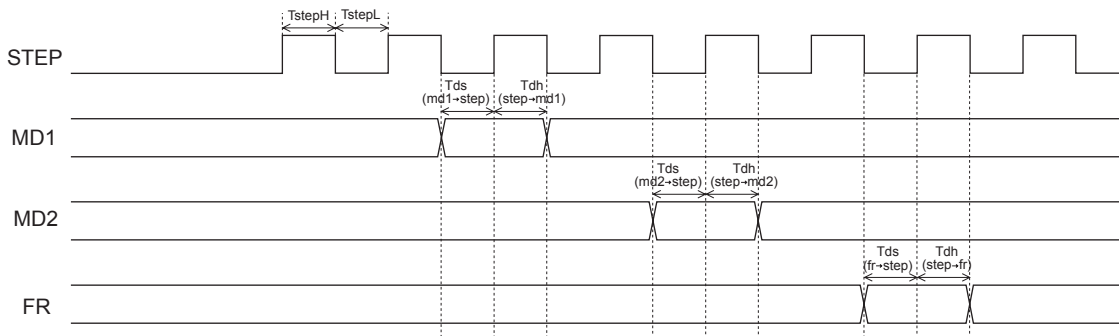

TstepH/TstepL : Clock H/L pulse width (min 500ns)
 Tds : Data set-up time (min 500ns)
 Tdh : Data hold time (min 500ns)

(4) Excitation setting method

Set the excitation setting as shown in the following table by setting MD1 pin, MD2 pin and MD3 pin.

Input			Mode (Excitation)	Initial position	
MD3	MD2	MD1		1ch current	2ch current
Low	Low	Low	2 phase	100%	-100%
Low	Low	High	1-2 phase	100%	0%
Low	High	Low	W1-2 phase	100%	0%
Low	High	High	2W1-2 phase	100%	0%
High	Low	Low	4W1-2 phase	100%	0%
High	Low	High	8W1-2 phase	100%	0%
High	High	Low	16W1-2 phase	100%	0%
High	High	High	32W1-2 phase	100%	0%

The initial position is also the default state at start-up and excitation position at counter-reset in each excitation mode.

(5) Output current setting

Output current is set shown below by the VREF pin (applied voltage) and a resistance value between RF1(2) pin and GND.

$$I_{OUT} = (VREF / 5) / RF1(2) \text{ resistance}$$

* The setting value above is a 100% output current in each excitation mode.

(Example) When VREF = 1.1V and RF1 (2) resistance is 0.22Ω, the setting is shown below.

$$I_{OUT} = (1.1V / 5) / 0.22\Omega = 1.0A$$

(6) Output enable function

When the OE pin is set Low, the output is forced OFF and goes to high impedance. However, the internal logic circuits are operating, so the excitation position proceeds when the STP is input. Therefore, when OE pin is returned to High, the output level conforms to the excitation position proceeded by the STP input.

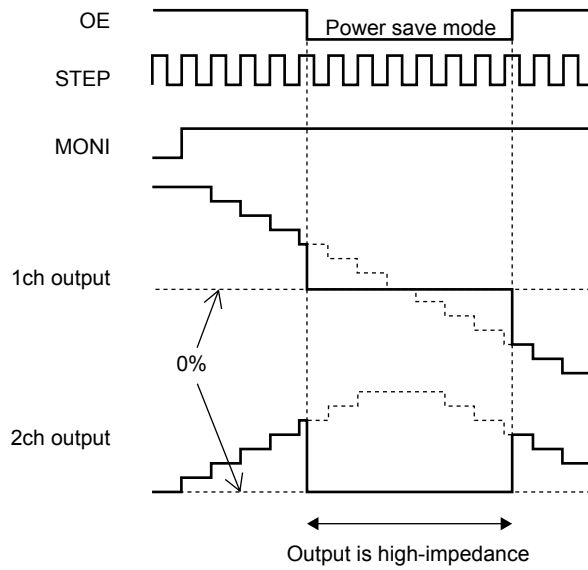

(7) Reset function

When the RST pin is set Low, the output goes to initial mode and excitation position is fixed in the initial position for STP pin and FR pin input. MO pin outputs at low levels at the initial position. (Open drain connection)

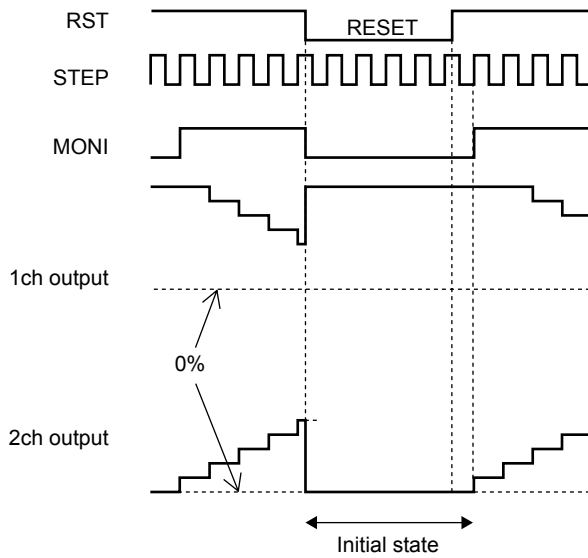

(8) Forward / reverse switching function

FR	Operating mode
Low	Clockwise (CW)
High	Counter-clockwise (CCW)

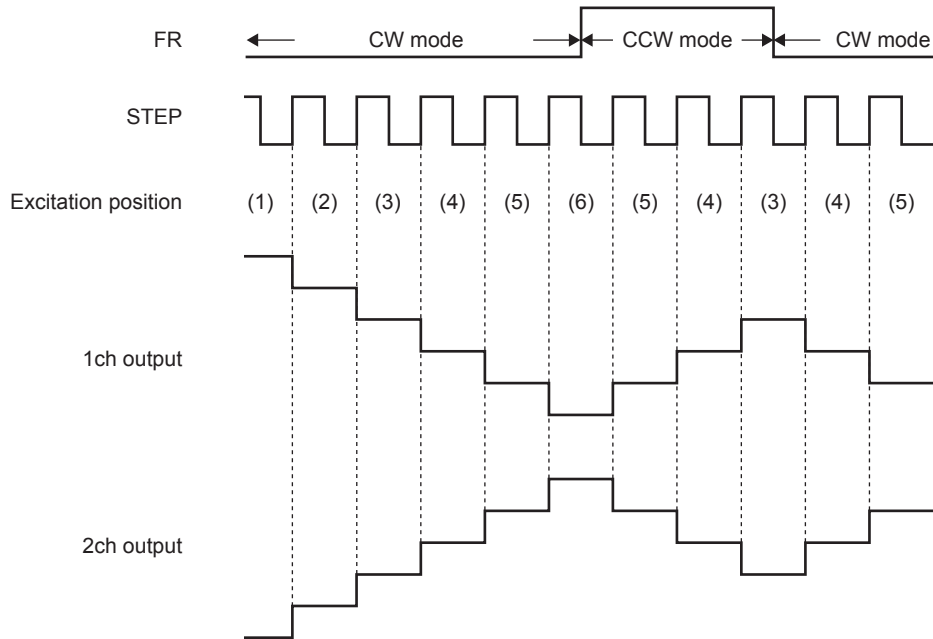

The internal D/A converter proceeds by a bit on the rising edge of the step signal input to the STP pin. In addition, CW and CCW mode are switched by FR pin setting.

In CW mode, the channel 2 current phase is delayed by 90° relative to the channel 1 current.

In CCW mode, the channel 2 current phase is advanced by 90° relative to the channel 1 current.

(9) EMO, DOWN, MO output pin

The output pin is open -drain connection. When it becomes prescribed, it turns on, and each pin outputs the Low level.

Pin state	EMO	DOWN	MO
Low	At detection of over-current	Holding current state	Initial position
OFF	Normal state	Normal state	Non initial position

(10) Chopping frequency setting function

Chopping frequency is set as shown below by a capacitor between OSC1 pin and GND.

$$F_{cp} = 1 / (C_{osc1} / 10 \times 10^{-6}) \text{ (Hz)}$$

(Example) When $C_{osc1} = 200\text{pF}$, the chopping frequency is shown below.

$$F_{cp} = 1 / (200 \times 10^{-12} / 10 \times 10^{-6}) = 50\text{(kHz)}$$

LV8729V

(11) Output current vector locus (one step is normalized to 90 degrees)

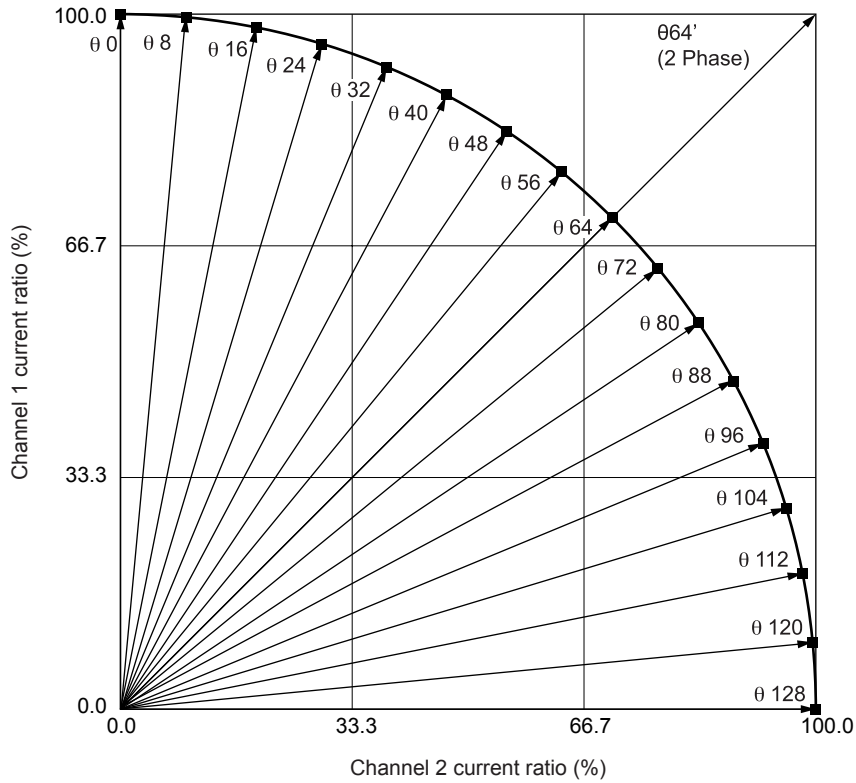

Current setting ratio in each excitation mode

STEP	32W1-2 phase(%)		16W1-2 phase(%)		8W1-2 phase(%)		4W1-2 phase(%)		2W1-2 phase (%)		W1-2 phase (%)		1-2 phase (%)		2 phase (%)	
	1ch	2ch	1ch	2ch	1ch	2ch	1ch	2ch	1ch	2ch	1ch	2ch	1ch	2ch	1ch	2ch
00	100	0	100	0	100	0	100	0	100	0	100	0	100	0		
01	100	1														
02	100	2	100	2												
03	100	4														
04	100	5	100	5	100	5										
05	100	6														
06	100	7	100	7												
07	100	9														
08	100	10	100	10	100	10	100	10								
09	99	11														
010	99	12	99	12												
011	99	13														
012	99	15	99	15	99	15										
013	99	16														
014	99	17	99	17												
015	98	18														
016	98	20	98	20	98	20	98	20	98	20						
017	98	21														
018	98	22	98	22												
019	97	23														
020	97	24	97	24	97	24										
021	97	25														
022	96	27	96	27												
023	96	28														
024	96	29	96	29	96	29	96	29								
025	95	30														

Continued on next page.

LV8729V

Continued from preceding page.

STEP	32W1-2 phase		16W1-2 phase		8W1-2 phase		4W1-2 phase		2W1-2 phase		W1-2 phase (%)		1-2 phase (%)		2 phase (%)	
	1ch	2ch	1ch	2ch	1ch	2ch	1ch	2ch	1ch	2ch	1ch	2ch	1ch	2ch	1ch	2ch
026	95	31	95	31												
027	95	33														
028	94	34	94	34	94	34										
029	94	35														
030	93	36	93	36												
031	93	37														
032	92	38	92	38	92	38	92	38	92	38	92	38				
033	92	39														
034	91	41	91	41												
035	91	42														
036	90	43	90	43	90	43										
037	90	44														
038	89	45	89	45												
039	89	46														
040	88	47	88	47	88	47	88	47								
041	88	48														
042	87	49	87	49												
043	86	50														
044	86	51	86	51	86	51										
045	85	52														
046	84	53	84	53												
047	84	55														
048	83	56	83	56	83	56	83	56	83	56						
049	82	57														
050	82	58	82	58												
051	81	59														
052	80	60	80	60	80	60										
053	80	61														
054	79	62	79	62												
055	78	62														
056	77	63	77	63	77	63	77	63								
057	77	64														
058	76	65	76	65												
059	75	66														
060	74	67	74	67	74	67										
061	73	68														
062	72	69	72	69												
063	72	70														
064	71	71	71	71	71	71	71	71	71	71	71	71	71	71	100	100
065	70	72														
066	69	72	69	72												
067	68	73														
068	67	74	67	74	67	74										
069	66	75														
070	65	76	65	76												
071	64	77														
072	63	77	63	77	63	77	63	77								
073	62	78														
074	62	79	62	79												
075	61	80														
076	60	80	60	80	60	80										
077	59	81														
078	58	82	58	82												
079	57	82														
080	56	83	56	83	56	83	56	83	56	83						
081	55	84														
082	53	84	53	84												
083	52	85														
084	51	86	51	86	51	86										
085	50	86														
086	49	87	49	87												
087	48	88														
088	47	88	47	88	47	88	47	88								
089	46	89														
090	45	89	45	89												

Continued on next page.

LV8729V

Continued from preceding page.

STEP	32W1-2 phase		16W1-2 phase		8W1-2 phase		4W1-2 phase		2W1-2 phase		W1-2 phase (%)		1-2 phase (%)		2 phase (%)	
	1ch	2ch	1ch	2ch	1ch	2ch	1ch	2ch	1ch	2ch	1ch	2ch	1ch	2ch	1ch	2ch
091	44	90														
092	43	90	43	90	43	90										
093	42	91														
094	41	91	41	91												
095	39	92														
096	38	92	38	92	38	92	38	92	38	92	38	92				
097	37	93														
098	36	93	36	93												
099	35	94														
0100	34	94	34	94	34	94										
0101	33	95														
0102	31	95	31	95												
0103	30	95														
0104	29	96	29	96	29	96	29	96								
0105	28	96														
0106	27	96	27	96												
0107	25	97														
0108	24	97	24	97	24	97										
0109	23	97														
0110	22	98	22	98												
0111	21	98														
0112	20	98	20	98	20	98	20	98	20	98						
0113	18	98														
0114	17	99	17	99												
0115	16	99														
0116	15	99	15	99	15	99										
0117	13	99														
0118	12	99	12	99												
0119	11	99														
0120	10	100	10	100	10	100	10	100								
0121	9	100														
0122	7	100	7	100												
0123	6	100														
0124	5	100	5	100	5	100										
0125	4	100														
0126	2	100	2	100												
0127	1	100														
0128	0	100	0	100	0	100	0	100	0	100	0	100	0	100		

LV8729V

(12) Current wave example in each excitation mode (2 phase, 1-2 phase, 4W1-2 phase, 32W1-2 phase)
2-phase excitation (CW mode)

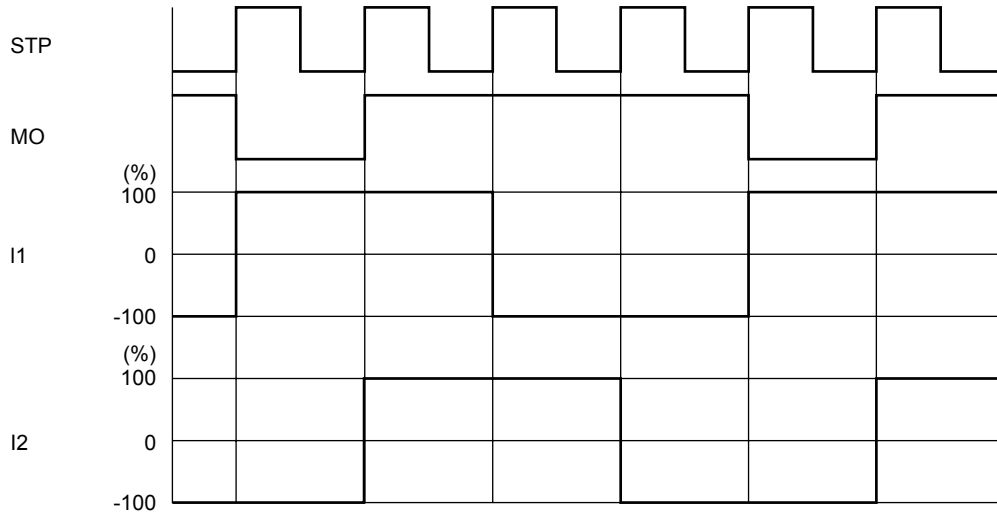

1-2 phase excitation (CW mode)

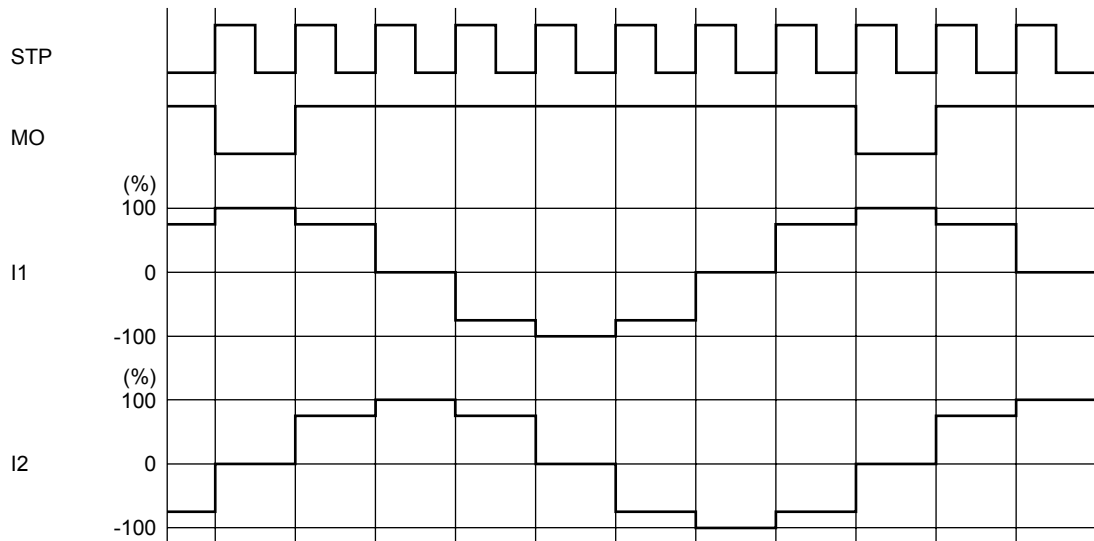

LV8729V

4W1-2 phase excitation (CW mode)

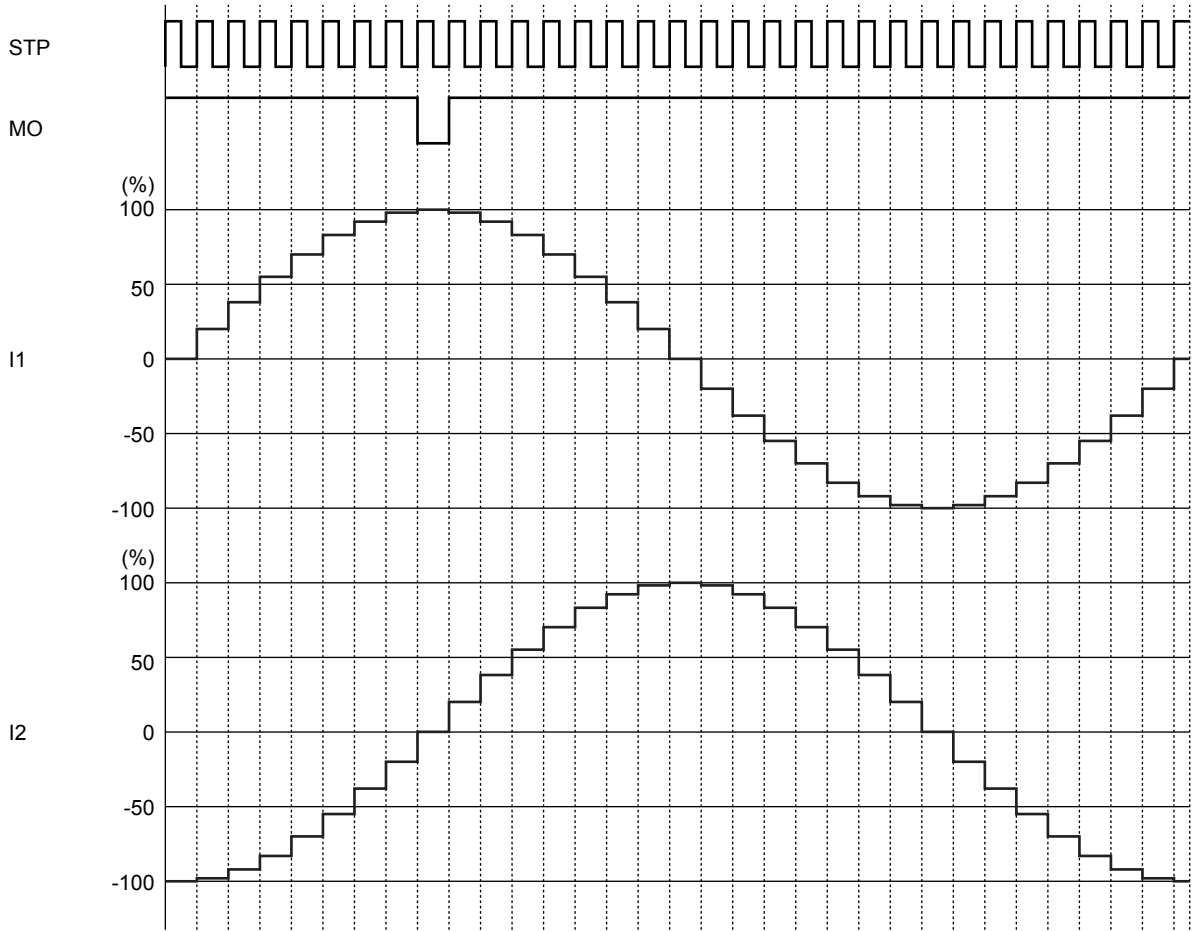

32W1-2 phase excitation (CW mode)

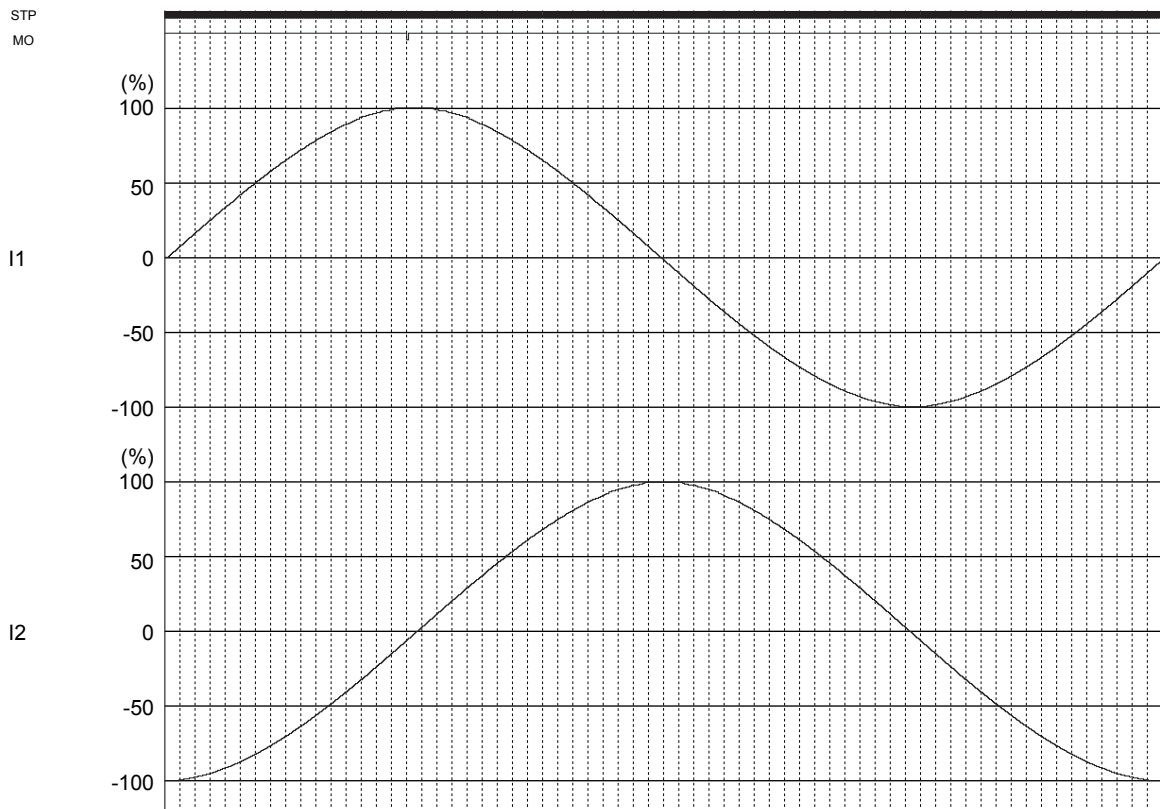

(13) Current control operation
(Sine-wave increasing direction)

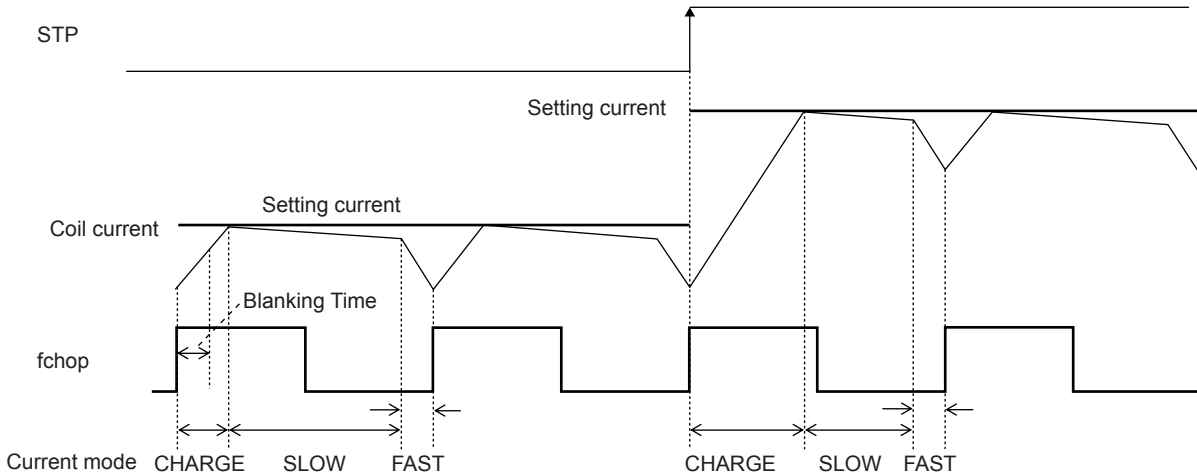

(Sine-wave decreasing direction)

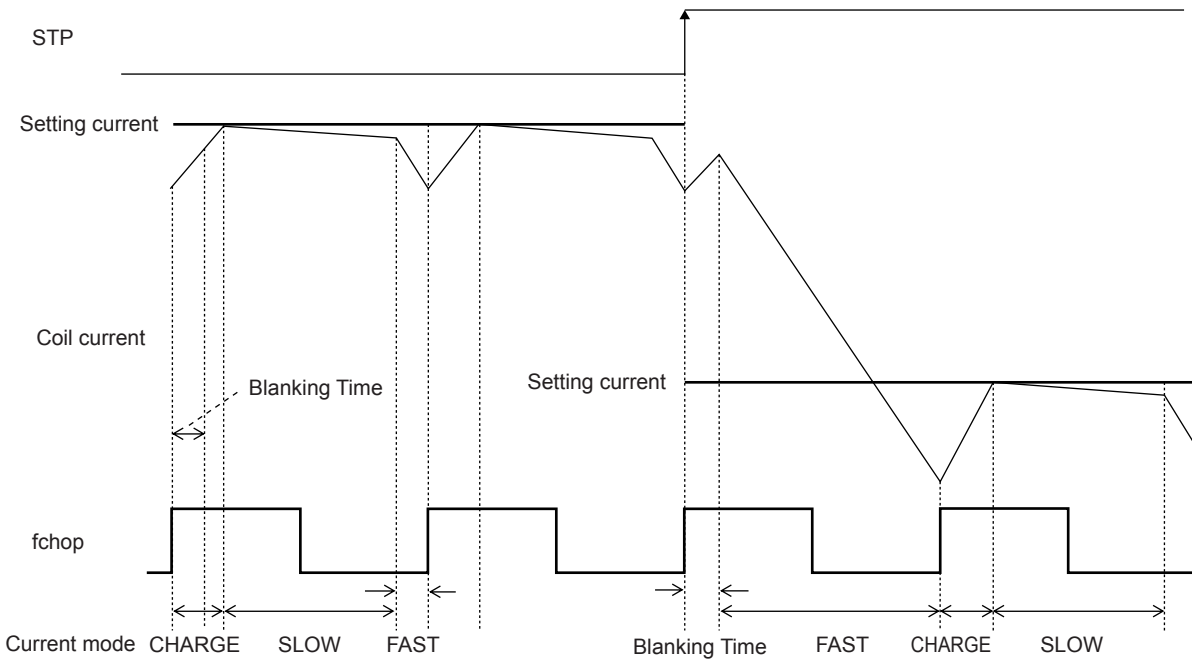

Each of current modes operates with the follow sequence.

- The IC enters CHARGE mode at a rising edge of the chopping oscillation. (A period of CHARGE mode (Blanking Time) is forcibly present in approximately 1 μ s, regardless of the current value of the coil current (ICOIL) and set current (IREF)).
- In a period of Blanking Time, the coil current (ICOIL) and the setting current (IREF) are compared.
 - If an $ICOIL < IREF$ state exists during the charge period:
 - The IC operates in CHARGE mode until $ICOIL \geq IREF$. After that, it switches to SLOW DECAy mode and then switches to FAST DECAy mode in the last approximately 1 μ s of the period.
 - If no $ICOIL < IREF$ state exists during the charge period:
 - The IC switches to FAST DECAy mode and the coil current is attenuated with the FAST DECAy operation until the end of a chopping period.

The above operation is repeated. Normally, in the sine wave increasing direction the IC operates in SLOW (+ FAST) DECAy mode, and in the sine wave decreasing direction the IC operates in FAST DECAy mode until the current is attenuated and reaches the set value and the IC operates in SLOW (+ FAST) DECAy mode.

(14) Output short-circuit protection circuit

Built-in output short-circuit protection circuit makes output to enter in stand-by mode. This function prevents the IC from damaging when the output shorts circuit by a voltage short or a ground short, etc. When output short state is detected, short-circuit detection circuit state the operating and output is once turned OFF. Subsequently, the output is turned ON again after the timer latch period (typ. 256 μ s). If the output remains in the short-circuit state, turn OFF the output, fix the output to the wait mode, and turn ON the EMO output.

When output is fixed in stand-by mode by output short protection circuit, output is released the latch by setting ST = "L".

(15) Open-drain pin for switching holding current

The output pin is an open-drain connection.

This pin is turned ON when no rising edge of STP between the input signals while a period determined by a capacitor between OSC2 and GND, and outputs at low levels.

The open-drain output in once turned ON, is turned OFF at the next rising edge of STP.

Holding current switching time (Tdown) is set as shown below by a capacitor between OSC2 pin and GND.

$$T_{\text{down}} = C_{\text{osc2}} \times 0.4 \times 10^9 \text{ (s)}$$

(Example) When C_{osc2} = 1500pF, the holding current switching time is shown below.

$$T_{\text{down}} = 1500\text{pF} \times 0.4 \times 10^9 = 0.6 \text{ (s)}$$

(16) Thermal shutdown function

The thermal shutdown circuit is incorporated and the output is turned off when junction temperature T_j exceeds 180°C and the abnormal state warning output is turned on. As the temperature falls by hysteresis, the output turned on again (automatic restoration).

The thermal shutdown circuit does not guarantee the protection of the final product because it operates when the temperature exceed the junction temperature of T_{jmax}=150°C.

$$T_{\text{SD}} = 180^\circ\text{C (typ)}$$

$$\Delta T_{\text{SD}} = 40^\circ\text{C (typ)}$$

LV8729V

Application Circuit Example

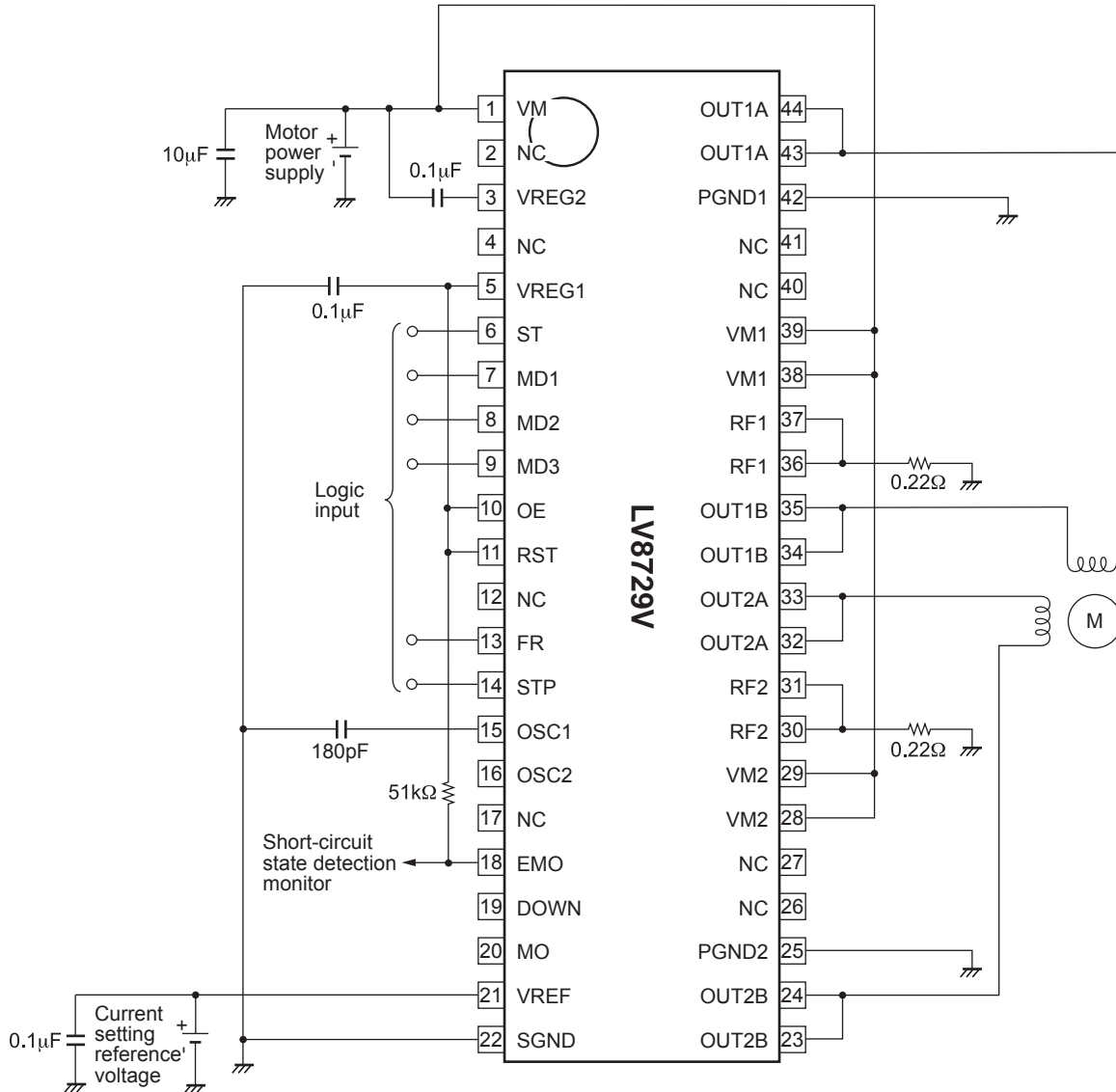

The above sample application circuit is set to the following conditions:

- Output enable function fixed to the output state (OE = "H")
- Reset function fixed to the output state (RST = "H")
- Chopping frequency : 55.5kHz (Cosc1 = 180pF)

The set current value is as follows :

$$I_{OUT} = (\text{Current setting reference voltage} / 5) / 0.22\Omega$$

ORDERING INFORMATION

Device	Package	Shipping (Qty / Packing)
LV8729V-TLM-H	SSOP44K (275mil) (Pb-Free / Halogen Free)	2000 / Tape & Reel
LV8729V-MPB-H	SSOP44K (275mil) (Pb-Free / Halogen Free)	30 / Fan-Fold

ON Semiconductor and the ON logo are registered trademarks of Semiconductor Components Industries, LLC (SCILLC). SCILLC owns the rights to a number of patents, trademarks, copyrights, trade secrets, and other intellectual property. A listing of SCILLC's product/patent coverage may be accessed at www.onsemi.com/site/pdf/Patent-Marking.pdf. SCILLC reserves the right to make changes without further notice to any products herein. SCILLC makes no warranty, representation or guarantee regarding the suitability of its products for any particular purpose, nor does SCILLC assume any liability arising out of the application or use of any product or circuit, and specifically disclaims any and all liability, including without limitation special, consequential or incidental damages. "Typical" parameters which may be provided in SCILLC data sheets and/or specifications can and do vary in different applications and actual performance may vary over time. All operating parameters, including "Typicals" must be validated for each customer application by customer's technical experts. SCILLC does not convey any license under its patent rights nor the rights of others. SCILLC products are not designed, intended, or authorized for use as components in systems intended for surgical implant into the body, or other applications intended to support or sustain life, or for any other application in which the failure of the SCILLC product could create a situation where personal injury or death may occur. Should Buyer purchase or use SCILLC products for any such unintended or unauthorized application, Buyer shall indemnify and hold SCILLC and its officers, employees, subsidiaries, affiliates, and distributors harmless against all claims, costs, damages, and expenses, and reasonable attorney fees arising out of, directly or indirectly, any claim of personal injury or death associated with such unintended or unauthorized use, even if such claim alleges that SCILLC was negligent regarding the design or manufacture of the part. SCILLC is an Equal Opportunity/Affirmative Action Employer. This literature is subject to all applicable copyright laws and is not for resale in any manner.

X-ON Electronics

Largest Supplier of Electrical and Electronic Components

Click to view similar products for [Power Management IC Development Tools](#) *category:*

Click to view products by [ON Semiconductor](#) *manufacturer:*

Other Similar products are found below :

[EVAL-ADM1168LQEBZ](#) [EVB-EP5348UI](#) [MIC23451-AAAYFL EV](#) [MIC5281YMME EV](#) [DA9063-EVAL](#) [ADP122-3.3-EVALZ](#) [ADP130-0.8-EVALZ](#) [ADP130-1.2-EVALZ](#) [ADP130-1.5-EVALZ](#) [ADP130-1.8-EVALZ](#) [ADP1712-3.3-EVALZ](#) [ADP1714-3.3-EVALZ](#) [ADP1715-3.3-EVALZ](#) [ADP1716-2.5-EVALZ](#) [ADP1740-1.5-EVALZ](#) [ADP1752-1.5-EVALZ](#) [ADP1828LC-EVALZ](#) [ADP1870-0.3-EVALZ](#) [ADP1871-0.6-EVALZ](#) [ADP1873-0.6-EVALZ](#) [ADP1874-0.3-EVALZ](#) [ADP1882-1.0-EVALZ](#) [ADP199CB-EVALZ](#) [ADP2102-1.25-EVALZ](#) [ADP2102-1.875EVALZ](#) [ADP2102-1.8-EVALZ](#) [ADP2102-2-EVALZ](#) [ADP2102-3-EVALZ](#) [ADP2102-4-EVALZ](#) [ADP2106-1.8-EVALZ](#) [ADP2147CB-110EVALZ](#) [AS3606-DB](#) [BQ24010EVM](#) [BQ24075TEVM](#) [BQ24155EVM](#) [BQ24157EVM-697](#) [BQ24160EVM-742](#) [BQ24296MEVM-655](#) [BQ25010EVM](#) [BQ3055EVM](#) [NCV891330PD50GEVB](#) [ISLUSBI2CKIT1Z](#) [LM2744EVAL](#) [LM2854EVAL](#) [LM3658SD-AEV/NOPB](#) [LM3658SDEV/NOPB](#) [LM3691TL-1.8EV/NOPB](#) [LM4510SDEV/NOPB](#) [LM5033SD-EVAL](#) [LP38512TS-1.8EV](#)