

LV8741V



ON Semiconductor®

www.onsemi.com

Bi-CMOS IC

PWM Current Control Stepper Motor Driver

Overview

The LV8741V is a 2-channel H-bridge driver IC that can switch a stepper motor driver, which is capable of micro-step drive and supports Quarter-step excitation, and two channels of a brushed motor driver, which supports forward, reverse, brake, and standby of a motor. It is ideally suited for driving brushed DC motors and stepper motors used in office equipment and amusement applications.

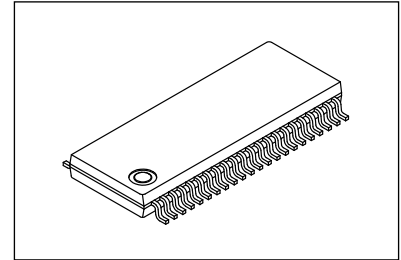

SSOP44K (275mil)

Feature

- Single-channel PWM current control stepper motor driver (selectable with DC motor driver channel 2) incorporated.
- BiCDMOS process IC
- On resistance (upper side : 0.5Ω ; lower side : 0.5Ω ; total of upper and lower : 1.0Ω ; $T_a = 25^\circ\text{C}$, $I_O = 1.5\text{A}$)
- Excitation mode can be set to Full-step, Half-step full torque, Half-step or Quarter-step
- Excitation step proceeds only by step signal input
- Motor current selectable in four steps
- $I_O \text{ max} = 1.5\text{A}$
- Output short-circuit protection circuit (selectable from latch-type or auto reset-type) incorporated
- Thermal shutdown circuit and power supply monitor circuit incorporated
- Support control power supply $V_{CC} = 2.7\text{V}$ to 5.5V

Typical Applications

- Stepper/Brush DC Motors
- Computing & Peripherals, Industrial
- Printers, Inkjet Printer, Multi-Function Printer
- Flatbed Scanner, Document Scanner
- Slot Machine, Vending Machine, Cash Machine

ORDERING INFORMATION

See detailed ordering and shipping information on page 28 of this data sheet.

LV8741V

Specifications

Absolute Maximum Ratings at Ta = 25°C

Parameter	Symbol	Conditions	Ratings	Unit
Supply voltage 1	V _M max	VM, VM1, VM2	38	V
Supply voltage 2	V _{CC} max		6	V
Output peak current	I _O peak	tw ≤ 10ms, duty 20%, Per 1ch	1.75	A
Output current	I _O max	Per 1ch	1.5	A
Logic input voltage	V _{IN}	ST, OE, DM, MD1/DC11, MD2/DC12, FR/DC21, STP/DC22, RST, EMM, ATT1, ATT2	-0.3 to V _{CC} +0.3	V
EMO input voltage	V _{EMO}		-0.3 to V _{CC} +0.3	V
Allowable power dissipation 1	Pd max1	Independent IC	0.55	W
Allowable power dissipation 2	Pd max2	*	2.9	W
Operating temperature	T _{opr}		-20 to +85	°C
Storage temperature	T _{stg}		-55 to +150	°C

* Specified circuit board : 90×90×1.7mm³ : glass epoxy printed circuit board with back mounting.

Caution 1) Absolute maximum ratings represent the value which cannot be exceeded for any length of time.

Caution 2) Even when the device is used within the range of absolute maximum ratings, as a result of continuous usage under high temperature, high current, high voltage, or drastic temperature change, the reliability of the IC may be degraded. Please contact us for the further details.

Stresses exceeding those listed in the Maximum Ratings table may damage the device. If any of these limits are exceeded, device functionality should not be assumed, damage may occur and reliability may be affected.

Recommended Operating Conditions at Ta = 25°C

Parameter	Symbol	Conditions	Ratings	Unit
Supply voltage range 1	V _M	VM, VM1, VM2	9.5 to 35	V
Supply voltage range 2	V _{CC}		2.7 to 5.5	V
VREF input voltage range	VREF		0 to V _{CC} -1.8	V
Logic voltage range	V _{IN}	ST, OE, DM, MD1/DC11, MD2/DC12, FR/DC21, STP/DC22, RST, EMM, ATT1, ATT2	0 to V _{CC}	V

Functional operation above the stresses listed in the Recommended Operating Ranges is not implied. Extended exposure to stresses beyond the Recommended Operating Ranges limits may affect device reliability.

LV8741V

Electrical Characteristics at Ta = 25°C, VM = 24V, VCC = 5V, VREF = 1.5V

Parameter	Symbol	Conditions	Ratings			Unit	
			min	typ	max		
Standby mode current drain 1	IMstn	ST = "L", I(VM)+I(VM1)+I(VM2)		150	200	μA	
Current drain 1	IM	ST = "H", OE = "H", no load I(VM)+I(VM1)+I(VM2)		0.75	1	mA	
Standby mode current drain 2	ICCstn	ST = "L"		110	160	μA	
Current drain 2	ICC	ST = "H", OE = "H", no load		2.5	3	mA	
VCC low-voltage cutoff voltage	VthVCC	ST = "H", OE = "H", no load	2.2	2.35	2.5	V	
Low-voltage hysteresis voltage	VthHIS		100	150	200	mV	
Thermal shutdown temperature	TSD	Design guarantee		180		°C	
Thermal hysteresis width	ΔTSD	Design guarantee		40		°C	
Output on-resistance							
Output on-resistance	Ronu	IO = 1.5A, Upper-side on resistance		0.5	0.7	Ω	
	Rond	IO = 1.5A, Lower-side on resistance		0.5	0.6	Ω	
Output leakage current	IOleak	VM = 35V			50	μA	
Diode forward voltage 1	VD1	ID = -1.0A		1	1.3	V	
Diode forward voltage 2	VD2	ID = -1.5A		1.1	1.5	V	
Logic pin input current	IINL	ST, OE, DM, MD1/DC11, MD2/DC12, FR/DC21, STP/DC22, RST, EMM, ATT1, ATT2, VIN = 0.8V	3	8	15	μA	
	IINH	VIN = 5V	30	50	70	μA	
Logic input voltage	High	VINh	ST, OE, DM, MD1/DC11, MD2/DC12, FR/DC21, STP/DC22, RST, EMM, ATT1, ATT2	2.0	VCC	V	
	Low	VINL		0	0.8	V	
Current selection reference voltage level	Quarter step resolution	Vtdac0_W	Step 0(When initialized : channel 1 comparator level)	0.485	0.5	0.515	V
		Vtdac1_W	Step 1 (Initial state+1)	0.485	0.5	0.515	V
		Vtdac2_W	Step 2 (Initial state+2)	0.323	0.333	0.343	V
		Vtdac3_W	Step 3 (Initial state+3)	0.155	0.167	0.179	V
	Half step resolution	Vtdac0_H	Step 0 (When initialized: channel 1 comparator level)	0.485	0.5	0.515	V
		Vtdac2_H	Step 2 (Initial state+1)	0.323	0.333	0.343	V
	Half step resolution (full torque)	Vtdac0_HF	Step 0 (Initial state, channel 1 comparator level)	0.485	0.5	0.515	V
		Vtdac2_HF	Step 2 (Initial state+1)	0.485	0.5	0.515	V
Full step resolution	Vtdac2_F	Step 2	0.485	0.5	0.515	V	
Chopping frequency	Fchop	RCHOP = 20kΩ	45	62.5	75	kHz	
Current setting reference voltage	VRF00	ATT1 = L, ATT2 = L	0.485	0.5	0.515	V	
	VRF01	ATT1 = H, ATT2 = L	0.323	0.333	0.343	V	
	VRF10	ATT1 = L, ATT2 = H	0.237	0.25	0.263	V	
	VRF11	ATT1 = H, ATT2 = H	0.155	0.167	0.179	V	
VREF pin input current	Iref	VREF = 1.5V	-0.5			μA	
Charge pump							
VREG5 output voltage	Vreg5	IO = -1mA	4.5	5	5.5	V	
VG output voltage	VG		28	28.7	29.8	V	
Rise time	tONG	VG = 0.1μF, Between CP1-CP2 0.1μF ST="H"→VG = VM+4V			0.5	ms	
Oscillator frequency	Fosc	RCHOP = 20kΩ	90	125	150	kHz	
Output short-circuit protection							
EMO pin saturation voltage		Iemo = 1mA		50	100	mV	

Product parametric performance is indicated in the Electrical Characteristics for the listed test conditions, unless otherwise noted. Product performance may not be indicated by the Electrical Characteristics if operated under different conditions.

LV8741V

Package Dimensions

unit : mm

SSOP44K (275mil) Exposed Pad
CASE 940AF
ISSUE A

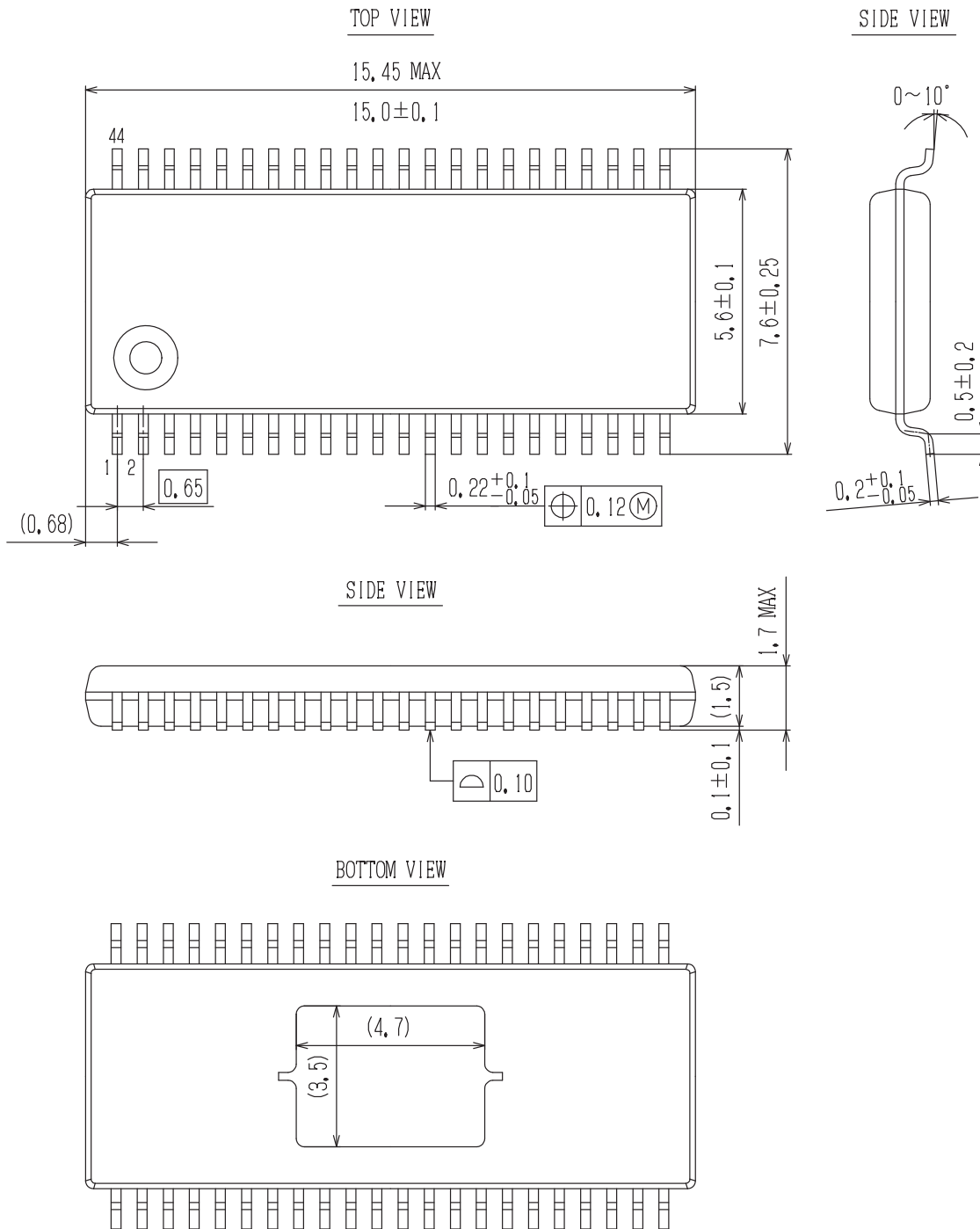

SOLDERING FOOTPRINT*

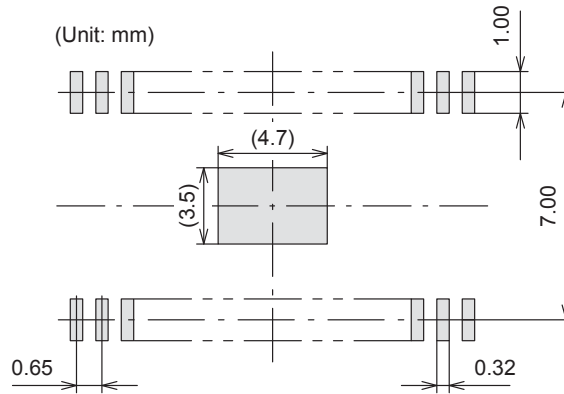

NOTES:

1. The measurements are for reference only, and unable to guarantee.
2. Please take appropriate action to design the actual Exposed Die Pad and Fin portion.
3. After setting, verification on the product must be done.
 (Although there are no recommended design for Exposed Die Pad and Fin portion Metal mask and shape for Through-Hole pitch (Pitch & Via etc), checking the soldered joint condition and reliability verification of soldered joint will be needed. Void ▯ gradient ▯ insufficient thickness of soldered joint or bond degradation could lead IC destruction because thermal conduction to substrate becomes poor.)

*For additional information on our Pb-Free strategy and soldering details, please download the ON Semiconductor Soldering and Mounting Techniques Reference Manual, SOLDERRM/D.

GENERIC MARKING DIAGRAM*

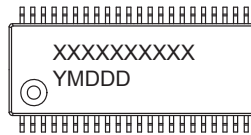

XXXXXX = Specific Device Code
 Y = Year
 M = Month
 DDD = Additional Traceability Data

*This information is generic. Please refer to device data sheet for actual part marking. Pb-Free indicator, "G" or microdot "▪", may or may not be present.

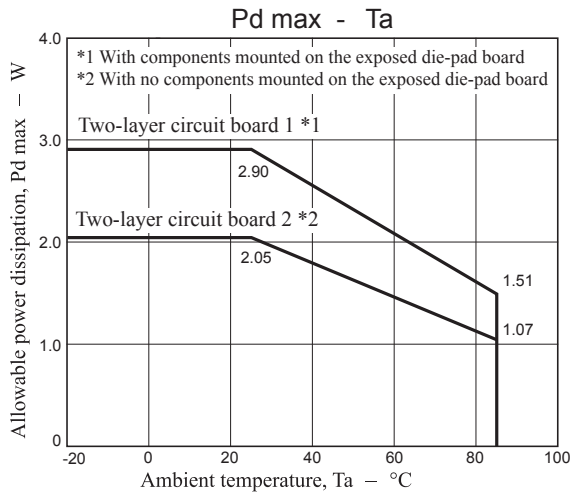

Substrate Specifications (Substrate recommended for operation of LV8741V)

- Size : 90mm × 90mm × 1.7mm (two-layer substrate [2S0P])
- Material : Glass epoxy
- Copper wiring density : L1 = 90% / L2 = 95%

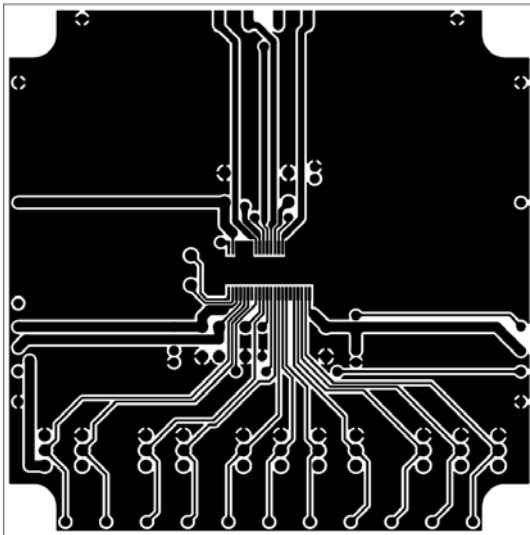

L1 : Copper wiring pattern diagram

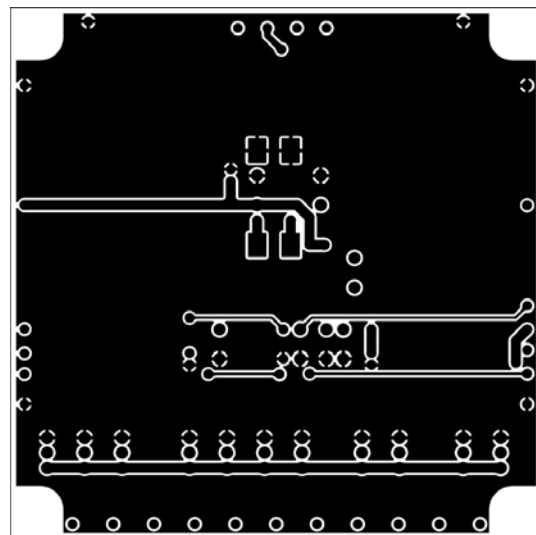

L2 : Copper wiring pattern diagram

Cautions

- 1) The data for the case with the Exposed Die-Pad substrate mounted shows the values when 95% or more of the Exposed Die-Pad is wet.
- 2) For the set design, employ the derating design with sufficient margin.
Stresses to be derated include the voltage, current, junction temperature, power loss, and mechanical stresses such as vibration, impact, and tension.
Accordingly, the design must ensure these stresses to be as low or small as possible.
The guideline for ordinary derating is shown below :
 - (1)Maximum value 80% or less for the voltage rating
 - (2)Maximum value 80% or less for the current rating
 - (3)Maximum value 80% or less for the temperature rating
- 3) After the set design, be sure to verify the design with the actual product.
Confirm the solder joint state and verify also the reliability of solder joint for the Exposed Die-Pad, etc.
Any void or deterioration, if observed in the solder joint of these parts, causes deteriorated thermal conduction, possibly resulting in thermal destruction of IC.

LV8741V

Pin Assignment

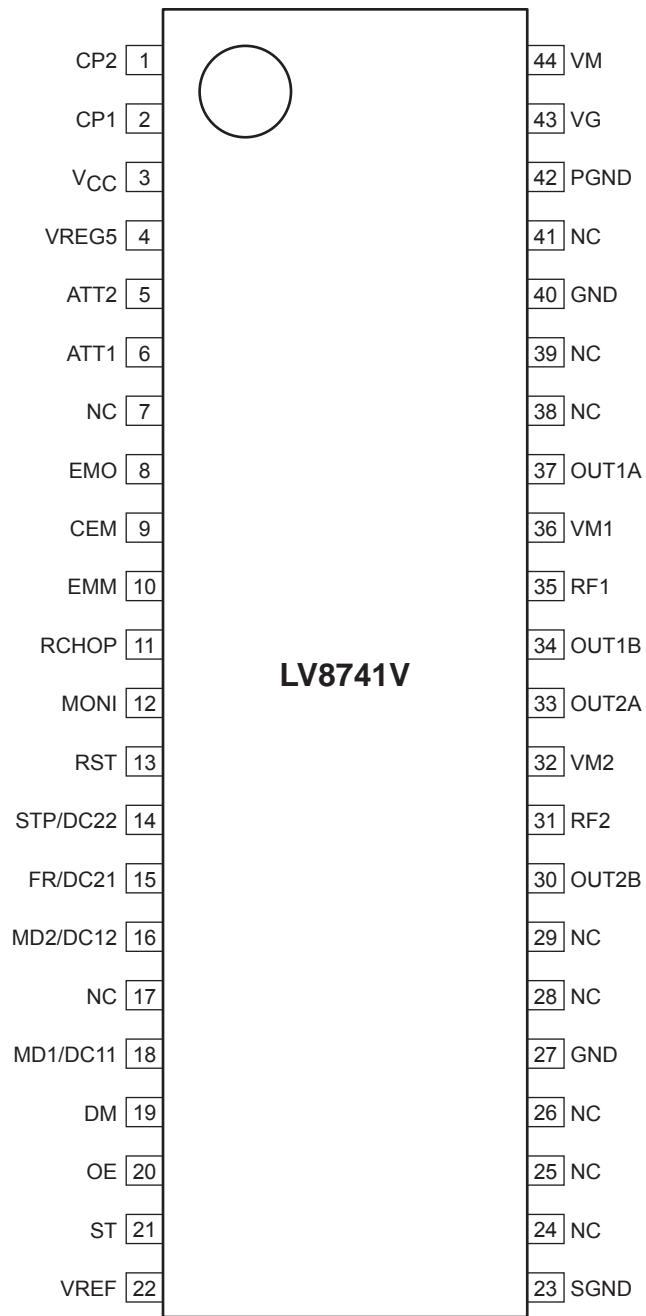

Top view

Block Diagram

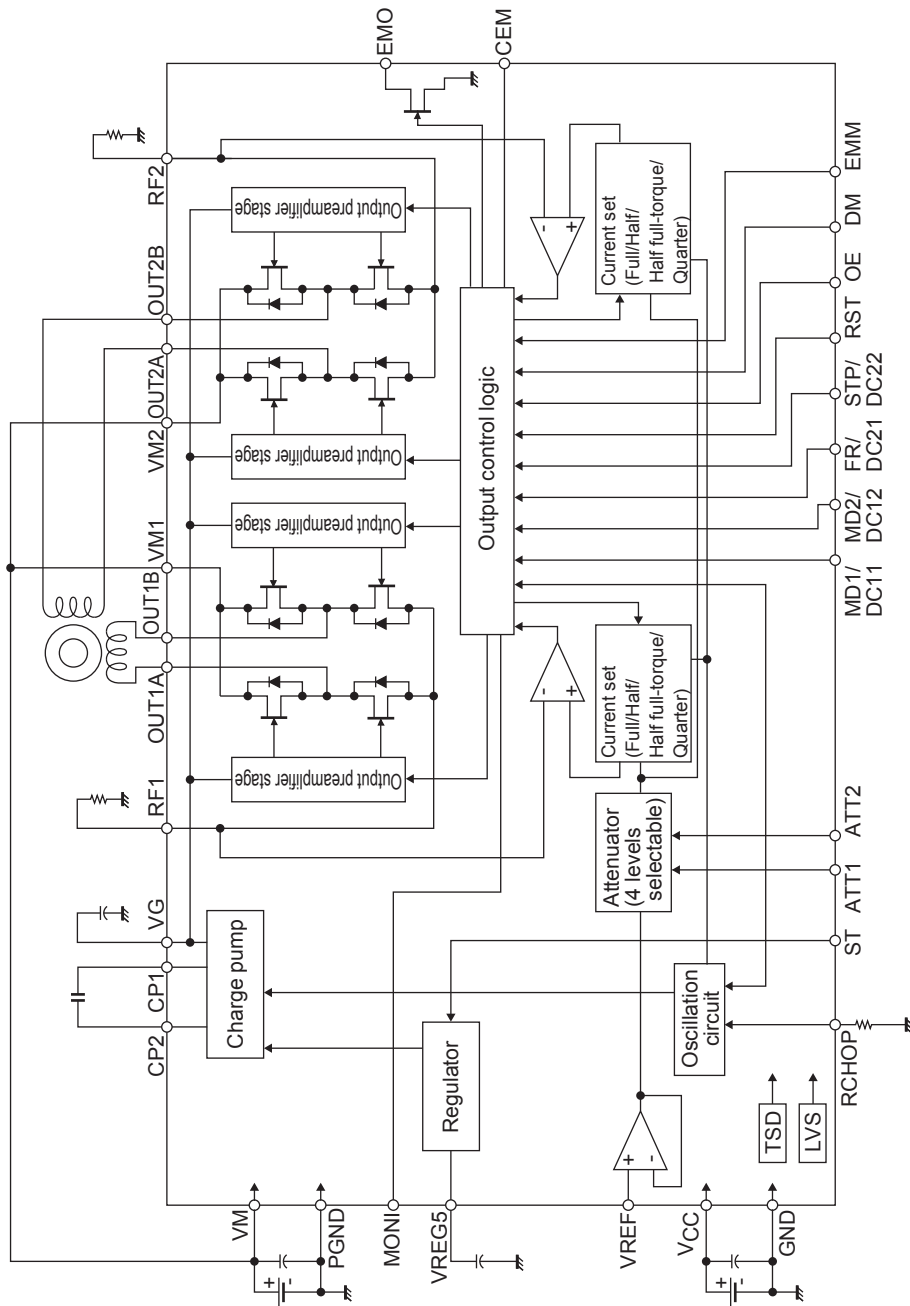

LV8741V

Pin Functions

Pin No.	Pin name	Description
36	VM1	Channel 1 motor power supply pin
37	OUT1A	Channel 1 OUTA output pin
34	OUT1B	Channel 1 OUTB output pin
35	RF1	Channel 1 current-sense resistor connection pin
32	VM2	Channel 2 motor power supply connection pin
33	OUT2A	Channel 2 OUTA output pin
30	OUT2B	Channel 2 OUTB output pin
31	RF2	Channel 2 current-sense resistor connection pin
42	PGND	Power system ground
12	MONI	Position detection monitor pin
14	STP/DC22	STM STEP signal input pin/DCM2 output control input pin
22	VREF	Constant current control reference voltage input pin
18	MD1/DC11	STM excitation mode switching pin/DCM1 output control input pin
16	MD2/DC12	STM excitation mode switching pin/DCM1 output control input pin
13	RST	Reset signal input pin
20	OE	Output enable signal input pin
15	FR/DC21	STM forward/reverse rotation signal input pin/DCM2 output control input pin
6	ATT1	Motor holding current switching pin
5	ATT2	Motor holding current switching pin
21	ST	Chip enable pin
44	VM	Motor power supply connection pin
3	V _{CC}	Logic power supply connection pin
23	GND	Signal system ground
11	RCHOP	Chopping frequency setting resistor connection pin
19	DM	Drive mode (STM/DCM) switching pin
4	VREG5	Internal power supply capacitor connection pin
2	CP1	Charge pump capacitor connection pin
1	CP2	Charge pump capacitor connection pin
43	VG	Charge pump capacitor connection pin
8	EMO	Output short-circuit state warning output pin
10	EMM	Overcurrent mode switching pin
9	CEM	Pin to connect the output short-circuit state detection time setting capacitor
27,40	GND	Ground
7, 17, 24, 25, 26, 28, 29, 38, 39, 41	NC	No Connection (No internal connection to the IC)

LV8741V

Equivalent Circuits

Pin No.	Pin	Equivalent Circuit
5 6 10 13 14 15 16 18 19 20 21	ATT2 ATT1 EMM RST STP/DC22 FR/DC21 MD2/DC12 MD1/DC11 DM OE ST	
30 31 32 33 34 35 36 37 42	OUT2B RF2 VM2 OUT2A OUT1B RF1 VM1 OUT1A PGND	
1 2 43 44	CP2 CP1 VG VM	

Continued on next page.

LV8741V

Continued from preceding page.

Pin No.	Pin	Equivalent Circuit
22	VREF	
4	VREG5	
12	MONI	

Continued on next page.

LV8741V

Continued from preceding page.

Pin No.	Pin	Equivalent Circuit
8	EMO	
9	CEM	
11	RCHOP	

Description of operation

1. Input Pin Function

1-1) Chip enable function

This IC is switched between standby and operating mode by setting the ST pin. In standby mode, the IC is set to power-save mode and all logic is reset. In addition, the internal regulator circuit and charge pump circuit do not operate in standby mode.

ST	Mode	Internal regulator	Charge pump
Low or Open	Standby mode	Standby	Standby
High	Operating mode	Operating	Operating



1-2) Drive mode switching pin function

The IC drive mode is switched by setting the DM pin. In STM mode, stepper motor channel 1 can be controlled by the CLK-IN input. In DCM mode, DC motor channel 2 or stepper motor channel 1 can be controlled by parallel input. Stepper motor control using parallel input is Full-step or Half-step full torque.

DM	Drive mode	Application
Low or Open	STM mode	Stepper motor channel 1 (CLK-IN)
High	DCM mode	DC motor channel 2 or stepper motor channel 1 (parallel)

2. STM mode (DM = Low or Open)

2-1) STEP pin function

Input		Operating mode
ST	STP	
Low	*	Standby mode
High		Excitation step proceeds
High		Excitation step is kept

2-2) Excitation mode setting function

MD1	MD2	Micro-step resolution (Excitation mode)	Initial position	
			Channel 1	Channel 2
Low	Low	Full step (2 phase excitation)	100%	-100%
High	Low	Half step (1-2 phase excitation) full torque	100%	0%
Low	High	Half step (1-2 phase excitation)	100%	0%
High	High	Quarter step (W1-2 phase excitation)	100%	0%

This is the initial position of each excitation mode in the initial state after power-on and when the counter is reset.

2-3) Constant-current control reference voltage setting function

ATT1	ATT2	Current setting reference voltage
Low	Low	VREF/3×100%
High	Low	VREF/3×67%
Low	High	VREF/3×50%
High	High	VREF/3×33%

The voltage input to the VREF pin can be switched to four-step settings as the reference voltage for setting the output current. This is effective for reducing power consumption when motor holding current is supplied.

Set current value calculation method

The reference voltage is set by the voltage applied to the VREF pin and the two inputs ATT1 and ATT2. The output current (output current at a constant-current drive current ratio of 100%) can be set from this reference voltage and the RF resistance value.

$$I_{OUT} = (VREF/3 \times \text{Voltage setting ratio})/RF \text{ resistor}$$

(Example) When $V_{REF} = 0.66V$, setting current ratio = 100% [(ATT1, ATT2) = (Low, Low)] and R_F resistor = 0.22Ω , the following output current flows :

$$I_{OUT} = 0.66V/3 \times 100\%/0.22\Omega = 1A$$

2-4) Input Timing

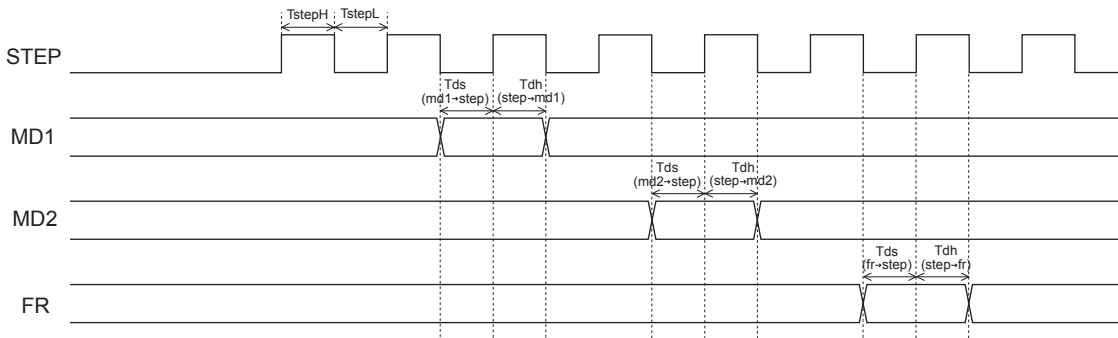

TstepH/TstepL : Clock H/L pulse width (min 500ns)
 Tds : Data set-up time (min 500ns)
 Tdh : Data hold time (min 500ns)

2-5) Blanking period

If, when exercising PWM constant-current chopping control over the motor current, the mode is switched from decay to charge, the recovery current of the parasitic diode may flow to the current sensing resistance, causing noise to be carried on the current sensing resistance pin, and this may result in erroneous detection. To prevent this erroneous detection, a blanking period is provided to prevent the noise occurring during mode switching from being received. During this period, the mode is not switched from charge to decay even if noise is carried on the current sensing resistance pin. In the blanking time for this IC, it is fixed one sixteenth of chopping cycle.

2-6) Reset function

RST	Operating mode
High	Normal operation
Low	Reset state

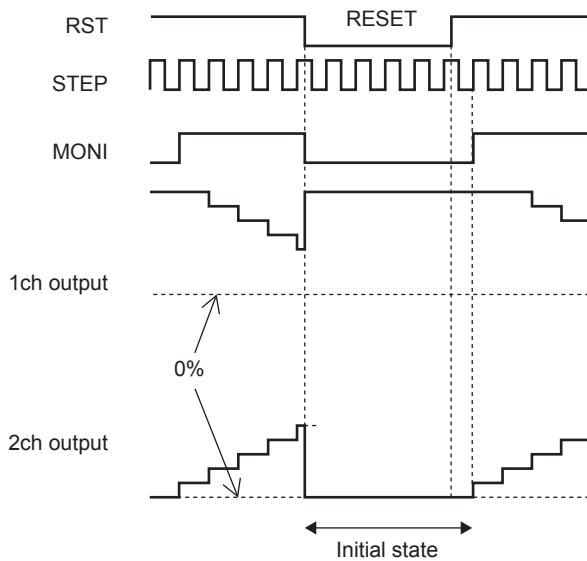

When the RST pin is set Low, the output excitation position is forced to the initial state, and the MONI output also goes Low.
 When RST is set High after that, the excitation position proceeds to the next STEP input.

2-7) Output enable function

OE	Operating mode
Low	Output OFF
High	Output ON

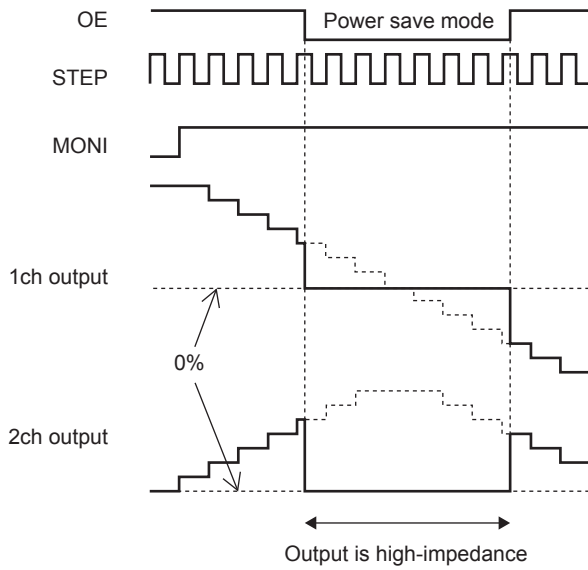

When the OE pin is set Low, the output is forced OFF and goes to high impedance. However, the internal logic circuits are operating, so the excitation position proceeds when the STEP signal is input. Therefore, when OE is returned to High, the output level conforms to the excitation position proceeded by the STEP input.

2-8) Forward/reverse switching function

FR	Operating mode
Low	Clockwise (CW)
High	Counter-clockwise (CCW)

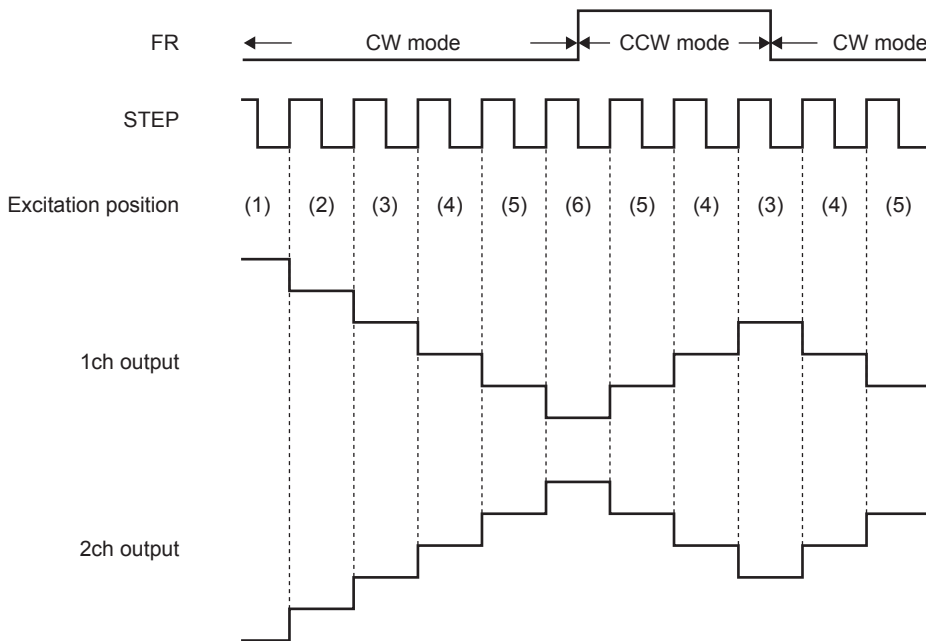

The internal D/A converter proceeds by one bit at the rising edge of the input STEP pulse. In addition, CW and CCW mode are switched by setting the FR pin. In CW mode, the channel 2 current phase is delayed by 90° relative to the channel 1 current. In CCW mode, the channel 2 current phase is advanced by 90° relative to the channel 1 current.

2-9) Setting the chopping frequency

For constant-current control, chopping operation is made with the frequency determined by the external resistor (connected to the RCHOP pin).

The chopping frequency to be set with the resistance connected to the RCHOP pin (pin 11) is as shown below.

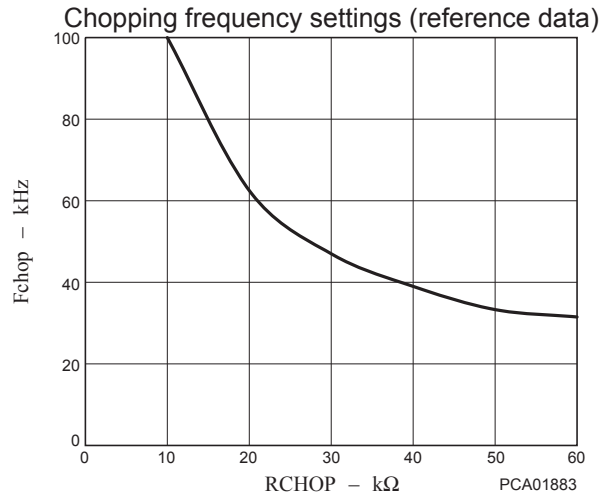

LV8741V

2-10) Output current vector locus (one step is normalized to 90 degrees)

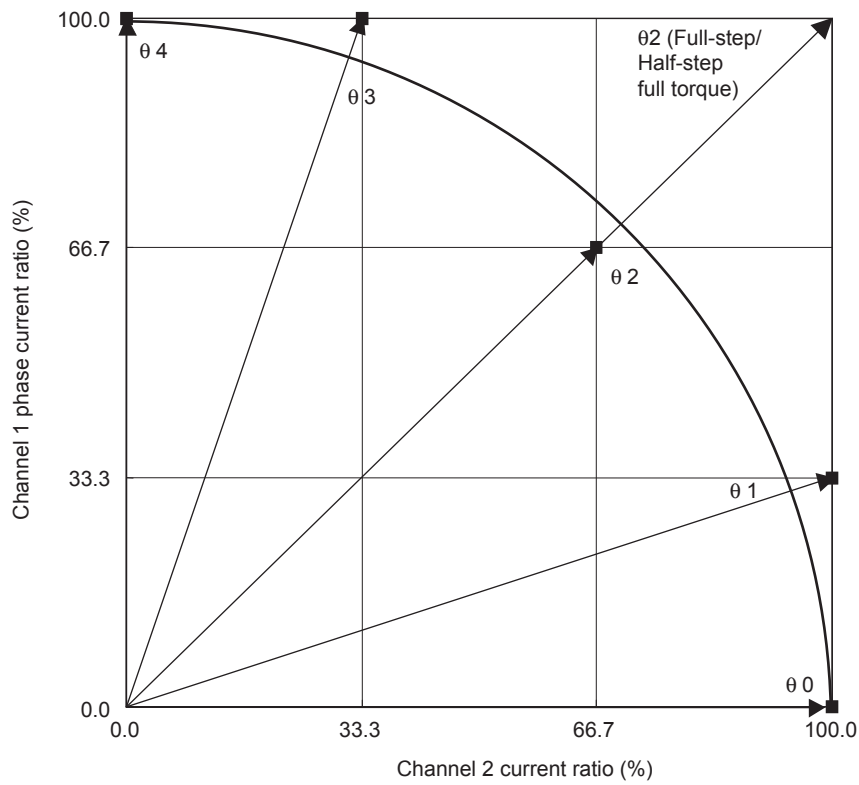

Setting current ration in each micro-step mode

STEP	Quarter-step (%)		Half-step (%)		Half-step full torque (%)		Full-step (%)	
	Channel 1	Channel 2	Channel 1	Channel 2	Channel 1	Channel 2	Channel 1	Channel 2
00	0	100	0	100	0	100		
01	33.3	100						
02	66.7	66.7	66.7	66.7	100	100	100	100
03	100	33.3						
04	100	0	100	0	100	0		

2-11) Examples of current waveform in each micro-step mode
Full step (CW mode)

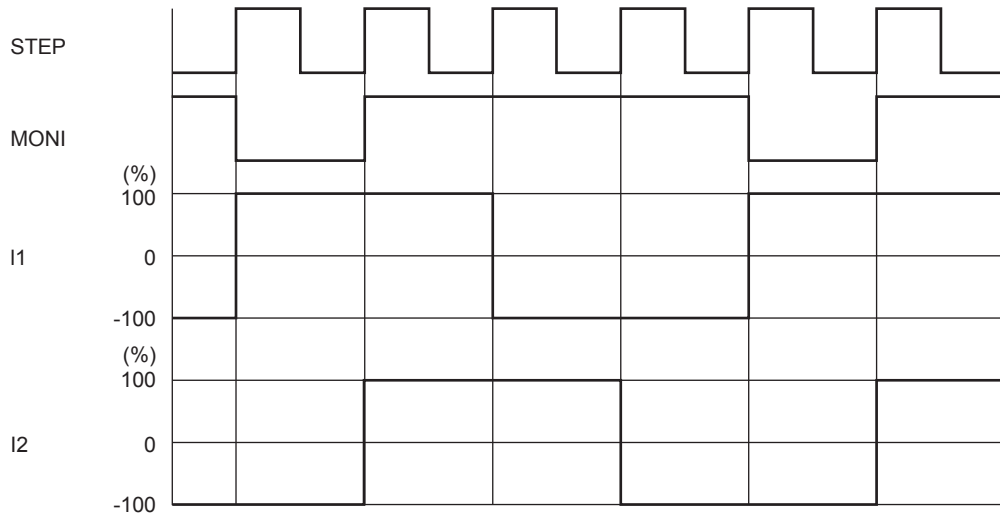

Half step full torque (CW mode)

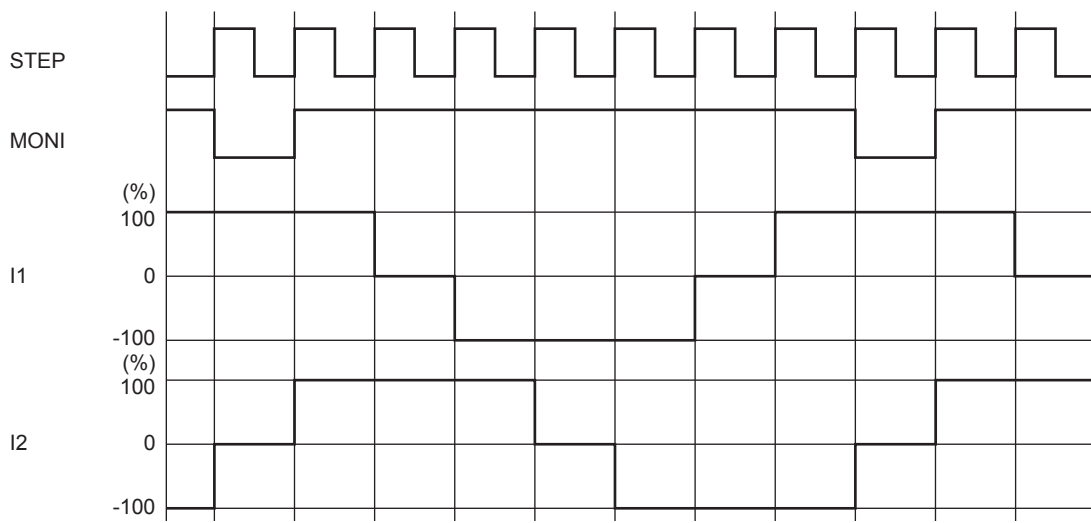

Half step (CW mode)

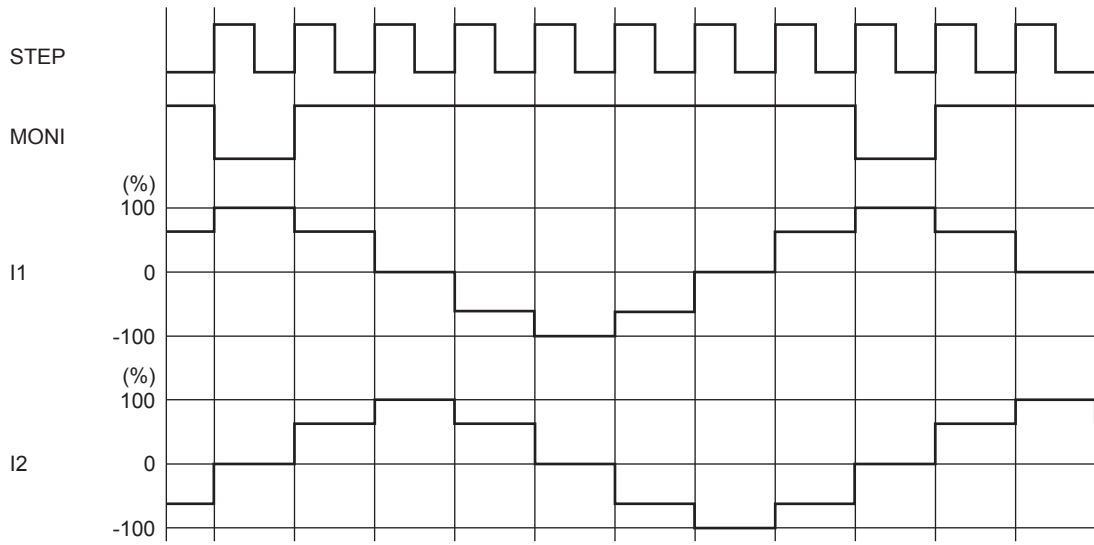

Quarter step (CW mode)

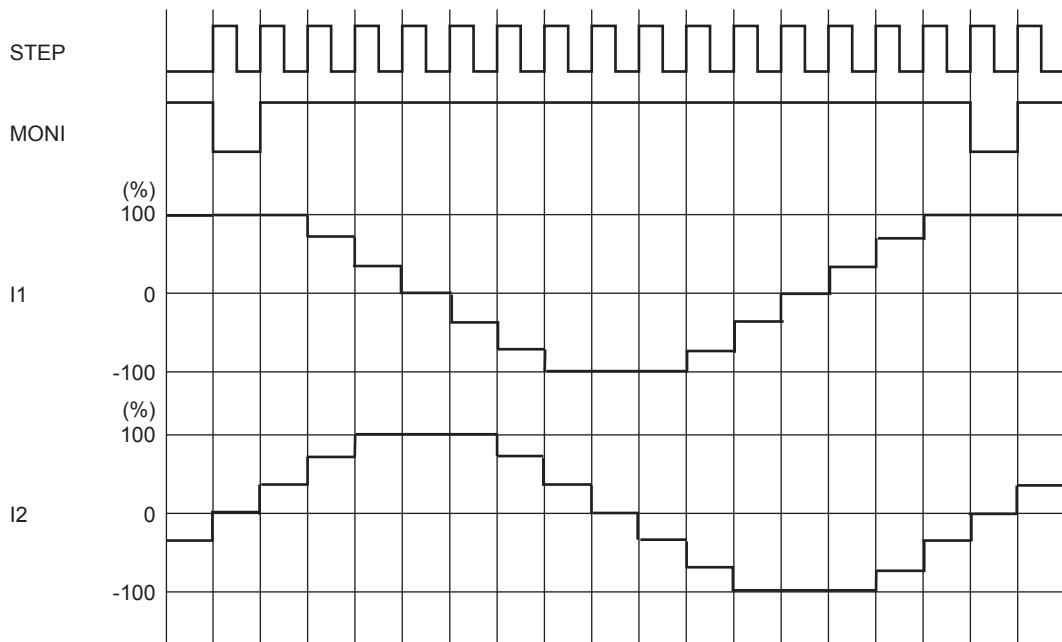

2-12) Current control operation specification
(Sine wave increasing direction)

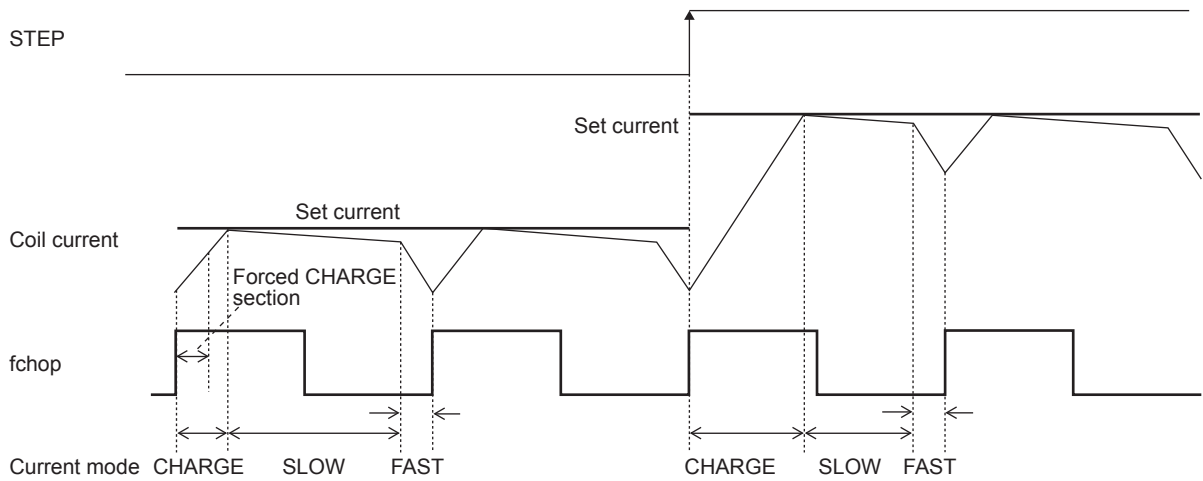

(Sine wave decreasing direction)

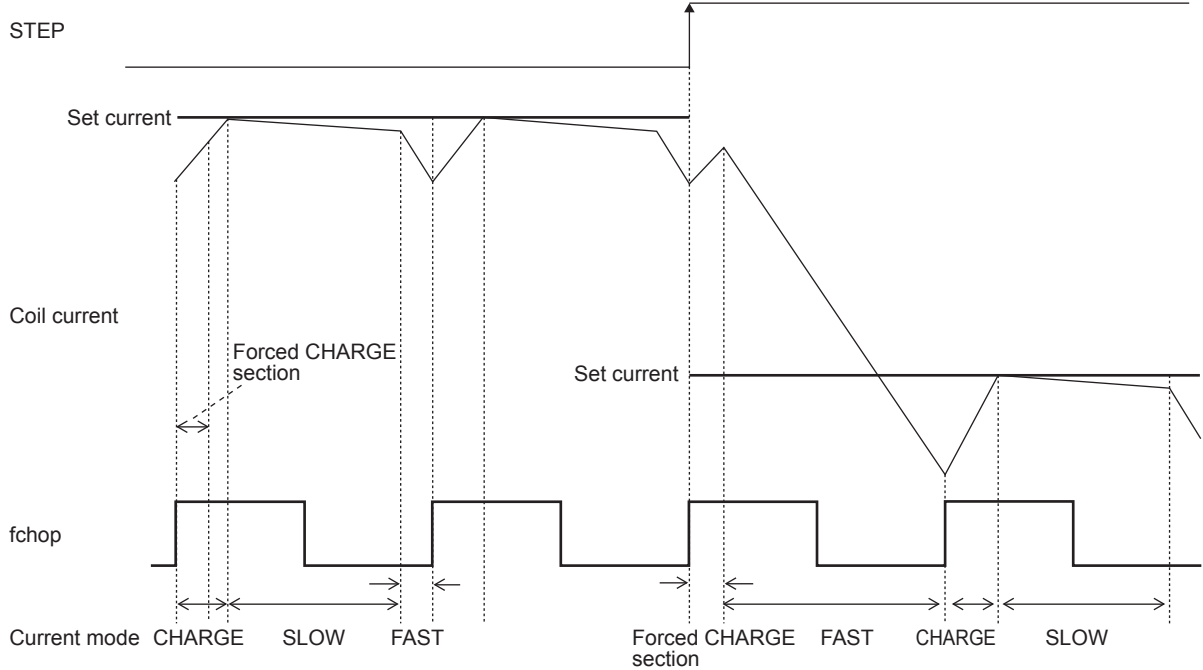

In each current mode, the operation sequence is as described below :

- At rise of chopping frequency, the CHARGE mode begins.(The section in which the CHARGE mode is forced regardless of the magnitude of the coil current (ICOIL) and set current (IREF) exists for 1/16 of one chopping cycle.)
- The coil current (ICOIL) and set current (IREF) are compared in this forced CHARGE section.

When $(ICOIL < IREF)$ state exists in the forced CHARGE section ;

CHARGE mode up to $ICOIL \geq IREF$, then followed by changeover to the SLOW DECAY mode, and finally by the FAST DECAY mode for the 1/16 portion of one chopping cycle.

When $(ICOIL < IREF)$ state does not exist in the forced CHARGE section;

The FAST DECAY mode begins. The coil current is attenuated in the FAST DECAY mode till one cycle of chopping is over.

Above operations are repeated. Normally, the SLOW (+FAST) DECAY mode continues in the sine wave increasing direction, then entering the FAST DECAY mode till the current is attenuated to the set level and followed by the SLOW DECAY mode.

3.DCM Mode (DM-High)

3-1) DCM mode output control logic

Parallel input		Output		Mode
DC11 (21)	DC12 (22)	OUT1 (2) A	OUT1 (2) B	
Low	Low	OFF	OFF	Standby
High	Low	High	Low	CW (Forward)
Low	High	Low	High	CCW (Reverse)
High	High	Low	Low	Brake

3-2) Reset function

RST	Operating mode	MONI
High or Low	Reset operation not performed	High output

The reset function does not operate in DCM mode. In addition, the MONI output is High, regardless of the RST pin state.

3-3) Output enable function

OE	Operating mode
Low	Output OFF
High	Output ON

When the OE pin is set Low, the output is forced OFF and goes to high impedance. When the OE pin is set High, output conforms to the control logic.

3-4) Current limit control time chart

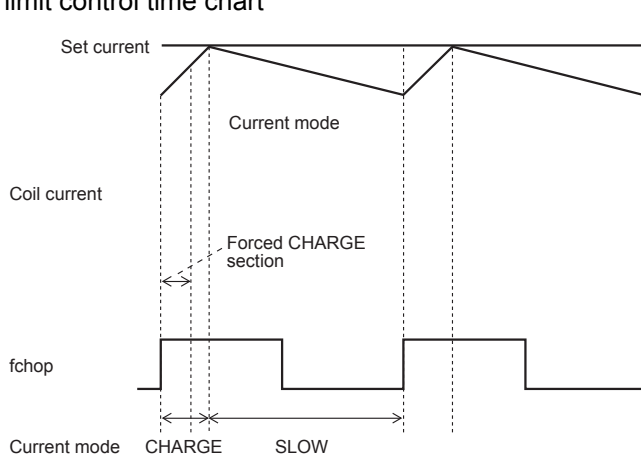

3-5) Current limit reference voltage setting function

ATT1	ATT2	Current setting reference voltage
Low	Low	VREF/3×100%
High	Low	VREF/3×67%
Low	High	VREF/3×50%
High	High	VREF/3×33%

The voltage input to the VREF pin can be switched to four-step settings as the reference voltage for setting the current limit.

Set current calculation method

The reference voltage is set by the voltage applied to the VREF pin and the two inputs ATT1 and ATT2. The current limit can be set from this reference voltage and the RF resistance value.

$$I_{limit} = (VREF/3 \times \text{Current setting ratio}) / R_F \text{ resistance}$$

(Example) When VREF = 0.66V, setting current ratio = 100% [(ATT1, ATT2) = (Low, Low)] and RNF1 (2) = 0.22Ω, the current limit value is as follows :

$$I_{limit} = 0.66V/3 \times 100\%/0.22\Omega = 1A$$

3-6) Examples of current waveform in each micro-step mode when stepper motor parallel input control
Full step (CW mode)

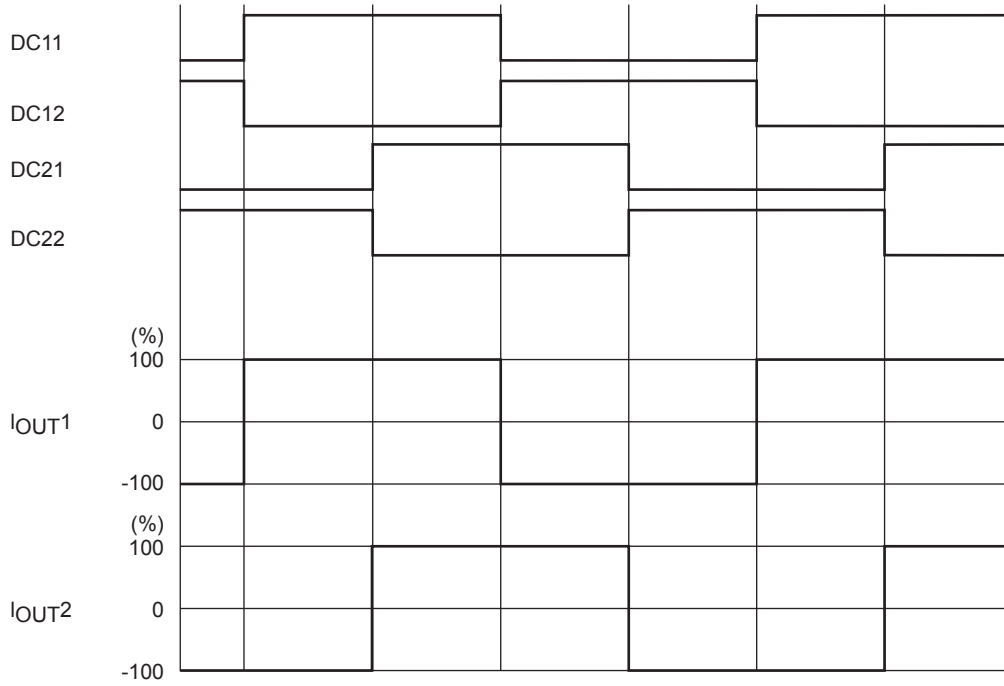

Half step full torque (CW mode)

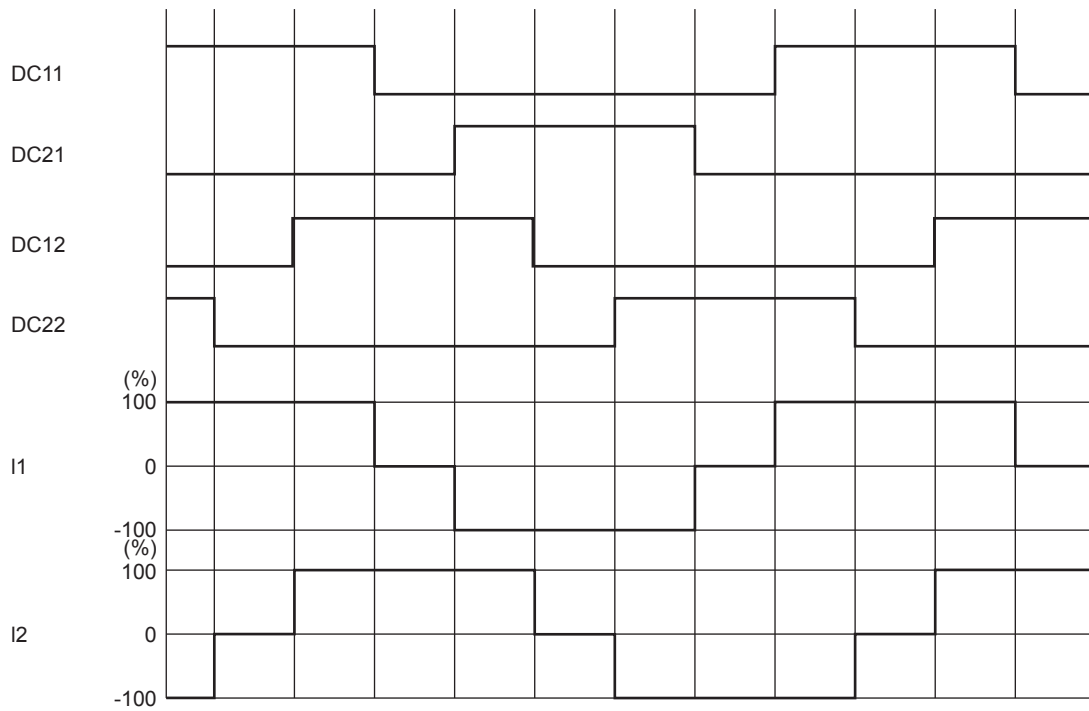

4. Output short-circuit protection circuit

To protect the IC from damage due to short-circuit of the output caused by lightning or ground fault, the output short-circuit protection circuit to put the output in standby mode and turn on the alarm output is incorporated. Note that when the RF pin is short-circuited to GND, this output short-circuit protection is not effective against shorting to power.

4-1) Output short-circuit protection mode switching function

Output short-circuit protection mode of IC can be switched by the setting of EMM pin.

EMM	State
Low or Open	Auto reset method
High	Latch method

4-2) Auto reset method

When the output current is below the output short-circuit protection current, the output is controlled by the input signal. When the output current exceeds the detection current, the switching waveform as shown below appears instead.

(When a 20kΩ resistor is inserted between RCHOP and GND)

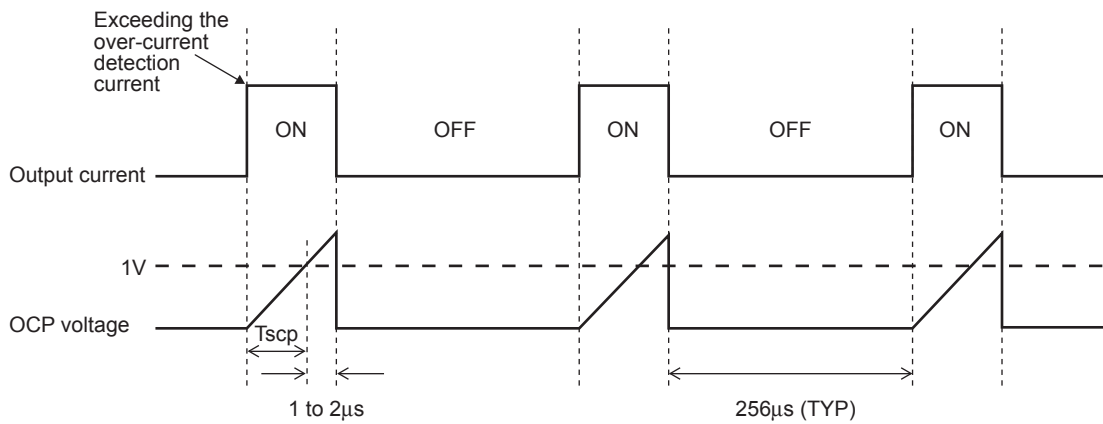

When detecting the output short-circuit state, the short-circuit detection circuit is activated.

When the short-circuit detection circuit operation exceeds the timer latch time described later, the output is changed over to the standby mode and reset to the ON mode again in 256 μs (TYP). In this event, if the overcurrent mode still continues, the above switching mode is repeated till the overcurrent mode is canceled.

4-3) Latch method

Similarly to the case of automatic reset method, the short-circuit detection circuit is activated when it detects the output short-circuit state.

When the short-circuit detection circuit operation exceeds the timer latch time described later, the output is changed over to the standby mode.

In this method, latch is released by setting ST = "L"

4-4) Output short-circuit condition warning output pin

EMO, warning output pin of the output short-circuit protection circuit, is an open-drain output.

EMO outputs ON when output short-circuit is detected.

4-5) Timer latch time (Tscp)

The time to output OFF when an output short-circuit occurs can be set by the capacitor connected between the CEM pin and GND. The capacitor (C) value can be determined as follows :

Timer latch : Tscp

$$T_{scp} \approx T_d + C \times V/I \text{ [sec]}$$

Td : Internal delay time TYP 4μs

V : Threshold voltage of comparator TYP 1V

I : CEM charge current TYP 2.5μA

The Tscp time must be set so as not to exceed 80% of the chopping period.

The CEN pin must be connected to (S) GND when the output short protection function is not to be used.

5. Charge Pump Circuit

When the ST pin is set High, the charge pump circuit operates and the VG pin voltage is boosted from the VM voltage to the VM + VREG5 voltage. If the VG pin voltage is not boosted sufficiently, the output cannot be controlled, so be sure to provide a wait time of tONG or more after setting the ST pin High before starting to drive the motor.

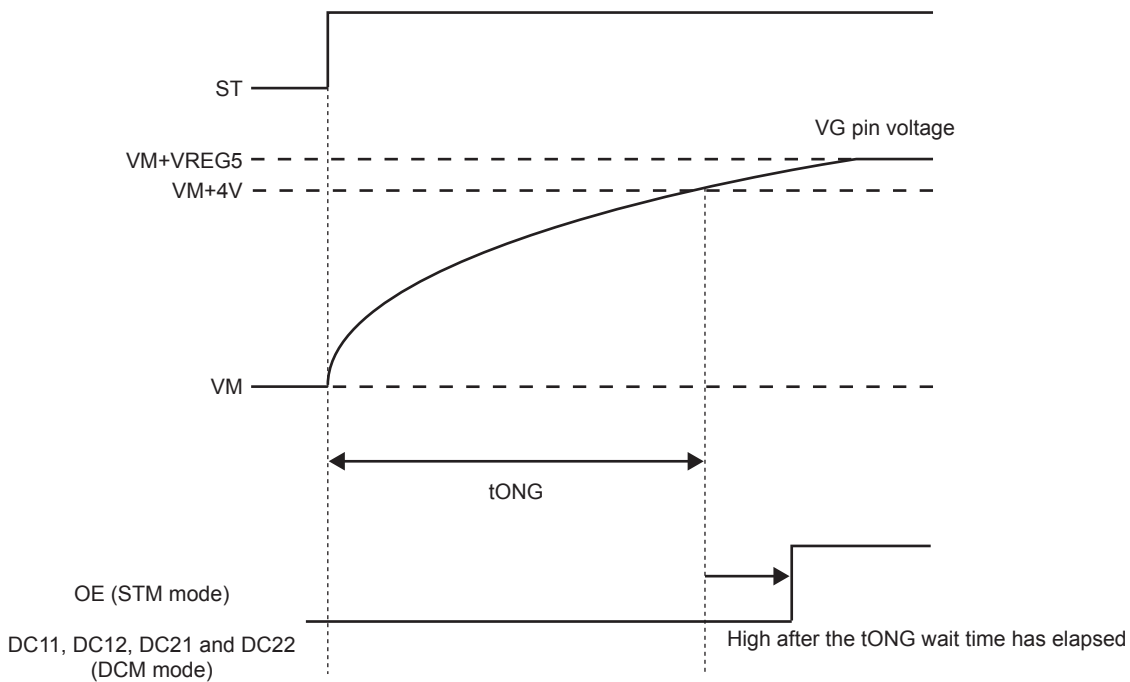

VG Pin Voltage Schematic View

When controlling the stepping motor driver with the CLK-IN input, set the ST pin High, wait for the tONG time duration or longer, and then set the OE pin High. In addition, when controlling the stepping motor and DC motor driver with parallel input, set the ST pin High, wait for the tONG time duration or longer, and then start the control for each channel.

6. Thermal shutdown function

The thermal shutdown circuit is included, and the output is turned off when junction temperature Tj exceeds 180°C and the abnormal state warning output is turned on at the same time.

When the temperature falls hysteresis level, output is driven again (automatic restoration)

The thermal shutdown circuit doesn't guarantee protection of the set and the destruction prevention of IC, because it works at the temperature that is higher than rating (Tjmax=150°C) of the junction temperature

TTSD = 180°C (typ)

ΔTSD = 40°C (typ)

7. Recommended Power-on Sequence

Provide a wait time of 10 μ s or more after the V_{CC} power supply rises before supplying the motor power supply.
Provide a wait time of 10 μ s or more after the motor power supply rises before setting the ST pin High.

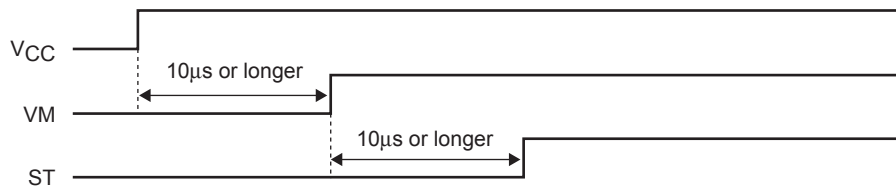

The above power-on sequence is only a recommendation, and there is no risk of damage to the IC even if this sequence is not followed.

Notes on Board Design Layout

- Use thick GND lines and connect to GND stabilization points by the shortest distance possible to lower the impedance.
- Use thick VM, VM1 and VM2 lines, and short-circuit these lines to each other by a short distance.
- Place the capacitors connected to V_{CC} and VM as close to the IC as possible, and connect each capacitor to a separate GND stabilization point using a thick independent line.
- Place the RF resistor as near to the IC as possible, and connect it to the GND stabilization point using a thick independent line.
- When thermal radiation is necessary for the exposed die-pad on the bottom of the IC, solder it to GND. Also, do not connect the exposed die-pad to other than GND.

LV8741V

Application Circuits

- Stepper motor driver application circuit example

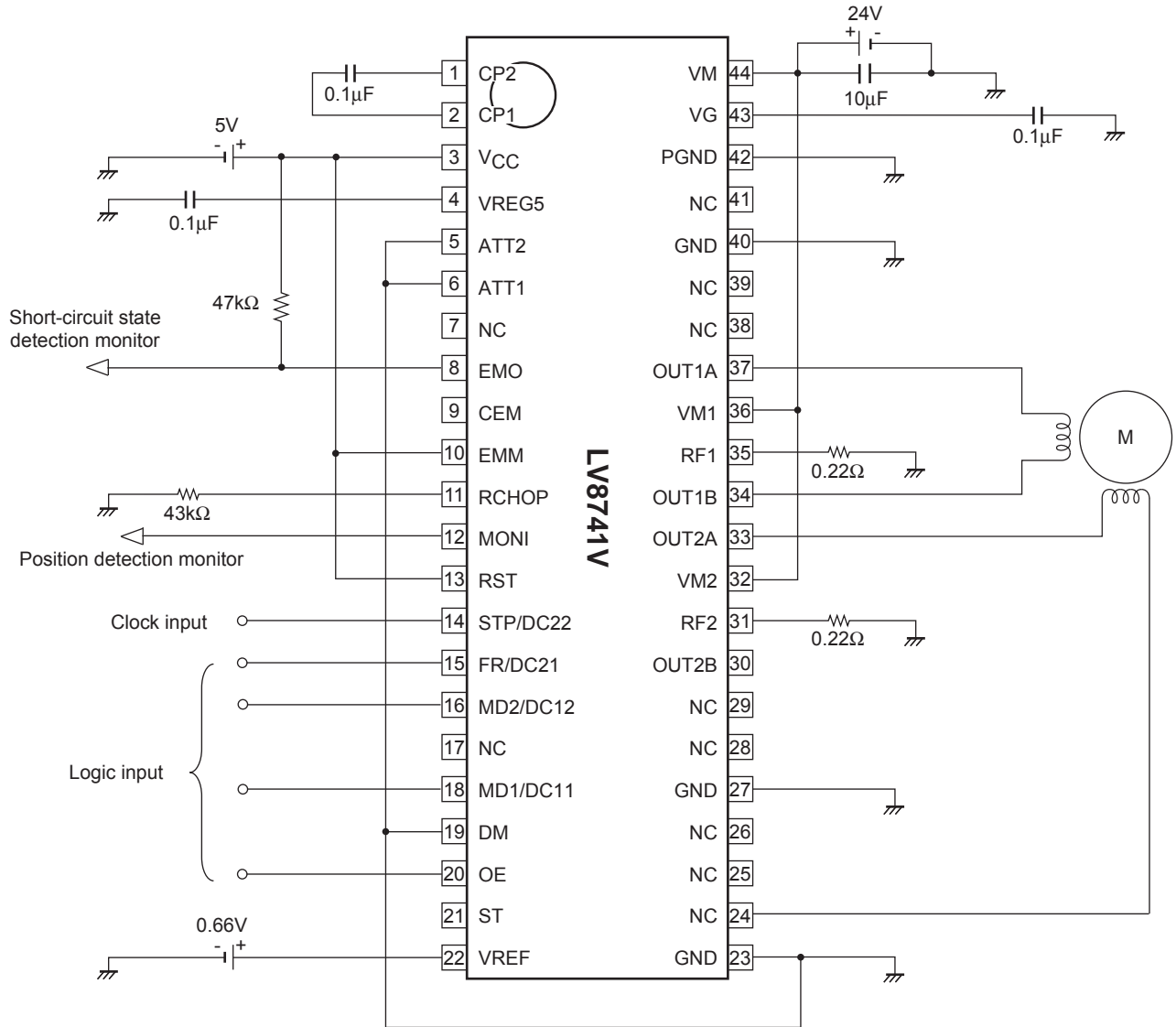

The setting conditions for the above circuit diagram example are as follows :

- Auto recovery-type output short-circuit protection function (EMM = High)
- Reset function fixed to normal operation (RST = High)
- Chopping frequency : 37kHz (RCHOP = 43kΩ)

ATT1	ATT2	Current setting reference voltage
L	L	VREF/3×100%
H	L	VREF/3×67%
L	H	VREF/3×50%
H	H	VREF/3×33%

At the time of VREF = 0.66V, setting electric current ratio 100% [(ATT1, ATT2) =(L,L)], RF resistance 0.22Ω, the set current value is as follows.

$$I_{OUT} = (VREF/3 \times \text{Voltage setting ratio}) / 0.22\Omega$$

$$= (0.66/3 \times 100 \% / 0.22) = 1A$$

LV8741V

- DC motor driver application circuit example

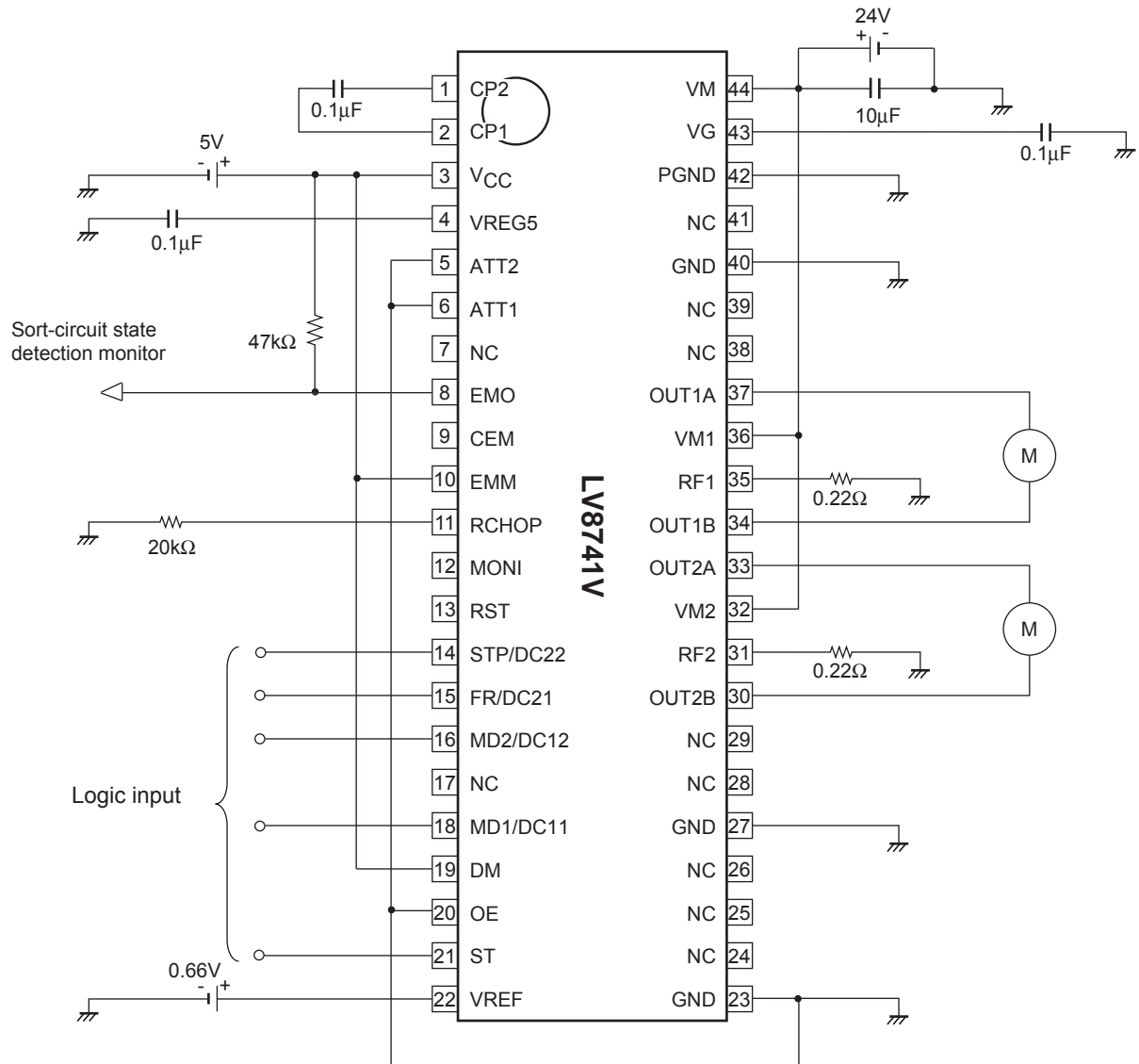

The setting conditions for the above circuit diagram example are as follows :

At the time of $V_{REF} = 0.66V$, setting electric current ratio 100% [(ATT1, ATT2) = (L,L)], R_F resistance 0.22Ω , the current limit value is as follows .

$$I_{OUT} = (V_{REF}/3 \times \text{Voltage setting ratio}) / 0.22\Omega$$

$$= (0.66/3 \times 100 \% / 0.22) = 1A$$

- Auto recovery-type output short-circuit protection function (EMM = High)
- Chopping frequency : 62.5kHz (RCHOP = 20kΩ)

ORDERING INFORMATION

Device	Package	Shipping (Qty / Packing)
LV8741V-TLM-E	SSOP44K (275mil) (Pb-Free)	2000 / Tape & Reel

† For information on tape and reel specifications, including part orientation and tape sizes, please refer to our Tape and Reel Packaging Specifications Brochure, BRD8011/D. http://www.onsemi.com/pub_link/Collateral/BRD8011-D.PDF

ON Semiconductor and the ON logo are registered trademarks of Semiconductor Components Industries, LLC (SCILLC) or its subsidiaries in the United States and/or other countries. SCILLC owns the rights to a number of patents, trademarks, copyrights, trade secrets, and other intellectual property. A listing of SCILLC's product/patent coverage may be accessed at www.onsemi.com/site/pdf/Patent-Marking.pdf. SCILLC reserves the right to make changes without further notice to any products herein. SCILLC makes no warranty, representation or guarantee regarding the suitability of its products for any particular purpose, nor does SCILLC assume any liability arising out of the application or use of any product or circuit, and specifically disclaims any and all liability, including without limitation special, consequential or incidental damages. "Typical" parameters which may be provided in SCILLC data sheets and/or specifications can and do vary in different applications and actual performance may vary over time. All operating parameters, including "Typicals" must be validated for each customer application by customer's technical experts. SCILLC does not convey any license under its patent rights nor the rights of others. SCILLC products are not designed, intended, or authorized for use as components in systems intended for surgical implant into the body, or other applications intended to support or sustain life, or for any other application in which the failure of the SCILLC product could create a situation where personal injury or death may occur. Should Buyer purchase or use SCILLC products for any such unintended or unauthorized application, Buyer shall indemnify and hold SCILLC and its officers, employees, subsidiaries, affiliates, and distributors harmless against all claims, costs, damages, and expenses, and reasonable attorney fees arising out of, directly or indirectly, any claim of personal injury or death associated with such unintended or unauthorized use, even if such claim alleges that SCILLC was negligent regarding the design or manufacture of the part. SCILLC is an Equal Opportunity/Affirmative Action Employer. This literature is subject to all applicable copyright laws and is not for resale in any manner.

X-ON Electronics

Largest Supplier of Electrical and Electronic Components

Click to view similar products for [Motor/Motion/Ignition Controllers & Drivers](#) category:

Click to view products by [ON Semiconductor](#) manufacturer:

Other Similar products are found below :

[FSB50550TB2](#) [FSBF15CH60BTH](#) [MSVCPM2-63-12](#) [MSVGW45-14-2](#) [MSVGW54-14-3](#) [MSVGW54-14-5](#) [NTE7043](#) [LA6565VR-TLM-E](#)
[LB11650-E](#) [LB1837M-TLM-E](#) [LB1845DAZ-XE](#) [LC898300XA-MH](#) [SS30-TE-L-E](#) [26700](#) [BA5839FP-E2](#) [IRAM236-1067A](#) [LA6584JA-AH](#)
[LB11847L-E](#) [NCV70501DW002R2G](#) [AH293-PL-B](#) [STK672-630CN-E](#) [TND315S-TL-2H](#) [FNA23060](#) [FSB50250AB](#) [FNA41060](#) [MSVB54](#)
[MSVBTC50E](#) [MSVCPM3-54-12](#) [MSVCPM3-63-12](#) [MSVCPM4-63-12](#) [MSVTA120](#) [FSB50550AB](#) [NCV70501DW002G](#) [LC898301XA-MH](#)
[LV8413GP-TE-L-E](#) [MSVGW45-14-3](#) [MSVGW45-14-4](#) [MSVGW45-14-5](#) [MSVGW54-14-4](#) [STK984-091A-E](#) [MP6519GQ-Z](#) [LB11651-E](#)
[IRSM515-025DA4](#) [LV8127T-TLM-H](#) [MC33812EKR2](#) [NCP81382MNTXG](#) [TDA21801](#) [LB11851FA-BH](#) [NCV70627DQ001R2G](#)
[LB1938FAGEVB](#)