



ON Semiconductor®

<http://onsemi.com>

# LV8773

Bi-CMOS LSI

## PWM Constant-Current Control Stepping Motor Driver

### Overview

The LV8773 is a 2-channel H-bridge driver IC, which supports forward, reverse, brake, and standby of a motor. It is ideally suited for driving brushed DC motors and stepping motors used in office equipment and amusement applications.

### Features

- BiCDMOS process IC
- Low on resistance (upper side : 0.3Ω ; lower side : 0.25Ω ; total of upper and lower : 0.55Ω ; Ta = 25°C, IO = 2A)
- Motor current selectable in two steps
- Output short-circuit protection circuit (selectable from latch-type or auto-reset-type) incorporated
- Unusual condition warning output pins
- No control power supply required

### Specifications

#### Absolute Maximum Ratings at Ta = 25°C

Parameter	Symbol	Conditions	Ratings	Unit
Supply voltage	VM max		36	V
Output peak current	IO peak	tw ≤ 10ms, duty 20%	2.5	A
Output current	IO max		2	A
Logic input voltage	VIN		-0.3 to +6	V
EMO1/EMO2 input voltage	Vemo/Vemo2		-0.3 to +6	V
Allowable power dissipation	Pd max1	1 unit	3.0	W
	Pd max2	*	6.2	W
Operating temperature	Topr		-20 to +85	°C
Storage temperature	Tstg		-55 to +150	°C

\* Specified circuit board : 90.0mm×90.0mm×1.6mm, glass epoxy 2-layer board.

Stresses exceeding Maximum Ratings may damage the device. Maximum Ratings are stress ratings only. Functional operation above the Recommended Operating Conditions is not implied. Extended exposure to stresses above the Recommended Operating Conditions may affect device reliability.

# LV8773

## Allowable Operating Ratings at $T_a = 25^\circ\text{C}$

Parameter	Symbol	Conditions	Ratings	Unit
Supply voltage range	VM		9 to 32	V
Logic input voltage	$V_{IN}$		0 to 5.5	V
VREF input voltage range	VREF		0 to 3	V

## Electrical Characteristics at $T_a = 25^\circ\text{C}$ , VM = 24V, VREF = 1.5V

Parameter	Symbol	Conditions	Ratings			Unit
			min	typ	max	
Standby mode current drain	IMst	ST = "L"		100	400	$\mu\text{A}$
Current drain	IM	ST = "H", OE = "L", with no load		3.2	5	mA
VREG5 output voltage	Vreg5	$I_O = -1\text{mA}$	4.5	5	5.5	V
Thermal shutdown temperature	TSD	Design guarantee	150	180	200	$^\circ\text{C}$
Thermal hysteresis width	$\Delta\text{TSD}$	Design guarantee		40		$^\circ\text{C}$
<b>Motor driver</b>						
Output on resistance	Ronu	$I_O = 2\text{A}$ , Upper-side on resistance		0.3	0.4	$\Omega$
	Rond	$I_O = 2\text{A}$ , Lower-side on resistance		0.25	0.33	$\Omega$
Output leakage current	$I_{O\text{leak}}$				50	$\mu\text{A}$
Diode forward voltage	VD	$I_D = -2\text{A}$		1.2	1.4	V
Logic pin input current	$I_{INL}$	$V_{IN} = 0.8\text{V}$	4	8	12	$\mu\text{A}$
	$I_{INH}$	$V_{IN} = 5\text{V}$	30	50	70	$\mu\text{A}$
Logic high-level input voltage	$V_{INH}$		2.0			V
Logic low-level input voltage	$V_{INL}$				0.8	V
Current setting comparator threshold voltage (current attenuation rate switching)	Vtatt0	ATT = L	0.291	0.3	0.309	V
	Vtatt1	ATT = H	0.143	0.15	0.157	V
Chopping frequency	Fchop	Cchop = 220pF	36.3	45.4	54.5	kHz
CHOP pin charge/discharge current	Ichop		7	10	13	$\mu\text{A}$
Chopping oscillation circuit threshold voltage	Vtup		0.8	1	1.2	V
	Vtdown		0.4	0.5	0.6	V
VREF pin input current	Iref	VREF = 1.5V	-0.5			$\mu\text{A}$
<b>Charge pump</b>						
VG output voltage	VG		28	28.7	29.8	V
Rise time	tONG	VG = 0.1 $\mu\text{F}$		200		$\mu\text{s}$
Oscillator frequency	Fosc		90	125	150	kHz
<b>Output short-circuit protection</b>						
EMO1/EMO2 pin saturation voltage	Vsatemo	Iemo = 1mA			400	mV
CEM pin charge current	Icem	Vcem = 0V	7	10	13	$\mu\text{A}$
CEM pin threshold voltage	Vtcem		0.8	1	1.2	V

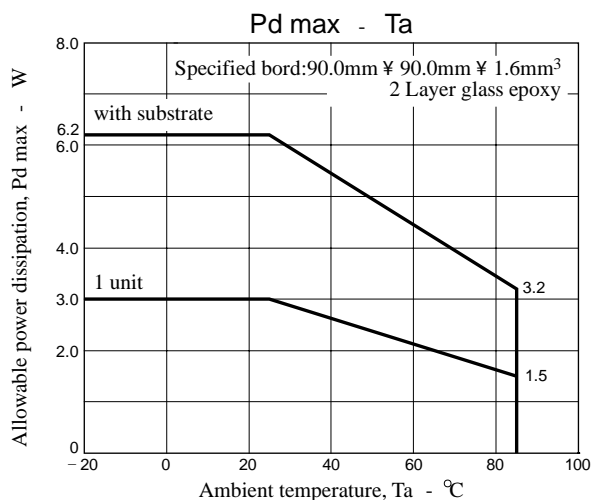

# LV8773

## Package Dimensions

unit : mm (typ)

3241A

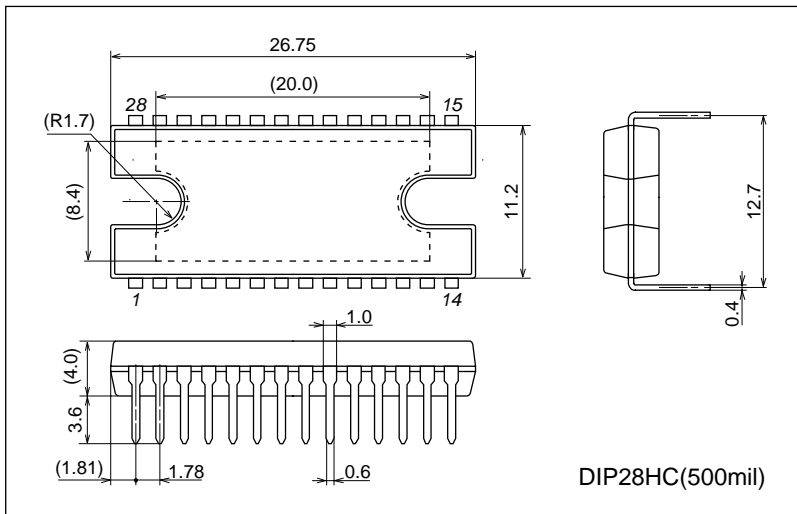

## Pin Assignment

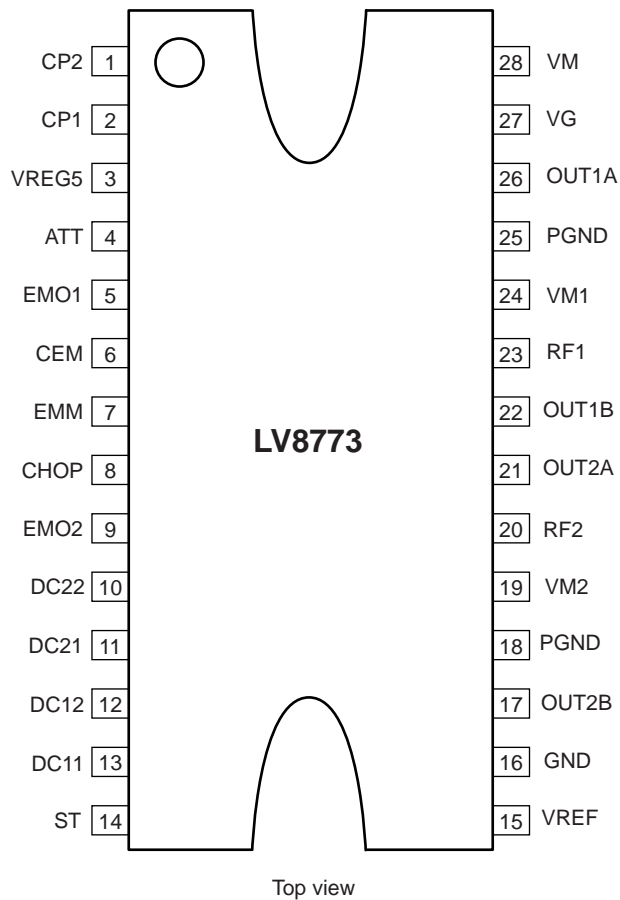

Block Diagram

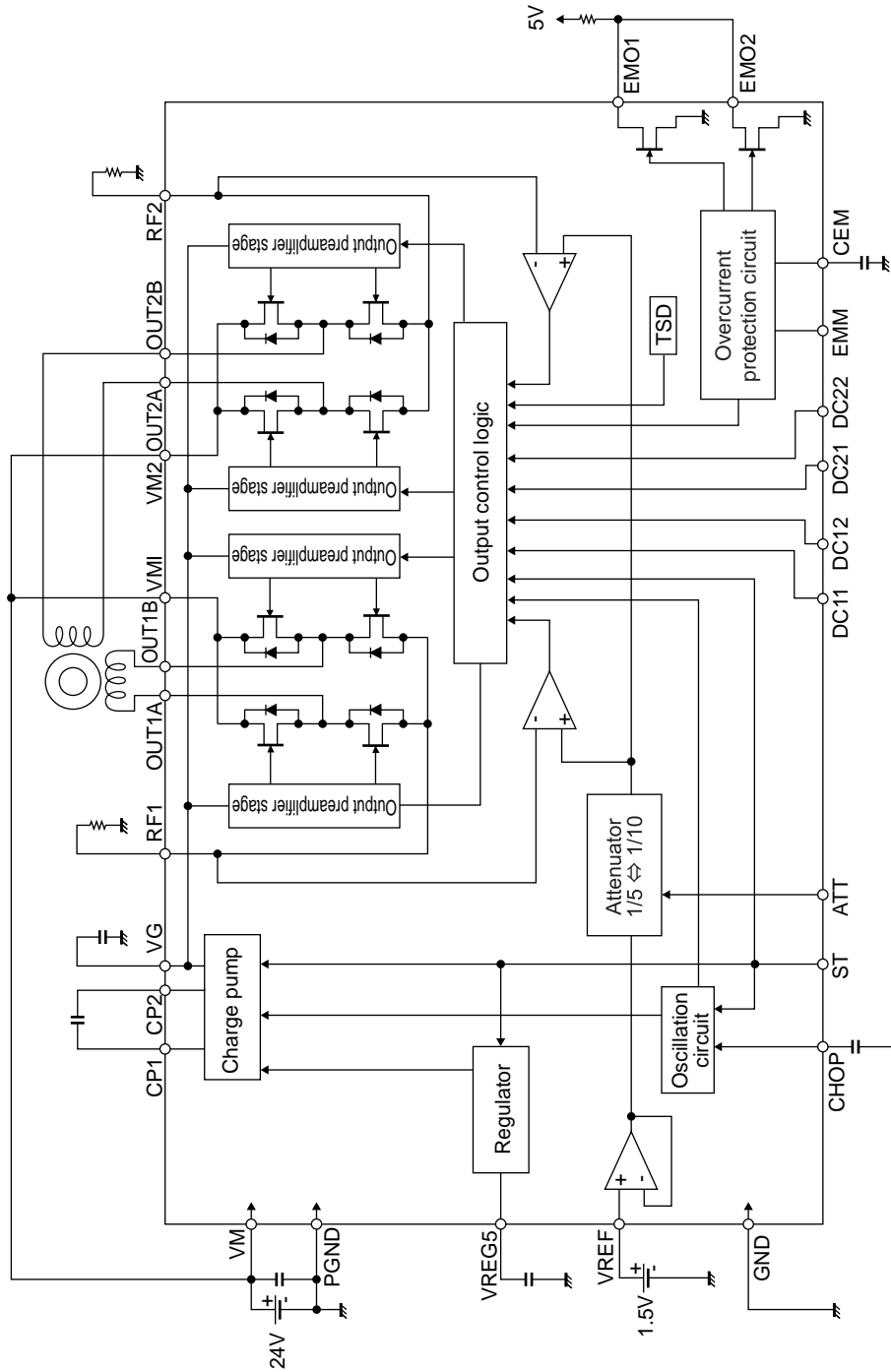

# LV8773

## Pin Functions

Pin No.	Pin Name	Pin Function	Equivalent Circuit
4 7 10 11 12 13	ATT2 EMM DC22 DC21 DC12 DC11	Motor holding current switching pin. Output short-circuit protection mode switching pin. Channel 2 output control input pin 2 Channel 2 output control input pin 1 Channel 1 output control input pin 2 Channel 1 output control input pin 1	
14	ST	Chip enable pin.	
17 18, 25 19 20 21 22 23 24 26	OUT2B PGND VM2 RF2 OUT2A OUT1B RF1 VM1 OUT1A	Channel 2 OUTB output pin. Power system ground. Channel 2 motor power supply connection pin. Channel 2 current-sense resistor connection pin. Channel 2 OUTA output pin. Channel 1 OUTB output pin. Channel 1 current-sense resistor connection pin. Channel 1 motor power supply pin. Channel 1 OUTA output pin.	
27 28 1 2	VG VM CP2 CP1	Charge pump capacitor connection pin. Motor power supply connection pin. Charge pump capacitor connection pin. Charge pump capacitor connection pin.	
16	GND	Ground.	

Continued on next page.

# LV8773

Continued from preceding page.

Pin No.	Pin Name	Pin Function	Equivalent Circuit
15	VREF	Constant current control reference voltage input pin.	
3	VREG5	Internal power supply capacitor connection pin.	
5 9	EMO1 EMO2	Channel 1 output short-circuit state warning output pin. Channel 2 output short-circuit state warning output pin.	
6	CEM	Pin to connect the output short-circuit state detection time setting capacitor	
8	CHOP	Copping frequency setting capacitor connection pin.	

**Description of operation**

**(1) Chip enable function**

This IC is switched between standby and operating mode by setting the ST pin. In standby mode, the IC is set to power-save mode and all logic is reset. In addition, the internal regulator circuit and charge pump circuit do not operate in standby mode.

ST	Mode	Internal regulator	Charge pump
Low or Open	Standby mode	Standby	Standby
High	Operating mode	Operating	Operating

**(2) Output control logic**

input		output		mode
DC11(21)	DC12(22)	OUT1(2)A	OUT1(2)B	
L	L	OFF	OFF	Stand-by
H	L	H	L	CW ( Forward )
L	H	L	H	CCW ( reverse )
H	H	L	L	brake

**(3) Blanking period**

If, when exercising PWM constant-current chopping control over the motor current, the mode is switched from decay to charge, the recovery current of the parasitic diode may flow to the current sensing resistance, causing noise to be carried on the current sensing resistance pin, and this may result in erroneous detection. To prevent this erroneous detection, a blanking period is provided to prevent the noise occurring during mode switching from being received. During this period, the mode is not switched from charge to decay even if noise is carried on the current sensing resistance pin.

This IC is the blanking time is fixed at approximately 2μs.

**(4) Chopping frequency setting**

For constant-current control, this IC performs chopping operations at the frequency determined by the capacitor (Cchop) connected between the CHOP pin and GND.

The chopping frequency is set as shown below by the capacitor (Cchop) connected between the CHOP pin and GND.

$$F_{chop} = I_{chop} / (C_{chop} \times V_{tchop} \times 2) \text{ (Hz)}$$

$I_{chop}$  : Capacitor charge/discharge current, typ 10μA

$V_{tchop}$  : Charge/discharge hysteresis voltage ( $V_{tup} - V_{tdown}$ ), typ 0.5V

For instance, when Cchop is 220pF, the chopping frequency will be as follows :

$$F_{chop} = 10\mu A / (220pF \times 0.5V \times 2) = 45.4kHz$$

(5) Setting constant-current control

When the current of the motor reaches up to a set current by setting the output current, this IC does the short brake control by the automatic operation so that the current should not increase more than it.

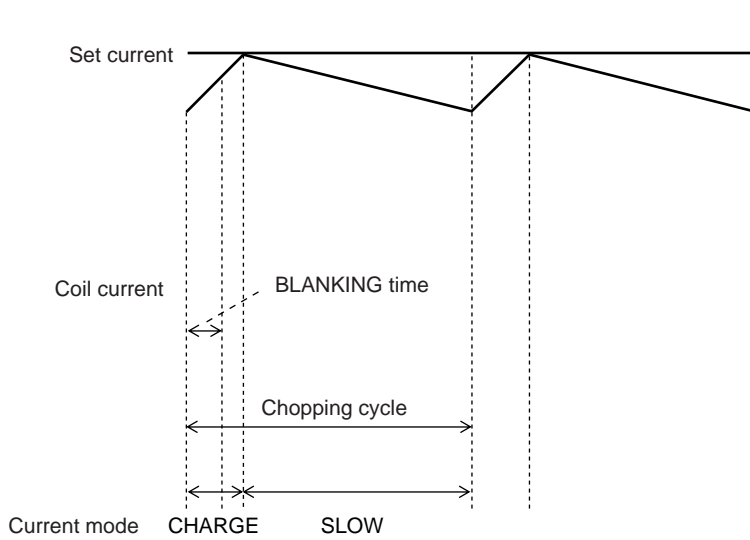

Based on the voltage input to the VREF pin and the resistance connected between RF and GND, the output current that is subject to the constant-current control is set using the calculation formula below :

$$I_{OUT} = (VREF/5)/RF \text{ resistance}$$

\* The above setting is the output current at 100% of each excitation mode.

The voltage input to the VREF pin can be switched to two-step settings depending on the statuses of the ATT.

Attenuation function for VREF input voltage

ATT	Current setting reference voltage attenuation ratio
Low	100%
High	50%

The formula used to calculate the output current when using the function for attenuating the VREF input voltage is given below.

$$I_{OUT} = (VREF/5) \times (\text{attenuation ratio})/RF \text{ resistance}$$

Example : At VREF of 1.5V, a reference voltage setting of 100% (ATT = L) and an RF resistance of 0.3Ω, the output current is set as shown below.

$$I_{OUT} = 1.5V/5 \times 100\%/0.3\Omega = 1.0A$$

If, in this state, ATT = H will be as follows :

$$I_{OUT} = 1.0A \times 50\% = 500mA$$



(6) Typical current waveform in each excitation mode when stepping motor parallel input control  
 2-phase excitation (CW mode)

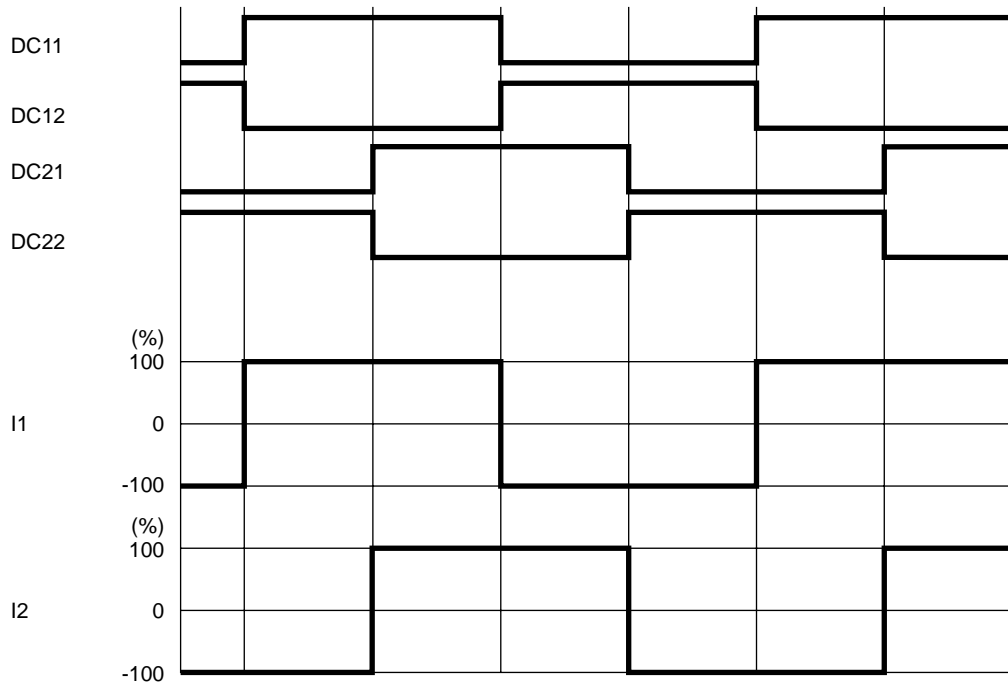

1-2 phase excitation full torque (CW mode)

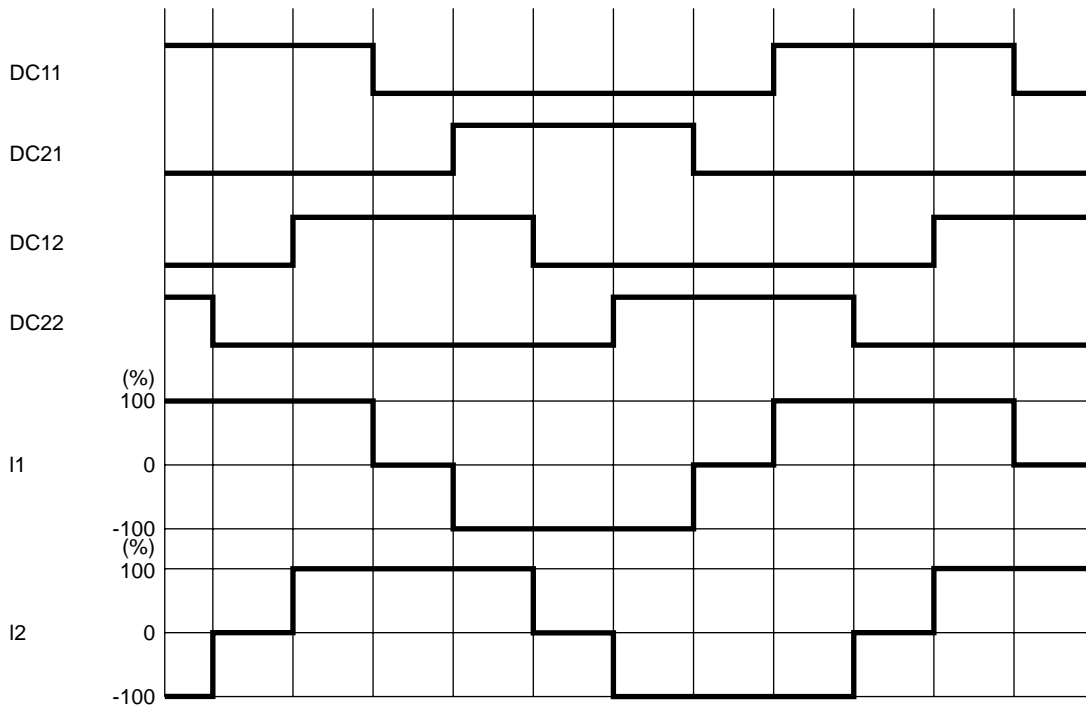

(7) Output short-circuit protection function

This IC incorporates an output short-circuit protection circuit that, when the output has been shorted by an event such as shorting to power or shorting to ground, sets the output to the standby mode and turns on the warning output in order to prevent the IC from being damaged. In the channels 1 and 2 operate independently. (Even if the output of channel 1 has been short-circuited, channel 2 will operate normally.)

(7-1) Output short-circuit protection operation changeover function

Changeover to the output short-circuit protection of IC is made by the setting of EMM pin.

EMM	State
Low or Open	Latch method
High	Auto reset method

(7-2) Latch type

In the latch mode, when the output current exceeds the detection current level, the output is turned OFF, and this state is held.

The detection of the output short-circuited state by the IC causes the output short-circuit protection circuit to be activated.

When the short-circuited state continues for the period of time set using the internal timer (approximately  $2\mu\text{s}$ ), the output in which the short-circuiting has been detected is first set to OFF. After this, the output is set to ON again as soon as the timer latch time ( $T_{cem}$ ) described later has been exceeded, and if the short-circuited state is still detected, all the outputs of the channel concerned are switched to the standby mode, and this state is held.

This state is released by setting ST to low.

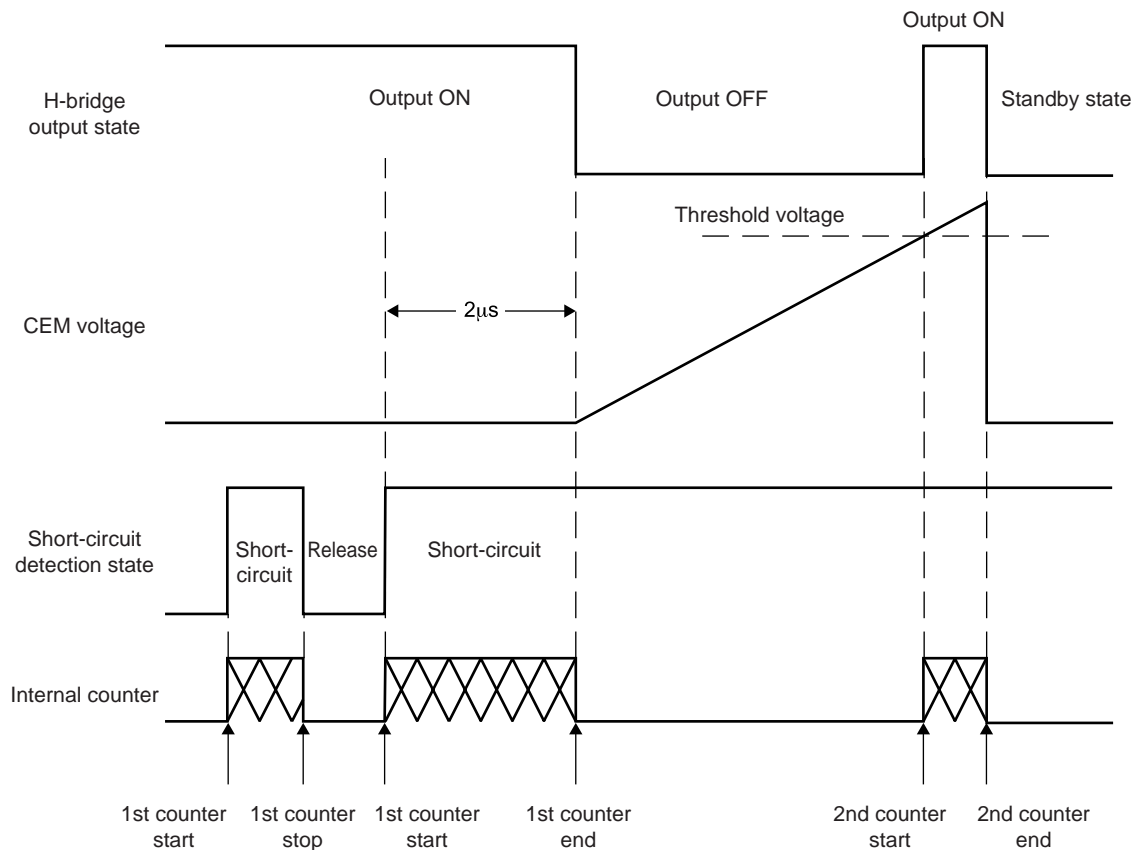



# LV8773

## Application Circuit Example

- Stepping motor driver circuit

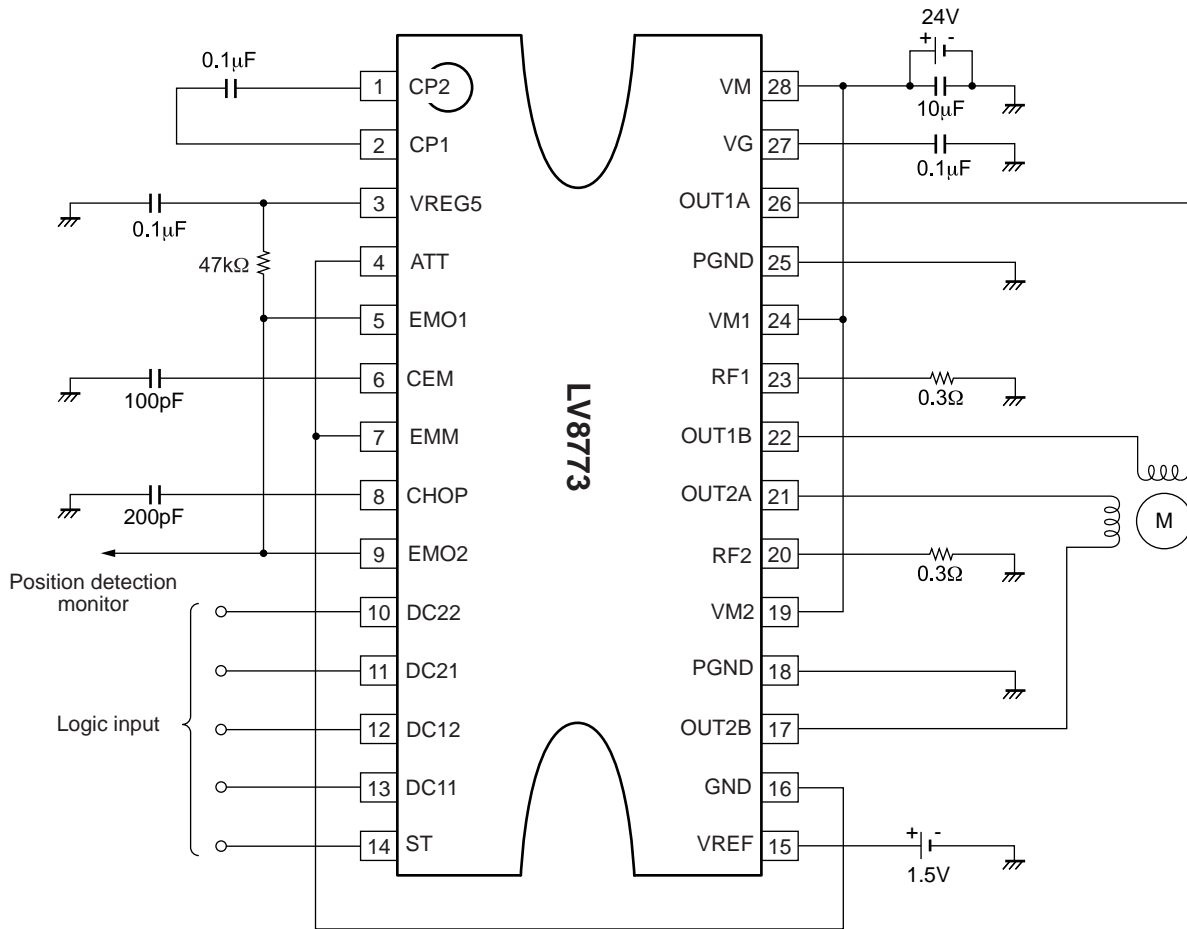

The formulae for setting the constants in the examples of the application circuits above are as follows :

Constant current (100%) setting

When  $V_{REF} = 1.5V$

$$I_{OUT} = V_{REF} / 5 / R_F \text{ resistance} \\ = 1.5V / 5 / 0.3\Omega = 1.0A$$

Chopping frequency setting

$$f_{chop} = I_{chop} / (C_{chop} \times V_{tchop} \times 2) \\ = 10\mu A / (220pF \times 0.5V \times 2) = 45.4kHz$$

Timer latch time when the output is short-circuited

$$T_{cem} = C_{cem} \times V_{tcem} / I_{cem} \\ = 100pF \times 1V / 10\mu A = 10\mu s$$

## LV8773

- DC motor driver circuit (Constant current control function is used.)

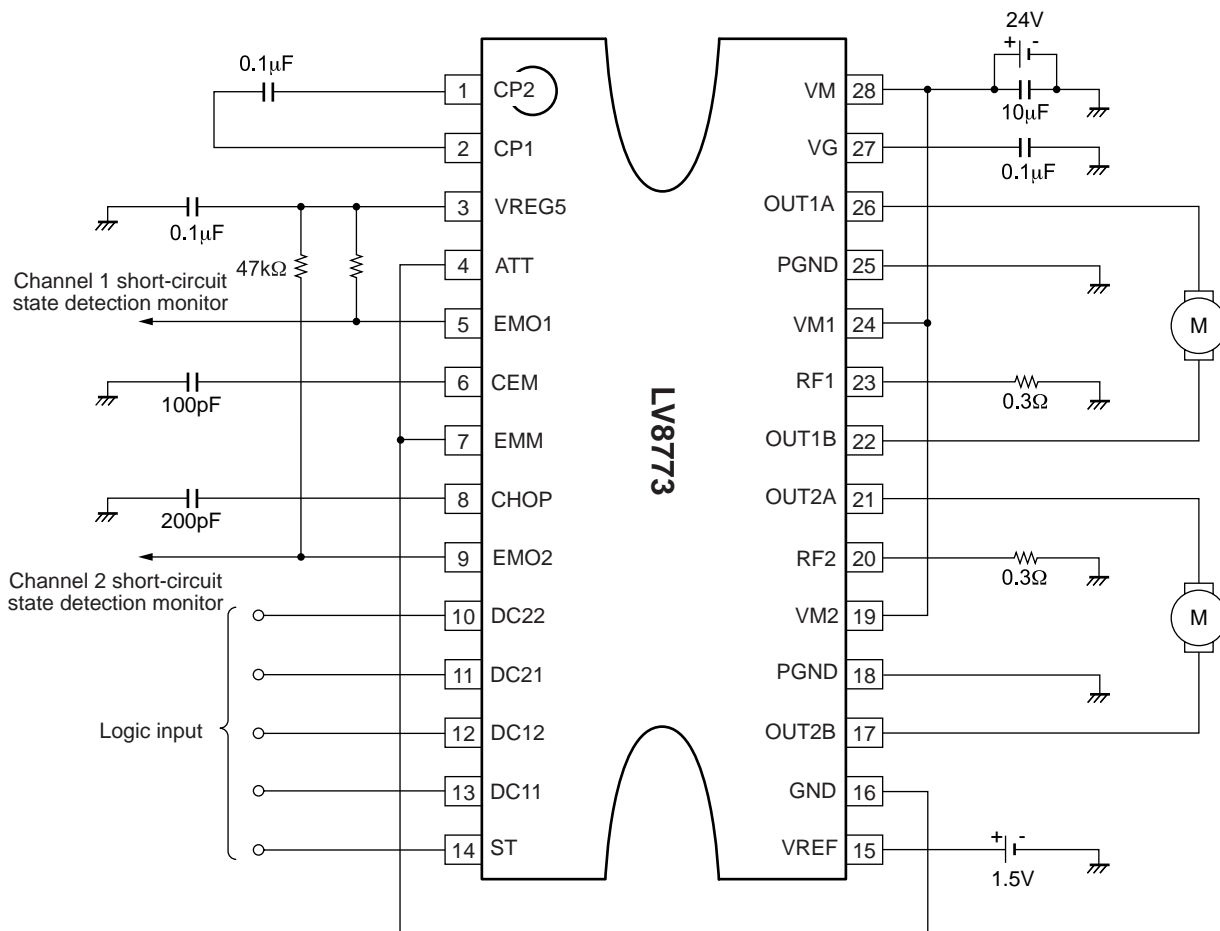

The formulae for setting the constants in the examples of the application circuits above are as follows :

Constant current limit (100%) setting

When  $V_{REF} = 1.5V$

$$I_{limit} = V_{REF} / 5 / R_F \text{ resistance} \\ = 1.5V / 5 / 0.3\Omega = 1.0A$$

Chopping frequency setting

$$F_{chop} = I_{chop} / (C_{chop} \times V_{tchop} \times 2) \\ = 10\mu A / (220pF \times 0.5V \times 2) = 45.4kHz$$

Timer latch time when the output is short-circuited

$$T_{cem} = C_{cem} \times V_{tcem} / I_{cem} \\ = 100pF \times 1V / 10\mu A = 10\mu s$$

ON Semiconductor and the ON logo are registered trademarks of Semiconductor Components Industries, LLC (SCILLC). SCILLC owns the rights to a number of patents, trademarks, copyrights, trade secrets, and other intellectual property. A listing of SCILLC's product/patent coverage may be accessed at [www.onsemi.com/site/pdf/Patent-Marking.pdf](http://www.onsemi.com/site/pdf/Patent-Marking.pdf). SCILLC reserves the right to make changes without further notice to any products herein. SCILLC makes no warranty, representation or guarantee regarding the suitability of its products for any particular purpose, nor does SCILLC assume any liability arising out of the application or use of any product or circuit, and specifically disclaims any and all liability, including without limitation special, consequential or incidental damages. "Typical" parameters which may be provided in SCILLC data sheets and/or specifications can and do vary in different applications and actual performance may vary over time. All operating parameters, including "Typicals" must be validated for each customer application by customer's technical experts. SCILLC does not convey any license under its patent rights nor the rights of others. SCILLC products are not designed, intended, or authorized for use as components in systems intended for surgical implant into the body, or other applications intended to support or sustain life, or for any other application in which the failure of the SCILLC product could create a situation where personal injury or death may occur. Should Buyer purchase or use SCILLC products for any such unintended or unauthorized application, Buyer shall indemnify and hold SCILLC and its officers, employees, subsidiaries, affiliates, and distributors harmless against all claims, costs, damages, and expenses, and reasonable attorney fees arising out of, directly or indirectly, any claim of personal injury or death associated with such unintended or unauthorized use, even if such claim alleges that SCILLC was negligent regarding the design or manufacture of the part. SCILLC is an Equal Opportunity/Affirmative Action Employer. This literature is subject to all applicable copyright laws and is not for resale in any manner.

## X-ON Electronics

Largest Supplier of Electrical and Electronic Components

*Click to view similar products for* [Power Management IC Development Tools](#) *category:*

*Click to view products by* [ON Semiconductor](#) *manufacturer:*

Other Similar products are found below :

[EVAL-ADM1168LQEBZ](#) [EVB-EP5348UI](#) [MIC23451-AAAYFL EV](#) [MIC5281YMME EV](#) [DA9063-EVAL](#) [ADP122-3.3-EVALZ](#) [ADP130-0.8-EVALZ](#) [ADP130-1.2-EVALZ](#) [ADP130-1.5-EVALZ](#) [ADP130-1.8-EVALZ](#) [ADP1712-3.3-EVALZ](#) [ADP1714-3.3-EVALZ](#) [ADP1715-3.3-EVALZ](#) [ADP1716-2.5-EVALZ](#) [ADP1740-1.5-EVALZ](#) [ADP1752-1.5-EVALZ](#) [ADP1828LC-EVALZ](#) [ADP1870-0.3-EVALZ](#) [ADP1871-0.6-EVALZ](#) [ADP1873-0.6-EVALZ](#) [ADP1874-0.3-EVALZ](#) [ADP1882-1.0-EVALZ](#) [ADP199CB-EVALZ](#) [ADP2102-1.25-EVALZ](#) [ADP2102-1.875EVALZ](#) [ADP2102-1.8-EVALZ](#) [ADP2102-2-EVALZ](#) [ADP2102-3-EVALZ](#) [ADP2102-4-EVALZ](#) [ADP2106-1.8-EVALZ](#) [ADP2147CB-110EVALZ](#) [AS3606-DB](#) [BQ24010EVM](#) [BQ24075TEVM](#) [BQ24155EVM](#) [BQ24157EVM-697](#) [BQ24160EVM-742](#) [BQ24296MEVM-655](#) [BQ25010EVM](#) [BQ3055EVM](#) [NCV891330PD50GEVB](#) [ISLUSBI2CKIT1Z](#) [LM2744EVAL](#) [LM2854EVAL](#) [LM3658SD-AEV/NOPB](#) [LM3658SDEV/NOPB](#) [LM3691TL-1.8EV/NOPB](#) [LM4510SDEV/NOPB](#) [LM5033SD-EVAL](#) [LP38512TS-1.8EV](#)