



ON Semiconductor®

<http://onsemi.com>

# LV8804FV

## Bi-CMOS LSI PC and Server Fan Motor Driver

### Overview

The LV8804FV is a motor driver for PC and server fans.

### Feature

- Direct PWM 3-phase sensorless motor driver

### Specifications

#### Absolute Maximum Ratings at $T_a = 25^\circ\text{C}$

Parameter	Symbol	Conditions	Ratings	Unit
$V_{CC}$ maximum supply voltage	$V_{CC\ max}$		16	V
VG maximum supply voltage	$V_{G\ max}$		21	V
OUT pin maximum output current	$I_{OUT\ max}$	UO, VO, and WO pins	1.2	A
SOFTST pin withstand voltage	$V_{SOFTST\ max}$		6	V
FR pin withstand voltage	$V_{FR\ max}$		6	V
CTL pin withstand voltage	$V_{CTL\ max}$		6	V
MINSNP pin withstand voltage	$V_{MINSNP\ max}$		6	V
FG output pin withstand voltage	$V_{FG\ max}$		16	V
FG pin maximum output current	$I_{FG\ max}$		5	mA
Allowable Power dissipation	$P_d\ max1$	Independent IC	0.3	W
	$P_d\ max2$	Mounted on specified board *	0.95	W
Operating temperature	$T_{opr}$		-30 to +95	$^\circ\text{C}$
Storage temperature	$T_{stg}$		-55 to +150	$^\circ\text{C}$

\* Specified board: 76.1mm x 114.3mm x 1.6mm, glass epoxy board (single-layer)

Caution 1) Absolute maximum ratings represent the value which cannot be exceeded for any length of time.

Caution 2) Even when the device is used within the range of absolute maximum ratings, as a result of continuous usage under high temperature, high current, high voltage, or drastic temperature change, the reliability of the IC may be degraded. Please contact us for the further details.

Stresses exceeding Maximum Ratings may damage the device. Maximum Ratings are stress ratings only. Functional operation above the Recommended Operating Conditions is not implied. Extended exposure to stresses above the Recommended Operating Conditions may affect device reliability.

# LV8804FV

## Allowable Operating Conditions at Ta = 25°C

Parameter	Symbol	Conditions	Ratings	Unit
V <sub>CC</sub> supply voltage	V <sub>CC</sub>		6 to 15	V
SOFTST input voltage range	V <sub>SOFTST</sub>		0 to V <sub>REG</sub>	V
FR input voltage range	V <sub>FR</sub>		0 to V <sub>REG</sub>	V
CTL input voltage range	V <sub>CTL</sub>		0 to V <sub>REG</sub>	V
MINSP input voltage range	V <sub>MINSP</sub>		0 to V <sub>REG</sub>	V

## Electrical Characteristics at Ta = 25°C, V<sub>CC</sub> = 12V, unless otherwise specified

Parameter	Symbol	Conditions	Ratings			Unit
			min	typ	max	
Circuit current 1	I <sub>CC1</sub>			3	4	mA
<b>Charge pump block</b>						
Charge pump output voltage	V <sub>VG</sub>			17		V
<b>Regulator block</b>						
5V regulator voltage	V <sub>VREG</sub>		4.75	5	5.25	V
<b>Output on resistance</b>						
High-side output transistor on resistance	R <sub>on (H)</sub>	I <sub>O</sub> = 0.7A, V <sub>G</sub> = 17V		0.6	1.0	Ω
Low-side output transistor on resistance	R <sub>on (L)</sub>	I <sub>O</sub> = 0.7A, V <sub>CC</sub> = 12V		0.6	1.0	Ω
Sum of high-/low-side output transistor on resistance	R <sub>on (H+L)</sub>	I <sub>O</sub> = 0.7A, V <sub>CC</sub> = 12V, V <sub>G</sub> = 17V		1.2	2	Ω
<b>Startup oscillator (OSC) pin</b>						
OSC pin charge current	I <sub>OSCC</sub>			-2.5		μA
OSC pin discharge current	I <sub>OSCD</sub>			2.5		μA
<b>Control voltage input (CTL) pin</b>						
Motor drive on voltage input range	V <sub>CTLON</sub>		0		3	V
Motor drive off voltage input range	V <sub>CTLOFF</sub>		3.5		V <sub>REG</sub>	V
<b>Minimum speed setting pin</b>						
Minimum speed setting voltage input range	V <sub>MINSP1</sub>		1		3	V
Minimum speed releasing voltage input range	V <sub>MINSP2</sub>		4		V <sub>REG</sub>	V
<b>Forward/reverse switching pin</b>						
High-level input voltage range	V <sub>FRH</sub>	Order of current application : U <sub>OUT</sub> →V <sub>OUT</sub> →W <sub>OUT</sub>	4		V <sub>REG</sub>	V
Low-level input voltage range	V <sub>FRL</sub>	Order of current application : U <sub>OUT</sub> →W <sub>OUT</sub> →V <sub>OUT</sub>	0		1	V
<b>FG output pin</b>						
FG output pin low-level voltage	V <sub>FG</sub>	When I <sub>O</sub> is 2mA		0.25	0.35	V
<b>Current limiter circuit</b>						
Limiter voltage	V <sub>RF</sub>	Limit current set to 1A when R <sub>F</sub> is 0.25Ω.	0.225	0.25	0.275	V
<b>Constraint protection circuit</b>						
CT pin high-level voltage	V <sub>CTH</sub>		2.25	2.8	2.95	V
CT pin low-level voltage	V <sub>CTL</sub>		0.43	0.5	0.65	V
CT pin charge current	I <sub>CTC</sub>		-2.9	-2.5	-2.2	μA
CT pin discharge current	I <sub>CTD</sub>		0.23	0.25	0.32	μA
ICT charge/discharge ratio	R <sub>CT</sub>		7	10	13	
<b>Soft start circuit</b>						
Soft start releasing voltage	V <sub>SOFTST</sub>			2.5		V
SOFTST pin charge current	I <sub>SOFTST</sub>			0.6		μA
<b>Thermal protection circuit</b>						
Thermal protection circuit operating temperature	TSD	Design target *	150	180	210	°C

\* : Design target value and no measurement is made. The thermal protection circuit is incorporated to protect the IC from burnout or thermal destruction. Since it operates outside the IC's guaranteed operating range, the customer's thermal design should be performed so that the thermal protection circuit will not be activated when the fan is running under normal operating conditions.

# LV8804FV

## Package Dimensions

unit : mm (typ)  
3360

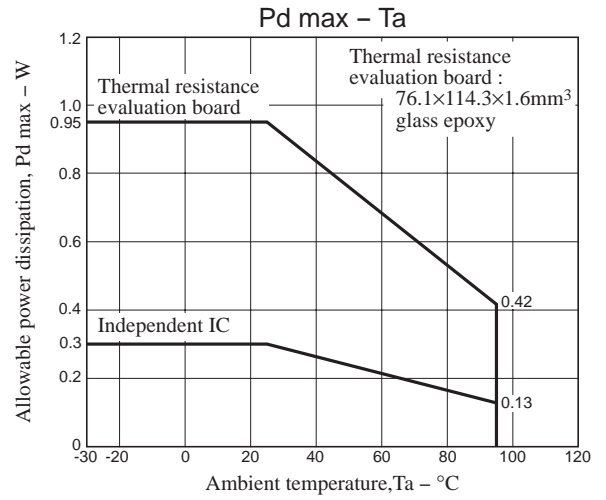
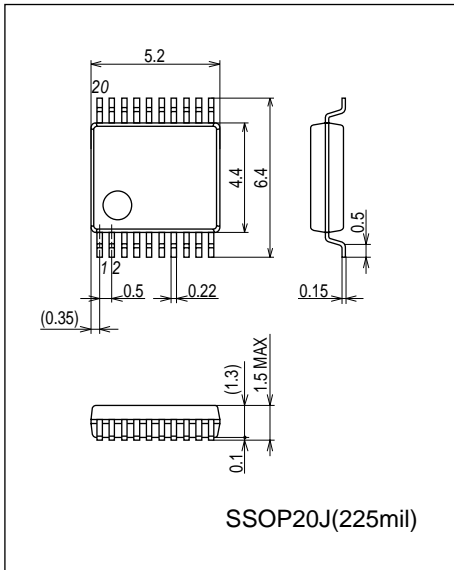

## Pin Assignment

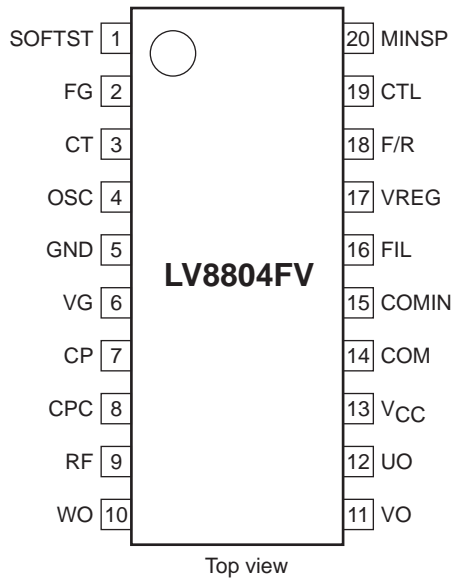

# LV8804FV

## Block Diagram

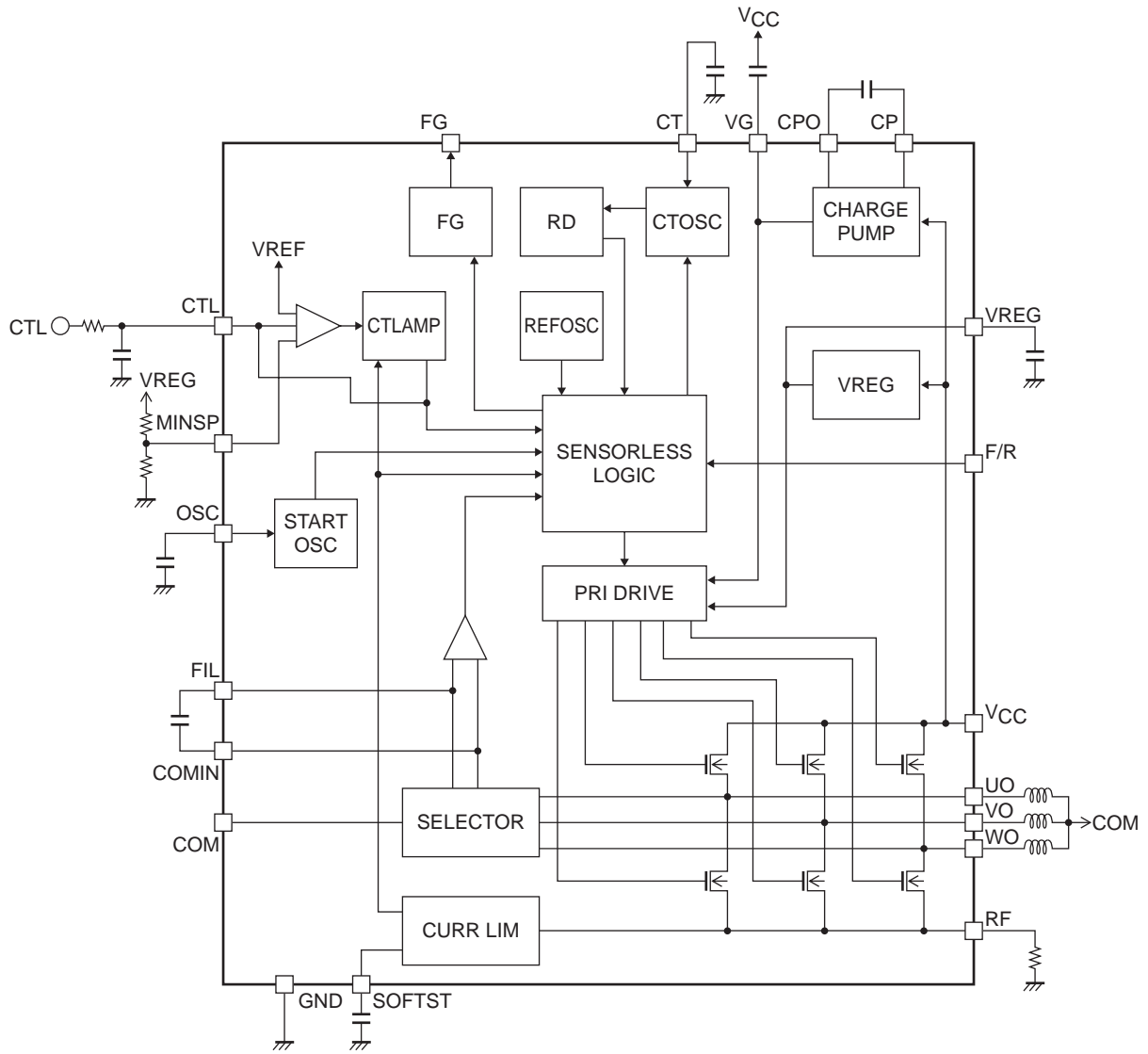

# LV8804FV

## Pin Function

Pin No.	Pin name	Function	Equivalent circuit
1	SOFTST	Soft start time setting. The motor can be started smoothly by connecting a capacitor between this pin and ground.	
2	FG	FG pulse output. This pin outputs a Hall sensor system equivalent pulse signal.	
3	CT	Motor lockup detection time setting. When the motor lockup condition is detected, the protection time period before the protection circuit is activated is set by connecting a capacitor between this pin and ground.	
4	OSC	Motor startup frequency setting. A capacitor must be connected between this pin and ground. The startup frequency is adjusted by controlling the charge/discharge current and capacitance of the capacitor.	
5	GND	GND pin.	
6	VG	Charge pump step-up voltage output. A capacitor must be connected between this pin and the V <sub>CC</sub> pin or ground.	
7	CP	Charge pump step-up pulse output pin. A capacitor must be connected between this pin and the CPC pin (pin 14).	
8	CPC	Charge pump step-up pin. A capacitor must be connected between this pin and the CP pin (pin 13).	
13	V <sub>CC</sub>	Power supply for the IC and motor. Capacitors must be connected between these pins and ground.	
12	UO	Output pins. Connect these pins to the U, V, and W of the motor coil.	
11	VO		
10	WO		
9	RF	Output current detection pins. The drive current is detected by connecting a resistor between these pins and ground.	

Continued on next page.

# LV8804FV

Continued from preceding page.

Pin No.	Pin name	Function	Equivalent circuit
14	COM	Motor middle point connection.	
15	COMIN	Motor position detection comparator filter pin. A capacitor must be connected between this pin and the FIL pin (pin 16).	
16	FIL	Motor position detection comparator filter pin. A capacitor must be connected between this pin and the COMIN pin (pin 15).	
17	VREG	Regulator voltage (5V) output. A capacitor must be connected between these pins and ground.	
18	F/R	Motor rotation direction switching. A high-level input causes current to flow into the motor in the order of U, V, and W and a low-level input in the order of U, W, and V. Changing the order of current application turns the motor in the opposite direction.	
19	CTL	Motor control voltage input. When the control voltage is higher than 3V (3V < CTL voltage), the motor stops. The motor speed is controlled by varying the control voltage within the range of 3V to 1V (3V > CTL voltage > 1V). When the control voltage becomes lower than 1V (1V > CTL voltage), the current limit set by the RF resistor is reached.	
20	MINSP	Minimum speed setting voltage input. The minimum speed of the motor can be set by resistor-dividing the regulator voltage and feeding the resultant voltage that is within the range of 1V to 3V (1V < MINSP < 3V).	

## LV8804FV Functional Description

### 1. Control Characteristics

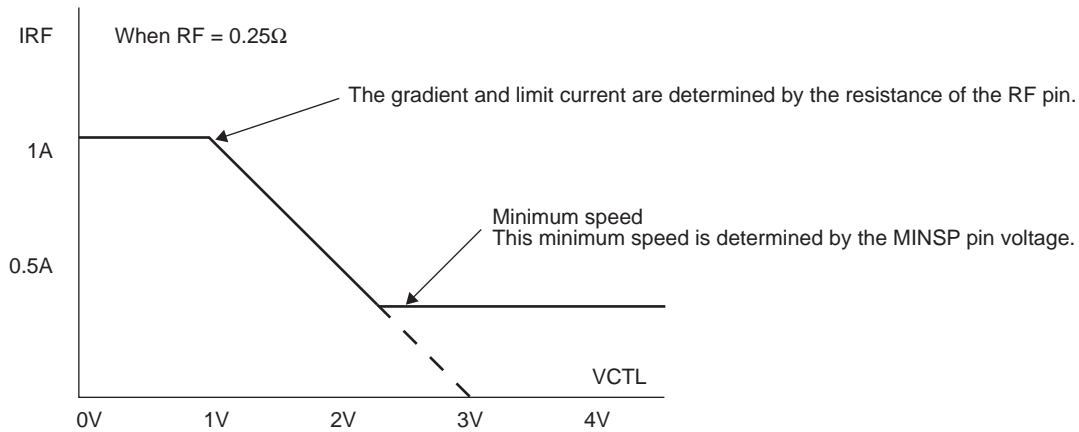

The current flowing to the motor and the control characteristics are determined by adjusting the resistance of the RF resistor.

By connecting a resistor with a resistance of  $0.25\Omega$  between the RF pin and GND, the limit current is set at a motor current of 1A, and the control characteristics shown in the diagram above are achieved.

By increasing the RF resistance, the limit current is reduced; conversely, by reducing the RF resistance, the limit current is increased.

Since  $I_{O\ max.}$  is 1.2A, the RF resistance must be set in such a way that the current flowing to the motor does not exceed this maximum value.

By varying the CTL voltage between 1V and 3V, the current flowing to the output is limited.

PWM control is exercised within the voltage range above (1V to 3V) to control the motor speed.

When the CTL voltage is less than 1V, the current limiter value determined by the RF resistance is reached, and the motor speed is limited.

When the CTL voltage is greater than 3V, PWM is reduced to 0%, and the motor stops. (However, the motor does not stop if the minimum speed has been set.)

The minimum speed can be set by resistor-dividing the REG voltage (5V) to create a voltage of 1V to 3V, and inputting this voltage to the MINSP pin.

If the minimum speed is not going to be set, the MINSP pin and CTL pin (pin 8) must be short-circuited.

### 2. Timing at Startup (soft start)

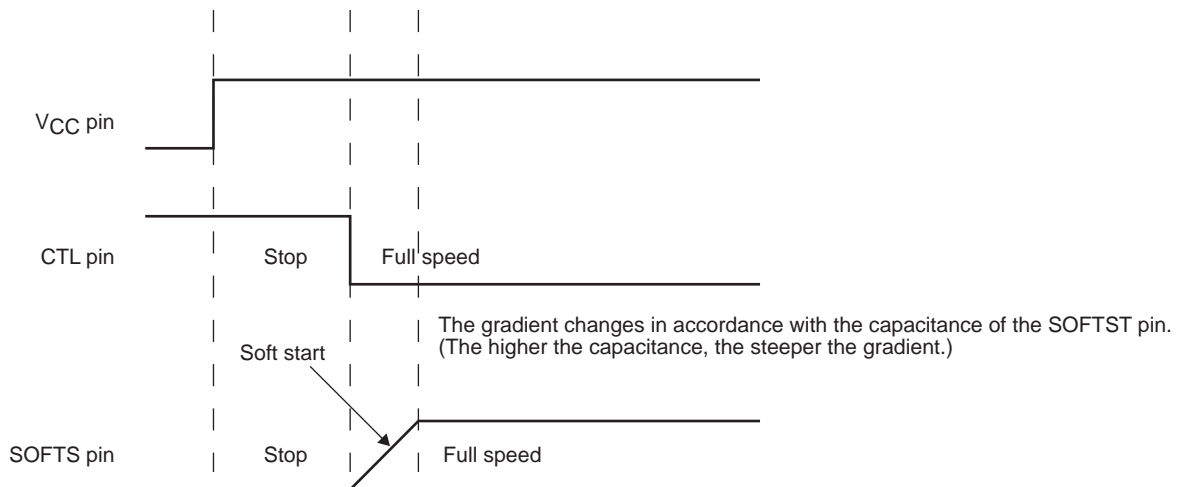

## Application Circuit Example

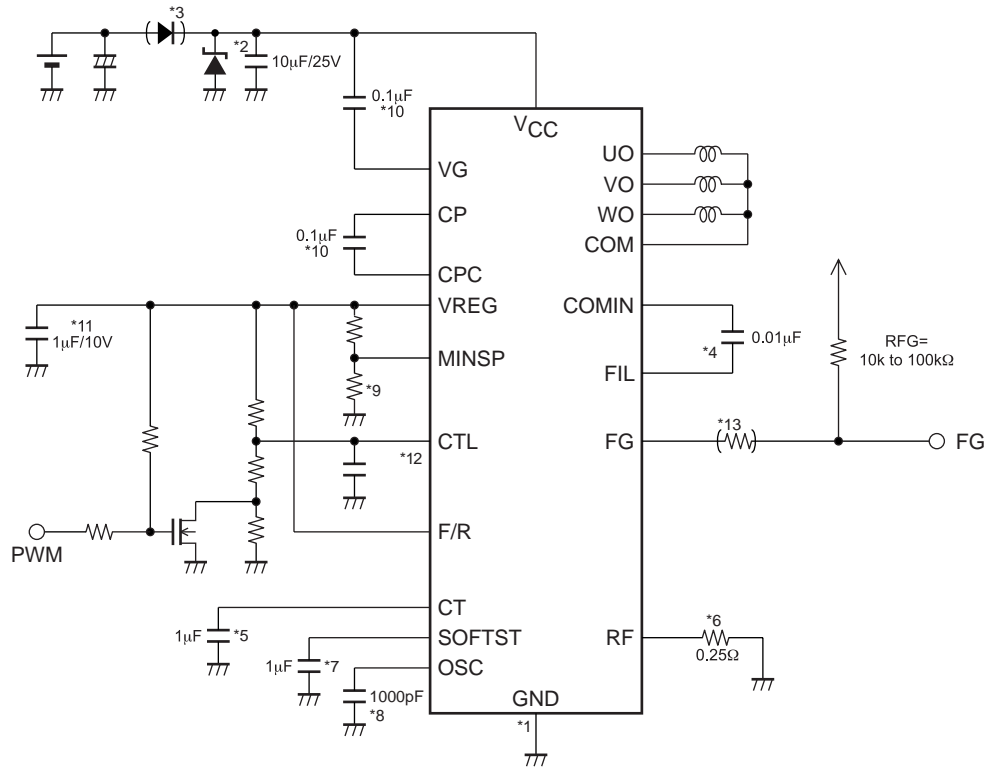

### \*1. Power supply and GND wiring

The GND is connected to the control circuit power supply system.

### \*2. Power-side power stabilization capacitor

For the power-side power stabilization capacitor, use a capacitor of 10µF or more.

Connect the capacitor between VCC and GND with a thick and along the shortest possible route.

LV8804FV uses synchronous rectification for high efficiency drive. Synchronous rectification is effective for heat reduction and higher efficiency. However, it may increase supply voltage.

If the supply voltage shall increase, make sure that it does not exceed the maximum ratings by inserting a zener diode between power supply and GND.

### \*3. Reverse connection protection diode

This diode protects reverse connection.

Insert a diode between power supply and VCC pin to protect the IC from destruction due to reverse connection.

Connection of this diode is not necessary required.

### \*4. COMIN and FIL pins

These pins are used to connect the filter capacitor. The LV8804FV uses the back EMF signal generated when the motor is running to detect the information on the rotor position. The IC determines the timing at which the output block applies current to the motor based on the position information obtained here. Insert a filter capacitor (1,000pF to 10,000pF) between the COMIN pin and FIL pin to prevent any motor startup miss-operation that is caused by noise. However, care must be taken since an excessively high capacitance will give rise to deterioration in efficiency and delays in the output power-on timing while the motor is running at high speed.

Furthermore, connect the capacitor between the COMIN pin and FIL pin as close as possible in order to avoid the effects of noise from other sources.

### \*5. CT pin

This pin is used to connect the lock detection capacitor.

The constant-current charging and constant-current discharging circuits incorporated causes locking when the pin voltage reaches 2.5V, and releasing the lock protection when it drops to 0.5V. This pin must be connected to the GND when it is not going to be used.



### \*6. RF pins

These pins are used to set the current limit.

When the pin voltage exceeds 0.25V, the current is limited, and regeneration mode is established. In the application circuit, this voltage is set in such a way that the current limit will be established at 1A.

The calculation formula is given below.

RF resistance = 0.25V/target current limit value

### \*7. SOFTST pin

This pin is used to set the soft start.

By connecting a capacitor between this pin and GND, the motor speed can be increased gradually.

When the pin voltage exceeds 2.5V, the soft start is released, and the LV8804FV is switched to normal control.

If the soft start function is not going to be used, connect the pin to the VREG pin.

### \*8. OSC pin

This pin is used to connect the capacitor for setting the startup frequency.

A capacitor with a capacitance ranging from about 500pF to 2,200pF (recommended value) must be connected between this pin and GND.

The OSC pin determines the motor startup frequency, so be sure to connect a capacitor to it.

<How to select the capacitance>

Select a capacitance value that will result in the shortest possible startup time for achieving the target speed and produce minimal variations in the startup time. If the capacitance is too high, variations in the startup time will increase; conversely, if it is too low, the motor may idle. The optimum OSC constant depends on the motor characteristics and startup current, so be sure to recheck them when the type of motor used or circuit specifications are changed.

### \*9. MINSP pin

This pin is used to input the voltage to set the minimum speed.

The minimum speed can be set by resistor-dividing the VREG voltage (5V) to create a voltage of 1 to 3V, and inputting this voltage to the MINSP pin.

If the minimum speed is not going to be set, the MINSP pin and CTL pin must be short-circuited.

### \*10. VG, CP, and CPC pins

These pins are used to connect the capacitors to generate the pre-drive voltage and stabilize the pre-drive power supply.

Be sure to connect these capacitors in order to generate the drive voltage for the high-side (upper) output DMOS transistor.

### \*11. VREG pins

These are the control system power supply pin and regulator output pin, which create the power supply of the control unit. Be sure to connect a capacitor between this pin and GND in order to stabilize control system operation.

Since these pins are used to supply current for control and generate the charge pump voltage, connect a capacitor with a capacitance that is higher than that of the capacitor connected to the charge pump.

### \*12. CTL pins

Change by the Slew Rate of 0.5V/ms or more and use the voltage of the CTL pin.

The current might return to the power supply when using it below the above-mentioned Slew Rate and IC be destroyed.

### \*13. Pin protection resistor

It is recommended that resistors higher than 1kΩ are connected serially to protect pins against misconnection such as GND open and reverse connection.

ON Semiconductor and the ON logo are registered trademarks of Semiconductor Components Industries, LLC (SCILLC). SCILLC owns the rights to a number of patents, trademarks, copyrights, trade secrets, and other intellectual property. A listing of SCILLC's product/patent coverage may be accessed at [www.onsemi.com/site/pdf/Patent-Marking.pdf](http://www.onsemi.com/site/pdf/Patent-Marking.pdf). SCILLC reserves the right to make changes without further notice to any products herein. SCILLC makes no warranty, representation or guarantee regarding the suitability of its products for any particular purpose, nor does SCILLC assume any liability arising out of the application or use of any product or circuit, and specifically disclaims any and all liability, including without limitation special, consequential or incidental damages. "Typical" parameters which may be provided in SCILLC data sheets and/or specifications can and do vary in different applications and actual performance may vary over time. All operating parameters, including "Typicals" must be validated for each customer application by customer's technical experts. SCILLC does not convey any license under its patent rights nor the rights of others. SCILLC products are not designed, intended, or authorized for use as components in systems intended for surgical implant into the body, or other applications intended to support or sustain life, or for any other application in which the failure of the SCILLC product could create a situation where personal injury or death may occur. Should Buyer purchase or use SCILLC products for any such unintended or unauthorized application, Buyer shall indemnify and hold SCILLC and its officers, employees, subsidiaries, affiliates, and distributors harmless against all claims, costs, damages, and expenses, and reasonable attorney fees arising out of, directly or indirectly, any claim of personal injury or death associated with such unintended or unauthorized use, even if such claim alleges that SCILLC was negligent regarding the design or manufacture of the part. SCILLC is an Equal Opportunity/Affirmative Action Employer. This literature is subject to all applicable copyright laws and is not for resale in any manner.

## X-ON Electronics

Largest Supplier of Electrical and Electronic Components

*Click to view similar products for [Motor/Motion/Ignition Controllers & Drivers](#) category:*

*Click to view products by [ON Semiconductor](#) manufacturer:*

Other Similar products are found below :

[FSB50550TB2](#) [FSBF15CH60BTH](#) [MSVCPM2-63-12](#) [MSVGW45-14-2](#) [MSVGW54-14-3](#) [MSVGW54-14-5](#) [NTE7043](#) [LA6565VR-TLM-E](#)  
[LB11650-E](#) [LB1837M-TLM-E](#) [LB1845DAZ-XE](#) [LC898300XA-MH](#) [SS30-TE-L-E](#) [26700](#) [LV8281VR-TLM-H](#) [BA5839FP-E2](#) [IRAM236-1067A](#) [LA6584JA-AH](#) [LB11847L-E](#) [NCV70501DW002R2G](#) [AH293-PL-B](#) [STK672-630CN-E](#) [TND315S-TL-2H](#) [FNA23060](#) [FSB50250AB](#)  
[FNA41060](#) [MSVB54](#) [MSVBTC50E](#) [MSVCPM3-54-12](#) [MSVCPM3-63-12](#) [MSVCPM4-63-12](#) [MSVTA120](#) [FSB50550AB](#)  
[NCV70501DW002G](#) [LC898301XA-MH](#) [LV8413GP-TE-L-E](#) [MSVGW45-14-3](#) [MSVGW45-14-4](#) [MSVGW45-14-5](#) [MSVGW54-14-4](#)  
[STK984-091A-E](#) [MP6519GQ-Z](#) [LB11651-E](#) [IRSM515-025DA4](#) [LV8127T-TLM-H](#) [MC33812EKR2](#) [NCP81382MNTXG](#) [TDA21801](#)  
[LB11851FA-BH](#) [NCV70627DQ001R2G](#)