

# MC100EPT622

## 3.3V LVTTTL/LVCMOS to LVPECL Translator

### Description

The MC100EPT622 is a 10-Bit LVTTTL/LVCMOS to LVPECL translator. Because LVPECL (Positive ECL) levels are used only +3.3 V and ground are required. The device has an OR-ed enable input which can accept either LVPECL (ENPECL) or TTL/LVCMOS inputs (ENTTL). If the inputs are left open, they will default to the enable state. The device design has been optimized for low channel-to-channel skew.

### Features

- 450 ps Typical Propagation Delay
- Maximum Frequency > 1.5 GHz Typical
- PECL Mode
- Operating Range:  $V_{CC} = 3.0\text{ V}$  to  $3.8\text{ V}$  with  $V_{EE} = 0\text{ V}$
- PNP LVTTTL Inputs for Minimal Loading
- Q Output Will Default HIGH with Inputs Open
- The 100 Series Contains Temperature Compensation
- Pb-Free Packages are Available\*



ON Semiconductor®

<http://onsemi.com>

### MARKING DIAGRAMS\*

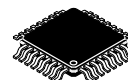

LQFP-32  
FA SUFFIX  
CASE 873A

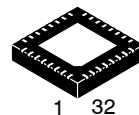
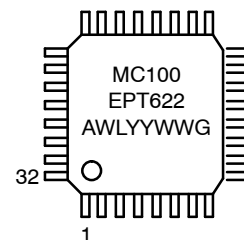

QFN32  
MN SUFFIX  
CASE 488AM

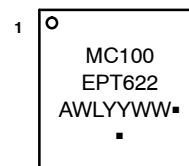

A = Assembly Location  
 WL = Wafer Lot  
 YY = Year  
 WW = Work Week  
 G or ■ = Pb-Free Package  
 (Note: Microdot may be in either location)

\*For additional marking information, refer to Application Note AND8002/D.

Table 1. TRUTH TABLE

ENPECL	ENTTL	D	Q
H	X	H	H
H	X	L	L
X	H	H	H
X	H	L	L
L	L	X	L

### ORDERING INFORMATION

See detailed ordering and shipping information in the package dimensions section on page 6 of this data sheet.

\*For additional information on our Pb-Free strategy and soldering details, please download the ON Semiconductor Soldering and Mounting Techniques Reference Manual, SOLDERRM/D.

# MC100EPT622

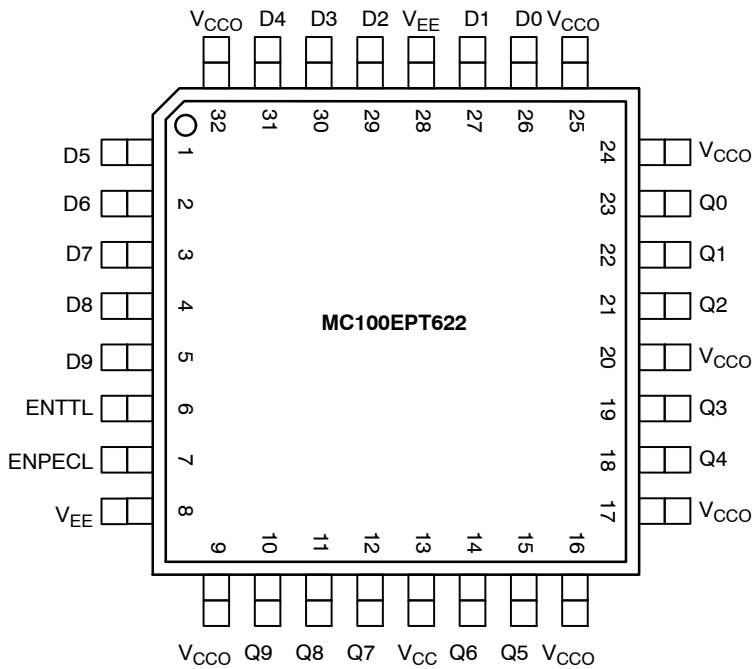

Warning: All  $V_{CC}$ ,  $V_{CCO}$ , and  $V_{EE}$  pins must be externally connected to Power Supply to guarantee proper operation.

**Figure 1. 32-Lead LQFP Pinout (Top View)**

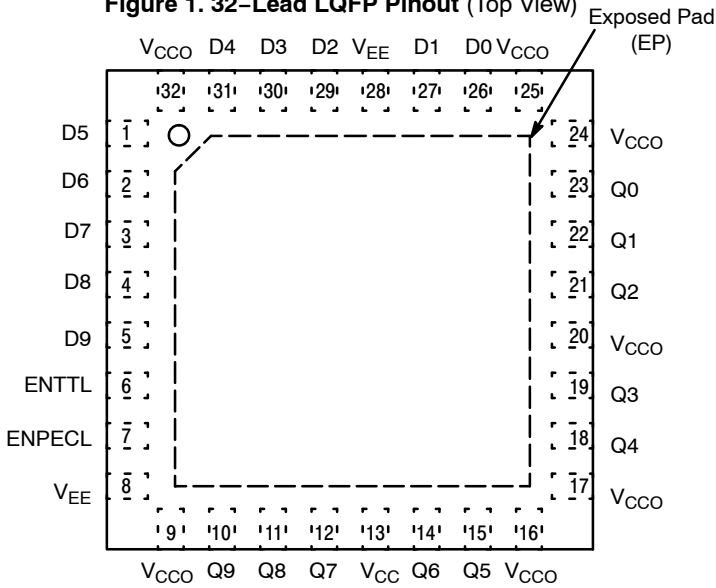

**Figure 3. 32-Lead QFN Pinout (Top View)**

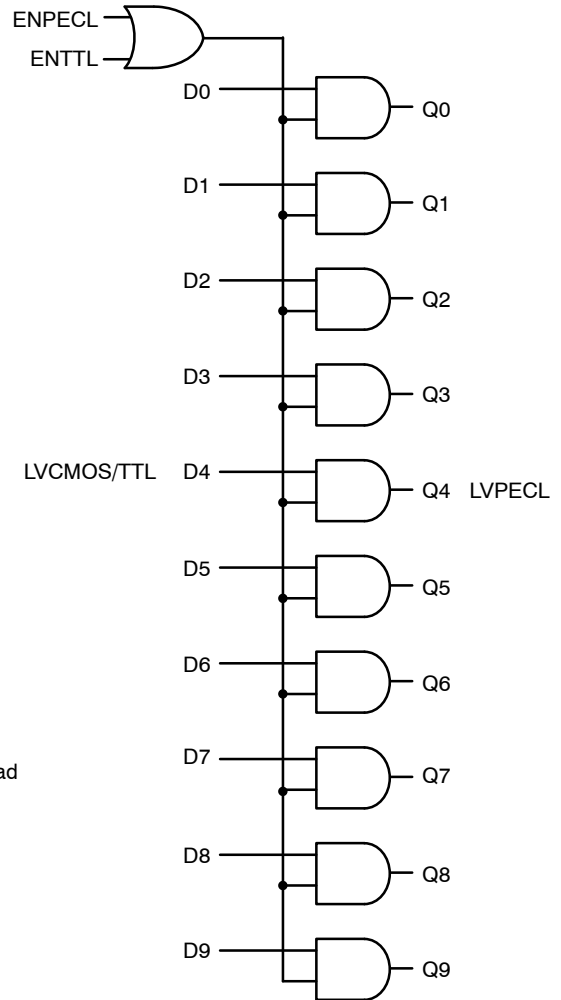

**Figure 2. Logic Symbol**

**Table 1. PIN DESCRIPTION**

Pin	Function
D0:9	Data Input (TTL)
Q0:9	Data Outputs (PECL)
ENTTL	Enable Control (TTL)
ENPECL	Enable Control (PECL)
$V_{CC}$ , $V_{CCO}$	Positive Supply
$V_{EE}$	Ground
EP	The exposed pad (EP) on the QFN-32 package bottom is thermally connected to the die for improved heat transfer out of the package. The exposed pad must be attached to a heat-sinking conduit. The pad is electrically connected to $V_{EE}$ .

# MC100EPT622

**Table 2. ATTRIBUTES**

Characteristics		Value	
Internal Input Pulldown Resistor		N/A	
Internal Input Pullup Resistor		N/A	
ESD Protection	Human Body Model Machine Model Charged Device Model	> 2 kV > 150 V > 2 kV	
Moisture Sensitivity, Indefinite Time Out of Drypack		Pb Pkg	Pb-Free Pkg
	LQFP-32 QFN-32	Level 2 N/A	Level 2 Level 1
Flammability Rating	Oxygen Index: 28 to 34	UL 94 V-0 @ 0.125 in	
Transistor Count		596 Devices	
Meets or exceeds JEDEC Spec EIA/JESD78 IC Latchup Test			

**Table 3. MAXIMUM RATINGS**

Symbol	Parameter	Condition 1	Condition 2	Rating	Unit
V <sub>CC</sub>	Power Supply	V <sub>EE</sub> = 0 V		5	V
V <sub>I</sub>	Input Voltage	V <sub>EE</sub> = 0 V	V <sub>I</sub> ≤ V <sub>CC</sub>	5 to 0	V
I <sub>out</sub>	Output Current	Continuous Surge		50 100	mA mA
T <sub>A</sub>	Operating Temperature Range			-40 to +85	°C
T <sub>stg</sub>	Storage Temperature Range			-65 to +150	°C
θ <sub>JA</sub>	Thermal Resistance (Junction-to-Ambient)	0 lfpm 500 lfpm	32 LQFP 32 LQFP	80 55	°C/W °C/W
θ <sub>JC</sub>	Thermal Resistance (Junction-to-Case)	Standard Board	32 LQFP	12 to 17	°C/W
θ <sub>JA</sub>	Thermal Resistance (Junction-to-Ambient)	0 lfpm 500 lfpm	QFN-32 QFN-32	31 27	°C/W °C/W
θ <sub>JC</sub>	Thermal Resistance (Junction-to-Case)	2S2P	QFN-32	12	°C/W
T <sub>sol</sub>	Wave Solder	Pb Pb-Free		265 265	°C

Stresses exceeding Maximum Ratings may damage the device. Maximum Ratings are stress ratings only. Functional operation above the Recommended Operating Conditions is not implied. Extended exposure to stresses above the Recommended Operating Conditions may affect device reliability.

**Table 4. TTL INPUT DC CHARACTERISTICS** V<sub>CC</sub> = 3.3 V, GND = 0.0 V, T<sub>A</sub> = -40°C to 85°C

Symbol	Characteristic	Condition	Min	Typ	Max	Unit
I <sub>IH</sub>	Input HIGH Current	V <sub>IN</sub> = 2.7 V			25	μA
I <sub>IHH</sub>	Input HIGH Current MAX	V <sub>IN</sub> = V <sub>CC</sub>			100	μA
I <sub>IL</sub>	Input LOW Current	V <sub>IN</sub> = 0.5 V			-0.6	mA
V <sub>IK</sub>	Input Clamp Voltage	I <sub>IN</sub> = -18 mA	-1.2	-0.9		V
V <sub>IH</sub>	Input HIGH Voltage		2.0			V
V <sub>IL</sub>	Input LOW Voltage				0.8	V

NOTE: Device will meet the specifications after thermal equilibrium has been established when mounted in a test socket or printed circuit board with maintained transverse airflow greater than 500 lfpm. Electrical parameters are guaranteed only over the declared operating temperature range. Functional operation of the device exceeding these conditions is not implied. Device specification limit values are applied individually under normal operating conditions and not valid simultaneously.

# MC100EPT622

**Table 5. PECL INPUT DC CHARACTERISTICS**  $V_{CC} = 3.3\text{ V}$ ,  $GND = 0.0\text{ V}$ ,  $T_A = -40^\circ\text{C}$  to  $85^\circ\text{C}$

Symbol	Characteristic	Condition	Min	Typ	Max	Unit
$I_{IH}$	Input HIGH Current	$V_{IN} = 2420\text{ mV}$			150	$\mu\text{A}$
$I_{IL}$	Input LOW Current	$V_{IN} = 1490\text{ mV}$			200	$\mu\text{A}$
$V_{IH}$	Input HIGH Voltage		2075		2420	mV
$V_{IL}$	Input LOW Voltage		1490		1675	mV

NOTE: Device will meet the specifications after thermal equilibrium has been established when mounted in a test socket or printed circuit board with maintained transverse airflow greater than 500 lfm. Electrical parameters are guaranteed only over the declared operating temperature range. Functional operation of the device exceeding these conditions is not implied. Device specification limit values are applied individually under normal operating conditions and not valid simultaneously.

**Table 6. PECL OUTPUT DC CHARACTERISTICS**  $V_{CC} = 3.3\text{ V}$ ,  $GND = 0.0\text{ V}$  (Note 1)

Symbol	Characteristic	$-40^\circ\text{C}$			$25^\circ\text{C}$			$85^\circ\text{C}$			Unit
		Min	Typ	Max	Min	Typ	Max	Min	Typ	Max	
$I_{EE}$	Power Supply Current	85	115	145	90	120	155	95	130	155	mA
$V_{OH}$	Output High Voltage (Note 2)	2155	2280	2405	2155	2280	2405	2155	2280	2405	mV
$V_{OL}$	Output Low Voltage (Note 2)	1355	1520	1700	1355	1520	1700	1355	1520	1700	mV

NOTE: Device will meet the specifications after thermal equilibrium has been established when mounted in a test socket or printed circuit board with maintained transverse airflow greater than 500 lfm. Electrical parameters are guaranteed only over the declared operating temperature range. Functional operation of the device exceeding these conditions is not implied. Device specification limit values are applied individually under normal operating conditions and not valid simultaneously.

1. Input and output parameters vary 1:1 with  $V_{CC}$ .
2. All loading with  $50\ \Omega$  to  $V_{CC}-2.0\text{ V}$ .

**Table 7. AC CHARACTERISTICS**  $V_{CC} = 3.0\text{ V}$  to  $3.8\text{ V}$  (Note 3)

Symbol	Characteristic	$-40^\circ\text{C}$			$25^\circ\text{C}$			$85^\circ\text{C}$			Unit
		Min	Typ	Max	Min	Typ	Max	Min	Typ	Max	
$f_{\max}$	Maximum Frequency (See Figure 4)	1.0	1.5		1.0	1.5		1.0	1.5		GHz
$t_{PLH}$ , $t_{PHL}$	Propagation Delay to Output (Figure 5, Note 4) D to Q ENPECL to Q ENTTL to Q	100 150 300	450 500 450	800 875 800	100 150 300	500 500 500	875 875 800	100 200 300	500 550 500	800 925 800	ps
$t_{JITTER}$	Random Clock Jitter (RMS) (See Figure 4)		0.7	3.0		0.7	3.0		0.7	3.0	ps
$t_r / t_f$	Output Rise/Fall Times (20% - 80%)	100	200	450	100	200	250	100	200	300	ps
$T_{SKEW}$	Duty Cycle Skew (Note 5) D to Q Channel 0-7 Channel 8-9 ENPECL to Q ENTTL to Q		120 200 120 100	375 775 400 275		120 200 120 100	375 775 400 275		120 200 120 100	375 775 400 275	ps

NOTE: Device will meet the specifications after thermal equilibrium has been established when mounted in a test socket or printed circuit board with maintained transverse airflow greater than 500 lfm. Electrical parameters are guaranteed only over the declared operating temperature range. Functional operation of the device exceeding these conditions is not implied. Device specification limit values are applied individually under normal operating conditions and not valid simultaneously.

3. Measured using a 2.4 V source, 50% duty cycle clock source. All loading with  $50\ \Omega$  to  $V_{CC}-2.0\text{ V}$ .
4. 1.5 V to 50% point of the output.
5. Duty cycle skew  $|t_{PLH} - t_{PHL}|$  on the specific path.

# MC100EPT622

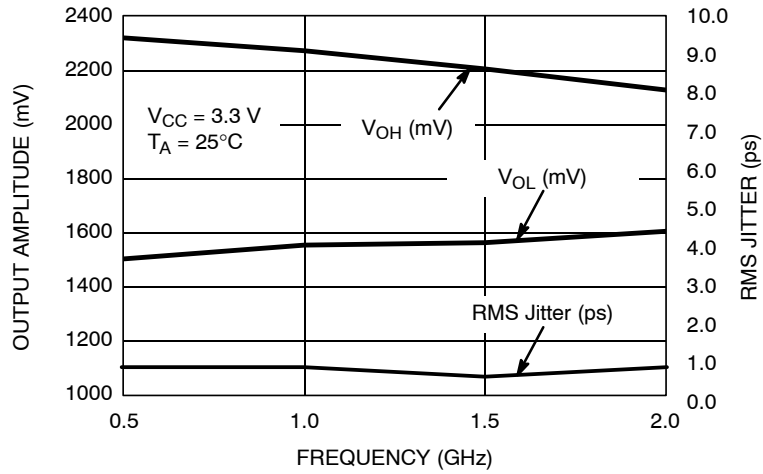

Figure 4. Average Output Amplitude/Jitter (3.3 V, 25°C)

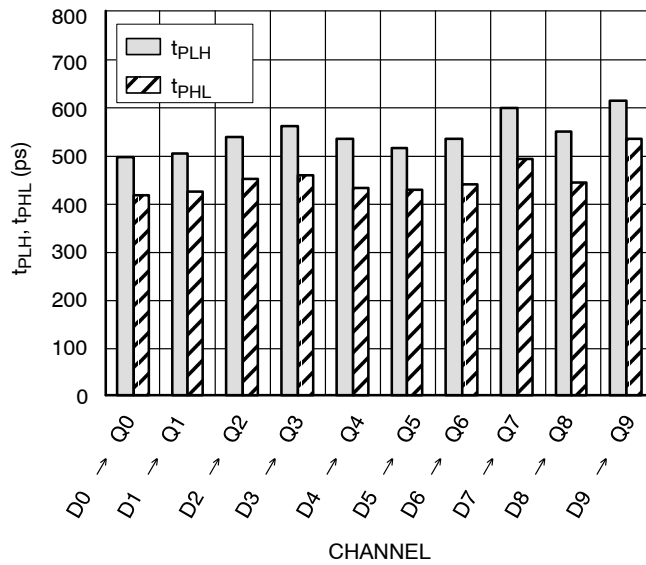

Figure 5. Average Propagation Delay (3.3 V, 25°C)

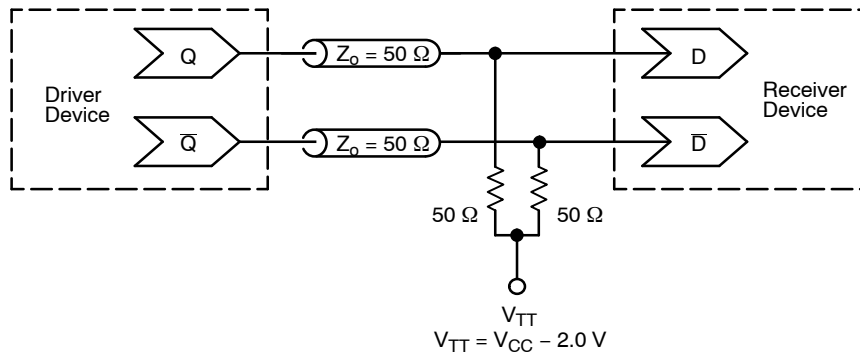

Figure 6. Typical Termination for Output Driver and Device Evaluation (See Application Note AND8020/D – Termination of ECL Logic Devices.)

# MC100EPT622

## ORDERING INFORMATION

Device	Package	Shipping†
MC100EPT622FA	LQFP-32	250 Units / Tray
MC100EPT622FAG	LQFP-32 (Pb-Free)	250 Units / Tray
MC100EPT622FAR2G	LQFP-32 (Pb-Free)	2000 / Tape & Reel
MC100EPT622MNG	QFN32 (Pb-Free)	74 Units / Rail
MC100EPT622MNR4G	QFN32 (Pb-Free)	1000 / Tape & Reel

†For information on tape and reel specifications, including part orientation and tape sizes, please refer to our Tape and Reel Packaging Specifications Brochure, BRD8011/D.

### Resource Reference of Application Notes

- AN1405/D** - ECL Clock Distribution Techniques
- AN1406/D** - Designing with PECL (ECL at +5.0 V)
- AN1503/D** - ECLinPS™ I/O SPiCE Modeling Kit
- AN1504/D** - Metastability and the ECLinPS Family
- AN1568/D** - Interfacing Between LVDS and ECL
- AN1672/D** - The ECL Translator Guide
- AND8001/D** - Odd Number Counters Design
- AND8002/D** - Marking and Date Codes
- AND8020/D** - Termination of ECL Logic Devices
- AND8066/D** - Interfacing with ECLinPS
- AND8090/D** - AC Characteristics of ECL Devices

# MC100EPT622

## PACKAGE DIMENSIONS

32 LEAD LQFP  
CASE 873A-02  
ISSUE C

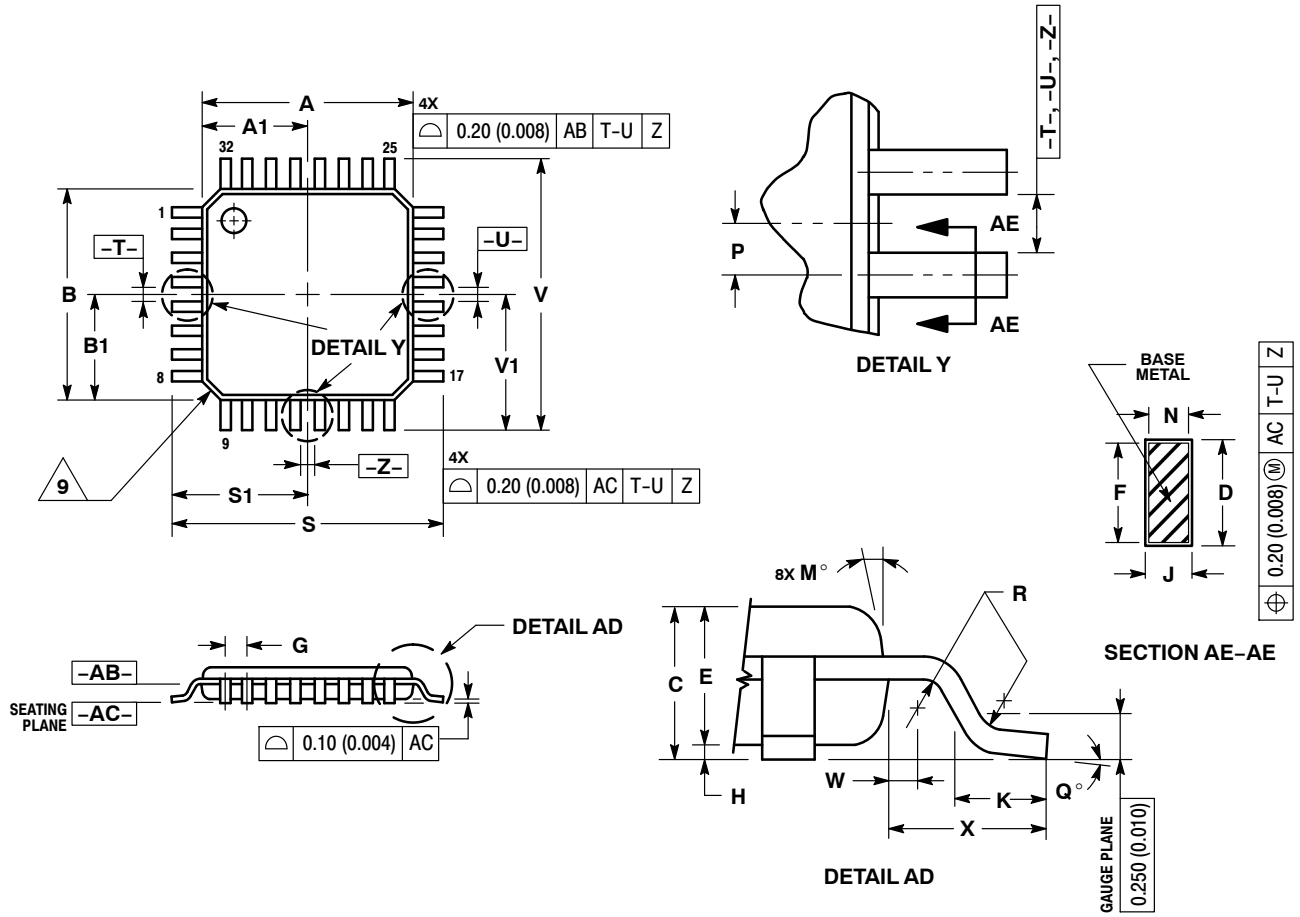

# MC100EPT622

## PACKAGE DIMENSIONS

QFN32 5x5, 0.5 P  
CASE 488AM-01  
ISSUE 0

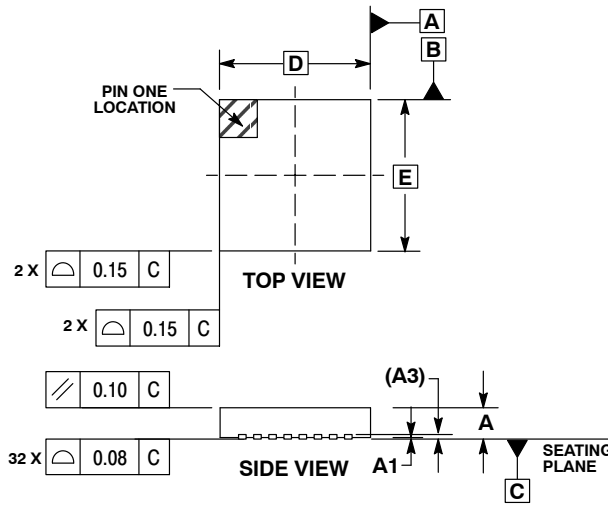

**NOTES:**

1. DIMENSIONS AND TOLERANCING PER ASME Y14.5M, 1994.
2. CONTROLLING DIMENSION: MILLIMETERS.
3. DIMENSION b APPLIES TO PLATED TERMINAL AND IS MEASURED BETWEEN 0.25 AND 0.30 MM TERMINAL
4. COPLANARITY APPLIES TO THE EXPOSED PAD AS WELL AS THE TERMINALS.

MILLIMETERS			
DIM	MIN	NOM	MAX
A	0.800	0.900	1.000
A1	0.000	0.025	0.050
A3	0.200 REF		
b	0.180	0.250	0.300
D	5.00 BSC		
D2	2.950	3.100	3.250
E	5.00 BSC		
E2	2.950	3.100	3.250
e	0.500 BSC		
K	0.200	---	---
L	0.300	0.400	0.500

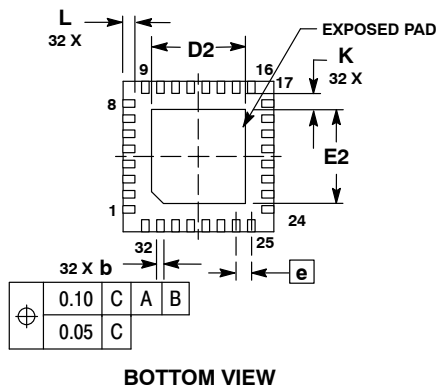

**SOLDERING FOOTPRINT\***

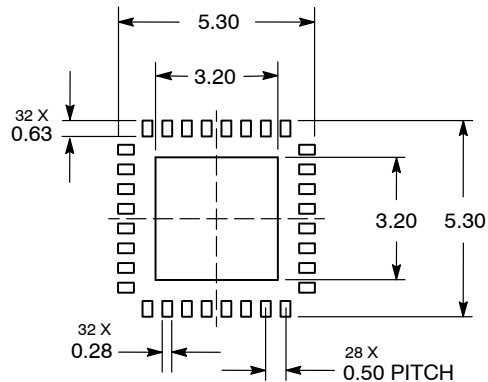

\*For additional information on our Pb-Free strategy and soldering details, please download the ON Semiconductor Soldering and Mounting Techniques Reference Manual, SOLDERRM/D.

ECLinPS is a trademark of Semiconductor Components Industries, LLC (SCILLC).

ON Semiconductor and are registered trademarks of Semiconductor Components Industries, LLC (SCILLC). SCILLC reserves the right to make changes without further notice to any products herein. SCILLC makes no warranty, representation or guarantee regarding the suitability of its products for any particular purpose, nor does SCILLC assume any liability arising out of the application or use of any product or circuit, and specifically disclaims any and all liability, including without limitation special, consequential or incidental damages. "Typical" parameters which may be provided in SCILLC data sheets and/or specifications can and do vary in different applications and actual performance may vary over time. All operating parameters, including "Typicals" must be validated for each customer application by customer's technical experts. SCILLC does not convey any license under its patent rights nor the rights of others. SCILLC products are not designed, intended, or authorized for use as components in systems intended for surgical implant into the body, or other applications intended to support or sustain life, or for any other application in which the failure of the SCILLC product could create a situation where personal injury or death may occur. Should Buyer purchase or use SCILLC products for any such unintended or unauthorized application, Buyer shall indemnify and hold SCILLC and its officers, employees, subsidiaries, affiliates, and distributors harmless against all claims, costs, damages, and expenses, and reasonable attorney fees arising out of, directly or indirectly, any claim of personal injury or death associated with such unintended or unauthorized use, even if such claim alleges that SCILLC was negligent regarding the design or manufacture of the part. SCILLC is an Equal Opportunity/Affirmative Action Employer. This literature is subject to all applicable copyright laws and is not for resale in any manner.

**PUBLICATION ORDERING INFORMATION**

**LITERATURE FULFILLMENT:**  
Literature Distribution Center for ON Semiconductor  
P.O. Box 5163, Denver, Colorado 80217 USA  
**Phone:** 303-675-2175 or 800-344-3860 Toll Free USA/Canada  
**Fax:** 303-675-2176 or 800-344-3867 Toll Free USA/Canada  
**Email:** orderlit@onsemi.com

**N. American Technical Support:** 800-282-9855 Toll Free USA/Canada  
**Europe, Middle East and Africa Technical Support:**  
Phone: 421 33 790 2910  
**Japan Customer Focus Center**  
Phone: 81-3-5773-3850

**ON Semiconductor Website:** [www.onsemi.com](http://www.onsemi.com)  
**Order Literature:** <http://www.onsemi.com/orderlit>  
For additional information, please contact your local Sales Representative



## X-ON Electronics

Largest Supplier of Electrical and Electronic Components

*Click to view similar products for [Translation - Voltage Levels](#) category:*

*Click to view products by [ON Semiconductor](#) manufacturer:*

Other Similar products are found below :

[NLSX4373DMR2G](#) [NLSX5012MUTAG](#) [HV583GA-G](#) [NLSX0102FCT1G](#) [NLSX0102FCT2G](#) [NLSX4302EBMUTCG](#) [NLVSX4373DR2G](#)  
[PCA9306FMUTAG](#) [SY10H351JZ](#) [MC100EPT622MNG](#) [MAX9374AEKA+T](#) [MAX3378EETD+](#) [MAX34405BEZT+](#) [NLSX3014MUTAG](#)  
[NVT4556BUKZ](#) [NLSV4T244EMUTAG](#) [NLSX5011MUTCG](#) [NLV9306USG](#) [NLVSX4014MUTAG](#) [MAX34405BEZT+T](#)  
[NLSV4T3144MUTAG](#) [NSV12200LT1G](#) [NLVSX4373MUTAG](#) [NB3U23CMNTAG](#) [MAX3371ELT+T](#) [MAX3008EUP+T](#)  
[NLVPCA9306AMUTCG](#) [NLSX3013BFCT1G](#) [MAX9378EUA+T](#) [NLV7WBD3125USG](#) [NLV14504BDTG](#) [NLSX3012DMR2G](#)  
[NLSX5012DR2G](#) [MAX3391EEUD+T](#) [MAX3379EETD+](#) [PI4ULS3V4857GEAEX](#) [MAX3391EEBC+T](#) [MAX14842ATE+T](#)  
[74AVCH1T45FZ4-7](#) [CLVC16T245MDGGREP](#) [HEF4104BT](#) [TC74LCX16245\(EL,F\)](#) [MC10H124FNG](#) [CAVCB164245MDGGREP](#)  
[7WBD383USG](#) [NVT2001GM,115](#) [CLVC8T245MRHLTEP](#) [74LVC1G175GS,132](#) [FXLA104UM12X](#) [FXMA2102UMX](#)