

ON Semiconductor

Is Now

onsemi™

To learn more about onsemi™, please visit our website at
www.onsemi.com

onsemi and **onsemi** and other names, marks, and brands are registered and/or common law trademarks of Semiconductor Components Industries, LLC dba "**onsemi**" or its affiliates and/or subsidiaries in the United States and/or other countries. **onsemi** owns the rights to a number of patents, trademarks, copyrights, trade secrets, and other intellectual property. A listing of **onsemi** product/patent coverage may be accessed at www.onsemi.com/site/pdf/Patent-Marking.pdf. **onsemi** reserves the right to make changes at any time to any products or information herein, without notice. The information herein is provided "as-is" and **onsemi** makes no warranty, representation or guarantee regarding the accuracy of the information, product features, availability, functionality, or suitability of its products for any particular purpose, nor does **onsemi** assume any liability arising out of the application or use of any product or circuit, and specifically disclaims any and all liability, including without limitation special, consequential or incidental damages. Buyer is responsible for its products and applications using **onsemi** products, including compliance with all laws, regulations and safety requirements or standards, regardless of any support or applications information provided by **onsemi**. "Typical" parameters which may be provided in **onsemi** data sheets and/or specifications can and do vary in different applications and actual performance may vary over time. All operating parameters, including "Typicals" must be validated for each customer application by customer's technical experts. **onsemi** does not convey any license under any of its intellectual property rights nor the rights of others. **onsemi** products are not designed, intended, or authorized for use as a critical component in life support systems or any FDA Class 3 medical devices or medical devices with a same or similar classification in a foreign jurisdiction or any devices intended for implantation in the human body. Should Buyer purchase or use **onsemi** products for any such unintended or unauthorized application, Buyer shall indemnify and hold **onsemi** and its officers, employees, subsidiaries, affiliates, and distributors harmless against all claims, costs, damages, and expenses, and reasonable attorney fees arising out of, directly or indirectly, any claim of personal injury or death associated with such unintended or unauthorized use, even if such claim alleges that **onsemi** was negligent regarding the design or manufacture of the part. **onsemi** is an Equal Opportunity/Affirmative Action Employer. This literature is subject to all applicable copyright laws and is not for resale in any manner. Other names and brands may be claimed as the property of others.

Low-Voltage CMOS Octal Buffer

With 5 V–Tolerant Inputs and Outputs
(3–State, Non–Inverting)

MC74LCX244A

The MC74LCX244A is a high performance, non–inverting octal buffer operating from a 1.65 to 3.6 V supply. High impedance TTL compatible inputs significantly reduce current loading to input drivers while TTL compatible outputs offer improved switching noise performance. A V_I specification of 5.5 V allows MC74LCX244A inputs to be safely driven from 5 V devices. The MC74LCX244A is suitable for memory address driving and all TTL level bus oriented transceiver applications.

Current drive capability is 24 mA at the outputs. The Output Enable (\overline{OE}) input, when HIGH, disables the output by placing them in a HIGH Z condition.

Features

- Designed for 1.65 to 3.6 V V_{CC} Operation
- 5 V Tolerant – Interface Capability With 5 V TTL Logic
- Supports Live Insertion and Withdrawal
- I_{OFF} Specification Guarantees High Impedance When $V_{CC} = 0$ V
- LVTTTL Compatible
- LVC MOS Compatible
- 24 mA Balanced Output Sink and Source Capability
- Near Zero Static Supply Current in All Three Logic States (10 μ A)
Substantially Reduces System Power Requirements
- Latchup Performance Exceeds 100 mA
- ESD Performance:
 - ◆ Human Body Model >2000 V
- NLV Prefix for Automotive and Other Applications Requiring Unique Site and Control Change Requirements; AEC–Q100 Qualified and PPAP Capable
- These Devices are Pb–Free, Halogen Free/BFR Free and are RoHS Compliant



ON Semiconductor®

www.onsemi.com



TSSOP-20
DT SUFFIX
CASE 948E

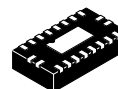

QFN20
MN SUFFIX
CASE 485CB

MARKING DIAGRAMS

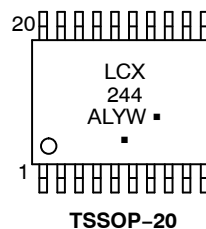

TSSOP-20

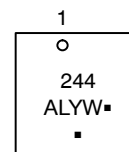

QFN20 – 485CB

A = Assembly Location
L, WL = Wafer Lot
Y, YY = Year
W, WW = Work Week
G or ■ = Pb–Free Package

(Note: Microdot may be in either location)

ORDERING INFORMATION

See detailed ordering and shipping information on page 6 of this data sheet.

MC74LCX244A

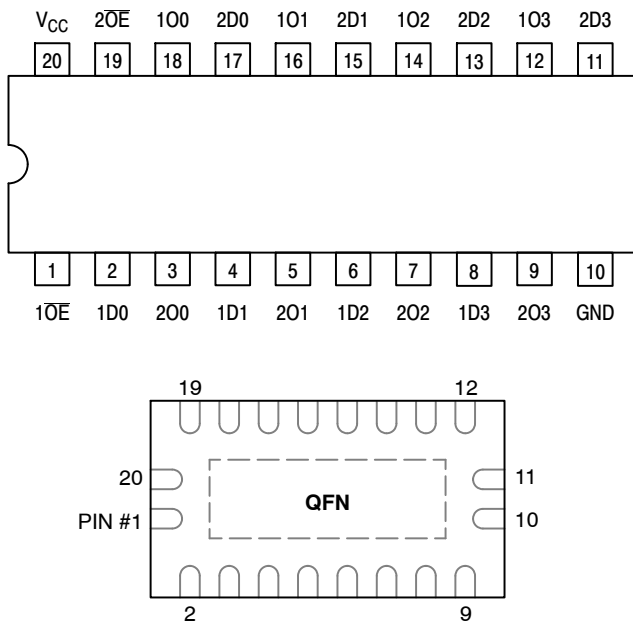

Figure 1. Pinouts: 20-Lead (Top View)

PIN NAMES

PINS	FUNCTION
$n\overline{OE}$	Output Enable Inputs
1Dn, 2Dn	Data Inputs
1On, 2On	3-State Outputs

TRUTH TABLE

INPUTS		OUTPUTS
$1\overline{OE}$ $2\overline{OE}$	1Dn 2Dn	1On, 2On
L	L	L
L	H	H
H	X	Z

H = High Voltage Level
 L = Low Voltage Level
 Z = High Impedance State
 X = High or Low Voltage Level and Transitions are Acceptable
 For I_{CC} reasons, DO NOT FLOAT Inputs

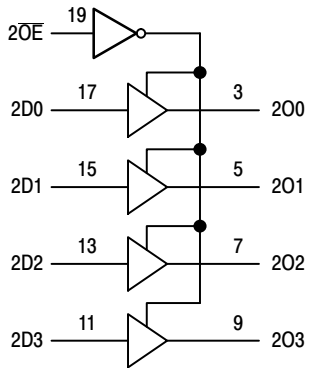
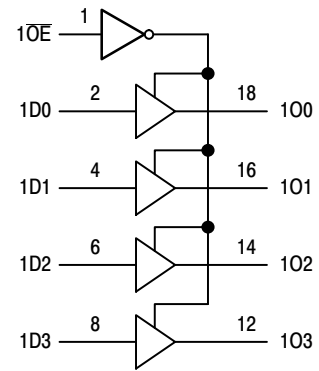

Figure 2. Logic Diagram

MC74LCX244A

MAXIMUM RATINGS

Symbol	Parameter	Value	Unit
V_I	DC Input Voltage (Note 1)	-0.5 to +6.5	V
V_O	DC Output Voltage (Note 1) Active-Mode (High or Low State)	-0.5 to $V_{CC} + 0.5$	V
	Tri-State Mode	-0.5 to +6.5	
	Power-Down Mode ($V_{CC} = 0$ V)	-0.5 to +6.5	
I_{IK}	DC Input Diode Current $V_{IN} < GND$	-50	mA
I_{OK}	DC Output Diode Current $V_{OUT} < GND$	-50	mA
I_O	DC Output Source/Sink Current	± 50	mA
I_{CC}	DC Supply Current Per Supply Pin	± 100	mA
I_{GND}	DC Supply Current Per Ground Pin	± 100	mA
T_{STG}	Storage Temperature Range	-65 to +150	$^{\circ}C$
MSL	Moisture Sensitivity	Level 1	
F_R	Flammability Rating Oxygen Index: 28 to 34	UL 94 V-0 @ 0.125 in	
V_{ESD}	ESD Withstand Voltage (Note 2) Human Body Model Charged Device Model	> 2000 N/A	V
$I_{LATCHUP}$	Latchup Performance (Note 3)	± 100	mA

Stresses exceeding those listed in the Maximum Ratings table may damage the device. If any of these limits are exceeded, device functionality should not be assumed, damage may occur and reliability may be affected.

- I_O absolute maximum rating must be observed.
- HBM tested to EIA / JESD22-A114-A. CDM tested to JESD22-C101-A. JEDEC recommends that ESD qualification to EIA/JESD22-A115A (Machine Model) be discontinued.
- Tested to EIA/JESD78 Class II.

RECOMMENDED OPERATING CONDITIONS

Symbol	Parameter	Min	Typ	Max	Unit
V_{CC}	Supply Voltage Operating	1.65	3.3	3.6	V
	Data Retention Only	1.5	3.3	3.6	
V_I	Digital Input Voltage	0	-	5.5	V
V_O	Output Voltage Active Mode (High or Low State)	0	-	V_{CC}	V
	Tri-State Mode	0	-	5.5	
	Power Down Mode ($V_{CC} = 0$ V)	0	-	5.5	
T_A	Operating Free-Air Temperature	-40	-	+125	$^{\circ}C$
t_r, t_f	Input Transition Rise or Fall Rate $V_I =$ from 0.8 V to 2.0 V, $V_{CC} = 3.0$ V	0	-	10	ns/V

Functional operation above the stresses listed in the Recommended Operating Ranges is not implied. Extended exposure to stresses beyond the Recommended Operating Ranges limits may affect device reliability.

MC74LCX244A

DC ELECTRICAL CHARACTERISTICS

Symbol	Parameter	Conditions	V _{CC} (V)	T _A = -40°C to +85°C		T _A = -40°C to +125°C		Unit
				Min	Max	Min	Max	
V _{IH}	High-Level Input Voltage		1.65 to 1.95	0.65 x V _{CC}	-	0.65 x V _{CC}	-	V
			2.3 to 2.7	1.7	-	1.7	-	
			2.7 to 3.6	2.0	-	2.0	-	
V _{IL}	Low-Level Input Voltage		1.65 to 1.95	-	0.35 x V _{CC}	-	0.35 x V _{CC}	V
			2.3 to 2.7	-	0.7	-	0.7	
			2.7 to 3.6	-	0.8	-	0.8	
V _{OH}	High-Level Output Voltage	V _I = V _{IH} or V _{IL}						V
		I _{OH} = -100 μA	1.65 to 3.6	V _{CC} - 0.2	-	V _{CC} - 0.2	-	
		I _{OH} = -4 mA	1.65	1.2	-	1.2	-	
		I _{OH} = -8 mA	2.3	1.8	-	1.8	-	
		I _{OH} = -12 mA	2.7	2.2	-	2.2	-	
		I _{OH} = -16 mA	3.0	2.4	-	2.4	-	
		I _{OH} = -24 mA	3.0	2.2	-	2.2	-	
V _{OL}	Low-Level Output Voltage	V _I = V _{IH} or V _{IL}						V
		I _{OL} = 100 μA	1.65 to 3.6	-	0.2	-	0.2	
		I _{OL} = 4 mA	1.65	-	0.45	-	0.45	
		I _{OL} = 8 mA	2.3	-	0.6	-	0.6	
		I _{OL} = 12 mA	2.7	-	0.4	-	0.4	
		I _{OL} = 16 mA	3.0	-	0.4	-	0.4	
		I _{OL} = 24 mA	3.0	-	0.55	-	0.6	
I _I	Input Leakage Current	V _I = 0 to 5.5 V	3.6	-	±5.0	-	±5.0	μA
I _{OZ}	3-State Output Leakage Current	V _I = V _{IH} or V _{IL} , V _O = 0 V to 5.5 V	3.6	-	±5.0	-	±5.0	μA
I _{OFF}	Power Off Leakage Current	V _I = 5.5 V or V _O = 5.5 V	0	-	10	-	20	μA
I _{CC}	Quiescent Supply Current	V _I = 5.5 V or GND	3.6	-	10	-	10	μA
ΔI _{CC}	Increase in I _{CC} per Input	V _{IH} = V _{CC} - 0.6 V	2.3 to 3.6	-	500	-	500	μA

Product parametric performance is indicated in the Electrical Characteristics for the listed test conditions, unless otherwise noted. Product performance may not be indicated by the Electrical Characteristics if operated under different conditions.

MC74LCX244A

AC ELECTRICAL CHARACTERISTICS

Symbol	Parameter	Conditions	V _{CC} (V)	T _A = -40°C to +85°C		T _A = -40°C to +125°C		Unit
				Min	Max	Min	Max	
t _{PLH} , t _{PHL}	Propagation Delay, D to O	See Figures 3 and 4	1.65 to 1.95	-	10.3	-	10.3	ns
			2.3 to 2.7	-	7.8	-	7.8	
			2.7	-	7.5	-	7.5	
			3.0 to 3.6	-	6.5	-	6.5	
t _{PZH} , t _{PZL}	Output Enable Time, OE to O	See Figures 3 and 4	1.65 to 1.95	-	13.0	-	13.0	ns
			2.3 to 2.7	-	10.0	-	10.0	
			2.7	-	9.0	-	9.0	
			3.0 to 3.6	-	8.0	-	8.0	
t _{PHZ} , t _{PLZ}	Output Disable Time, OE to O	See Figures 3 and 4	1.65 to 1.95	-	11.0	-	11.0	ns
			2.3 to 2.7	-	8.4	-	8.4	
			2.7	-	8.0	-	8.0	
			3.0 to 3.6	-	7.0	-	7.0	
t _{OSHL} , t _{OSLH}	Output to Output Skew		1.65 to 1.95	-	-	-	-	ns
			2.3 to 2.7	-	-	-	-	
			2.7	-	-	-	-	
			3.0 to 3.6	-	1.0	-	1.0	

DYNAMIC SWITCHING CHARACTERISTICS

Symbol	Parameter	Test Condition	V _{CC} (V)	T _A = +25°C			Unit
				Min	Typ	Max	
V _{OLP}	Dynamic LOW Peak Voltage (Note 4)	C _L = 50 pF, V _{IH} = 3.3 V, V _{IL} = 0 V	3.3	-	0.8	-	V
		C _L = 30 pF, V _{IH} = 2.5 V, V _{IL} = 0 V	2.5	-	0.6	-	
V _{OLV}	Dynamic LOW Valley Voltage (Note 4)	C _L = 50 pF, V _{IH} = 3.3 V, V _{IL} = 0 V	3.3	-	-0.8	-	V
		C _L = 30 pF, V _{IH} = 2.5 V, V _{IL} = 0 V	2.5	-	-0.6	-	

4. Number of outputs defined as "n". Measured with "n-1" outputs switching from HIGH-to-LOW or LOW-to-HIGH. The remaining output is measured in the LOW state.

CAPACITIVE CHARACTERISTICS

Symbol	Parameter	Test Condition	Typical (T _A = 25°C)	Unit
C _{IN}	Input Capacitance	V _{CC} = 3.3 V, V _I = 0 V or V _{CC}	7	pF
C _{OUT}	Output Capacitance	V _{CC} = 3.3 V, V _I = 0 V or V _{CC}	8	pF
C _{PD}	Power Dissipation Capacitance (Note 5)	10 MHz, V _{CC} = 3.3 V, V _I = 0 V or V _{CC}	25	pF

5. C_{PD} is defined as the value of the internal equivalent capacitance which is calculated from the dynamic operating current consumption without load. Average operating current can be obtained by the equation I_{CC(OPR)} = C_{PD} • V_{CC} • f_{in} + I_{CC}. C_{PD} is used to determine the no-load dynamic power consumption: P_D = C_{PD} • V_{CC}² • f_{in} + I_{CC} • V_{CC}.

MC74LCX244A

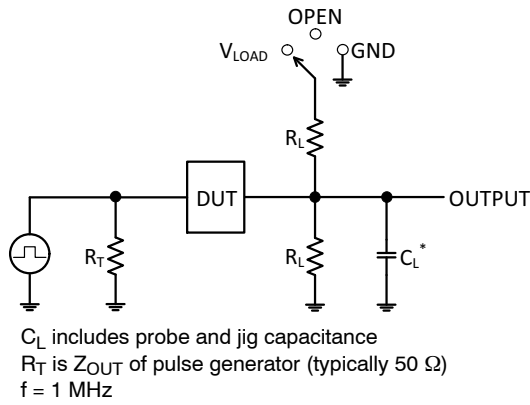

Test	Switch Position
t_{PLH} / t_{PHL}	Open
t_{PLZ} / t_{PZL}	V_{LOAD}
t_{PHZ} / t_{PZH}	GND

Figure 3. Test Circuits

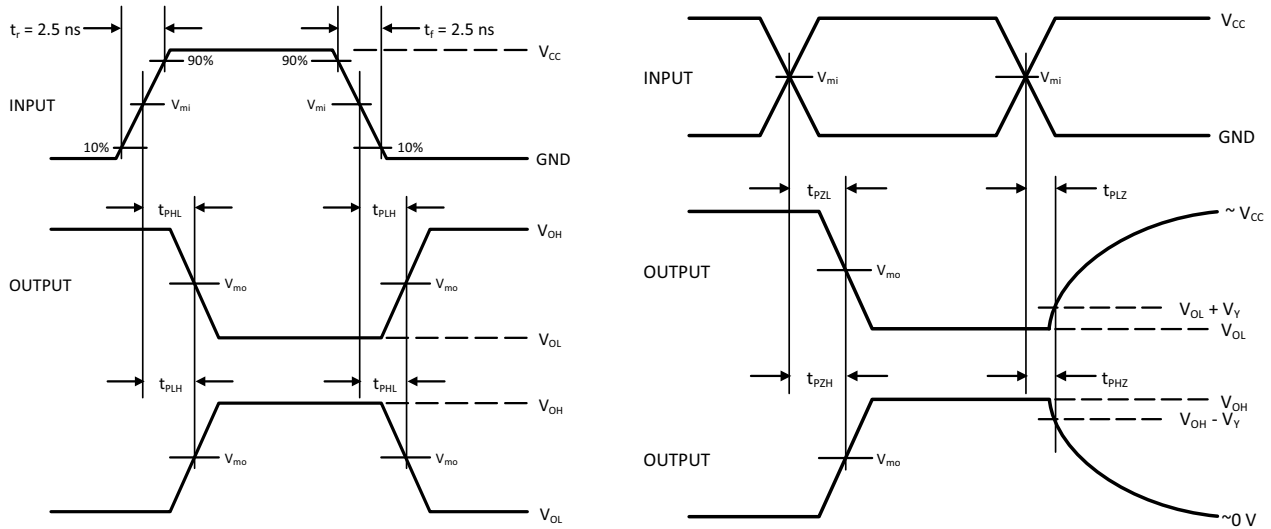

V_{CC} , V	R_L , Ω	C_L , pF	V_{LOAD}	V_{mi} , V	V_{mo} , V	V_Y , V
1.65 to 1.95	500	30	$2 \times V_{CC}$	$V_{CC}/2$	$V_{CC}/2$	0.15
2.3 to 2.7	500	30	$2 \times V_{CC}$	$V_{CC}/2$	$V_{CC}/2$	0.15
2.7	500	50	6 V	1.5	1.5	0.3
3.0 to 3.6	500	50	6 V	1.5	1.5	0.3

Figure 4. Switching Waveforms

ORDERING INFORMATION

Device	Package	Shipping [†]
MC74LCX244ADTR2G	TSSOP-20 (Pb-Free)	2500 / Tape & Reel
MC74LCX244AMN2TWG (Contact ON Semiconductor)	QFN20, 2.5x3.5 (Pb-Free)	3000 / Tape & Reel

[†]For information on tape and reel specifications, including part orientation and tape sizes, please refer to our Tape and Reel Packaging Specifications Brochure, BRD8011/D.

*NLV Prefix for Automotive and Other Applications Requiring Unique Site and Control Change Requirements; AEC-Q100 Qualified and PPAP Capable

MC74LCX244A

PACKAGE DIMENSIONS

TSSOP-20
CASE 948E
ISSUE D

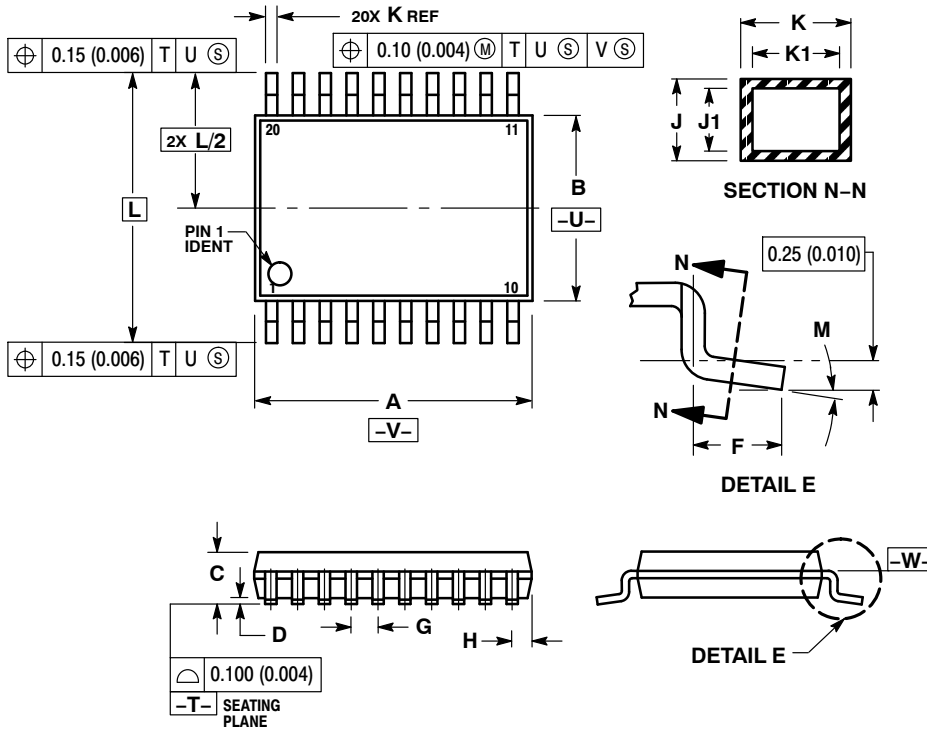

NOTES:

1. DIMENSIONING AND TOLERANCING PER ANSI Y14.5M, 1982.
2. CONTROLLING DIMENSION: MILLIMETER.
3. DIMENSION A DOES NOT INCLUDE MOLD FLASH, PROTRUSIONS OR GATE BURRS. MOLD FLASH OR GATE BURRS SHALL NOT EXCEED 0.15 (0.006) PER SIDE.
4. DIMENSION B DOES NOT INCLUDE INTERLEAD FLASH OR PROTRUSION. INTERLEAD FLASH OR PROTRUSION SHALL NOT EXCEED 0.25 (0.010) PER SIDE.
5. DIMENSION K DOES NOT INCLUDE DAMBAR PROTRUSION. ALLOWABLE DAMBAR PROTRUSION SHALL BE 0.08 (0.003) TOTAL IN EXCESS OF THE K DIMENSION AT MAXIMUM MATERIAL CONDITION.
6. TERMINAL NUMBERS ARE SHOWN FOR REFERENCE ONLY.
7. DIMENSION A AND B ARE TO BE DETERMINED AT DATUM PLANE -W-.

DIM	MILLIMETERS		INCHES	
	MIN	MAX	MIN	MAX
A	6.40	6.60	0.252	0.260
B	4.30	4.50	0.169	0.177
C	---	1.20	---	0.047
D	0.05	0.15	0.002	0.006
F	0.50	0.75	0.020	0.030
G	0.65 BSC		0.026 BSC	
H	0.27	0.37	0.011	0.015
J	0.09	0.20	0.004	0.008
J1	0.09	0.16	0.004	0.006
K	0.19	0.30	0.007	0.012
K1	0.19	0.25	0.007	0.010
L	6.40 BSC		0.252 BSC	
M	0°	8°	0°	8°

SOLDERING FOOTPRINT*

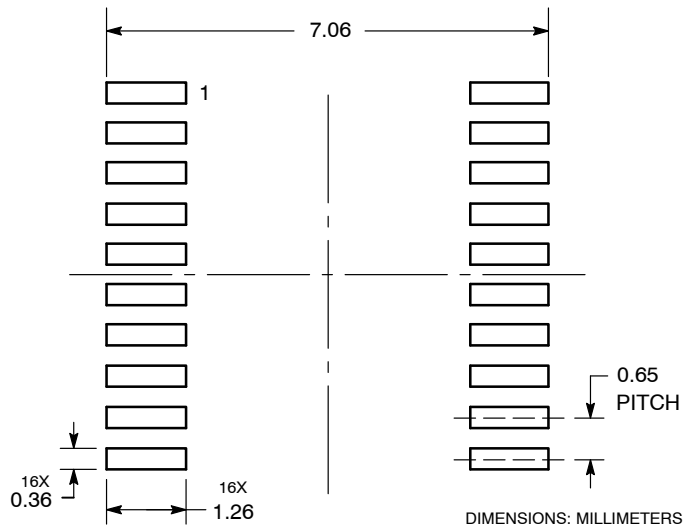

*For additional information on our Pb-Free strategy and soldering details, please download the ON Semiconductor Soldering and Mounting Techniques Reference Manual, SOLDERRM/D.

MC74LCX244A

PACKAGE DIMENSIONS

QFN20, 2.5x3.5, 0.4P
CASE 485CB
ISSUE O

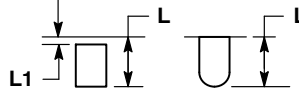
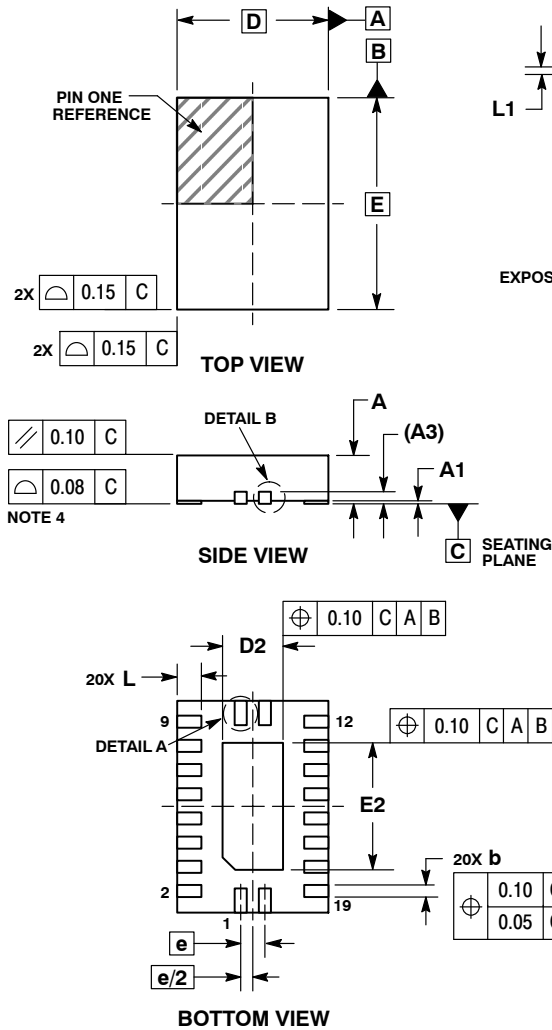

DETAIL A
ALTERNATE TERMINAL CONSTRUCTIONS

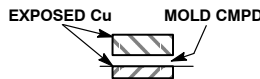

DETAIL B
ALTERNATE CONSTRUCTIONS

NOTES:

1. DIMENSIONING AND TOLERANCING PER ASME Y14.5M, 1994.
2. CONTROLLING DIMENSION: MILLIMETERS.
3. DIMENSIONS b APPLIES TO PLATED TERMINAL AND IS MEASURED BETWEEN 0.15 AND 0.30 MM FROM TERMINAL TIP.
4. COPLANARITY APPLIES TO THE EXPOSED PAD AS WELL AS THE TERMINALS.

DIM	MILLIMETERS	
	MIN	MAX
A	0.80	1.00
A1	0.00	0.05
A3	0.20 REF	
b	0.15	0.25
D	2.50 BSC	
D2	0.90	1.10
E	3.50 BSC	
E2	2.00	2.20
e	0.40 BSC	
L	0.35	0.45
L1	---	0.15

SOLDERING FOOTPRINT*

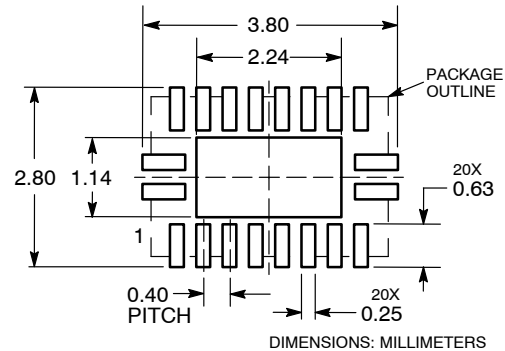

*For additional information on our Pb-Free strategy and soldering details, please download the ON Semiconductor Soldering and Mounting Techniques Reference Manual, SOLDERRM/D.

ON Semiconductor and are trademarks of Semiconductor Components Industries, LLC dba ON Semiconductor or its subsidiaries in the United States and/or other countries. ON Semiconductor owns the rights to a number of patents, trademarks, copyrights, trade secrets, and other intellectual property. A listing of ON Semiconductor's product/patent coverage may be accessed at www.onsemi.com/site/pdf/Patent-Marking.pdf. ON Semiconductor reserves the right to make changes without further notice to any products herein. ON Semiconductor makes no warranty, representation or guarantee regarding the suitability of its products for any particular purpose, nor does ON Semiconductor assume any liability arising out of the application or use of any product or circuit, and specifically disclaims any and all liability, including without limitation special, consequential or incidental damages. Buyer is responsible for its products and applications using ON Semiconductor products, including compliance with all laws, regulations and safety requirements or standards, regardless of any support or applications information provided by ON Semiconductor. "Typical" parameters which may be provided in ON Semiconductor data sheets and/or specifications can and do vary in different applications and actual performance may vary over time. All operating parameters, including "Typicals" must be validated for each customer application by customer's technical experts. ON Semiconductor does not convey any license under its patent rights nor the rights of others. ON Semiconductor products are not designed, intended, or authorized for use as a critical component in life support systems or any FDA Class 3 medical devices or medical devices with a same or similar classification in a foreign jurisdiction or any devices intended for implantation in the human body. Should Buyer purchase or use ON Semiconductor products for any such unintended or unauthorized application, Buyer shall indemnify and hold ON Semiconductor and its officers, employees, subsidiaries, affiliates, and distributors harmless against all claims, costs, damages, and expenses, and reasonable attorney fees arising out of, directly or indirectly, any claim of personal injury or death associated with such unintended or unauthorized use, even if such claim alleges that ON Semiconductor was negligent regarding the design or manufacture of the part. ON Semiconductor is an Equal Opportunity/Affirmative Action Employer. This literature is subject to all applicable copyright laws and is not for resale in any manner.

PUBLICATION ORDERING INFORMATION

LITERATURE FULFILLMENT:
Email Requests to: orderlit@onsemi.com

TECHNICAL SUPPORT
North American Technical Support:
Voice Mail: 1 800-282-9855 Toll Free USA/Canada
Phone: 011 421 33 790 2910

Europe, Middle East and Africa Technical Support:
Phone: 00421 33 790 2910
For additional information, please contact your local Sales Representative

X-ON Electronics

Largest Supplier of Electrical and Electronic Components

Click to view similar products for [Buffers & Line Drivers](#) category:

Click to view products by [ON Semiconductor](#) manufacturer:

Other Similar products are found below :

[LXV200-024SW](#) [74AUP2G34FW3-7](#) [HEF4043BP](#) [NL17SG125DFT2G](#) [NLU1GT126CMUTCG](#) [CD4041UBE](#) [54FCT240CTDB](#)
[74HCT540N](#) [DS14C88N](#) [070519XB](#) [NL17SZ07P5T5G](#) [74LVC2G17FW4-7](#) [CD4502BE](#) [5962-8982101PA](#) [61446R00](#) [74LVCE1G126FZ4-7](#)
[NL17SH17P5T5G](#) [74HCT126T14-13](#) [74LVC2G34FW4-7](#) [74VHC9126FT\(BJ\)](#) [RHRXH162244K1](#) [74AUP1G34FW5-7](#) [74LVC1G126FW4-7](#)
[74LVC2G126RA3-7](#) [74LVCE1G125FZ4-7](#) [74AUP1G126FW5-7](#) [54FCT240TLB](#) [74LVCE1G07FZ4-7](#) [NLX3G16DMUTCG](#)
[NLX2G06AMUTCG](#) [LE87100NQCT](#) [LE87285NQC](#) [LE87290YQC](#) [LE87290YQCT](#) [74AUP1G125FW5-7](#) [NLU2G16CMUTCG](#)
[MC74LCX244MN2TWG](#) [NL17SG17P5T5G](#) [NLV74HC125ADR2G](#) [NLVHCT245ADTR2G](#) [NLVVHC1G126DFT2G](#) [EL5623IRZ](#)
[ISL1539IRZ-T13](#) [MC100EP17MNG](#) [MC74HCT365ADR2G](#) [MC74LCX244ADTR2G](#) [NL27WZ126US](#) [NL37WZ16US](#) [NLU1G07MUTCG](#)
[NLU2G07MUTCG](#)