

MT9M114_55CSP_Demo3_Headboard

Page	Description
1	Title Page
2	Block Diagram
3	Pinout
4	MT9M114_K24B_SOC
5	Power Supply
6	External Interface
7	Clock & Reset_Multi Camera Intreface
8	Multi-Camera Block Drg

Rev	Who	Date	Description
Rev 0.0	jwrede	10/06/2014	Base Schematic for Custom Design
Rev 0.1	aralex	09/22/2015	- Design is based from MT9M114 CSP package Demo2 Rev1 board - Added Feedback clock to Demo3 circuitry
		09/30/2015	-Removed TP3 and TP4 : I2C test points -Removed C50, C51, C59, C60 decaps for 5V and 1.2V, Added TP7
		10/01/2015	-Removed I2C Debug Circuitry, C65 - Implemented the Master slave configuration as per that used in AR1335 HB
		10/07/2015	-Updated with review comments -Removed short in EEPROM section, corrected VDD and VDDIO nets near sensor, R2 deleted, changed voltage of RESET ckt from 3.3V to VDDIO_LS -Updated U3 from 24LC64-I/SN to 24FC64-I/SN
		10/07/2015	-Changed net names from OE_N to OE_L; SEN_RST_N to SEN_RST_L -Swapped the power headers for layout: JP4, JP5, JP6, JP7, JP8 -Updated block diagram
		10/07/2015	-changed R3 from 0603 to 0402 -changed C1, C30 from 0603 to 0402 [For BOM consolidation]
		10/08/2015	-changed C37 manf Murata to Panasonic (0402) [For BOM consolidation]
		10/08/2015	- Changed the Master slave circuit connections to cater to multi slave configuration, instead of one master and one slave
		10/09/2015	-Changed revision to 0.1, to keep BOM at same revision Changed note for P2 as per review comment by Shawyee (sync note)
		10/12/2015	Swapped pin connections on JP4, JP7, JP8 as per Joe's feedback to maintain uniformity between jumper power nets
10/13/2015	Updated the Multicamera Configuration, I2C Daisy Chain and Clock chain Block Diagrams		



ON Semiconductor®

Title Page		
Size C	Document Name MT9M114_55CSP_Demo3_Headboard	Rev 0.1
Date: Tuesday, October 13, 2015	Sheet 1	of 8

Block Diagram

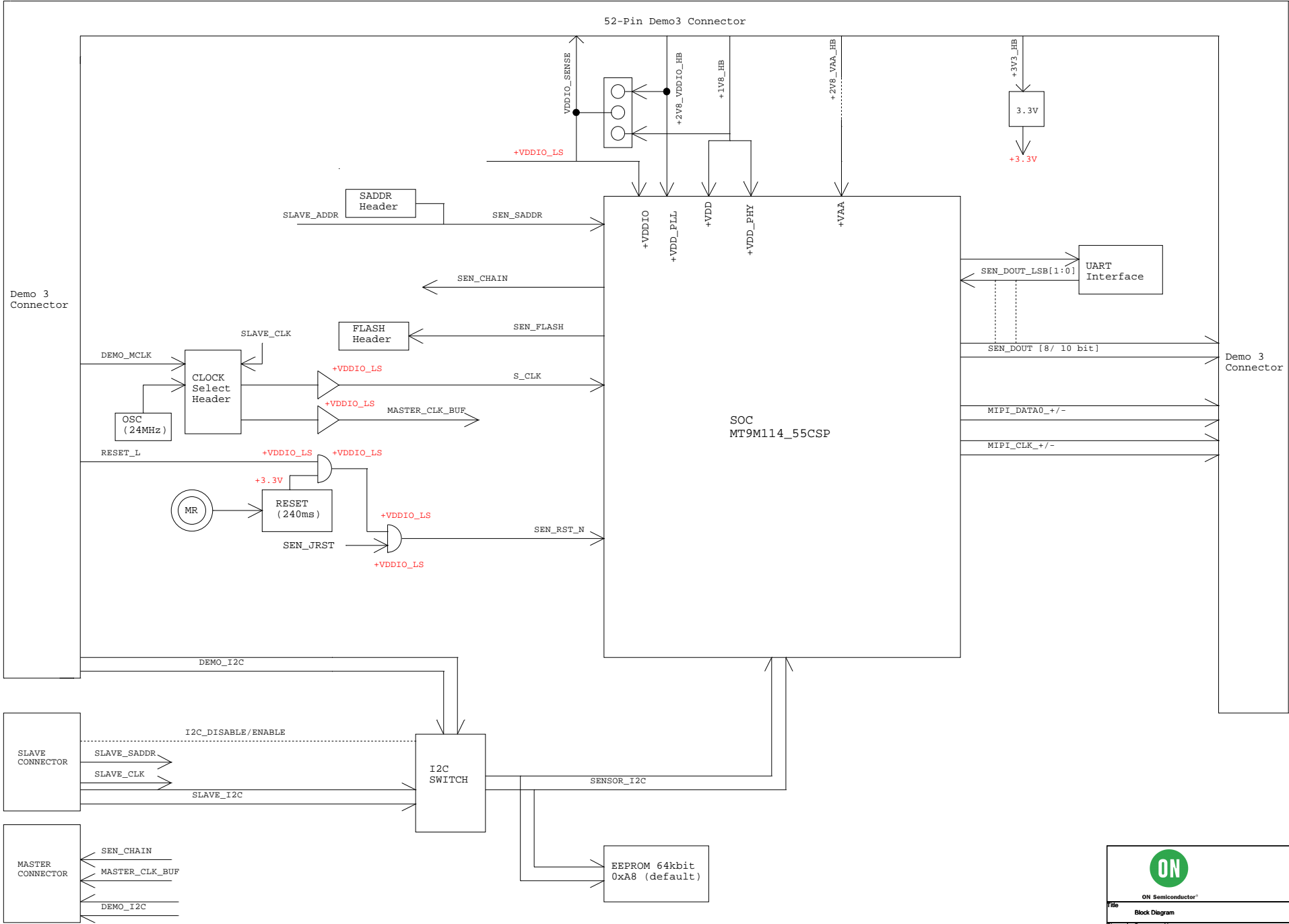

Script NOT executed

SENSOR MT9M114_55CSP PINOUT

	1	2	3	4	5	6	7	8
A	VAA	Reserved ¹	DOUT[6]	Dout[4]	Dout[2]	VDD	Dout[1]	VDD
B	GND	VAA	VDD_IO	Dout[5]	Dout[3]	GND	Dout[0]	VDD_IO
C	VDD	OE_BAR	AGND	GND	VDD_IO	FV	LV	
D	CONFIG	SCLK	SDATA	DOUT[7]	Reserved ¹	DOUT_LSB1	GND	VDD
E	VDD_IO	CHAIN	Reserved ¹	SADDR	RESET_BAR	DOUT_LSB0	GND	VDD_PHY
F	EXTCLK	PIXCLK	GND	TRST_BAR	DATA_N	DATA_P	CLK_P	CLK_N
G	VDD	FLASH	VDD	PGND ²	PGND ²	VDD_PLL	GND_PLL	GND_PLL



ON Semiconductor®

File		Pinout	
Size	Document Name	Rev	
C	MT9M114_55CSP_Demo3_Headboard	0.1	
Date:	Friday, October 09, 2015	Sheet	3 of 8

MT9M114_55CSP SOC

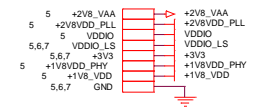

P1
 Jumper (1-2) : Parallel Interface (Default)
 Jumper (2-3) : Non-Parallel

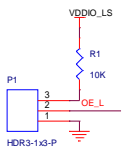

P2 (CONFIG)
 Jumper (1-2) :
 Jumper (2-3) : (Default)

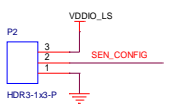

P5 (TRST)
 Jumper (1-2) : Normal mode (Default)
 Jumper (2-3) : Test Mode

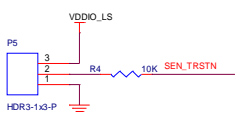

P6 (SADDR):
 Jumper (1-2) GND --> 0x90 (Default)
 Jumper (2-3) VDDIO_LS --> 0xBA
 Open --> Multi Camera Slave Mode

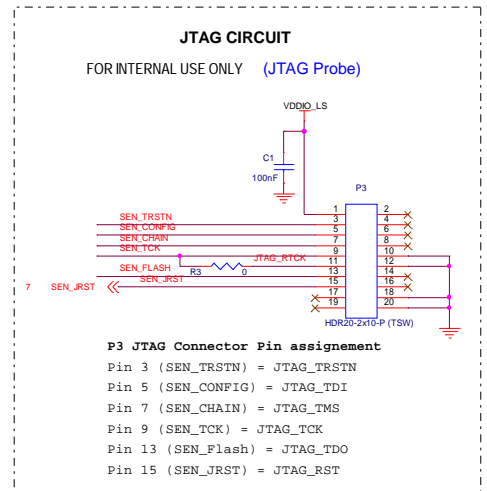
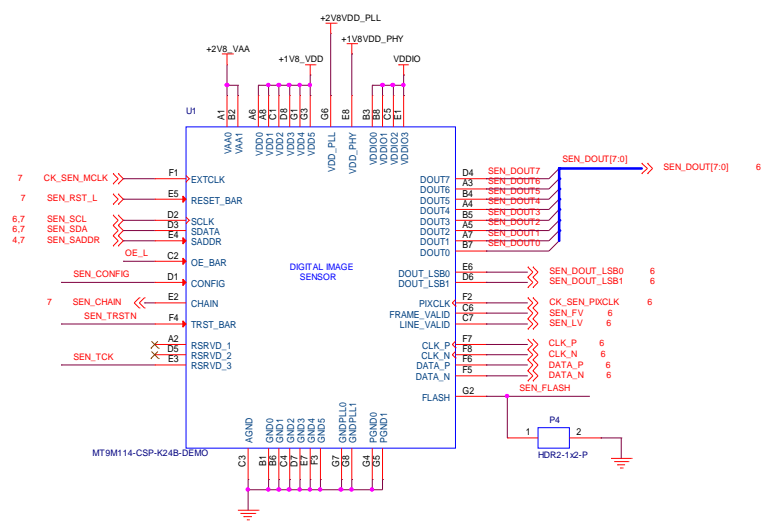
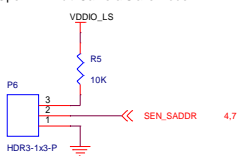

(Note for layout: - Place these testpads near the Demo3 I/F connector at the top side of PCB)

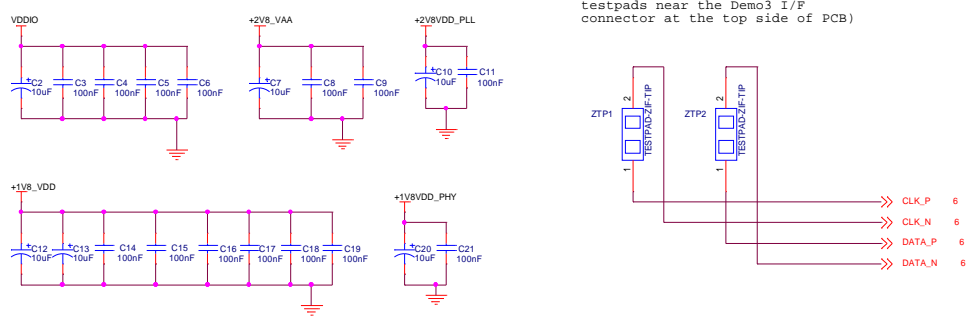

LENS MOUNT SOCKET

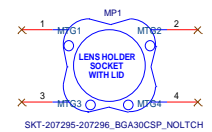

TRIPOD MOUNT

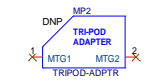

ON Semiconductor®
MT9M114 (K24B) SOC

File	MT9M114 (K24B) SOC	
Doc ID	Document Name	Rev
C	MT9M114_55CSP_Demo3_Headboard	0.1
Date:	Wednesday, November 04, 2015	Sheet 4 of 8

Power Supply

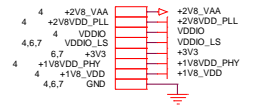

2.8V VAA Power supply

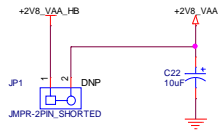

Peripheral 5V Power Supply

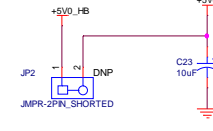

Layout: Mount LED on bottom side of PCB

VDD_PLL Power Supply

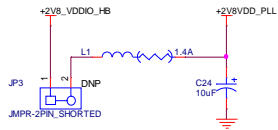

Peripheral 3.3V Supply

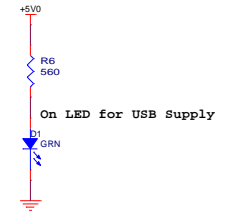
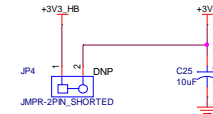

On LED for USB Supply

VDD-PHY Power Supply

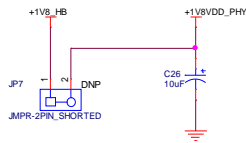

VDDIO & VDDIO_LS 1.8V/ 2.8V Supply

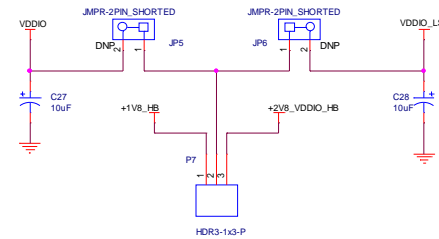

P7 Default Setting: 1-2 Short (1V8 operation)

VDD Power Supply

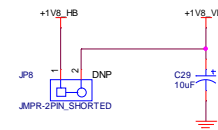

Fiducials

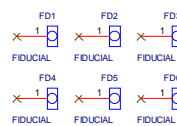

Mounting Holes

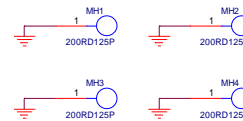

Ground Testpoints



ON Semiconductor®

Power Supply		
File	MT9M114_55CSP_Demo3_Headboard	
Size	Document Name	Rev
C	MT9M114_55CSP_Demo3_Headboard	0.1
Date:	Monday, October 12, 2015	Sheet 5 of 8

External Interface



DEMO3 INTERFACE

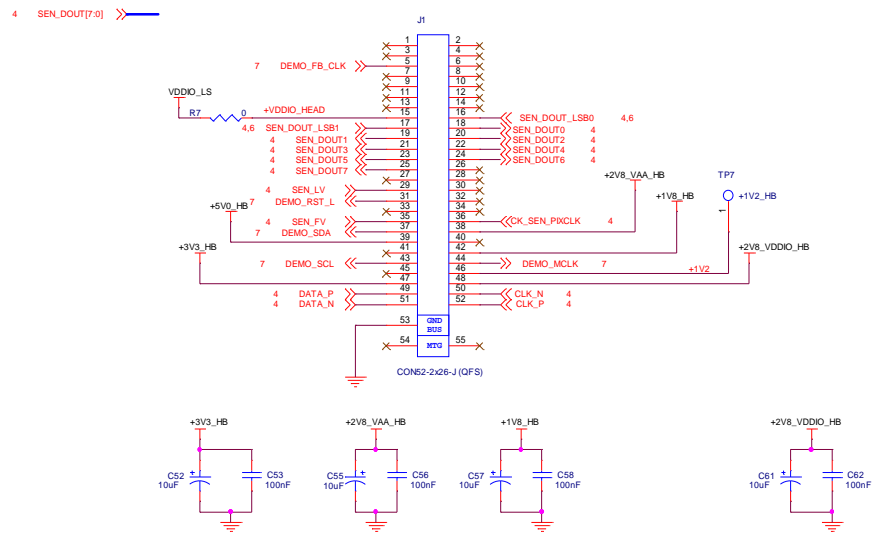

UART INTERFACE CIRCUIT

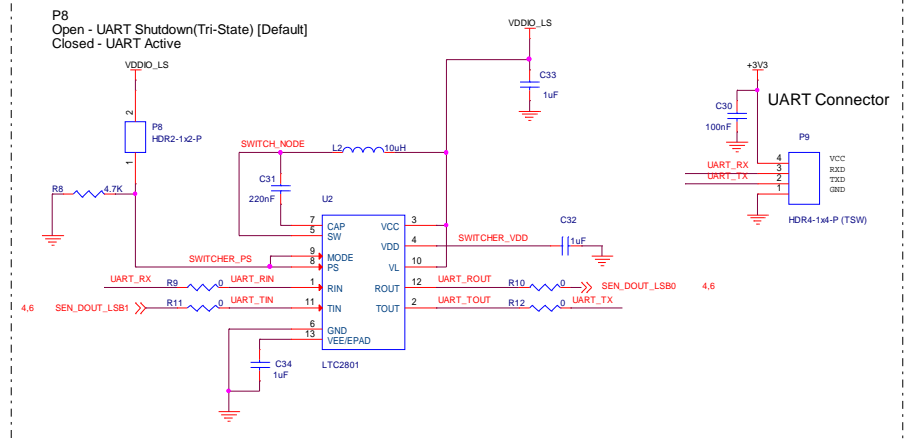

LENS CORRECTION EEPROM

Note: 24AA64-E/SN Serial EEPROM has speed limitation wrt voltage used. At 1.8V, only 100KHz operation of I2C is allowed and above 2.5V we can use 400KHz. So while implementing HT board, this has to be taken care of.

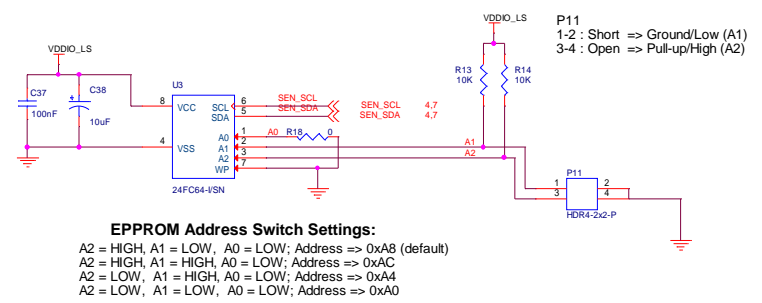

ON Semiconductor	
External Interface	
Doc ID	MT9M114_55CSP_Demo3_Headboard
Date:	Wednesday, November 04, 2015
Sheet	6 of 8
Rev	0.1

Clock & Reset

RESET CIRCUIT

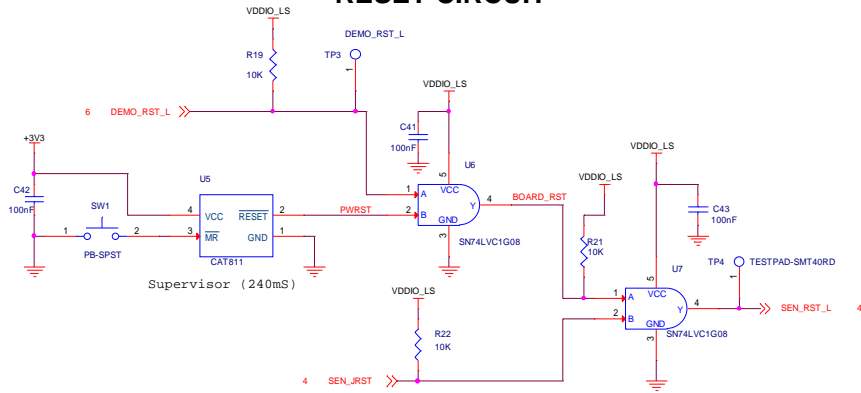

CLOCK CIRCUIT

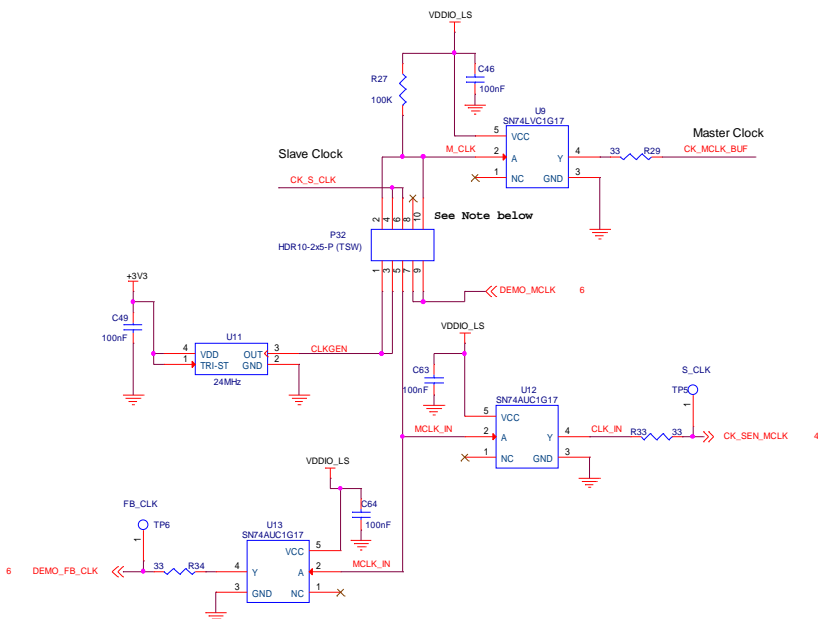

NOTE: P32 Oscillator Configurations
 3-5 -> Normal Single Camera Operation, using on board oscillator.
 5-7 -> Normal Single Camera Operator, using external clock from Demo3.
 3-5 & 1-2 -> Master in Multi-Camera Operation, oscillator to Slave Cameras (Default)
 5-6 -> Slave in Multi_Camera Operation, oscillator from Master Camera.
 5-6 & 2-4 -> Multi Slave in Multi_Camera Operation, oscillator from Master Camera.
 5-7 & 3-10 -> Master in Multi-Camera Operation, using external clock from Demo3.

Multi-Camera Interface

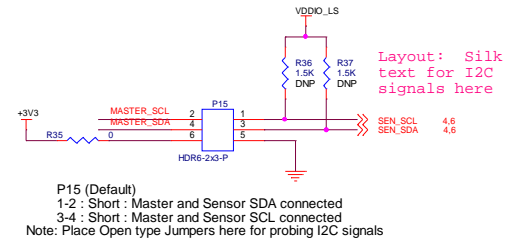

P15 (Default)
 1-2: Short: Master and Sensor SDA connected
 3-4: Short: Master and Sensor SCL connected
 Note: Place Open type Jumpers here for probing I2C signals

I2C Selection Switch for Master

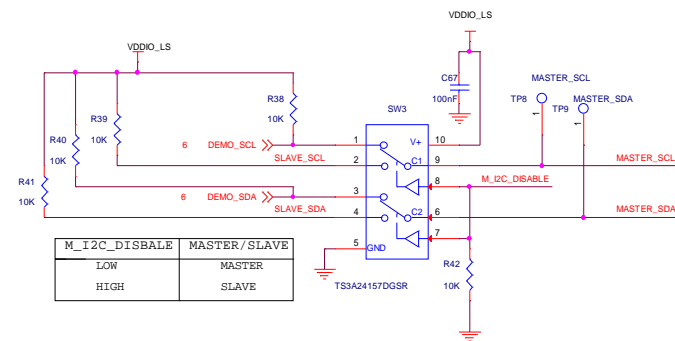

I2C Repeater for Master Slave Config

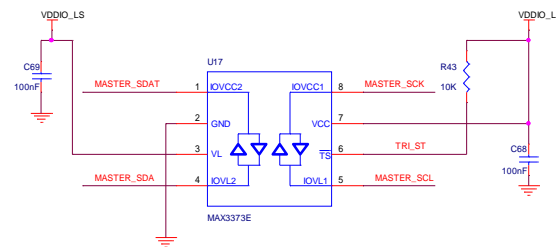

Master or Multi Slave Camera modes

- 1) Single Mode, No connection on both Master (P12) and Slave (P13) Connector
- 2) Multi-Camera Slave Mode, Slave Connector (P13) be connected to the Master Connector (P12) of Master Unit
- 3) Master Mode, Connect Master Connector (P12) to the Slave Connector (P13) of Slave Unit. No connection on the Master Unit's Slave Connector.



Master

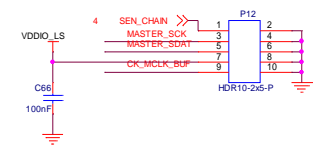

Slave

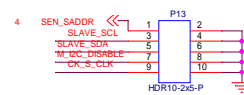

ON Semiconductor®

Title		MT9M114 (K24B)	
Doc ID	Document Name	MT9M114_55CSP_Demo3_Headboard	
Date:	Wednesday, November 04, 2015	Sheet	7 of 8
Rev	0.1		

Multi-Camera Configuration

Block diagram below shows cameras in a Multi-Camera Configuration

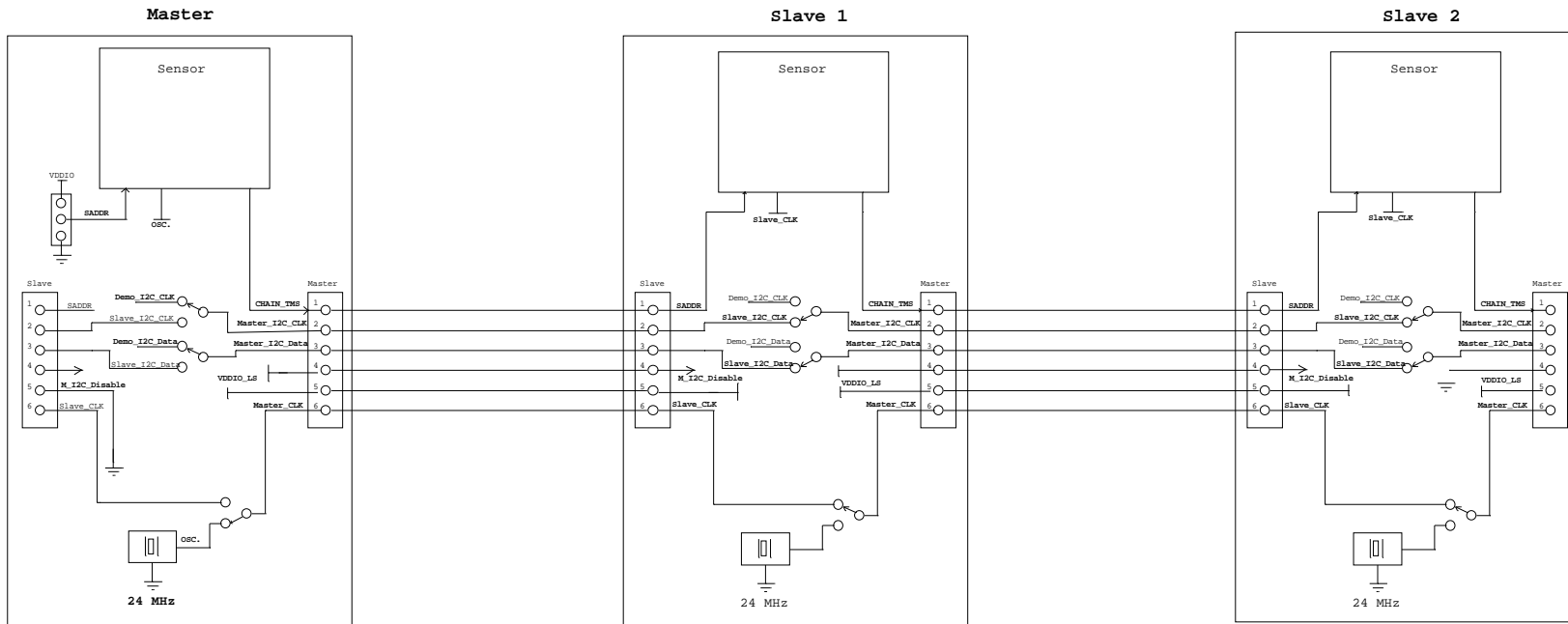

CLOCK DAISY CHAIN

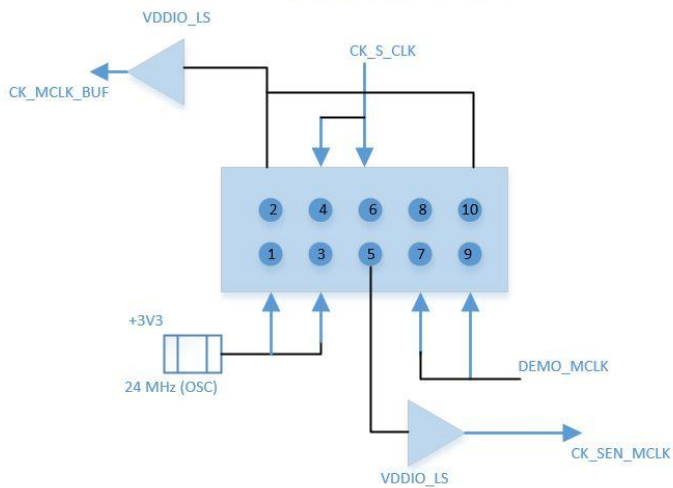

I2C DAISY CHAIN

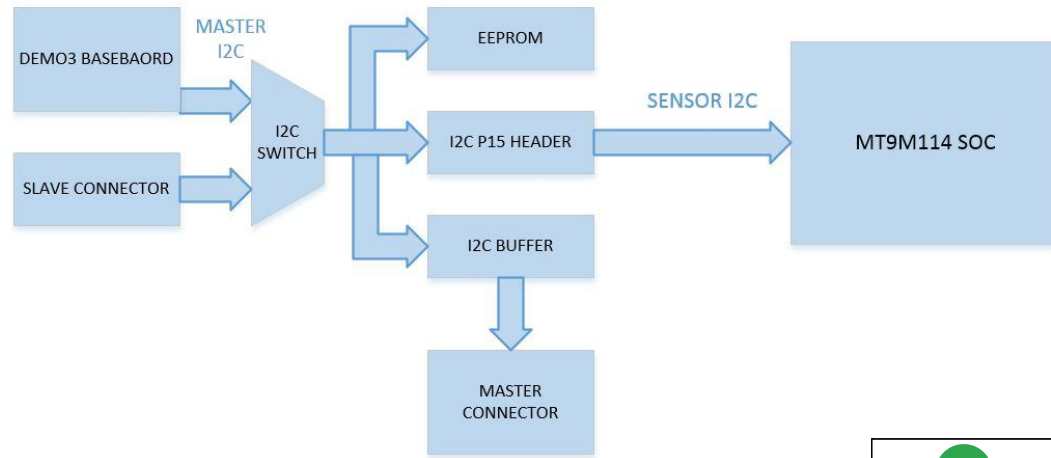

X-ON Electronics

Largest Supplier of Electrical and Electronic Components

Click to view similar products for [Optical Sensor Development Tools](#) category:

Click to view products by [ON Semiconductor](#) manufacturer:

Other Similar products are found below :

[AR0330CS1C12SPKAH3-GEVB](#) [MT9V034C12STCH-GEVB](#) [MT9V115EBKSTCH-GEVB](#) [416015300-3](#) [ISL29102IROZ-EVALZ](#)
[MT9M021IA3XTMH-GEVB](#) [AR1820HSSC12SHQAH3-GEVB](#) [AR1335CSSC11SMKAH3-GEVB](#) [MAXCAMOV10640#](#)
[MT9M031I12STMH-GEVB](#) [TSL2581CS-DB](#) [TMD3700-DB](#) [NANOUSB2.2](#) [ASX340AT3C00XPEDH3-GEVB](#) [AR0144ATSM20XUEAH3-GEVB](#) [AR0144CSSC00SUKAH3-GEVB](#) [AR0522SRSC09SURAH3-GEVB](#) [AR0522SRSM09SURAH3-GEVB](#) [AR0521SR2C09SURAH3-GEVB](#) [MARS1-MAX9295A-GEVK](#) [MARS1-MAX9296B-GEVB](#) [ISL29112IROZ-EVALZ](#) [AR0233AT2C17XUEAH3-GEVB](#)
[AR0431CSSC14SMRAH3-GEVB](#) [MARS-DEMO3-MIPI-GEVB](#) [TCS3430-DB](#) [AR0234CSSC00SUKAH3-GEVB](#) [AR0130CSSM00SPCAH-GEVB](#) [AR0330CM1C00SHAAH3-GEVB](#) [EVALZ-ADPD2212](#) [TMD2772EVM](#) [TMG3993EVM](#) [MIKROE-2103](#) [TSL2672EVM](#) [1384](#)
[MT9M114EBLSTCZDH-GEVB](#) [SEN0043](#) [SEN0162](#) [TMD2771EVM](#) [TMD3782EVM](#) [TSL4531EVM](#) [1918](#) [AS7225 DEMO KIT](#) [SEN0097](#)
[SEN0228](#) [AR0134CSSC00SUEAH3-GEVB](#) [AP0100AT2L00XUGAH3-GEVB](#) [AR0144CSSM20SUKAH3-GEVB](#) [725-28915](#) [EVAL-ADPD1081Z-PPG](#)