

NBSG16

2.5 V/3.3 V SiGe Differential Receiver/Driver with RSECL* Outputs

*Reduced Swing ECL

Description

The NBSG16 is a differential receiver/driver targeted for high frequency applications. The device is functionally equivalent to the EP16 and LVEP16 devices with much higher bandwidth and lower EMI capabilities.

Inputs incorporate internal 50 Ω termination resistors and accept NECL (Negative ECL), PECL (Positive ECL), HSTL, LVTTTL, LVCMOS, CML, or LVDS. Outputs are RSECL (Reduced Swing ECL), 400 mV.

The V_{BB} and V_{MM} pins are internally generated voltage supplies available to this device only. The V_{BB} is used as a reference voltage for single-ended NECL or PECL inputs and the V_{MM} pin is used as a reference voltage for LVCMOS inputs. For all single-ended input conditions, the unused complementary differential input is connected to V_{BB} or V_{MM} as a switching reference voltage. V_{BB} or V_{MM} may also rebias AC coupled inputs. When used, decouple V_{BB} and V_{MM} via a 0.01 μ F capacitor and limit current sourcing or sinking to 0.5 mA. When not used, V_{BB} and V_{MM} outputs should be left open.

Features

- Maximum Input Clock Frequency > 12 GHz Typical
- Maximum Input Data Rate > 12 Gb/s Typical
- 120 ps Typical Propagation Delay
- 40 ps Typical Rise and Fall Times
- RSPECL Output with Operating Range: $V_{CC} = 2.375$ V to 3.465 V with $V_{EE} = 0$ V
- RSNECL Output with RSNECL or NECL Inputs with Operating Range: $V_{CC} = 0$ V with $V_{EE} = -2.375$ V to -3.465 V
- RSECL Output Level (400 mV Peak-to-Peak Output), Differential Output Only
- 50 Ω Internal Input Termination Resistors
- Compatible with Existing 2.5 V/3.3 V LVEP, EP, and LVEL Devices
- V_{BB} and V_{MM} Reference Voltage Output
- These are Pb-Free Devices



ON Semiconductor®

<http://onsemi.com>



QFN-16
MN SUFFIX
CASE 485G

MARKING DIAGRAMS*

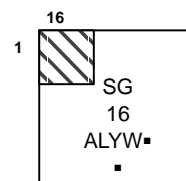

- A = Assembly Location
- L = Wafer Lot
- Y = Year
- W = Work Week
- = Pb-Free Package

(Note: Microdot may be in either location)

*For additional marking information, refer to Application Note AND8002/D.

ORDERING INFORMATION

See detailed ordering and shipping information in the package dimensions section on page 11 of this data sheet.

NBSG16

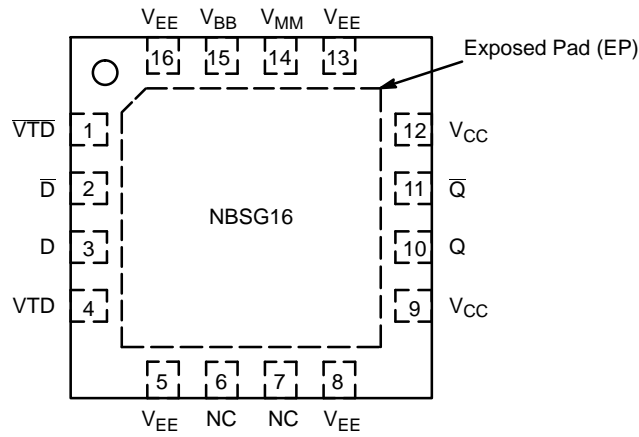

Figure 1. QFN-16 Pinout (Top View)

Table 1. PIN DESCRIPTION

Pin	Name	I/O	Description
1	$\overline{\text{VTD}}$	-	Internal 50 Ω Termination Pin. See Table 2.
2	$\overline{\text{D}}$	ECL, CML, LVCMOS, LVDS, LVTTTL Input	Inverted Differential Input. Internal 75 k Ω to V_{EE} and 36.5 k Ω to V_{CC} .
3	D	ECL, CML, LVCMOS, LVDS, LVTTTL Input	Noninverted differential input. Internal 75 k Ω to V_{EE}
4	VTD	-	Internal 50 Ω Termination Pin. See Table 2.
5, 8, 13, 16	V_{EE}	-	Negative Supply Voltage
6,7	NC	-	No Connect
9, 12	V_{CC}	-	Positive Supply Voltage
10	Q	RSECL Output	Noninverted Differential Output. Typically Terminated with 50 Ω to $V_{TT} = V_{CC} - 2 \text{ V}$
11	$\overline{\text{Q}}$	RSECL Output	Inverted Differential Output. Typically Terminated with 50 Ω to $V_{TT} = V_{CC} - 2 \text{ V}$
14	V_{MM}	-	LVCMOS Reference Voltage Output. $(V_{CC} - V_{EE})/2$
15	V_{BB}	-	ECL Reference Voltage Output
-	EP	-	The Exposed Pad (EP) on the QFN-16 package bottom is thermally connected to the die for improved heat transfer out of package. The exposed pad must be attached to a heat-sinking conduit. The pad is not electrically connected to the die but may be electrically and thermally connected to V_{EE} on the PC board.

1. All V_{CC} and V_{EE} pins must be externally connected to Power Supply to guarantee proper operation. The thermally exposed pad on package bottom (see case drawing) must be attached to a heat-sinking conduit.
2. In the differential configuration when the input termination pins (VTD, $\overline{\text{VTD}}$) are connected to a common termination voltage, and if no signal is applied then the device will be susceptible to self-oscillation.

NBSG16

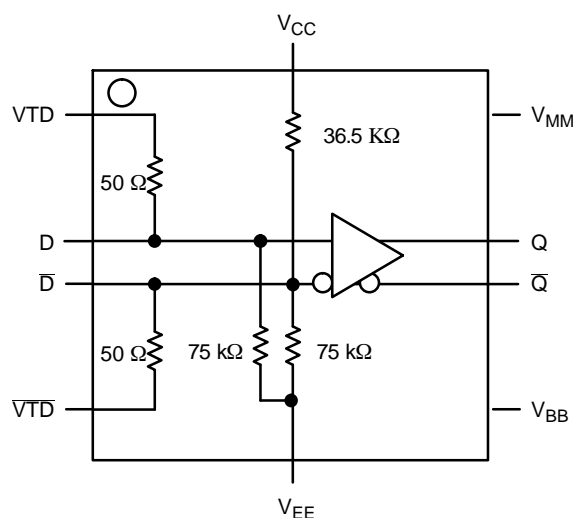

Figure 2. Logic Diagram

Table 2. INTERFACING OPTIONS

INTERFACING OPTIONS	CONNECTIONS
CML	Connect VTD and VTD-bar to V _{CC}
LVDS	Connect VTD and VTD-bar together
AC-COUPLED	Bias VTD and VTD-bar Inputs within (V _{IHCMR}) Common Mode Range
RSECL, PECL, NECL	Standard ECL Termination Techniques
LVTTTL	The external voltage should be applied to the unused complementary differential input. Nominal voltage is 1.5 V for LVTTTL.
LVC MOS	V _{MM} should be connected to the unused complementary differential input.

Table 3. ATTRIBUTES

Characteristics	Value
Internal Input Pulldown Resistor (D, D-bar)	75 kΩ
Internal Input Pullup Resistor (D-bar)	36.5 kΩ
ESD Protection	Human Body Model Machine Model
	> 2 kV > 100 V
Moisture Sensitivity (Note 3)	Pb-Free
	Level 1
Flammability Rating	Oxygen Index: 28 to 34
	UL 94 V-0 @ 0.125 in
Transistor Count	167
Meets or exceeds JEDEC Spec EIA/JESD78 IC Latchup Test	

3. For additional information, see Application Note AND8003/D.

NBSG16

Table 4. MAXIMUM RATINGS

Symbol	Parameter	Condition 1	Condition 2	Rating	Unit
V_{CC}	Positive Power Supply	$V_{EE} = 0\text{ V}$		3.6	V
V_{EE}	Negative Power Supply	$V_{CC} = 0\text{ V}$		-3.6	V
V_I	Positive Input Negative Input	$V_{EE} = 0\text{ V}$ $V_{CC} = 0\text{ V}$	$V_I \leq V_{CC}$ $V_I \geq V_{EE}$	3.6 -3.6	V V
V_{INPP}	Differential Input Voltage $ D - \bar{D} $	$V_{CC} - V_{EE} \geq 2.8\text{ V}$ $V_{CC} - V_{EE} < 2.8\text{ V}$		2.8 $ V_{CC} - V_{EE} $	V
I_{out}	Output Current	Continuous Surge		25 50	mA
I_{BB}	V_{BB} Sink/Source			1	mA
I_{MM}	V_{MM} Sink/Source			1	mA
T_A	Operating Temperature Range			-40 to +85	°C
T_{stg}	Storage Temperature Range			-65 to +150	°C
θ_{JA}	Thermal Resistance (Junction-to-Ambient) (Note 4)	0 lfpm 500 lfpm		41.6 35.2	°C/W
θ_{JC}	Thermal Resistance (Junction-to-Case)	2S2P (Note 4)		4.0	°C/W
T_{sol}	Wave Solder Pb-Free			265	°C

Stresses exceeding those listed in the Maximum Ratings table may damage the device. If any of these limits are exceeded, device functionality should not be assumed, damage may occur and reliability may be affected.

4. JEDEC standard multilayer board – 2S2P (2 signal, 2 power) with 8 filled thermal vias under exposed pad.

NBSG16

Table 5. DC CHARACTERISTICS, INPUT WITH RSPECL OUTPUT

($V_{CC} = 2.5\text{ V}$; $V_{EE} = 0\text{ V}$) (Note 5)

Symbol	Characteristic	-40°C			25°C			85°C			Unit
		Min	Typ	Max	Min	Typ	Max	Min	Typ	Max	

POWER SUPPLY CURRENT

I_{EE}	Negative Power Supply Current	17	23	29	17	23	29	17	23	29	mA
----------	-------------------------------	----	----	----	----	----	----	----	----	----	----

RSPECL OUTPUTS (Note 6)

V_{OH}	Output HIGH Voltage	1450	1530	1575	1525	1565	1600	1550	1590	1625	mV
V_{OUTPP}	Output Voltage Amplitude	350	410	525	350	410	525	350	410	525	mV

DIFFERENTIAL CLOCK INPUTS DRIVEN SINGLE-ENDED (Figures 5 & 7) (Note 7)

V_{IH}	Input HIGH Voltage	1200		V_{CC}	1200		V_{CC}	1200		V_{CC}	mV
V_{IL}	Input LOW Voltage	0		$V_{IH} - 150$	0		$V_{IH} - 150$	0		$V_{IH} - 150$	mV
V_{th}	Input Threshold Voltage Range (Note 8)	950		$V_{CC} - 75$	950		$V_{CC} - 75$	950		$V_{CC} - 75$	mV
V_{ISE}	Single-Ended Input Voltage ($V_{IH} - V_{IL}$)	150		2600	150		2600	150		260	mV
V_{BB}	PECL Output Voltage Reference	1080	1140	1200	1080	1140	1200	1080	1140	1200	mV

DIFFERENTIAL INPUTS DRIVEN DIFFERENTIALLY (Figures 6 & 8) (Note 9)

V_{IHD}	Differential Input HIGH Voltage	1200		V_{CC}	1200		V_{CC}	1200		V_{CC}	mV
V_{ILD}	Differential Input LOW Voltage	0		$V_{IHD} - 75$	0		$V_{IHD} - 75$	0		$V_{IHD} - 75$	mV
V_{ID}	Differential Input Voltage ($V_{IHD} - V_{ILD}$)	75		2600	75		2600	75		2600	mV
V_{IHCMR}	Input HIGH Voltage Common Mode Range (Note 10) (Figure 9)	1200		2500	1200		2500	1200		2500	mV
I_{IH}	Input HIGH Current (@ V_{IH})		30	100		30	100		30	100	μA
I_{IL}	Input LOW Current (@ V_{IL})		25	50		25	50		25	50	μA

LVC MOS CONTROL PIN

V_{MM}	CMOS Output Voltage Reference $V_{CC}/2$	1100	1250	1400	1100	1250	1400	1100	1250	1400	mV
----------	------------------------------------------	------	------	------	------	------	------	------	------	------	----

TERMINATION RESISTORS

R_{TIN}	Internal Input Termination Resistor	45	50	55	45	50	55	45	50	55	Ω
-----------	-------------------------------------	----	----	----	----	----	----	----	----	----	----------

Product parametric performance is indicated in the Electrical Characteristics for the listed test conditions, unless otherwise noted. Product performance may not be indicated by the Electrical Characteristics if operated under different conditions.

NOTE: Device will meet the specifications after thermal equilibrium has been established when mounted in a test socket or printed circuit board with maintained transverse airflow greater than 500 lpm. Electrical parameters are guaranteed only over the declared operating temperature range. Functional operation of the device exceeding these conditions is not implied. Device specification limit values are applied individually under normal operating conditions and not valid simultaneously.

5. Input and output parameters vary 1:1 with V_{CC} .
6. All loading with 50 Ω to $V_{CC} - 2.0\text{ V}$.
7. V_{th} , V_{IH} , V_{IL} and V_{ISE} parameters must be complied with simultaneously.
8. V_{th} is applied to the complementary input when operating in single-ended mode. $V_{th} = (V_{IH} - V_{IL}) / 2$.
9. V_{IHD} , V_{ILD} , V_{ID} and V_{IHCMR} parameters must be complied with simultaneously.
10. V_{IHCMR} min varies 1:1 with V_{EE} , V_{IHCMR} max varies 1:1 with V_{CC} . The V_{IHCMR} range is referenced to the most positive side of the differential input signal.

NBSG16

Table 6. DC CHARACTERISTICS, INPUT WITH RSPECL OUTPUT

($V_{CC} = 3.3\text{ V}$; $V_{EE} = 0\text{ V}$) (Note 11)

Symbol	Characteristic	-40°C			25°C			85°C			Unit
		Min	Typ	Max	Min	Typ	Max	Min	Typ	Max	

POWER SUPPLY CURRENT

I_{EE}	Negative Power Supply Current	17	23	29	17	23	29	17	23	29	mA
----------	-------------------------------	----	----	----	----	----	----	----	----	----	----

RSPECL OUTPUTS (Note 12)

V_{OH}	Output HIGH Voltage	2250	2330	2375	2325	2365	2400	2350	2390	2425	mV
V_{OUTPP}	Output Voltage Amplitude	350	410	525	350	410	525	350	410	525	mV

DIFFERENTIAL CLOCK INPUTS DRIVEN SINGLE-ENDED (Figures 5 & 7) (Note 13)

V_{IH}	Input HIGH Voltage	1200		V_{CC}	1200		V_{CC}	1200		V_{CC}	mV
V_{IL}	Input LOW Voltage	0		$V_{IH} - 150$	0		$V_{IH} - 150$	0		$V_{IH} - 150$	mV
V_{th}	Input Threshold Voltage Range (Note 14)	950		$V_{CC} - 75$	950		$V_{CC} - 75$	950		$V_{CC} - 75$	mV
V_{ISE}	Single-Ended Input Voltage ($V_{IH} - V_{IL}$)	150		2600	150		2600	150		260	mV
V_{BB}	PECL Output Voltage Reference	1880	1940	2000	1880	1940	2000	1880	1940	2000	mV

DIFFERENTIAL INPUTS DRIVEN DIFFERENTIALLY (Figures 6 & 8) (Note 15)

V_{IHD}	Differential Input HIGH Voltage	1200		V_{CC}	1200		V_{CC}	1200		V_{CC}	mV
V_{ILD}	Differential Input LOW Voltage	0		$V_{IHD} - 75$	0		$V_{IHD} - 75$	0		$V_{IHD} - 75$	mV
V_{ID}	Differential Input Voltage ($V_{IHD} - V_{ILD}$)	75		2600	75		2600	75		2600	mV
V_{IHCMR}	Input HIGH Voltage Common Mode Range (Note 16) (Figure 9)	1200		3300	1200		3300	1200		3300	mV
I_{IH}	Input HIGH Current (@ V_{IH})		30	100		30	100		30	100	μA
I_{IL}	Input LOW Current (@ V_{IL})		25	50		25	50		25	50	μA

LVC MOS CONTROL PIN

V_{MM}	CMOS Output Voltage Reference $V_{CC}/2$	1500	1650	1800	1500	1650	1800	1500	1650	1800	mV
----------	------------------------------------------	------	------	------	------	------	------	------	------	------	----

TERMINATION RESISTORS

R_{TIN}	Internal Input Termination Resistor	45	50	55	45	50	55	45	50	55	Ω
-----------	-------------------------------------	----	----	----	----	----	----	----	----	----	----------

Product parametric performance is indicated in the Electrical Characteristics for the listed test conditions, unless otherwise noted. Product performance may not be indicated by the Electrical Characteristics if operated under different conditions.

NOTE: Device will meet the specifications after thermal equilibrium has been established when mounted in a test socket or printed circuit board with maintained transverse airflow greater than 500 lpm. Electrical parameters are guaranteed only over the declared operating temperature range. Functional operation of the device exceeding these conditions is not implied. Device specification limit values are applied individually under normal operating conditions and not valid simultaneously.

11. Input and output parameters vary 1:1 with V_{CC} .

12. All loading with $50\ \Omega$ to $V_{CC} - 2.0\text{ V}$.

13. V_{th} , V_{IH} , V_{IL} and V_{ISE} parameters must be complied with simultaneously.

14. V_{th} is applied to the complementary input when operating in single-ended mode. $V_{th} = (V_{IH} - V_{IL}) / 2$.

15. V_{IHD} , V_{ILD} , V_{ID} and V_{IHCMR} parameters must be complied with simultaneously.

16. V_{IHCMR} min varies 1:1 with V_{EE} , V_{IHCMR} max varies 1:1 with V_{CC} . The V_{IHCMR} range is referenced to the most positive side of the differential input signal.

NBSG16

Table 7. DC CHARACTERISTICS, NECL or RSNECL INPUT WITH NECL OUTPUT

($V_{CC} = 0\text{ V}$; $V_{EE} = -3.465\text{ V}$ to -2.375 V) (Note 17)

Symbol	Characteristic	-40°C			25°C			85°C			Unit
		Min	Typ	Max	Min	Typ	Max	Min	Typ	Max	

POWER SUPPLY CURRENT

I_{EE}	Negative Power Supply Current	17	23	29	17	23	29	17	23	29	mA
----------	-------------------------------	----	----	----	----	----	----	----	----	----	----

RSPECL OUTPUTS (Note 18)

V_{OH}	Output HIGH Voltage	-1050	-970	-925	-975	-935	-900	-950	-910	-875	mV
V_{OUTPP}	Output Voltage Amplitude	350	410	525	350	410	525	350	410	525	mV

DIFFERENTIAL CLOCK INPUTS DRIVEN SINGLE-ENDED (Figures 5 & 7) (Note 19)

V_{IH}	Input HIGH Voltage	$V_{EE} + 1200$		V_{CC}	$V_{EE} + 1200$		V_{CC}	$V_{EE} + 1200$		V_{CC}	mV
V_{IL}	Input LOW Voltage	V_{EE}		$V_{IH} - 150$	V_{EE}		$V_{IH} - 150$	V_{EE}		$V_{IH} - 150$	mV
V_{th}	Input Threshold Voltage Range (Note 20)	$V_{EE} + 950$		$V_{CC} - 75$	$V_{EE} + 950$		$V_{CC} - 75$	$V_{EE} + 950$		$V_{CC} - 75$	mV
V_{ISE}	Single-Ended Input Voltage ($V_{IH} - V_{IL}$)	150		2600	150		2600	150		260	mV
V_{BB}	NECL Output Voltage Reference	-1420	-1360	-1300	-1420	-1360	-1300	-1420	-1360	-1300	mV

DIFFERENTIAL INPUTS DRIVEN DIFFERENTIALLY (Figures 6 & 8) (Note 21)

V_{IHD}	Differential Input HIGH Voltage	$V_{EE} + 1200$		V_{CC}	$V_{EE} + 1200$		V_{CC}	$V_{EE} + 1200$		V_{CC}	mV
V_{ILD}	Differential Input LOW Voltage	V_{EE}		$V_{IHD} - 75$	V_{EE}		$V_{IHD} - 75$	V_{EE}		$V_{IHD} - 75$	mV
V_{ID}	Differential Input Voltage ($V_{IHD} - V_{ILD}$)	75		2600	75		2600	75		2600	mV
V_{IHCMR}	Input HIGH Voltage Common Mode Range (Note 22) (Figure 9)	$V_{EE} + 1200$		0	$V_{EE} + 1200$		0	$V_{EE} + 1200$		0	mV
I_{IH}	Input HIGH Current (@ V_{IH})		30	100		30	100		30	100	μA
I_{IL}	Input LOW Current (@ V_{IL})		25	50		25	50		25	50	μA

LVC MOS CONTROL PIN (Note 23)

V_{MM}	CMOS Output Voltage Reference $V_{CC}/2$	$V_{MM} - 150$	V_{MM}	$V_{MM} + 150$	$V_{MM} - 150$	V_{MM}	$V_{MM} + 150$	$V_{MM} - 150$	V_{MM}	$V_{MM} + 150$	mV
----------	------------------------------------------	----------------	----------	----------------	----------------	----------	----------------	----------------	----------	----------------	----

TERMINATION RESISTORS

R_{TIN}	Internal Input Termination Resistor	45	50	55	45	50	55	45	50	55	Ω
-----------	-------------------------------------	----	----	----	----	----	----	----	----	----	----------

Product parametric performance is indicated in the Electrical Characteristics for the listed test conditions, unless otherwise noted. Product performance may not be indicated by the Electrical Characteristics if operated under different conditions.

NOTE: Device will meet the specifications after thermal equilibrium has been established when mounted in a test socket or printed circuit board with maintained transverse airflow greater than 500 lfm. Electrical parameters are guaranteed only over the declared operating temperature range. Functional operation of the device exceeding these conditions is not implied. Device specification limit values are applied individually under normal operating conditions and not valid simultaneously.

17. Input and output parameters vary 1:1 with V_{CC} .

18. All loading with $50\ \Omega$ to $V_{CC} - 2.0\text{ V}$.

19. V_{th} , V_{IH} , V_{IL} , and V_{ISE} parameters must be complied with simultaneously.

20. V_{th} is applied to the complementary input when operating in single-ended mode. $V_{th} = (V_{IH} - V_{IL}) / 2$.

21. V_{IHD} , V_{ILD} , V_{ID} and V_{IHCMR} parameters must be complied with simultaneously.

22. V_{IHCMR} min varies 1:1 with V_{EE} , V_{IHCMR} max varies 1:1 with V_{CC} . The V_{IHCMR} range is referenced to the most positive side of the differential input signal.

23. V_{MM} typical = $|V_{CC} - V_{EE}|/2 + V_{EE} = V_{MMT}$

NBSG16

Table 8. AC CHARACTERISTICS

($V_{CC} = 0\text{ V}$; $V_{EE} = -3.465\text{ V}$ to -2.375 V or $V_{CC} = 2.375\text{ V}$ to 3.465 V ; $V_{EE} = 0\text{ V}$)

Symbol	Characteristic	-40°C			25°C			85°C			Unit
		Min	Typ	Max	Min	Typ	Max	Min	Typ	Max	
f_{\max}	Maximum Input Clock Frequency (See Figure 3. f_{\max}/JITTER) (Note 24)	10.7	12		10.7	12		10.7	12		GHz
t_{PLH} , t_{PHL}	Propagation Delay to Output Differential	90	110	130	100	120	140	95	125	145	ps
t_{SKEW}	Duty Cycle Skew (Note 25)		3	15		3	15		3	15	ps
t_{JITTER}	RMS Random Clock Jitter Peak-to-Peak Data Dependent Jitter		0.2	2		0.2	2		0.2	2	ps
	$f_{\text{in}} < 10\text{ GHz}$		0.2	2		0.2	2		0.2	2	ps
	$f_{\text{in}} < 10\text{ Gb/s}$		8			8			8		ps
V_{INPP}	Input Voltage Swing/Sensitivity (Differential Configuration) (Note 26)	75		2600	75		2600	75		2600	mV
t_r t_f	Output Rise/Fall Times @ 1 GHz (20% – 80%) Q, \bar{Q}	20	30	50	20	30	50	20	30	50	ps

NOTE: Device will meet the specifications after thermal equilibrium has been established when mounted in a test socket or printed circuit board with maintained transverse airflow greater than 500 lfpm. Electrical parameters are guaranteed only over the declared operating temperature range. Functional operation of the device exceeding these conditions is not implied. Device specification limit values are applied individually under normal operating conditions and not valid simultaneously.

24. Measured using a 400 mV source, 50% duty cycle clock source. All loading with $50\ \Omega$ to $V_{CC} - 2.0\text{ V}$. Input edge rates 40 ps (20% – 80%).

25. See Figure 10. $t_{\text{skew}} = |t_{\text{PLH}} - t_{\text{PHL}}|$ for a nominal 50% differential clock input waveform.

26. $V_{\text{INPP(max)}}$ cannot exceed $V_{CC} - V_{EE}$

NBSG16

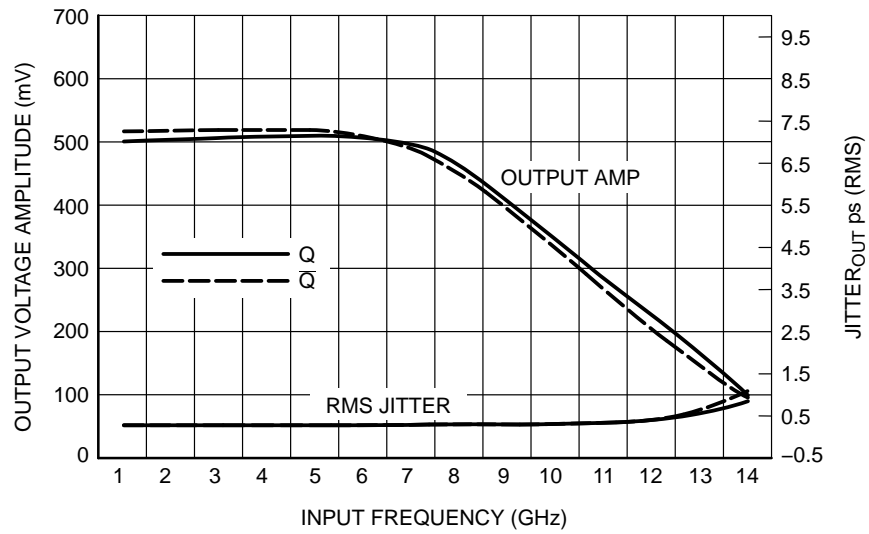
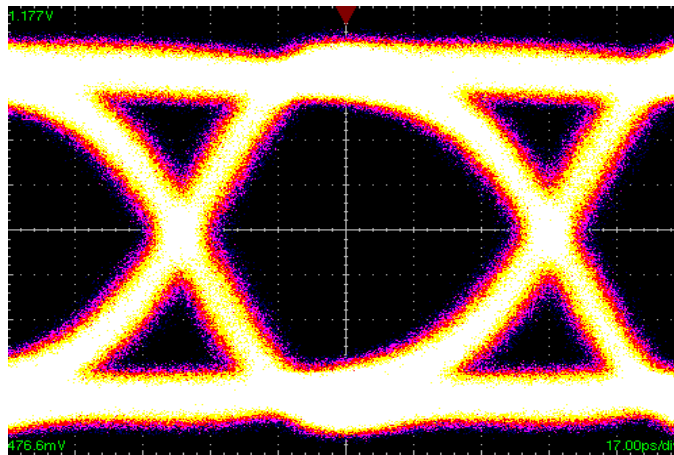

Figure 3. Output Voltage Amplitude (V_{OUTPP}) / RMS Jitter vs. Input Frequency (f_{in}) at Ambient Temperature (Typical)



X = 17ps/Div Y = 70 mV/Div

Figure 4. 10.709 Gb/s Diagram (3.0 V, 25°C)

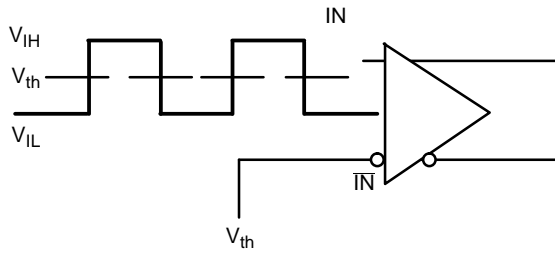

Figure 5. Differential Input Driven Single-Ended

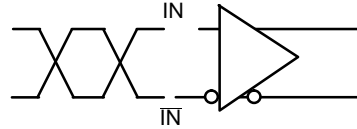

Figure 6. Differential Inputs Driven Differentially

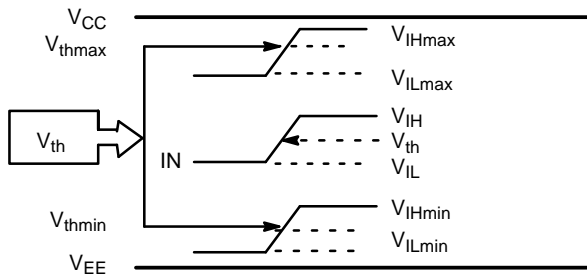

Figure 7. V_{th} Diagram

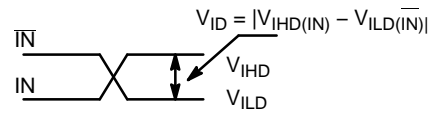

Figure 8. Differential Inputs Driven Differentially

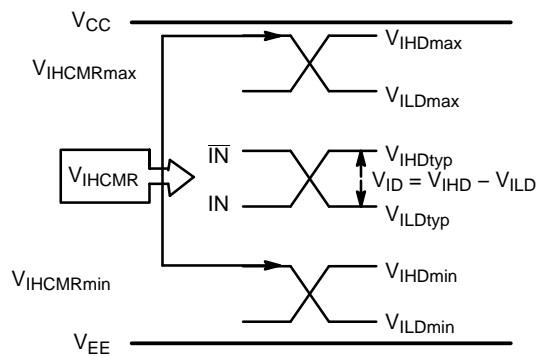

Figure 9. V_{IHCMR} Diagram

NBSG16

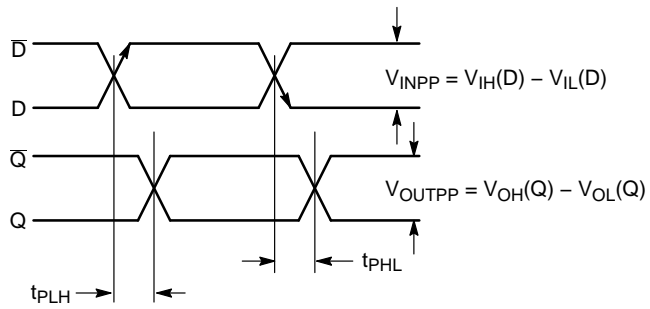
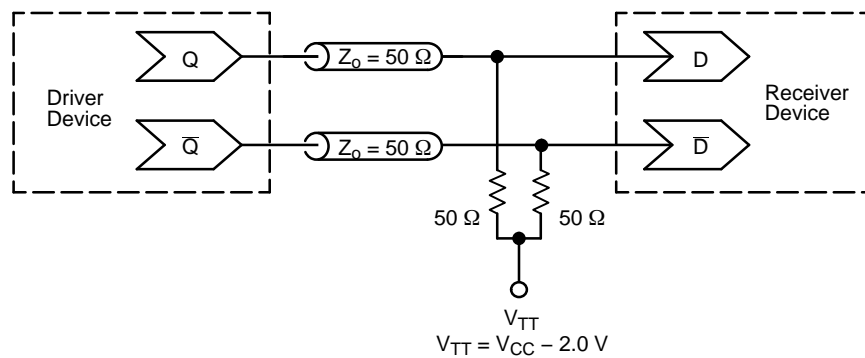

Figure 10. AC Reference Measurement



**Figure 11. Typical Termination for Output Driver and Device Evaluation
(See Application Note AND8020/D – Termination of ECL Logic Devices.)**

ORDERING INFORMATION

Device	Package	Shipping†
NBSG16MNG	QFN-16 (Pb-Free / Halide-Free)	123 Units / Tube
NBSG16MNR2G	QFN-16 (Pb-Free / Halide-Free)	3000 / Tape & Reel
NBSG16MNHTBG	QFN-16 (Pb-Free / Halide-Free)	100 / Tape & Reel

†For information on tape and reel specifications, including part orientation and tape sizes, please refer to our Tape and Reel Packaging Specifications Brochure, BRD8011/D.

MECHANICAL CASE OUTLINE

PACKAGE DIMENSIONS

ON Semiconductor®



1
SCALE 2:1

QFN16 3x3, 0.5P
CASE 485G-01
ISSUE F

DATE 22 JUN 2011

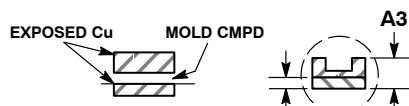
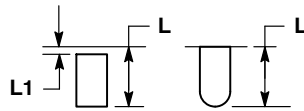
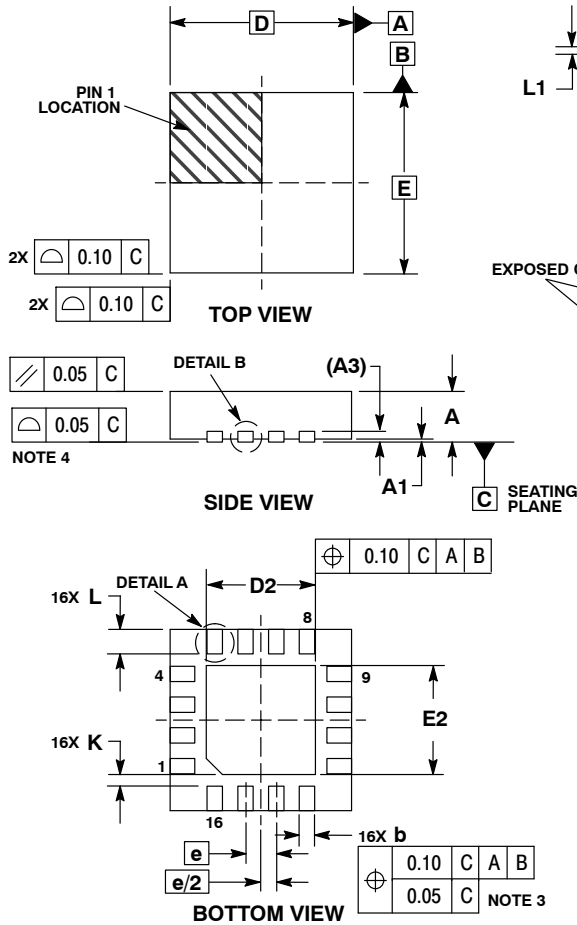

- NOTES:
- DIMENSIONING AND TOLERANCING PER ASME Y14.5M, 1994.
 - CONTROLLING DIMENSION: MILLIMETERS.
 - DIMENSION b APPLIES TO PLATED TERMINAL AND IS MEASURED BETWEEN 0.25 AND 0.30 MM FROM TERMINAL.
 - COPLANARITY APPLIES TO THE EXPOSED PAD AS WELL AS THE TERMINALS.

MILLIMETERS			
DIM	MIN	NOM	MAX
A	0.80	0.90	1.00
A1	0.00	0.03	0.05
A3	0.20 REF		
b	0.18	0.24	0.30
D	3.00 BSC		
D2	1.65	1.75	1.85
E	3.00 BSC		
E2	1.65	1.75	1.85
e	0.50 BSC		
K	0.18 TYP		
L	0.30	0.40	0.50
L1	0.00	0.08	0.15

GENERIC MARKING DIAGRAM*

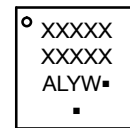

- XXXXX = Specific Device Code
- A = Assembly Location
- L = Wafer Lot
- Y = Year
- W = Work Week
- = Pb-Free Package

(Note: Microdot may be in either location)

*This information is generic. Please refer to device data sheet for actual part marking. Pb-Free indicator, "G" or microdot "▪", may or may not be present.

RECOMMENDED SOLDERING FOOTPRINT*

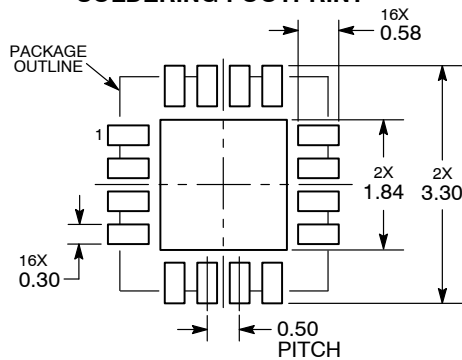

*For additional information on our Pb-Free strategy and soldering details, please download the ON Semiconductor Soldering and Mounting Techniques Reference Manual, SOLDERRM/D.

DOCUMENT NUMBER:	98AON04795D	Electronic versions are uncontrolled except when accessed directly from the Document Repository. Printed versions are uncontrolled except when stamped "CONTROLLED COPY" in red.
DESCRIPTION:	QFN16, 3X3 MM, 0.5 PITCH	PAGE 1 OF 1

ON Semiconductor and ON are trademarks of Semiconductor Components Industries, LLC dba ON Semiconductor or its subsidiaries in the United States and/or other countries. ON Semiconductor reserves the right to make changes without further notice to any products herein. ON Semiconductor makes no warranty, representation or guarantee regarding the suitability of its products for any particular purpose, nor does ON Semiconductor assume any liability arising out of the application or use of any product or circuit, and specifically disclaims any and all liability, including without limitation special, consequential or incidental damages. ON Semiconductor does not convey any license under its patent rights nor the rights of others.

ON Semiconductor and  are trademarks of Semiconductor Components Industries, LLC dba ON Semiconductor or its subsidiaries in the United States and/or other countries. ON Semiconductor owns the rights to a number of patents, trademarks, copyrights, trade secrets, and other intellectual property. A listing of ON Semiconductor's product/patent coverage may be accessed at www.onsemi.com/site/pdf/Patent-Marking.pdf. ON Semiconductor reserves the right to make changes without further notice to any products herein. ON Semiconductor makes no warranty, representation or guarantee regarding the suitability of its products for any particular purpose, nor does ON Semiconductor assume any liability arising out of the application or use of any product or circuit, and specifically disclaims any and all liability, including without limitation special, consequential or incidental damages. Buyer is responsible for its products and applications using ON Semiconductor products, including compliance with all laws, regulations and safety requirements or standards, regardless of any support or applications information provided by ON Semiconductor. "Typical" parameters which may be provided in ON Semiconductor data sheets and/or specifications can and do vary in different applications and actual performance may vary over time. All operating parameters, including "Typicals" must be validated for each customer application by customer's technical experts. ON Semiconductor does not convey any license under its patent rights nor the rights of others. ON Semiconductor products are not designed, intended, or authorized for use as a critical component in life support systems or any FDA Class 3 medical devices or medical devices with a same or similar classification in a foreign jurisdiction or any devices intended for implantation in the human body. Should Buyer purchase or use ON Semiconductor products for any such unintended or unauthorized application, Buyer shall indemnify and hold ON Semiconductor and its officers, employees, subsidiaries, affiliates, and distributors harmless against all claims, costs, damages, and expenses, and reasonable attorney fees arising out of, directly or indirectly, any claim of personal injury or death associated with such unintended or unauthorized use, even if such claim alleges that ON Semiconductor was negligent regarding the design or manufacture of the part. ON Semiconductor is an Equal Opportunity/Affirmative Action Employer. This literature is subject to all applicable copyright laws and is not for resale in any manner.

PUBLICATION ORDERING INFORMATION

LITERATURE FULFILLMENT:

Email Requests to: orderlit@onsemi.com

ON Semiconductor Website: www.onsemi.com

TECHNICAL SUPPORT

North American Technical Support:
Voice Mail: 1 800-282-9855 Toll Free USA/Canada
Phone: 011 421 33 790 2910

Europe, Middle East and Africa Technical Support:

Phone: 00421 33 790 2910

For additional information, please contact your local Sales Representative

X-ON Electronics

Largest Supplier of Electrical and Electronic Components

Click to view similar products for ON Semiconductor manufacturer:

Other Similar products are found below :

[1.5SMC82AT3G](#) [74LCX574WM](#) [STK621-068C-E](#) [NBXSBA017LN1TAG](#) [KAF-3200-ABA-CP-B2](#) [STK621-728S-E](#) [AMIS30621AUA](#)
[STK531U340A-E](#) [STK760-304-E](#) [FJAF6810DTU](#) [DBD250G](#) [STK621-713-E](#) [TIP115](#) [LB11847-E](#) [NBXHBA017LN1TAG](#) [LV8736V-MPB-](#)
[H](#) [NCP694H12HT1G](#) [LA4631VC-XE](#) [CAT1025WI-25-G](#) [NDF04N60ZG-001](#) [LA78040B-S-E](#) [LA6584M-MPB-E](#) [NVB60N06T4G](#)
[LA6245P-CL-TLM-E](#) [STK621-043D-E](#) [BTA30H-600CW3G](#) [P6SMB100AT3G](#) [NCP1129AP100G](#) [LV8406T-TLM-E](#) [MC100EL13DWG](#)
[FW217A-TL-2WX](#) [MC33201DG](#) [KA78L05AZTA](#) [FST3126MX](#) [LV4904V-MPB-E](#) [STK672-400](#) [SBM30-03-TR-E](#) [NCP1398BDR2G](#)
[BTA25H-600CW3G](#) [LC89057W-VF4A-E](#) [CPH6531-TL-E](#) [NCP4683DSQ28T1G](#) [MC78L08ACP](#) [SA5230DR2G](#) [NCP694D25HT1G](#)
[CAT25020VE-GT3](#) [MC10EP142FAG](#) [CAT1832L-G](#) [CAT93C56VP2I-GT3](#) [NCP4625DSN50T1G](#)