

NBSG16M

2.5 V/3.3 V Multilevel Input to CML Clock/Data Receiver/Driver/Translator Buffer

Description

The NBSG16M is a differential current mode logic (CML) receiver/driver/translator buffer. The device is functionally equivalent to the EP16, LVEP16, or SG16 devices with CML output structure and lower EMI capabilities.

Inputs incorporate internal 50 Ω termination resistors and accept LVNECL (Negative ECL), LVPECL (Positive ECL), LVTTTL, LVCMOS, CML, or LVDS. The CML output structure contains internal 50 Ω source termination resistor to V_{CC} . The device generates 400 mV output amplitude with 50 Ω receiver resistor to V_{CC} .

The V_{BB} pin is internally generated voltage supply available to this device only. For all single-ended input conditions, the unused complementary differential input is connected to V_{BB} as a switching reference voltage. V_{BB} may also rebias AC coupled inputs. When used, decouple V_{BB} via a 0.01 μ F capacitor and limit current sourcing or sinking to 0.5 mA. When not used, V_{BB} output should be left open.

Features

- Maximum Input Clock Frequency > 10 GHz Typical
- Maximum Input Data Rate > 10 Gb/s Typical
- 120 ps Typical Propagation Delay
- 35 ps Typical Rise and Fall Times
- Positive CML Output with Operating Range:
 $V_{CC} = 2.375$ V to 3.465 V with $V_{EE} = 0$ V
- Negative CML Output with RSNECL or NECL Inputs with
Operating Range: $V_{CC} = 0$ V with $V_{EE} = -2.375$ V to -3.465 V
- CML Output Level; 400 mV Peak-to-Peak Output with
50 Ω Receiver Resistor to V_{CC}
- 50 Ω Internal Input and Output Termination Resistors
- Compatible with Existing 2.5 V/3.3 V LVEP, EP, LEVEL
and SG Devices
- V_{BB} Reference Voltage Output
- These are Pb-Free Devices



ON Semiconductor®

<http://onsemi.com>



1

QFN-16
MN SUFFIX
CASE 485G

MARKING DIAGRAM*

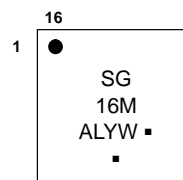

- A = Assembly Location
- L = Wafer Lot
- Y = Year
- W = Work Week
- = Pb-Free Package

(Note: Microdot may be in either location)

*For additional marking information, refer to Application Note AND8002/D.

ORDERING INFORMATION

See detailed ordering and shipping information in the package dimensions section on page 11 of this data sheet.

NBSG16M

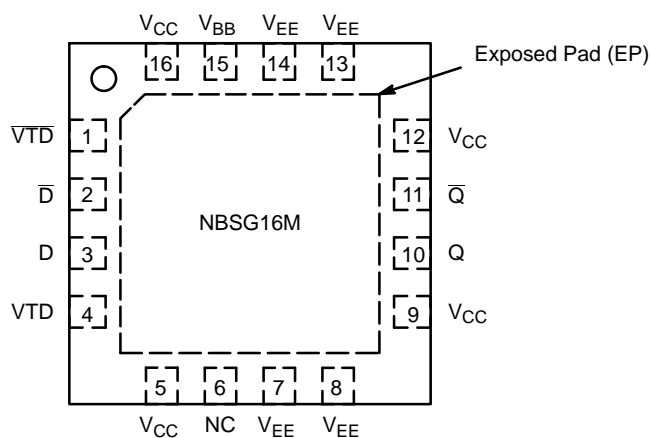

Figure 1. QFN-16 Pinout (Top View)

Table 1. PIN DESCRIPTION

Pin	Name	I/O	Description
1	\bar{V}_{TD}	-	Internal 50 Ω Termination Pin. See Table 2. (Note 2)
2	\bar{D}	LVDS, CML, ECL, LVTTTL, LVC MOS Input	Inverted Differential Input (Note 2)
3	D	LVDS, CML, ECL, LVTTTL, LVC MOS Input	Noninverted Differential Input. (Note 2)
4	V _{TD}	-	Internal 50 Ω Termination Pin. See Table 2. (Note 2)
5	V _{CC}	-	Positive Supply Voltage. All V _{CC} pins must be externally connected to Power Supply to guarantee proper operation.
6	NC	-	No Connect
7	V _{EE}	-	Negative Supply Voltage. All V _{EE} pins must be externally connected to Power Supply to guarantee proper operation.
8	V _{EE}	-	Negative Supply Voltage. All V _{EE} pins must be externally connected to Power Supply to guarantee proper operation.
9	V _{CC}	-	Positive Supply Voltage. All V _{CC} pins must be externally connected to Power Supply to guarantee proper operation.
10	Q	CML Output	Noninverted CML Differential Output with Internal 50 Ω Source Termination Resistor. (Note 1)
11	\bar{Q}	CML Output	Inverted CML Differential Output with Internal 50 Ω Source Termination Resistor. (Note 1)
12	V _{CC}	-	Positive Supply Voltage. All V _{CC} pins must be externally connected to Power Supply to guarantee proper operation.
13	V _{EE}	-	Negative Supply Voltage. All V _{EE} pins must be externally connected to Power Supply to guarantee proper operation.
14	V _{EE}	-	Negative Supply Voltage. All V _{EE} pins must be externally connected to Power Supply to guarantee proper operation.
15	V _{BB}	-	Internally Generated ECL Reference Output Voltage
16	V _{CC}	-	Positive Supply Voltage. All V _{CC} pins must be externally connected to Power Supply to guarantee proper operation.
-	EP	-	The Exposed Pad (EP) on the QFN-16 package bottom is thermally connected to the die for improved heat transfer out of package. The exposed pad must be attached to a heat-sinking conduit. The pad is not electrically connected to the die but may be electrically and thermally connected to V _{EE} on the PC board.

1. CML outputs require 50 Ω receiver termination resistor to V_{CC} for proper operation.
2. In the differential configuration when the input termination pin (V_{TD}, \bar{V}_{TD}) are connected to a common termination voltage, and if no signal is applied then the device will be susceptible to self-oscillation.

NBSG16M

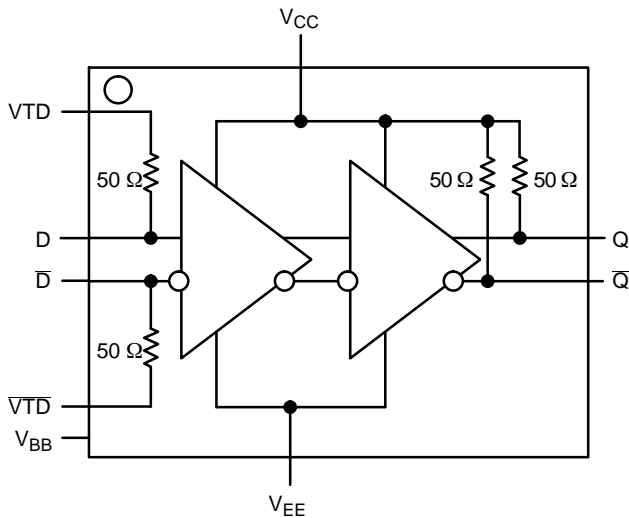

Figure 2. Logic Diagram

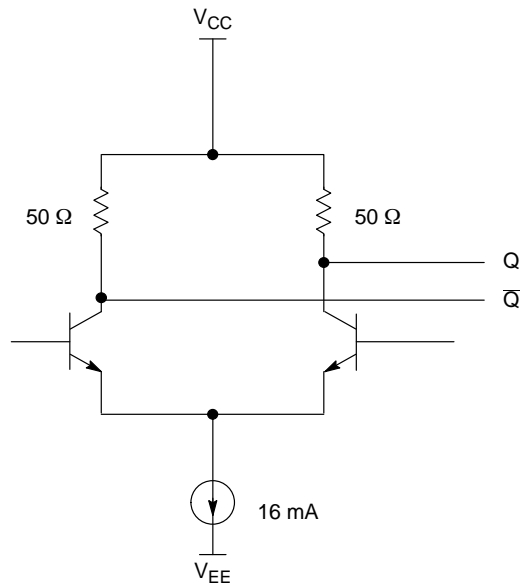

Figure 3. CML Output Structure

Table 2. Interfacing Options

INTERFACING OPTIONS	CONNECTIONS
CML	Connect VTD and \overline{VTD} to V_{CC}
LVDS	Connect VTD and \overline{VTD} together
AC-COUPLED	Bias VTD and \overline{VTD} Inputs within (V_{IHCMR}) Common Mode Range
RSECL, PECL, NECL	Standard ECL Termination Techniques
LVTTTL, LVCMOS	An external voltage should be applied to the unused complementary differential input. Nominal voltage 1.5 V for LVTTTL and $V_{CC}/2$ for LVCMOS inputs.

Table 3. ATTRIBUTES

Characteristics	Value
ESD Protection	Human Body Model Machine Model Charged Device Model
Moisture Sensitivity, Indefinite Time Out of Drypack (Note 3)	Level 1
Flammability Rating	Oxygen Index: 28 to 34 UL 94 V-0 @ 0.125 in
Transistor Count	145
Meets or exceeds JEDEC Spec EIA/JESD78 IC Latchup Test	

3. For additional Moisture Sensitivity information, refer to Application Note AND8003/D.

NBSG16M

Table 4. MAXIMUM RATINGS

Symbol	Parameter	Condition 1	Condition 2	Rating	Unit
V_{CC}	Positive Power Supply	$V_{EE} = 0\text{ V}$		3.6	V
V_{EE}	Negative Power Supply	$V_{CC} = 0\text{ V}$		-3.6	V
V_I	Positive Input Negative Input	$V_{EE} = 0\text{ V}$ $V_{CC} = 0\text{ V}$	$V_I \leq V_{CC}$ $V_I \geq V_{EE}$	3.6 -3.6	V
V_{INPP}	Differential Input Voltage $ D - \bar{D} $	$V_{CC} - V_{EE} \geq 2.8\text{ V}$ $V_{CC} - V_{EE} < 2.8\text{ V}$		2.8 $ V_{CC} - V_{EE} $	V
I_{IN}	Input Current Through R_T (50 Ω Resistor)	Static Surge		45 80	mA
I_{out}	Output Current	Continuous Surge		25 50	mA
I_{BB}	V_{BB} Sink/Source			1.0	mA
T_A	Operating Temperature Range			-40 to +85	$^{\circ}\text{C}$
T_{stg}	Storage Temperature Range			-65 to +150	$^{\circ}\text{C}$
θ_{JA}	Thermal Resistance (Junction-to-Ambient) (Note 4)	0 lfpm 500 lfpm		42 35	$^{\circ}\text{C}/\text{W}$
θ_{JC}	Thermal Resistance (Junction-to-Case)	1S2P (Note 4)		4.0	$^{\circ}\text{C}/\text{W}$
T_{sol}	Wave Solder Pb-Free	<2 to 3 sec @ 260 $^{\circ}\text{C}$		265	$^{\circ}\text{C}$

Stresses exceeding those listed in the Maximum Ratings table may damage the device. If any of these limits are exceeded, device functionality should not be assumed, damage may occur and reliability may be affected.

4. JEDEC standard multilayer board – 1S2P (1 signal, 2 power)

NBSG16M

Table 5. DC CHARACTERISTICS, POSITIVE CML OUTPUT

($V_{CC} = 2.5\text{ V}$; $V_{EE} = 0\text{ V}$) (Note 5)

Symbol	Characteristic	-40°C			25°C			85°C			Unit
		Min	Typ	Max	Min	Typ	Max	Min	Typ	Max	

POWER SUPPLY CURRENT

I_{CC}	Positive Power Supply Current	37	43	51	37	43	51	37	43	51	mA
----------	-------------------------------	----	----	----	----	----	----	----	----	----	----

CML OUTPUTS (Note 6)

V_{OH}	Output HIGH Voltage	$V_{CC} - 40$	$V_{CC} - 10$	V_{CC}	$V_{CC} - 40$	$V_{CC} - 10$	V_{CC}	$V_{CC} - 40$	$V_{CC} - 10$	V_{CC}	mV
V_{OL}	Output LOW Voltage		$V_{CC} - 400$	$V_{CC} - 330$		$V_{CC} - 400$	$V_{CC} - 330$		$V_{CC} - 400$	$V_{CC} - 330$	mV

DIFFERENTIAL CLOCK INPUTS DRIVEN SINGLE-ENDED (Figures 8 & 10) (Note 7)

V_{IH}	Input HIGH Voltage	1200		V_{CC}	1200		V_{CC}	1200		V_{CC}	mV
V_{IL}	Input LOW Voltage	0		$V_{IH} - 150$	0		$V_{IH} - 150$	0		$V_{IH} - 150$	mV
V_{th}	Input Threshold Voltage Range (Note 8)	950		$V_{CC} - 75$	950		$V_{CC} - 75$	950		$V_{CC} - 75$	mV
V_{ISE}	Single-Ended Input Voltage ($V_{IH} - V_{IL}$)	150		2600	150		2600	150		260	mV
V_{BB}	ECL Reference Output Voltage	1075	1170	1265	1075	1170	1265	1075	1170	1265	mV

DIFFERENTIAL INPUTS DRIVEN DIFFERENTIALLY (Figures 9 & 11) (Note 9)

V_{IHD}	Differential Input HIGH Voltage	1200		V_{CC}	1200		V_{CC}	1200		V_{CC}	mV
V_{ILD}	Differential Input LOW Voltage	0		$V_{IHD} - 75$	0		$V_{IHD} - 75$	0		$V_{IHD} - 75$	mV
V_{ID}	Differential Input Voltage ($V_{IHD} - V_{ILD}$)	75		2600	75		2600	75		2600	mV
V_{IHCMR}	Input HIGH Voltage Common Mode Range (Note 10) (Figure 12)	1200		2500	1200		2500	1200		2500	mV
I_{IH}	Input HIGH Current (@ V_{IH})		60	100		60	100		60	100	μA
I_{IL}	Input LOW Current (@ V_{IL})		25	50		25	50		25	50	μA

TERMINATION RESISTORS

R_{TIN}	Internal Input Termination Resistor	45	50	55	45	50	55	45	50	55	Ω
R_{TOUT}	Internal Output Termination Resistor	45	50	55	45	50	55	45	50	55	Ω

Product parametric performance is indicated in the Electrical Characteristics for the listed test conditions, unless otherwise noted. Product performance may not be indicated by the Electrical Characteristics if operated under different conditions.

NOTE: Device will meet the specifications after thermal equilibrium has been established when mounted in a test socket or printed circuit board with maintained transverse airflow greater than 500 lfm. Electrical parameters are guaranteed only over the declared operating temperature range. Functional operation of the device exceeding these conditions is not implied. Device specification limit values are applied individually under normal operating conditions and not valid simultaneously.

5. Input and output parameters vary 1:1 with V_{CC} .

6. All loading with 50 Ω to $V_{CC} - 2.0\text{ V}$.

7. V_{th} , V_{IH} , V_{IL} , and V_{ISE} parameters must be complied with simultaneously.

8. V_{th} is applied to the complementary input when operating in single-ended mode. $V_{th} = (V_{IH} - V_{IL}) / 2$.

9. V_{IHD} , V_{ILD} , V_{ID} and V_{IHCMR} parameters must be complied with simultaneously.

10. V_{IHCMR} min varies 1:1 with V_{EE} , V_{IHCMR} max varies 1:1 with V_{CC} . The V_{IHCMR} range is referenced to the most positive side of the differential input signal.

NBSG16M

Table 6. DC CHARACTERISTICS, POSITIVE CML OUTPUT

($V_{CC} = 3.3\text{ V}$; $V_{EE} = 0\text{ V}$) (Note 11)

Symbol	Characteristic	-40°C			25°C			85°C			Unit
		Min	Typ	Max	Min	Typ	Max	Min	Typ	Max	

POWER SUPPLY CURRENT

I_{CC}	Positive Power Supply Current	37	43	51	37	43	51	37	43	51	mA
----------	-------------------------------	----	----	----	----	----	----	----	----	----	----

CML OUTPUTS (Note 12)

V_{OH}	Output HIGH Voltage	$V_{CC} - 40$	$V_{CC} - 10$	V_{CC}	$V_{CC} - 40$	$V_{CC} - 10$	V_{CC}	$V_{CC} - 40$	$V_{CC} - 10$	V_{CC}	mV
V_{OL}	Output LOW Voltage		$V_{CC} - 400$	$V_{CC} - 330$		$V_{CC} - 400$	$V_{CC} - 330$		$V_{CC} - 400$	$V_{CC} - 330$	mV

DIFFERENTIAL CLOCK INPUTS DRIVEN SINGLE-ENDED (Figures 8 & 10) (Note 13)

V_{IH}	Input HIGH Voltage	1200		V_{CC}	1200		V_{CC}	1200		V_{CC}	mV
V_{IL}	Input LOW Voltage	0		$V_{IH} - 150$	0		$V_{IH} - 150$	0		$V_{IH} - 150$	mV
V_{th}	Input Threshold Voltage Range (Note 14)	950		$V_{CC} - 75$	950		$V_{CC} - 75$	950		$V_{CC} - 75$	mV
V_{ISE}	Single-Ended Input Voltage ($V_{IH} - V_{IL}$)	150		2600	150		2600	150		260	mV
V_{BB}	ECL Reference Voltage Output	1875	1970	2065	1875	1970	2065	1875	1970	2065	mV

DIFFERENTIAL INPUTS DRIVEN DIFFERENTIALLY (Figures 9 & 11) (Note 15)

V_{IHD}	Differential Input HIGH Voltage	1200		V_{CC}	1200		V_{CC}	1200		V_{CC}	mV
V_{ILD}	Differential Input LOW Voltage	0		$V_{IHD} - 75$	0		$V_{IHD} - 75$	0		$V_{IHD} - 75$	mV
V_{ID}	Differential Input Voltage ($V_{IHD} - V_{ILD}$)	75		2600	75		2600	75		2600	mV
V_{IHCMR}	Input HIGH Voltage Common Mode Range (Note 16) (Figure 12)	1200		3300	1200		3300	1200		3300	mV
I_{IH}	Input HIGH Current (@ V_{IH})		60	100		60	100		60	100	μA
I_{IL}	Input LOW Current (@ V_{IL})		25	50		25	50		25	50	μA

TERMINATION RESISTORS

R_{TIN}	Internal Input Termination Resistor	45	50	55	45	50	55	45	50	55	Ω
R_{TOUT}	Internal Output Termination Resistor	45	50	55	45	50	55	45	50	55	Ω

Product parametric performance is indicated in the Electrical Characteristics for the listed test conditions, unless otherwise noted. Product performance may not be indicated by the Electrical Characteristics if operated under different conditions.

NOTE: Device will meet the specifications after thermal equilibrium has been established when mounted in a test socket or printed circuit board with maintained transverse airflow greater than 500 lfm. Electrical parameters are guaranteed only over the declared operating temperature range. Functional operation of the device exceeding these conditions is not implied. Device specification limit values are applied individually under normal operating conditions and not valid simultaneously.

11. Input and output parameters vary 1:1 with V_{CC} .

12. All loading with 50 Ω to $V_{CC} - 2.0\text{ V}$.

13. V_{th} , V_{IH} , V_{IL} , and V_{ISE} parameters must be complied with simultaneously.

14. V_{th} is applied to the complementary input when operating in single-ended mode. $V_{th} = (V_{IH} - V_{IL}) / 2$.

15. V_{IHD} , V_{ILD} , V_{ID} and V_{IHCMR} parameters must be complied with simultaneously.

16. V_{IHCMR} min varies 1:1 with V_{EE} , V_{IHCMR} max varies 1:1 with V_{CC} . The V_{IHCMR} range is referenced to the most positive side of the differential input signal.

NBSG16M

Table 7. DC CHARACTERISTICS, NEGATIVE CML OUTPUT

($V_{CC} = 0$ V; $V_{EE} = -3.465$ V to -2.375 V) (Note 17)

Symbol	Characteristic	-40°C			25°C			85°C			Unit
		Min	Typ	Max	Min	Typ	Max	Min	Typ	Max	

POWER SUPPLY CURRENT

I_{CC}	Positive Power Supply Current	37	43	51	37	43	51	37	43	51	mA
----------	-------------------------------	----	----	----	----	----	----	----	----	----	----

CML OUTPUTS (Note 18)

V_{OH}	Output HIGH Voltage	$V_{CC} - 40$	$V_{CC} - 10$	V_{CC}	$V_{CC} - 40$	$V_{CC} - 10$	V_{CC}	$V_{CC} - 40$	$V_{CC} - 10$	V_{CC}	mV
V_{OL}	Output LOW Voltage		$V_{CC} - 400$	$V_{CC} - 330$		$V_{CC} - 400$	$V_{CC} - 330$		$V_{CC} - 400$	$V_{CC} - 330$	mV

DIFFERENTIAL CLOCK INPUTS DRIVEN SINGLE-ENDED (Figures 8 & 10) (Note 19)

V_{IH}	Input HIGH Voltage	$V_{EE} + 1200$		V_{CC}	$V_{EE} + 1200$		V_{CC}	$V_{EE} + 1200$		V_{CC}	mV
V_{IL}	Input LOW Voltage	V_{EE}		$V_{IH} - 150$	V_{EE}		$V_{IH} - 150$	V_{EE}		$V_{IH} - 150$	mV
V_{th}	Input Threshold Voltage Range (Note 20)	$V_{EE} + 950$		$V_{CC} - 75$	$V_{EE} + 950$		$V_{CC} - 75$	$V_{EE} + 950$		$V_{CC} - 75$	mV
V_{ISE}	Single-Ended Input Voltage ($V_{IH} - V_{IL}$)	150		2600	150		2600	150		260	mV
V_{BB}	ECL Reference Voltage Output	-1425	-1330	-1235	-1425	-1330	-1235	-1425	-1330	-1235	mV

DIFFERENTIAL INPUTS DRIVEN DIFFERENTIALLY (Figures 9 & 11) (Note 21)

V_{IHD}	Differential Input HIGH Voltage	$V_{EE} + 1200$		V_{CC}	$V_{EE} + 1200$		V_{CC}	$V_{EE} + 1200$		V_{CC}	mV
V_{ILD}	Differential Input LOW Voltage	V_{EE}		$V_{IHD} - 75$	V_{EE}		$V_{IHD} - 75$	V_{EE}		$V_{IHD} - 75$	mV
V_{ID}	Differential Input Voltage ($V_{IHD} - V_{ILD}$)	75		2600	75		2600	75		2600	mV
V_{IHCMR}	Input HIGH Voltage Common Mode Range (Note 22) (Figure 12)	$V_{EE} + 1200$		V_{CC}	$V_{EE} + 1200$		V_{CC}	$V_{EE} + 1200$		V_{CC}	mV
I_{IH}	Input HIGH Current (@ V_{IH})		60	100		60	100		60	100	μ A
I_{IL}	Input LOW Current (@ V_{IL})		25	50		25	50		25	50	μ A

TERMINATION RESISTORS

R_{TIN}	Internal Input Termination Resistor	45	50	55	45	50	55	45	50	55	Ω
R_{TOUT}	Internal Output Termination Resistor	45	50	55	45	50	55	45	50	55	Ω

Product parametric performance is indicated in the Electrical Characteristics for the listed test conditions, unless otherwise noted. Product performance may not be indicated by the Electrical Characteristics if operated under different conditions.

NOTE: Device will meet the specifications after thermal equilibrium has been established when mounted in a test socket or printed circuit board with maintained transverse airflow greater than 500 lpm. Electrical parameters are guaranteed only over the declared operating temperature range. Functional operation of the device exceeding these conditions is not implied. Device specification limit values are applied individually under normal operating conditions and not valid simultaneously.

17. Input and output parameters vary 1:1 with V_{CC} .

18. All loading with 50Ω to $V_{CC} - 2.0$ V.

19. V_{th} , V_{IH} , V_{IL} , and V_{ISE} parameters must be complied with simultaneously.

20. V_{th} is applied to the complementary input when operating in single-ended mode. $V_{th} = (V_{IH} - V_{IL}) / 2$.

21. V_{IHD} , V_{ILD} , V_{ID} and V_{IHCMR} parameters must be complied with simultaneously.

22. V_{IHCMR} min varies 1:1 with V_{EE} , V_{IHCMR} max varies 1:1 with V_{CC} . The V_{IHCMR} range is referenced to the most positive side of the differential input signal.

NBSG16M

Table 8. AC CHARACTERISTICS

($V_{CC} = 0\text{ V}$; $V_{EE} = -3.465\text{ V}$ to -2.375 V or $V_{CC} = 2.375\text{ V}$ to 3.465 V ; $V_{EE} = 0\text{ V}$)

Symbol	Characteristic	-40°C			25°C			85°C			Unit
		Min	Typ	Max	Min	Typ	Max	Min	Typ	Max	
V_{OUTPP}	Output Voltage Amplitude (See Figure 4) (Note 23) $f_{in} < 7\text{ GHz}$ $f_{in} < 10\text{ GHz}$	300 200	400 250		300 200	400 250		300 100	400 150		mV
t_{PLH} , t_{PHL}	Propagation Delay to Output Differential	90	110	150	100	120	150	100	125	155	ps
t_{SKEW}	Duty Cycle Skew (Note 24)		3	15		3	15		3	15	ps
t_{JITTER}	RMS Random Clock Jitter (Note 26) $f_{in} < 10\text{ GHz}$ Peak-to-Peak Data Dependent Jitter (Note 27) $f_{in} < 10\text{ Gb/s}$		0.2 8	1 15		0.2 8	1 15		0.2 8	1.0 15	ps
V_{INPP}	Input Voltage Swing/Sensitivity (Differential Configuration) (Note 25)	75		2500	75		2500	75		2500	mV
t_r t_f	Output Rise/Fall Times @ 1 GHz (20% – 80%) Q, \bar{Q}	21	35	53	21	35	53	21	35	53	ps

NOTE: Device will meet the specifications after thermal equilibrium has been established when mounted in a test socket or printed circuit board with maintained transverse airflow greater than 500 lfm. Electrical parameters are guaranteed only over the declared operating temperature range. Functional operation of the device exceeding these conditions is not implied. Device specification limit values are applied individually under normal operating conditions and not valid simultaneously.

23. Measured using a 400 mV source, 50% duty cycle clock source. All loading with $50\ \Omega$ to V_{CC} . Input edge rates 40 ps (20% – 80%).

24. See Figure 13 $t_{skew} = |t_{PLH} - t_{PHL}|$ for a nominal 50% differential clock input waveform.

25. $V_{INPP(max)}$ cannot exceed $V_{CC} - V_{EE}$. (Applicable only when $V_{CC} - V_{EE} < 2500\text{ mV}$). Input voltage swing is a single-ended measurement operating in differential mode.

26. Additive RMS jitter with 50% duty cycle clock signal at 10GHz.

27. Additive Peak-to-Peak data dependent jitter with NRZ PRBS³¹-1 data rate at 10 Gb/s.

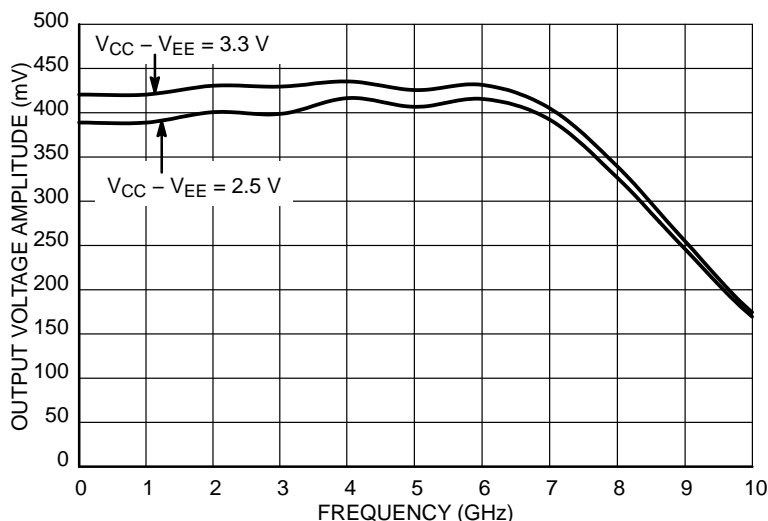

Figure 4. Output Voltage Amplitude (V_{OUTPP}) versus Input Clock Frequency (f_{in}) at Ambient Temperature (Typical)

NBSG16M

Application Information

All inputs can accept PECL, CML, and LVDS signal levels. The input voltage can range from V_{CC} to 1.2 V.

Examples interfaces are illustrated below in a 50 Ω environment ($Z = 50 \Omega$).

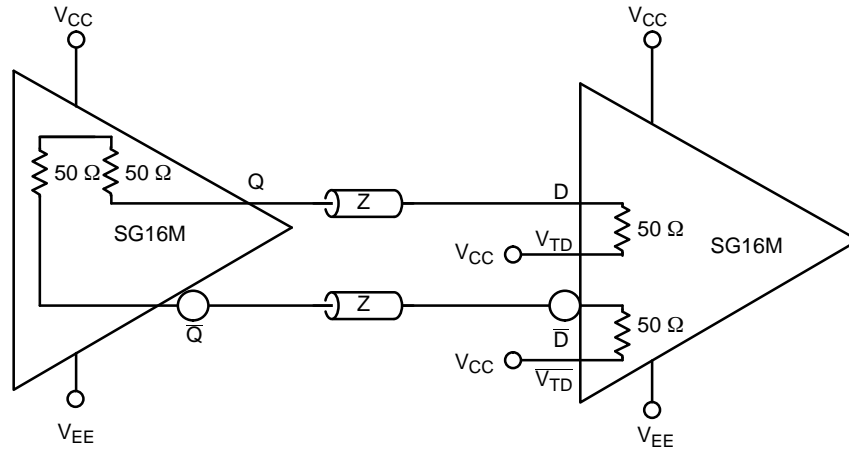

Figure 5. CML to CML Interface

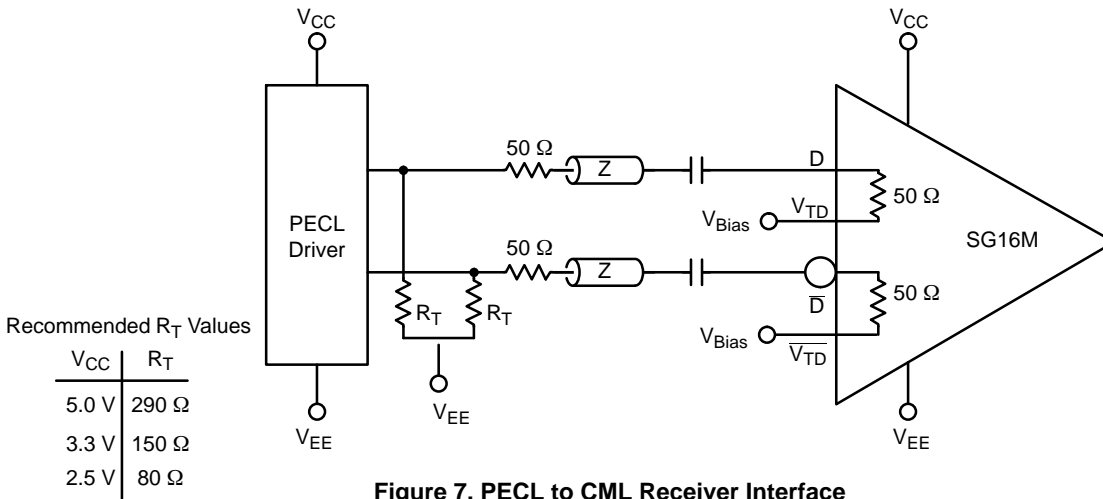

Figure 7. PECL to CML Receiver Interface

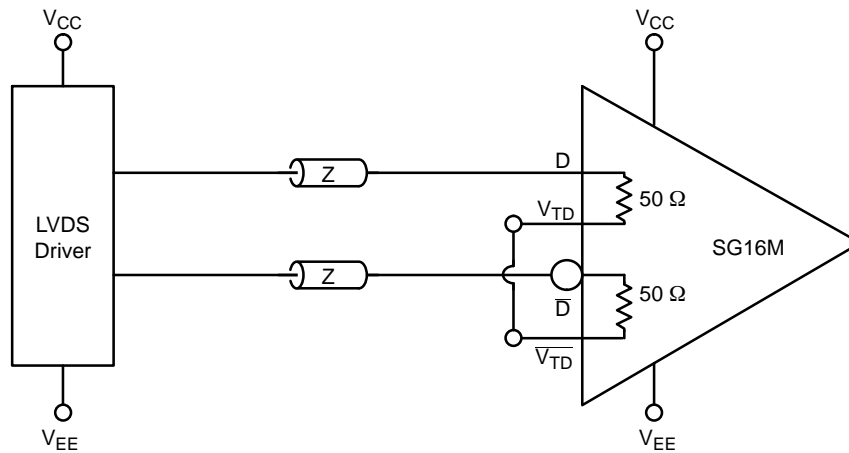

Figure 6. LVDS to CML Receiver Interface

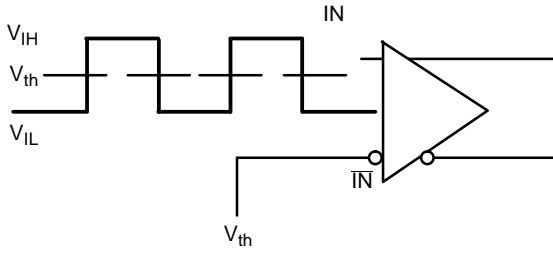

Figure 8. Differential Input Driven Single-Ended

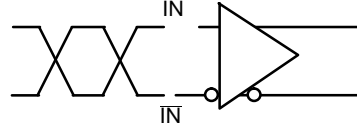

Figure 9. Differential Inputs Driven Differentially

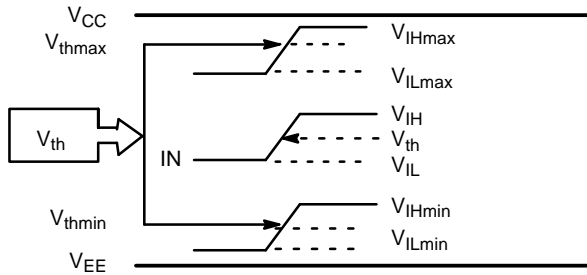

Figure 10. V_{th} Diagram

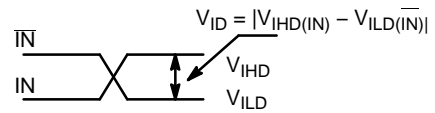

Figure 11. Differential Inputs Driven Differentially

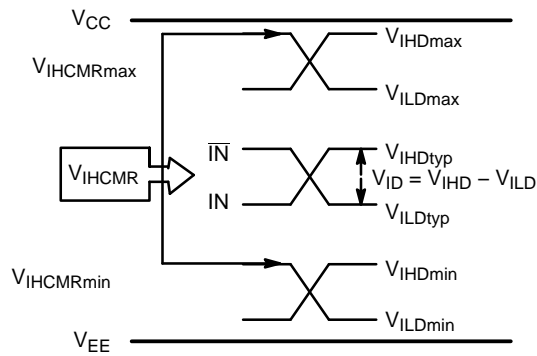

Figure 12. V_{IHCMR} Diagram

NBSG16M

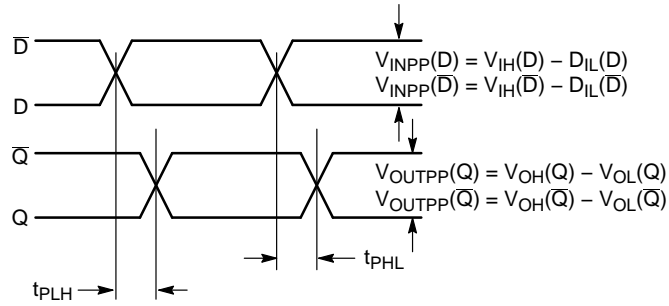
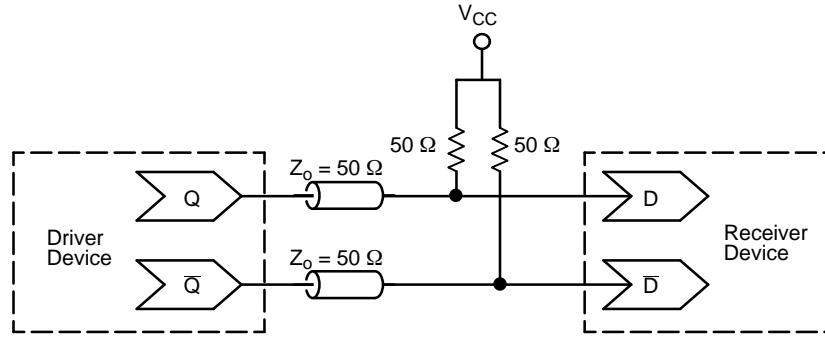

Figure 13. AC Reference Measurement



**Figure 14. Typical Termination for Output Driver and Device Evaluation
(Refer to Application Note AND8020 – Termination of ECL Logic Devices)**

ORDERING INFORMATION

Device	Package	Shipping†
NBSG16MMNG	QFN-16 (Pb-Free / Halide-Free)	123 Units / Tube
NBSG16MMNR2G	QFN-16 (Pb-Free / Halide-Free)	3000 / Tape & Reel

†For information on tape and reel specifications, including part orientation and tape sizes, please refer to our Tape and Reel Packaging Specifications Brochure, BRD8011/D.

NBSG16M

PACKAGE DIMENSIONS

QFN16 3x3, 0.5P
CASE 485G
ISSUE F

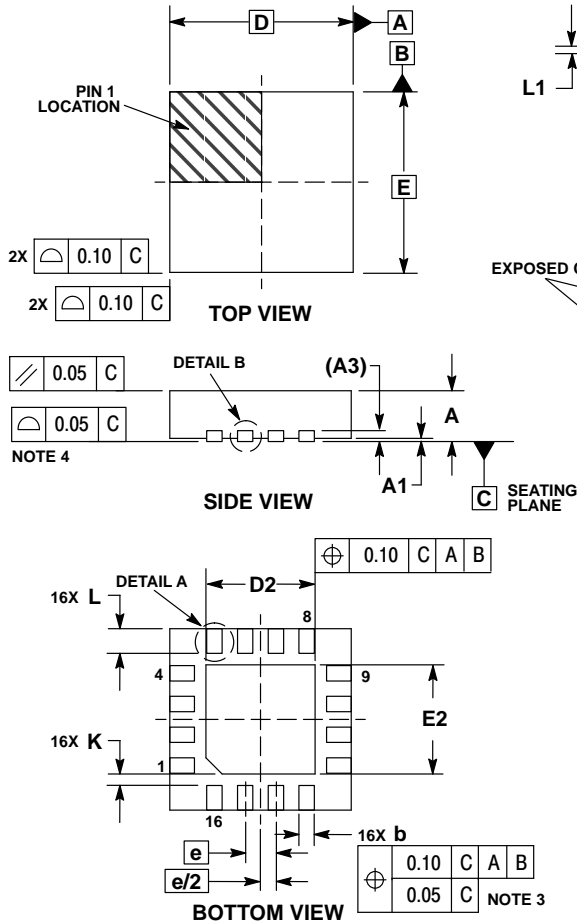

NOTES:

1. DIMENSIONING AND TOLERANCING PER ASME Y14.5M, 1994.
2. CONTROLLING DIMENSION: MILLIMETERS.
3. DIMENSION b APPLIES TO PLATED TERMINAL AND IS MEASURED BETWEEN 0.25 AND 0.30 MM FROM TERMINAL.
4. COPLANARITY APPLIES TO THE EXPOSED PAD AS WELL AS THE TERMINALS.

DIM	MILLIMETERS		
	MIN	NOM	MAX
A	0.80	0.90	1.00
A1	0.00	0.03	0.05
A3	0.20 REF		
b	0.18	0.24	0.30
D	3.00 BSC		
D2	1.65	1.75	1.85
E	3.00 BSC		
E2	1.65	1.75	1.85
e	0.50 BSC		
K	0.18 TYP		
L	0.30	0.40	0.50
L1	0.00	0.08	0.15

*For additional information on our Pb-Free strategy and soldering details, please download the ON Semiconductor Soldering and Mounting Techniques Reference Manual, SOLDERM/D.

The products described herein (NBSG16M), may be covered by U.S. patents including 6,362,644. There may be other patents pending.

ON Semiconductor and are registered trademarks of Semiconductor Components Industries, LLC (SCILLC). SCILLC owns the rights to a number of patents, trademarks, copyrights, trade secrets, and other intellectual property. A listing of SCILLC's product/patent coverage may be accessed at www.onsemi.com/site/pdf/Patent-Marketing.pdf. SCILLC reserves the right to make changes without further notice to any products herein. SCILLC makes no warranty, representation or guarantee regarding the suitability of its products for any particular purpose, nor does SCILLC assume any liability arising out of the application or use of any product or circuit, and specifically disclaims any and all liability, including without limitation special, consequential or incidental damages. "Typical" parameters which may be provided in SCILLC data sheets and/or specifications can and do vary in different applications and actual performance may vary over time. All operating parameters, including "Typicals" must be validated for each customer application by customer's technical experts. SCILLC does not convey any license under its patent rights nor the rights of others. SCILLC products are not designed, intended, or authorized for use as components in systems intended for surgical implant into the body, or other applications intended to support or sustain life, or for any other application in which the failure of the SCILLC product could create a situation where personal injury or death may occur. Should Buyer purchase or use SCILLC products for any such unintended or unauthorized application, Buyer shall indemnify and hold SCILLC and its officers, employees, subsidiaries, affiliates, and distributors harmless against all claims, costs, damages, and expenses, and reasonable attorney fees arising out of, directly or indirectly, any claim of personal injury or death associated with such unintended or unauthorized use, even if such claim alleges that SCILLC was negligent regarding the design or manufacture of the part. SCILLC is an Equal Opportunity/Affirmative Action Employer. This literature is subject to all applicable copyright laws and is not for resale in any manner.

PUBLICATION ORDERING INFORMATION

LITERATURE FULFILLMENT:
Literature Distribution Center for ON Semiconductor
P.O. Box 5163, Denver, Colorado 80217 USA
Phone: 303-675-2175 or 800-344-3860 Toll Free USA/Canada
Fax: 303-675-2176 or 800-344-3867 Toll Free USA/Canada
Email: orderlit@onsemi.com

N. American Technical Support: 800-282-9855 Toll Free
USA/Canada
Europe, Middle East and Africa Technical Support:
Phone: 421 33 790 2910
Japan Customer Focus Center
Phone: 81-3-5817-1050

ON Semiconductor Website: www.onsemi.com
Order Literature: <http://www.onsemi.com/orderlit>
For additional information, please contact your local Sales Representative

X-ON Electronics

Largest Supplier of Electrical and Electronic Components

Click to view similar products for [Buffers & Line Drivers](#) category:

Click to view products by [ON Semiconductor](#) manufacturer:

Other Similar products are found below :

[LXV200-024SW](#) [74AUP2G34FW3-7](#) [HEF4043BP](#) [PI74FCT3244L](#) [MC74HCT365ADTR2G](#) [Le87401NQC](#) [Le87402MQC](#) [028192B](#)
[042140C](#) [051117G](#) [070519XB](#) [NL17SZ07P5T5G](#) [NLU1GT126AMUTCG](#) [74AUP1G17FW5-7](#) [74LVC2G17FW4-7](#) [CD4502BE](#) [5962-](#)
[8982101PA](#) [5962-9052201PA](#) [74LVC1G125FW4-7](#) [NL17SH17P5T5G](#) [NL17SH125P5T5G](#) [NLV37WZ07USG](#) [RHRXH162244K1](#)
[74AUP1G34FW5-7](#) [74AUP1G07FW5-7](#) [74LVC2G126RA3-7](#) [NLX2G17CMUTCG](#) [74LVCE1G125FZ4-7](#) [Le87501NQC](#) [74AUP1G126FW5-](#)
[7](#) [TC74HC4050AP\(F\)](#) [74LVCE1G07FZ4-7](#) [NLX3G16DMUTCG](#) [NLX2G06AMUTCG](#) [NLVVHC1G50DFT2G](#) [NLU2G17AMUTCG](#)
[LE87100NQC](#) [LE87290YQC](#) [LE87290YQCT](#) [LE87511NQC](#) [LE87511NQCT](#) [LE87557NQC](#) [LE87557NQCT](#) [LE87614MQC](#)
[LE87614MQCT](#) [74AUP1G125FW5-7](#) [NLU2G16CMUTCG](#) [MC74LCX244MN2TWG](#) [NLV74VHC125DTR2G](#) [NL17SG126DFT2G](#)