

ON Semiconductor

Is Now

onsemi™

To learn more about onsemi™, please visit our website at
www.onsemi.com

onsemi and **onsemi** and other names, marks, and brands are registered and/or common law trademarks of Semiconductor Components Industries, LLC dba "**onsemi**" or its affiliates and/or subsidiaries in the United States and/or other countries. **onsemi** owns the rights to a number of patents, trademarks, copyrights, trade secrets, and other intellectual property. A listing of **onsemi** product/patent coverage may be accessed at www.onsemi.com/site/pdf/Patent-Marking.pdf. **onsemi** reserves the right to make changes at any time to any products or information herein, without notice. The information herein is provided "as-is" and **onsemi** makes no warranty, representation or guarantee regarding the accuracy of the information, product features, availability, functionality, or suitability of its products for any particular purpose, nor does **onsemi** assume any liability arising out of the application or use of any product or circuit, and specifically disclaims any and all liability, including without limitation special, consequential or incidental damages. Buyer is responsible for its products and applications using **onsemi** products, including compliance with all laws, regulations and safety requirements or standards, regardless of any support or applications information provided by **onsemi**. "Typical" parameters which may be provided in **onsemi** data sheets and/or specifications can and do vary in different applications and actual performance may vary over time. All operating parameters, including "Typicals" must be validated for each customer application by customer's technical experts. **onsemi** does not convey any license under any of its intellectual property rights nor the rights of others. **onsemi** products are not designed, intended, or authorized for use as a critical component in life support systems or any FDA Class 3 medical devices or medical devices with a same or similar classification in a foreign jurisdiction or any devices intended for implantation in the human body. Should Buyer purchase or use **onsemi** products for any such unintended or unauthorized application, Buyer shall indemnify and hold **onsemi** and its officers, employees, subsidiaries, affiliates, and distributors harmless against all claims, costs, damages, and expenses, and reasonable attorney fees arising out of, directly or indirectly, any claim of personal injury or death associated with such unintended or unauthorized use, even if such claim alleges that **onsemi** was negligent regarding the design or manufacture of the part. **onsemi** is an Equal Opportunity/Affirmative Action Employer. This literature is subject to all applicable copyright laws and is not for resale in any manner. Other names and brands may be claimed as the property of others.



ON Semiconductor®

NC7SB3157, FSA3157 Low-Voltage SPDT Analog Switch or 2:1 Multiplexer / De-multiplexer Bus Switch

Features

- Useful in Both Analog and Digital Applications
- Space-Saving, SC70 6-Lead Surface Mount Package
- Ultra-Small, MicroPak™ Leadless Package
- Low On Resistance: <math><10\Omega</math> on Typical at 3.3V V_{CC}
- Broad V_{CC} Operating Range: 1.65V to 5.5V
- Rail-to-Rail Signal Handling
- Power-Down, High-Impedance Control Input
- Over-Voltage Tolerance of Control Input to 7.0V
- Break-Before-Make Enable Circuitry
- 250MHz, 3dB Bandwidth

Description

The NC7SB3157 / FSA3157 is a high-performance, single-pole / double-throw (SPDT) analog switch or 2:1 multiplexer / de-multiplexer bus switch.

The device is fabricated with advanced sub-micron CMOS technology to achieve high-speed enable and disable times and low on resistance. The break-before-make select circuitry prevents disruption of signals on the B Port due to both switches temporarily being enabled during select pin switching. The device is specified to operate over the 1.65 to 5.5V V_{CC} operating range. The control input tolerates voltages up to 5.5V, independent of the V_{CC} operating range.

Ordering Information

Part Number	Top Mark	 Eco Status	Package Description	Packing Method
NC7SB3157P6X	B7A	RoHS	6-Lead, SC70, EIAJ SC88, 1.25mm Wide Package	3000 Units on Tape and Reel
NC7SB3157L6X	BB	RoHS	6-Lead, MicroPak 1.0mm Wide Package	5000 Units on Tape and Reel
FSA3157P6X	B7A	RoHS	6-Lead, SC70, EIAJ SC88, 1.25mm Wide Package	3000 Units on Tape and Reel
FSA3157L6X	BB	RoHS	6-Lead, MicroPak 1.0mm Wide Package	5000 Units on Tape and Reel

NC7SB3157, FSA3157 — Low-Voltage SPDT Analog Switch or 2:1 Multiplexer / De-multiplexer Bus Switch

Logic Symbol

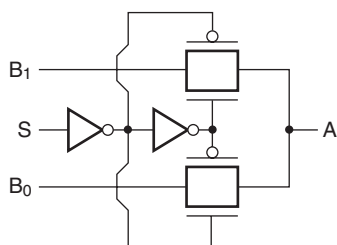
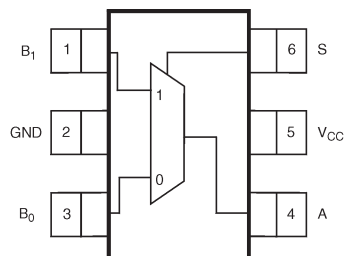

Figure 1. Logic Symbol

Connection Diagrams



2. Pin Assignments SC70

Analog Symbol

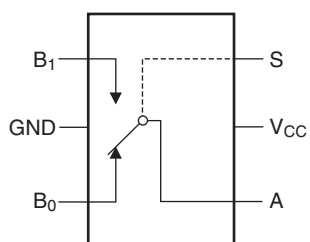

Figure 3. Analog Symbol

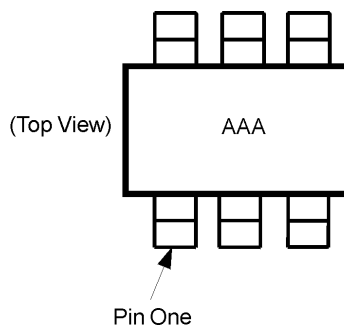

Figure 4. Pin One Orientation

Function Table

Input (S)	Function
Logic Level Low	B ₀ Connected to A
Logic Level High	B ₁ Connected to A

Note:

Orientation of top mark determines pin one location. Read the top product code mark left to right and pin one is the lower left pin (see Figure 4).

Pin Descriptions

Pin Names	Description
A, B ₀ , B ₁	Data Ports
S	Control Input

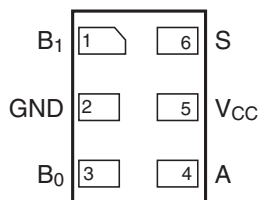

Figure 5. Pad Assignments for MicroPak™

Absolute Maximum Ratings

Stresses exceeding the absolute maximum ratings may damage the device. The device may not function or be operable above the recommended operating conditions and stressing the parts to these levels is not recommended. In addition, extended exposure to stresses above the recommended operating conditions may affect device reliability. The absolute maximum ratings are stress ratings only.

Symbol	Parameter	Min.	Max.	Unit
V_{CC}	Supply Voltage	-0.5	+7.0	V
V_S	DC Switch Voltage ⁽¹⁾	-0.5	$V_{CC} + 0.5$	V
V_{IN}	DC Input Voltage ⁽¹⁾	-0.5	+7.0	V
I_{IK}	DC Input Diode Current at $V_{IN} < 0V$		-50	mA
I_{OUT}	DC Output Current		128	mA
I_{CC}/I_{GND}	DC V_{CC} or Ground Current		± 100	mA
T_{STG}	Storage Temperature Range	-65	+150	°C
T_J	Junction Temperature Under Bias		+150	°C
T_L	Junction Lead Temperature (Soldering, 10 seconds)		+260	°C
MSL	Moisture Sensitivity Level (JEDEC J-STD-020A)		1	Level
P_D	Power Dissipation at +85°C		180	mW
ESD	Human Body Model, JESD22-A114		4000	V

Note:

- The input and output negative voltage ratings may be exceeded if the input and output diode current ratings are observed.

Recommended Operating Conditions

The Recommended Operating Conditions table defines the conditions for actual device operation. Recommended operating conditions are specified to ensure optimal performance to the datasheet specifications. ON Semiconductor does not recommend exceeding them or designing to absolute maximum ratings.

Symbol	Parameter	Min.	Max.	Unit	
V_{CC}	Supply Voltage Operating	1.65	5.50	V	
V_{IN}	Control Input Voltage ⁽²⁾	0	V_{CC}	V	
V_{IN}	Switch Input Voltage ⁽²⁾	0	V_{CC}	V	
V_{OUT}	Output Voltage ⁽²⁾	0	V_{CC}	V	
T_A	Operating Temperature	-40	+85	°C	
t_r, t_f	Input Rise and Fall Time	Control Input $V_{CC} = 2.3V-3.6V$	0	10	ns/V
		Control Input $V_{CC} = 4.5V-5.5V$	0	5	ns/V
θ_{JA}	Thermal Resistance, SC70		270	°C/W	

Note:

- Control input must be held HIGH or LOW; it must not float.

DC Electrical Characteristics

Symbol	Parameter	Conditions	V _{CC} (V)	T _A = +25°C			T _A = -40°C to +85°C		Units
				Min.	Typ.	Max.	Min.	Max.	
V _{IH}	High Level Input Voltage		1.65 – 1.95	0.75 V _{CC}			0.75 V _{CC}		V
			2.3 – 5.5	0.7 V _{CC}			0.7 V _{CC}		
V _{IL}	Low Level Input Voltage		1.65 – 1.95			0.25 V _{CC}		0.25 V _{CC}	V
			2.3 – 5.5			0.3 V _{CC}		0.3 V _{CC}	
I _{IN}	Input Leakage Current	0 ≤ V _{IN} ≤ 5.5V	0 – 5.5		±0.05	±0.1		±1	μA
I _{OFF}	Off State Leakage Current	0 ≤ A, B ≤ V _{CC}	1.65 – 5.5		±0.05	±0.1		±1	μA
R _{ON}	Switch On Resistance ⁽³⁾	V _{IN} = 0V, I _O = 30mA	4.5		3.0	7.0		7.0	Ω
		V _{IN} = 2.4V, I _O = -30mA			5.0	12.0		12.0	
		V _{IN} = 4.5V, I _O = -30mA		7.0	15.0		15.0		
		V _{IN} = 0V, I _O = 24mA	3.0		4.0	9.0		9.0	
		V _{IN} = 3V, I _O = -24mA			10.0	20.0		20.0	
		V _{IN} = 0V, I _O = 8mA	2.3		5.0	12.0		12.0	
		V _{IN} = 2.3V, I _O = -8mA			13.0	30.0		30.0	
		V _{IN} = 0V, I _O = 4mA	1.65		6.5	20.0		20.0	
V _{IN} = 1.65V, I _O = -4mA		17.0		50.0		50.0			
I _{CC}	Quiescent Supply Current; All Channels On or Off	V _{IN} = V _{CC} or GND I _{OUT} = 0	5.5			1		10	μA
	Analog Signal Range		V _{CC}	0		V _{CC}	0	V _{CC}	V
R _{RANGE}	On Resistance Over Signal Range ^(3, 7)	I _A = -30mA, 0 ≤ V _{Bn} ≤ V _{CC}	4.5					25.0	Ω
		I _A = -24mA, 0 ≤ V _{Bn} ≤ V _{CC}	3.0					50.0	
		I _A = -8mA, 0 ≤ V _{Bn} ≤ V _{CC}	2.3					100	
		I _A = -4mA, 0 ≤ V _{Bn} ≤ V _{CC}	1.65					300	
ΔR _{ON}	On Resistance Match Between-Channels ^(3, 4, 5)	I _A = -30mA, V _{Bn} = 3.15	4.5		0.15				Ω
		I _A = -24mA, V _{Bn} = 2.1	3.0		0.2				
		I _A = -8mA, V _{Bn} = 1.6	2.3		0.5				
		I _A = -4mA, V _{Bn} = 1.15	1.65		0.50				
R _{flat}	On Resistance Flatness ^(3, 4, 6)	I _A = -30mA, 0 ≤ V _{Bn} ≤ V _{CC}	5.0		6.0				Ω
		I _A = -24mA, 0 ≤ V _{Bn} ≤ V _{CC}	3.3		12.0				
		I _A = -8mA, 0 ≤ V _{Bn} ≤ V _{CC}	2.5		28.0				
		I _A = -4mA, 0 ≤ V _{Bn} ≤ V _{CC}	1.8		125				

Notes:

- Measured by the voltage drop between A and B pins at the indicated current through the switch. On resistance is determined by the lower of the voltages on the two (A or B Ports).
- Parameter is characterized, but not tested in production.
- ΔR_{ON} = R_{ON} max – R_{ON} minimum measured at identical V_{CC}, temperature, and voltage levels.
- Flatness is defined as the difference between the maximum and minimum value of on resistance over the specified range of conditions.
- Guaranteed by design.

AC Electrical Characteristics

Symbol	Parameter	Conditions	V _{CC} (V)	T _A = +25°C			T _A = -40°C to +85°C		Units	Figure Number
				Min.	Typ.	Max.	Min.	Max.		
t _{PHL} , t _{PLH}	Propagation Delay Bus-to-Bus ⁽⁸⁾	V _I = OPEN	1.65 – 1.95			3.5		3.5	ns	Figure 12 Figure 13
			2.3 – 2.7			1.2		1.2		
			3.0 – 3.6			0.8		0.8		
			4.5 – 5.5			0.3		0.3		
t _{PZL} , t _{PZH}	Output Enable Time Turn-On Time (A to B _n)	V _I = 2 x V _{CC} for t _{PZL} V _I = 0V for t _{PZH}	1.65 – 1.95	7.0		23.0	7.0	24.0	ns	Figure 12 Figure 13
			2.3 – 2.7	3.5		13.0	3.5	14.0		
			3.0 – 3.6	2.5		6.9	2.5	7.6		
			4.5 – 5.5	1.7		5.2	1.7	5.7		
t _{PLZ} , t _{PHZ}	Output Disable Time Turn-Off Time (A Port to B Port)	V _I = 2 x V _{CC} for t _{PLZ} V _I = 0V for t _{PHZ}	1.65 – 1.95	3.0		12.5	3.0	13.0	ns	Figure 12 Figure 13
			2.3 – 2.7	2.0		7.0	2.0	7.5		
			3.0 – 3.6	1.5		5.0	1.5	5.3		
			4.5 – 5.5	0.8		3.5	0.8	3.8		
t _{B-M}	Break-Before-Make Time ⁽⁹⁾		1.65 – 1.95	0.5			0.5		ns	Figure 14
			2.3 – 2.7	0.5			0.5			
			3.0 – 3.6	0.5			0.5			
			4.5 – 5.5	0.5			0.5			
Q	Charge Injection ⁽⁹⁾	C _L = 0.1nF, V _{GEN} = 0V,	5.0		7.0			pC	Figure 15	
		R _{GEN} = 0Ω	3.3		3.0					
OIRR	Off Isolation ⁽¹⁰⁾	R _L = 50Ω, f = 10MHz	1.65 – 5.5		-57.0			dB	Figure 16	
Xtalk	Crosstalk	R _L = 50Ω, f = 10MHz	1.65 – 5.5		-54.0			dB	Figure 17	
BW	-3dB Bandwidth	R _L = 50Ω	1.65 – 5.5		250			MHz	Figure 20	
THD	Total Harmonic Distortion ⁽⁹⁾	R _L = 600Ω, 0.5 V _{PP} , f = 600 Hz to 20 KHz	5.0		.011			%		

Notes:

8. This parameter is guaranteed by design but not tested. The bus switch contributes no propagation delay other than the RC delay of the on resistance of the switch and the 50pF load capacitance, when driven by an ideal voltage source (zero output impedance).
9. Guaranteed by design.
10. Off Isolation = 20 log₁₀ [V_A / V_{Bn}].

Capacitance

T_A = +25°C, f = 1MHz. Capacitance is characterized, but not tested in production.

Symbol	Parameter	Conditions	Typ.	Max.	Units	Figure Number
C _{IN}	Control Pin Input Capacitance	V _{CC} = 0V	2.3		pF	
C _{IO-B}	B Port Off Capacitance	V _{CC} = 5.0V	6.5		pF	Figure 18
C _{IOA-ON}	A Port Capacitance When Switch Is Enabled	V _{CC} = 5.0V	18.5		pF	Figure 19

Typical Characteristics

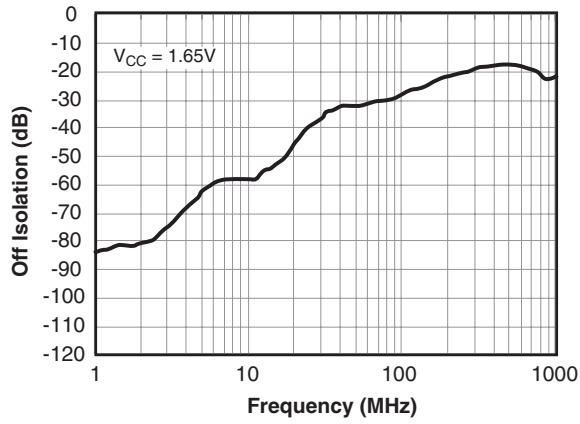

Figure 6. Off Isolation, $V_{CC} = 1.65V$

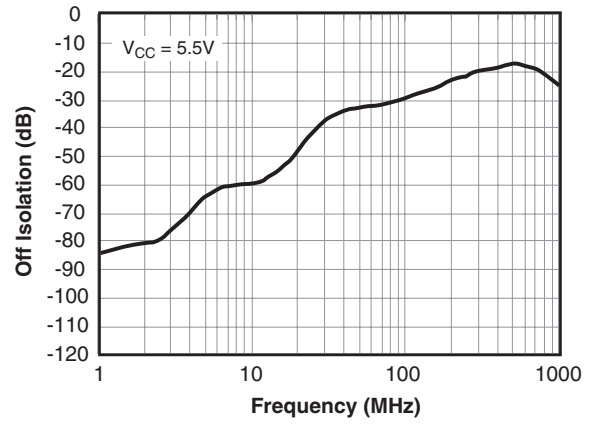

Figure 7. Off Isolation, $V_{CC} = 5.5V$

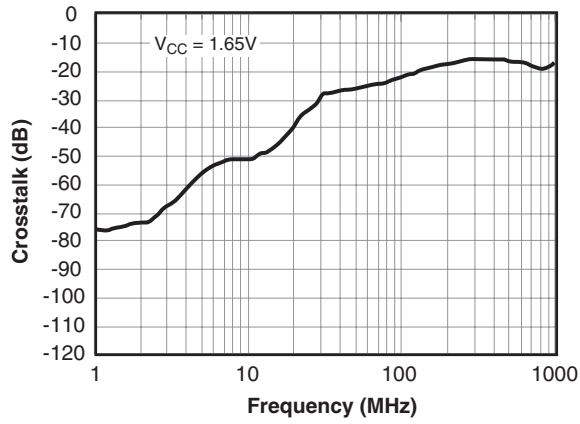

Figure 8. Crosstalk, $V_{CC} = 1.65V$

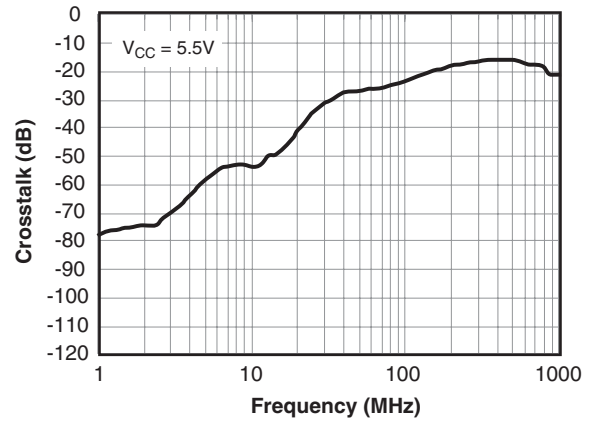

Figure 9. Crosstalk, $V_{CC} = 5.5V$

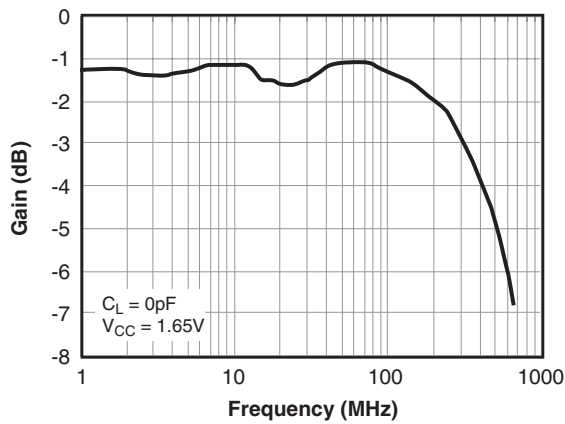

Figure 10. Bandwidth, $V_{CC} = 1.65V$

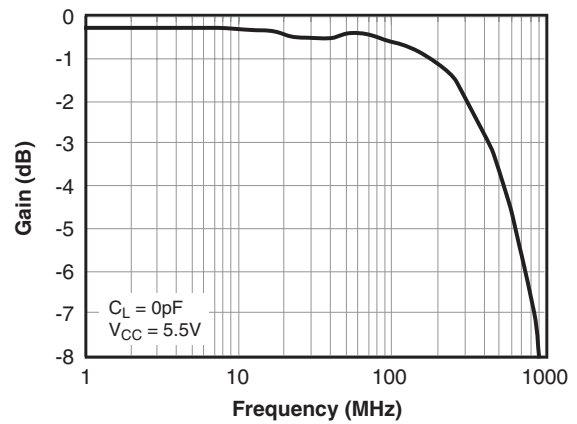
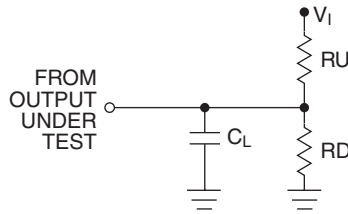

Figure 11. Bandwidth, $V_{CC} = 5.5V$

AC Loading and Waveforms



Notes:
 Input driven by 50Ω source terminated in 50Ω
 C_L includes load and stray capacitance
 Input PRR = 1.0 MHz; t_W = 500 ns

Figure 12. AC Test Circuit

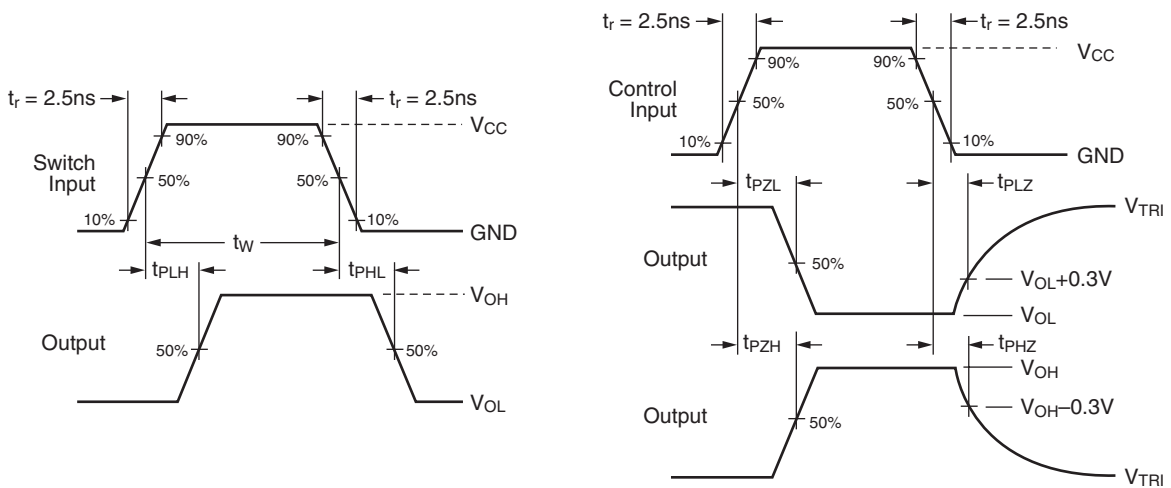

Figure 13. AC Waveforms

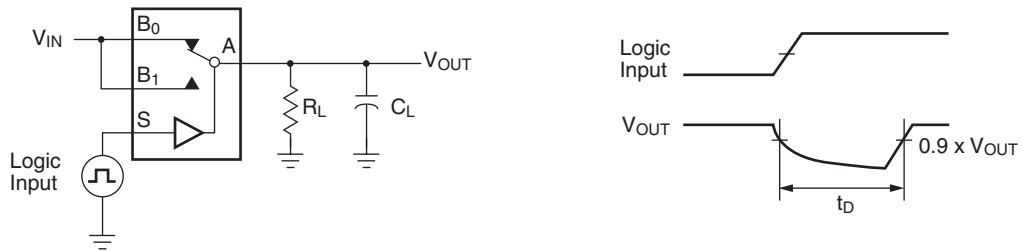

Figure 14. Break-Before-Make Interval Timing

AC Loading and Waveforms (continued)

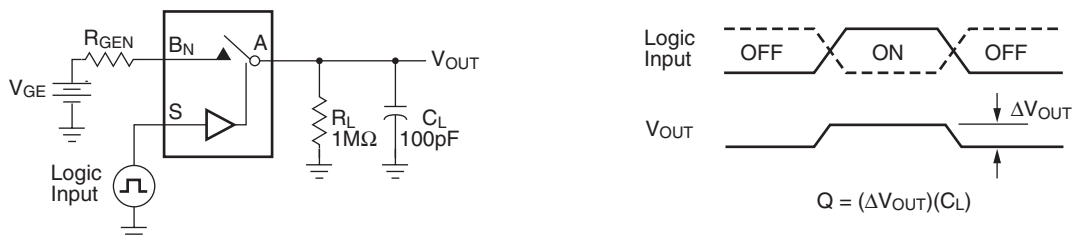

Figure 15. Charge Injection Test

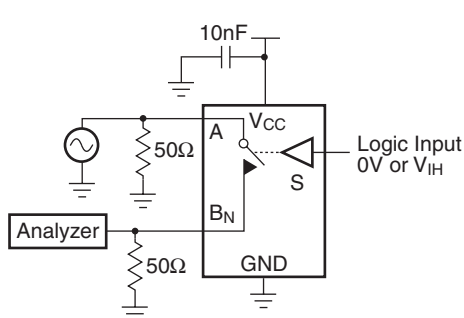

Figure 16. Off Isolation

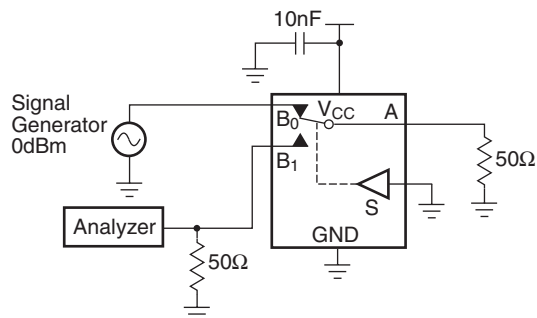

Figure 17. Crosstalk

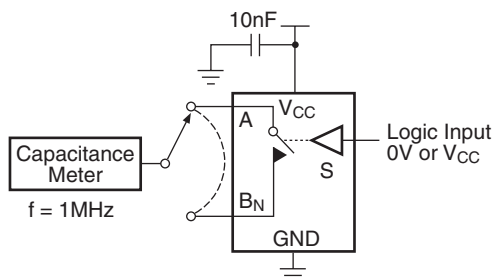

Figure 18. Channel Off Capacitance

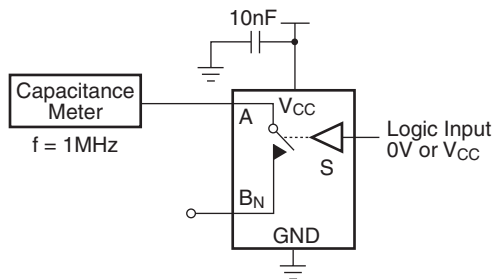

Figure 19. Channel On Capacitance

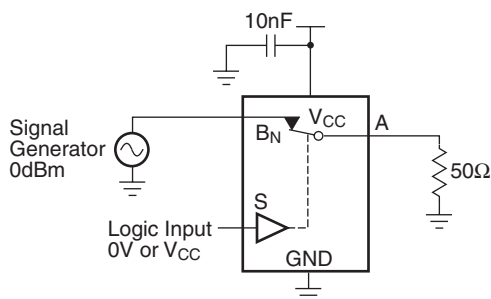
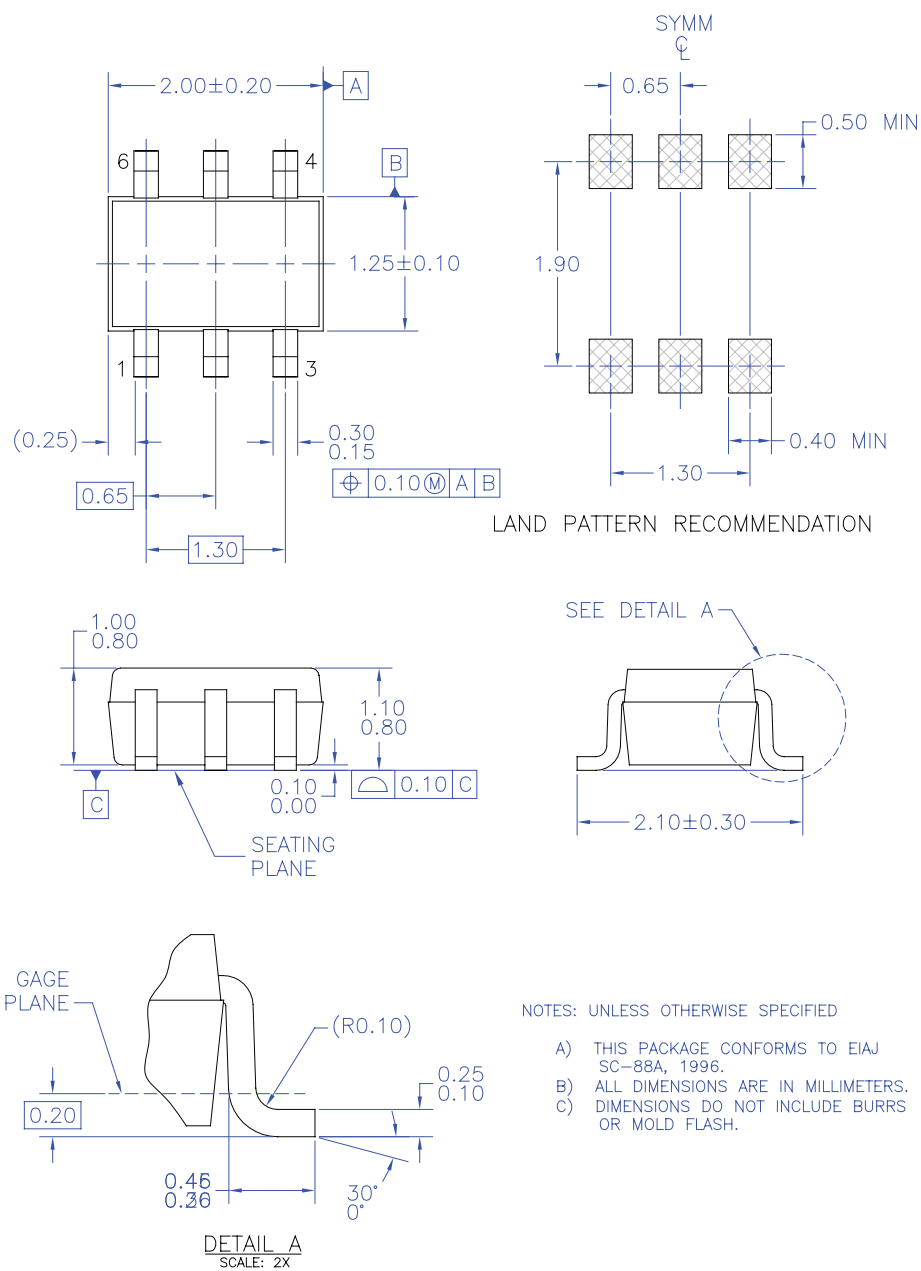

Figure 20. Bandwidth

Physical Dimensions



MAA06AREV5

Figure 21. 6-Lead, SC70, EIAJ SC88, 1.25mm Wide Package

Package drawings are provided as a service to customers considering ON Semiconductor components. Drawings may change in any manner without notice. Please note the revision and/or date on the drawing and contact a ON Semiconductor representative to verify or obtain the most recent revision. Package specifications do not expand the terms of ON Semiconductor's worldwide terms and conditions, specifically the warranty therein, which covers ON Semiconductor products.

Physical Dimensions

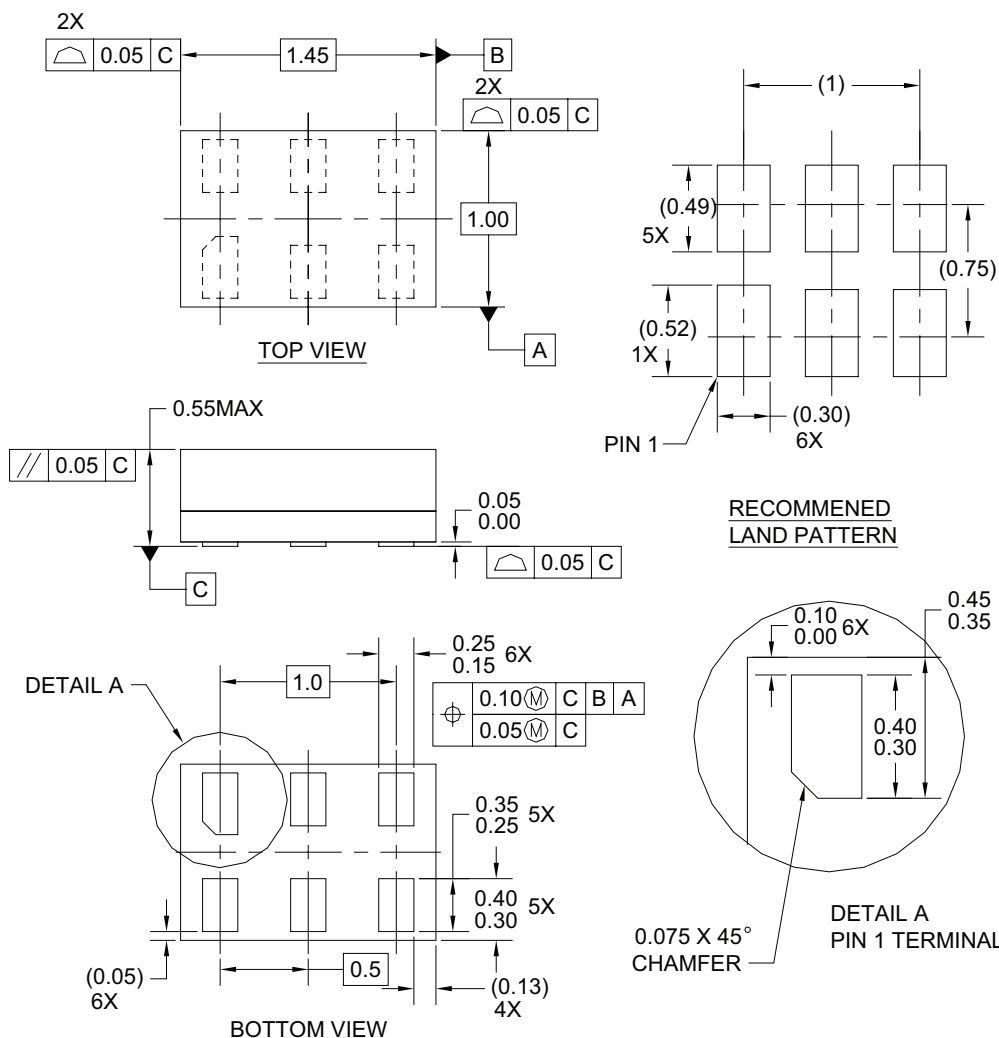

Notes:

1. CONFORMS TO JEDEC STANDARD M0-252 VARIATION UAAD
2. DIMENSIONS ARE IN MILLIMETERS
3. DRAWING CONFORMS TO ASME Y14.5M-1994

MAC06AREVC

6-Lead, MicroPak™ 1.0mm Wide Package

Package drawings are provided as a service to customers considering ON Semiconductor components. Drawings may change in any manner without notice. Please note the revision and/or date on the drawing and contact a ON Semiconductor representative to verify or obtain the most recent revision. Package specifications do not expand the terms of ON Semiconductor's worldwide terms and conditions, specifically the warranty therein, which covers ON Semiconductor products.

ON Semiconductor and  are trademarks of Semiconductor Components Industries, LLC dba ON Semiconductor or its subsidiaries in the United States and/or other countries. ON Semiconductor owns the rights to a number of patents, trademarks, copyrights, trade secrets, and other intellectual property. A listing of ON Semiconductor's product/patent coverage may be accessed at www.onsemi.com/site/pdf/Patent-Marking.pdf. ON Semiconductor reserves the right to make changes without further notice to any products herein. ON Semiconductor makes no warranty, representation or guarantee regarding the suitability of its products for any particular purpose, nor does ON Semiconductor assume any liability arising out of the application or use of any product or circuit, and specifically disclaims any and all liability, including without limitation special, consequential or incidental damages. Buyer is responsible for its products and applications using ON Semiconductor products, including compliance with all laws, regulations and safety requirements or standards, regardless of any support or applications information provided by ON Semiconductor. "Typical" parameters which may be provided in ON Semiconductor data sheets and/or specifications can and do vary in different applications and actual performance may vary over time. All operating parameters, including "Typicals" must be validated for each customer application by customer's technical experts. ON Semiconductor does not convey any license under its patent rights nor the rights of others. ON Semiconductor products are not designed, intended, or authorized for use as a critical component in life support systems or any FDA Class 3 medical devices or medical devices with a same or similar classification in a foreign jurisdiction or any devices intended for implantation in the human body. Should Buyer purchase or use ON Semiconductor products for any such unintended or unauthorized application, Buyer shall indemnify and hold ON Semiconductor and its officers, employees, subsidiaries, affiliates, and distributors harmless against all claims, costs, damages, and expenses, and reasonable attorney fees arising out of, directly or indirectly, any claim of personal injury or death associated with such unintended or unauthorized use, even if such claim alleges that ON Semiconductor was negligent regarding the design or manufacture of the part. ON Semiconductor is an Equal Opportunity/Affirmative Action Employer. This literature is subject to all applicable copyright laws and is not for resale in any manner.

PUBLICATION ORDERING INFORMATION

LITERATURE FULFILLMENT:

Literature Distribution Center for ON Semiconductor
19521 E. 32nd Pkwy, Aurora, Colorado 80011 USA
Phone: 303-675-2175 or 800-344-3860 Toll Free USA/Canada
Fax: 303-675-2176 or 800-344-3867 Toll Free USA/Canada
Email: orderlit@onsemi.com

N. American Technical Support: 800-282-9855 Toll Free
USA/Canada
Europe, Middle East and Africa Technical Support:
Phone: 421 33 790 2910
Japan Customer Focus Center
Phone: 81-3-5817-1050

ON Semiconductor Website: www.onsemi.com
Order Literature: <http://www.onsemi.com/orderlit>
For additional information, please contact your local
Sales Representative

X-ON Electronics

Largest Supplier of Electrical and Electronic Components

Click to view similar products for [Analogue Switch ICs](#) category:

Click to view products by [ON Semiconductor](#) manufacturer:

Other Similar products are found below :

[FSA3051TMX](#) [NLAS4684FCTCG](#) [NLAS5223BLMNR2G](#) [NLX2G66DMUTCG](#) [425541DB](#) [425528R](#) [099044FB](#) [NLAS5123MNR2G](#)
[PI5A4157CEX](#) [NLAS4717EPFCT1G](#) [PI5A3167CCEX](#) [SLAS3158MNR2G](#) [PI5A392AQE](#) [PI5A4157ZUEX](#) [PI5A3166TAEX](#) [FSA634UCX](#)
[XS3A1T3157GMX](#) [TC4066BP\(N,F\)](#) [DG302BDJ-E3](#) [PI5A100QEX](#) [HV2605FG-G](#) [HV2301FG-G](#) [RS2117YUTQK10](#) [RS2118YUTQK10](#)
[RS2227XUTQK10](#) [ADG452BRZ-REEL7](#) [MAX4066ESD+](#) [MAX391CPE+](#) [MAX4730EXT+T](#) [MAX314CPE+](#) [BU4066BCFV-E2](#)
[MAX313CPE+](#) [BU4S66G2-TR](#) [NLASB3157MTR2G](#) [TS3A4751PWR](#) [NLAST4599DFT2G](#) [NLAST4599DTT1G](#) [DG300BDJ-E3](#)
[DG2503DB-T2-GE1](#) [TC4W53FU\(TE12L,F\)](#) [74HC2G66DC.125](#) [DG3257DN-T1-GE4](#) [ADG619BRMZ-REEL](#) [ADG1611BRUZ-REEL7](#)
[DG2535EDQ-T1-GE3](#) [LTC201ACN#PBF](#) [74LV4066DB,118](#) [ISL43410IUZ](#) [FSA2275AUMX](#) [DIO1500WL12](#)