



Is Now Part of



ON Semiconductor®

To learn more about ON Semiconductor, please visit our website at
www.onsemi.com

Please note: As part of the Fairchild Semiconductor integration, some of the Fairchild orderable part numbers will need to change in order to meet ON Semiconductor's system requirements. Since the ON Semiconductor product management systems do not have the ability to manage part nomenclature that utilizes an underscore (_), the underscore (_) in the Fairchild part numbers will be changed to a dash (-). This document may contain device numbers with an underscore (_). Please check the ON Semiconductor website to verify the updated device numbers. The most current and up-to-date ordering information can be found at www.onsemi.com. Please email any questions regarding the system integration to Fairchild_questions@onsemi.com.

ON Semiconductor and the ON Semiconductor logo are trademarks of Semiconductor Components Industries, LLC dba ON Semiconductor or its subsidiaries in the United States and/or other countries. ON Semiconductor owns the rights to a number of patents, trademarks, copyrights, trade secrets, and other intellectual property. A listing of ON Semiconductor's product/patent coverage may be accessed at www.onsemi.com/site/pdf/Patent-Marking.pdf. ON Semiconductor reserves the right to make changes without further notice to any products herein. ON Semiconductor makes no warranty, representation or guarantee regarding the suitability of its products for any particular purpose, nor does ON Semiconductor assume any liability arising out of the application or use of any product or circuit, and specifically disclaims any and all liability, including without limitation special, consequential or incidental damages. Buyer is responsible for its products and applications using ON Semiconductor products, including compliance with all laws, regulations and safety requirements or standards, regardless of any support or applications information provided by ON Semiconductor. "Typical" parameters which may be provided in ON Semiconductor data sheets and/or specifications can and do vary in different applications and actual performance may vary over time. All operating parameters, including "Typicals" must be validated for each customer application by customer's technical experts. ON Semiconductor does not convey any license under its patent rights nor the rights of others. ON Semiconductor products are not designed, intended, or authorized for use as a critical component in life support systems or any FDA Class 3 medical devices or medical devices with a same or similar classification in a foreign jurisdiction or any devices intended for implantation in the human body. Should Buyer purchase or use ON Semiconductor products for any such unintended or unauthorized application, Buyer shall indemnify and hold ON Semiconductor and its officers, employees, subsidiaries, affiliates, and distributors harmless against all claims, costs, damages, and expenses, and reasonable attorney fees arising out of, directly or indirectly, any claim of personal injury or death associated with such unintended or unauthorized use, even if such claim alleges that ON Semiconductor was negligent regarding the design or manufacture of the part. ON Semiconductor is an Equal Opportunity/Affirmative Action Employer. This literature is subject to all applicable copyright laws and is not for resale in any manner.



NC7SB3257

2:1 Multiplexer/Demultiplexer Bus Switch

Features

- Space Saving SC70 6-Lead Surface Mount Package
- Typical 3 Ω Switch Resistance at 5.0 V V_{CC}
- Minimal Propagation Delay through the Switch
- Power-Down High Impedance Control Input
- Zero Bounce in Flow through Mode
- TTL Compatible Control Input
- Over-Voltage Tolerance of Control Input to 7.0 V
- Break-before-Make Enable Circuitry

Description

The NC7SB3257 is a high performance, 2:1 NMOS passgate multiplexer/demultiplexer. The device is fabricated with advanced sub-micron CMOS technology to achieve high speed enable and disable times and low On Resistance. The device is specified to operate over the 4.0 to 5.5 V V_{CC} operating range.

The control input tolerates voltages up to 5.5 V independent of the V_{CC} operating range.

Ordering Information

Part Number	Top Mark	Package	Packing Method
NC7SB3257P6X	B7B	6-Lead SC70, EIAJ SC88, 1.25 mm Wide	3000 Units on Tape & Reel

Logic Symbol

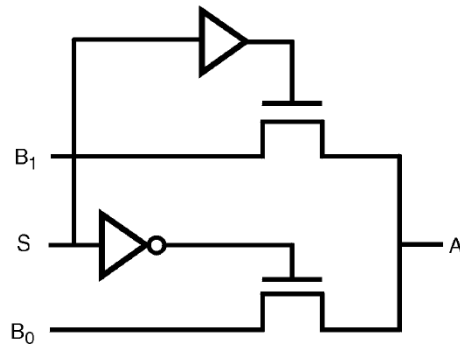

Figure 1. Logic Symbol

Pin Configurations

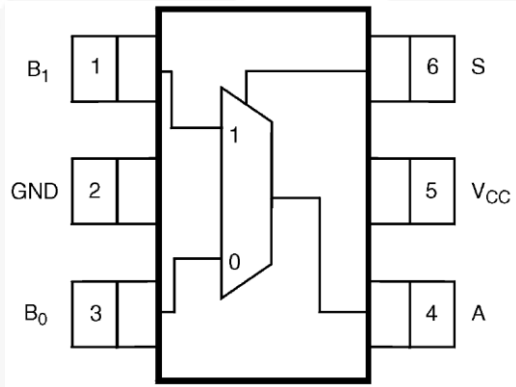

Figure 2. SC70 (Top View)

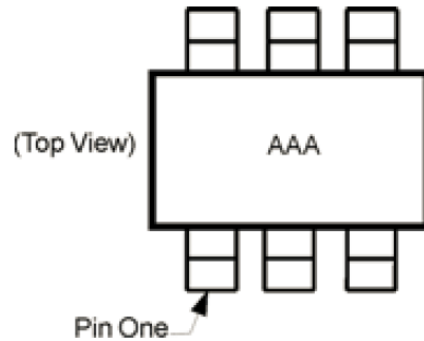

Figure 3. Pin One Orientation Diagram^(1, 2)

Notes:

1. Orientation of Top Mark determines Pin One location. Read the top product code mark left to right, Pin One is the lower left pin.
2. AAA - Product Code Top Mark - see ordering code.

Pin Definitions

Pin #	Name	Description
1	B ₁	Data Ports
2	GND	Ground
3	B ₀	Data Ports
4	A	Data Ports
6	V _{CC}	Supply Voltage
5	S	Control Input

Function Table

Inputs	Functions
L	B ₀ Connected to A
H	B ₁ Connected to A

H = HIGH Logic Level.

L = LOW Logic Level.

Absolute Maximum Ratings

Stresses exceeding the absolute maximum ratings may damage the device. The device may not function or be operable above the recommended operating conditions and stressing the parts to these levels is not recommended. In addition, extended exposure to stresses above the recommended operating conditions may affect device reliability. The absolute maximum ratings are stress ratings only.

Symbol	Parameter	Min.	Max.	Unit
V_{CC}	Supply Voltage	-0.5	7.0	V
V_S	DC Switch Voltage	-0.5	7.0	V
V_{IN}	DC Input Voltage ⁽³⁾	-0.5	7.0	V
I_{IK}	DC Input Diode Current		-50	mA
	$V_{IN} < 0\text{ V}$			
I_{OUT}	DC Output Current		128	mA
I_{CC} OR I_{GND}	DC V_{CC} or Ground Current		±100	mA
T_{STG}	Storage Temperature Range	-65	+150	°C
T_J	Junction Lead Temperature under Bias		+150	°C
T_L	Lead Temperature (Soldering, 10 Seconds)		+260	°C
P_D	Power Dissipation at +85°C		180	mW

Note:

- The input and output negative voltage ratings may be exceeded if the input and output diode current ratings are observed.

Recommended Operating Conditions⁽⁴⁾

The Recommended Operating Conditions table defines the conditions for actual device operation. Recommended operating conditions are specified to ensure optimal performance to the datasheet specifications. Fairchild does not recommend exceeding them or designing to Absolute Maximum Ratings.

Symbol	Parameter	Conditions	Min.	Max.	Unit
V_{CC}	Supply Voltage Operating		4.0	5.5	V
V_{IN}	Control Input Voltage		0	V_{CC}	V
	Switch Input Voltage		0	V_{CC}	V
V_{OUT}	Output Voltage		0	V_{CC}	V
T_A	Operating Temperature		-40	+85	°C
t_r, t_f	Input Rise and Fall Times	Control Input $V_{CC} = 4.0\text{ V to }5.5\text{ V}$	0	5	ns/V
θ_{JA}	Thermal Resistance			350	°C/W

Note:

- Control input must be held HIGH or LOW, it must not float.

DC Electrical Characteristics

Symbol	Parameter	Conditions	V _{CC}	T _A =-40 to +85°C			Unit
				Min.	Typ.	Max.	
V _{IK}	Clamp Diode Voltage	I _{IN} = -18 mA	4.5			-1.2	V
V _{IH}	HIGH Level Input Voltage		4.5 to 5.5	2.0			V
V _{IL}	LOW Level Input Voltage		4.5 to 5.5			0.8	V
I _{IN}	Input Leakage Current	0 ≤ V _{IN} ≤ 5.5 V	5.5			±1.0	μA
I _{OFF}	OFF State Leakage Current	0 ≤ A, B ≤ V _{CC}	5.5			±1.0	μA
R _{ON}	Switch On Resistance ⁽⁵⁾	V _{IN} = 0 V, I _{IN} = 64 mA	4.5		3.0	7.0	Ω
		V _{IN} = 0 V, I _{IN} = 30 mA	4.5		3.0	7.0	
		V _{IN} = 2.4 V, I _{IN} = 15 mA	4.5		6.0	15.0	
		V _{IN} = 2.4 V, I _{IN} = 15 mA	4.0		10.0	20.0	
I _{CC}	Quiescent Supply Current	V _{IN} = V _{CC} or GND I _{OUT} = 0	5.5			10.0	μA
ΔI _{CC}	Increase in I _{CC} per Input ⁽⁶⁾	V _{IN} = 3.4 V, I _O = 0 Control Input Only	5.5		0.9	2.5	mA

Notes:

- Measured by the voltage drop between A and B pins at the indicated current through the switch. On Resistance is determined by the lower of the voltages on the two (A or B Ports).
- Per TTL driven Input (V_{IN} = 3.4 V, Control input only). A and B pins do not contribute to I_{CC}.

AC Electrical Characteristics

Symbol	Parameter	V _{CC} (V)	Conditions	T _A =-40°C to +85°C, C _L = 50 pF, R _U =R _D = 500 Ω			Unit
				Min.	Typ.	Max.	
t _{PHL} , t _{PLH}	Propagation Delay Bus-to-Bus ⁽⁷⁾	4.0-5.5	V _I = OPEN			0.25	ns
t _{PZL} , t _{PZH}	Output Enable Time	4.0-5.5	V _I = 7 V for t _{PZL}	1.8		6.5	ns
		4.0	V _I = 0 V for t _{PZH}	1.8		7.3	
t _{PLZ} , t _{PHZ}	Output Disable Time	4.5-5.5	V _I = 7 V for t _{PLZ}	0.8		4.7	ns
		4.0	V _I = 0 V for t _{PHZ}	0.8		5.3	
t _{B-M}	Break-before-Make Time ⁽⁸⁾	4.5-5.5		0.5			ns
		4.0		0.5			

Notes:

- This parameter is guaranteed by design but not tested. The bus switch contributes no propagation delay other than the RC delay of the On Resistance of the switch and the 50 pF load capacitance, when driven by an ideal voltage source (zero output impedance).
- Guaranteed by design.

Capacitance⁽⁹⁾

Symbol	Parameter	Conditions	Typ.	Unit
C _{IN}	Control Pin Input Capacitance	V _{CC} = 0.0 V	2.3	pF
C _{IO-B}	B Port OFF Capacitance	V _{CC} = 5.0 V	5.7	pF
C _{IO-A}	A Port ON Capacitance	V _{CC} = 5.0 V	16.0	pF

Note:

- Capacitance is characterized but not tested.

AC Loading and Waveforms

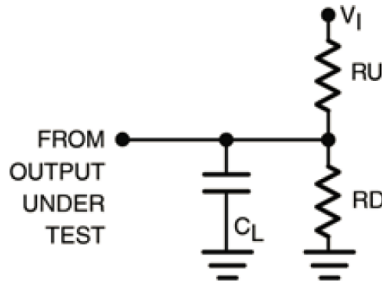

Note:

Input Driven by 50 Ω source terminated in 50 Ω.
 C_L includes load and stray capacitance.
 Input PRR=10 MHz; $t_w=500$ ns.

Figure 4. AC Test Circuit

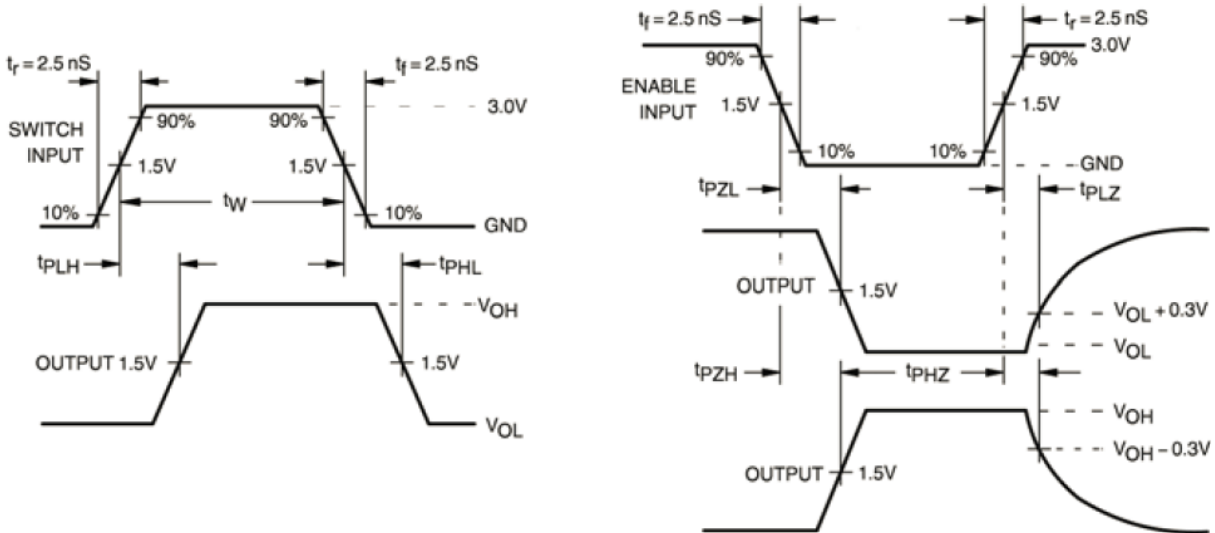

Note:

Input = AC Waveform;
 PRR = Variable; Duty Cycle = 50%

Figure 5. AC Waveforms

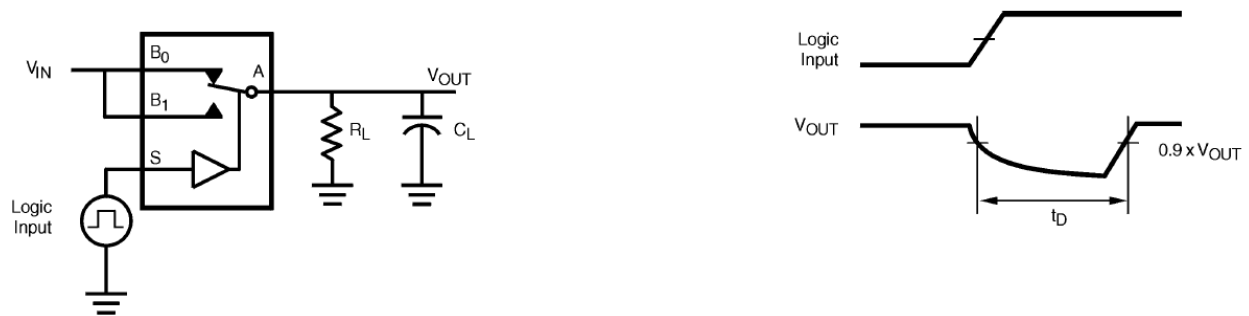

Figure 6. Break-Before-Make Interval Timing

ON Semiconductor and  are trademarks of Semiconductor Components Industries, LLC dba ON Semiconductor or its subsidiaries in the United States and/or other countries. ON Semiconductor owns the rights to a number of patents, trademarks, copyrights, trade secrets, and other intellectual property. A listing of ON Semiconductor's product/patent coverage may be accessed at www.onsemi.com/site/pdf/Patent-Marking.pdf. ON Semiconductor reserves the right to make changes without further notice to any products herein. ON Semiconductor makes no warranty, representation or guarantee regarding the suitability of its products for any particular purpose, nor does ON Semiconductor assume any liability arising out of the application or use of any product or circuit, and specifically disclaims any and all liability, including without limitation special, consequential or incidental damages. Buyer is responsible for its products and applications using ON Semiconductor products, including compliance with all laws, regulations and safety requirements or standards, regardless of any support or applications information provided by ON Semiconductor. "Typical" parameters which may be provided in ON Semiconductor data sheets and/or specifications can and do vary in different applications and actual performance may vary over time. All operating parameters, including "Typicals" must be validated for each customer application by customer's technical experts. ON Semiconductor does not convey any license under its patent rights nor the rights of others. ON Semiconductor products are not designed, intended, or authorized for use as a critical component in life support systems or any FDA Class 3 medical devices or medical devices with a same or similar classification in a foreign jurisdiction or any devices intended for implantation in the human body. Should Buyer purchase or use ON Semiconductor products for any such unintended or unauthorized application, Buyer shall indemnify and hold ON Semiconductor and its officers, employees, subsidiaries, affiliates, and distributors harmless against all claims, costs, damages, and expenses, and reasonable attorney fees arising out of, directly or indirectly, any claim of personal injury or death associated with such unintended or unauthorized use, even if such claim alleges that ON Semiconductor was negligent regarding the design or manufacture of the part. ON Semiconductor is an Equal Opportunity/Affirmative Action Employer. This literature is subject to all applicable copyright laws and is not for resale in any manner.

PUBLICATION ORDERING INFORMATION

LITERATURE FULFILLMENT:

Literature Distribution Center for ON Semiconductor
19521 E. 32nd Pkwy, Aurora, Colorado 80011 USA
Phone: 303-675-2175 or 800-344-3860 Toll Free USA/Canada
Fax: 303-675-2176 or 800-344-3867 Toll Free USA/Canada
Email: orderlit@onsemi.com

N. American Technical Support: 800-282-9855 Toll Free
USA/Canada
Europe, Middle East and Africa Technical Support:
Phone: 421 33 790 2910
Japan Customer Focus Center
Phone: 81-3-5817-1050

ON Semiconductor Website: www.onsemi.com
Order Literature: <http://www.onsemi.com/orderlit>
For additional information, please contact your local
Sales Representative

X-ON Electronics

Largest Supplier of Electrical and Electronic Components

Click to view similar products for [Encoders, Decoders, Multiplexers & Demultiplexers](#) *category:*

Click to view products by [ON Semiconductor](#) *manufacturer:*

Other Similar products are found below :

[MC74HC163ADTG](#) [74HC253N](#) [NLV74VHC1G01DFT1G](#) [TC74AC138P\(F\)](#) [NLV14051BDR2G](#) [NLV74HC238ADTR2G](#) [COMX-CAR-210](#)
[5962-8607001EA](#) [NTE74LS247](#) [5962-8756601EA](#) [SN74LS148N](#) [8CA3052APGGI8](#) [TC74VHC138F\(EL,K,F](#) [PI3B3251LE](#) [PI3B3251QE](#)
[NTE4028B](#) [NTE4514B](#) [NTE4515B](#) [NTE4543B](#) [NTE4547B](#) [NTE74LS249](#) [NLV74HC4851AMNTWG](#) [MC74LVX257DG](#)
[M74HCT4851ADWR2G](#) [AP4373AW5-7-01](#) [NL7SZ19DBVT1G](#) [MC74LVX257DTR2G](#) [74VHC4066AFT\(BJ\)](#) [74VHCT138AFT\(BJ\)](#)
[74HC158D.652](#) [74HC4052D\(BJ\)](#) [74VHC138MTC](#) [COMX-CAR-P1](#) [JM38510/65852BEA](#) [74VHC138MTCX](#) [74HC138D\(BJ\)](#)
[NL7SZ19DFT2G](#) [74AHCT138T16-13](#) [74LCX138FT\(AJ\)](#) [74LCX157FT\(AJ\)](#) [NL7SZ18MUR2G](#) [PCA9540BD,118](#) [QS3VH16233PAG8](#)
[SNJ54HC251J](#) [SN54LS139AJ](#) [SN74CBTLV3257PWG4](#) [SN74ALS156DR](#) [SN74AHCT139PWR](#) [74HC251D.652](#) [74HC257D.652](#)