

NCN26010BMNEVB 10BASE-T1S Power Supply and Adapter Board User's Manual

EVBUM2834/D

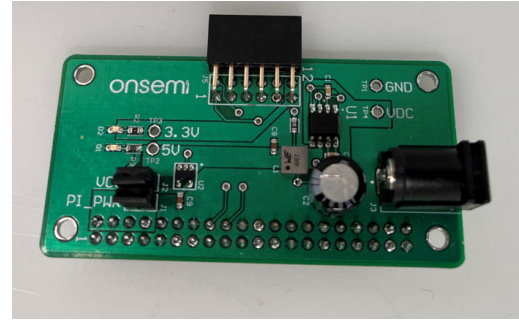

Figure 1. Board Photo

Introduction

The NCN26010BMNEVB is a PCB designed to allow customers to connect to onsemi's NCN26010XMNEVB 10BASE-T1S SPI enabled 10BASE-T1S MACPHY Evaluation board to Raspberry Pi single board computers (SBC). Its main purpose is to act as a physical interface adapter, routing the PMOD connection of the NCN26010XMNEVB to the appropriate pins on the 40 pin Raspberry Pi SBC.

Features

The NCN26010BMNEVB bridge board includes all circuitry to allow powering both a Raspberry Pi and an onsemi NCN26010XMNEVB 10BASE-T1S MACPHY

evaluation board as well as establish a connection between the MAPHY evaluation board and the Raspberry Pi. It features a DC/DC SMPS buck converter (NCV891330PD50R2G) that accepts any voltage between 8V and 28V and generates a regulated 5V supply, capable of sourcing 3A of continuous current. This is sufficient to power any Raspberry Pi model available today.

The board also contains a linear 3.3 V Voltage regulator (NCP115ASN330T2G) that provides a stable 3.3 V supply to the Connected 10BASE-T1S MACPHY evaluation board.

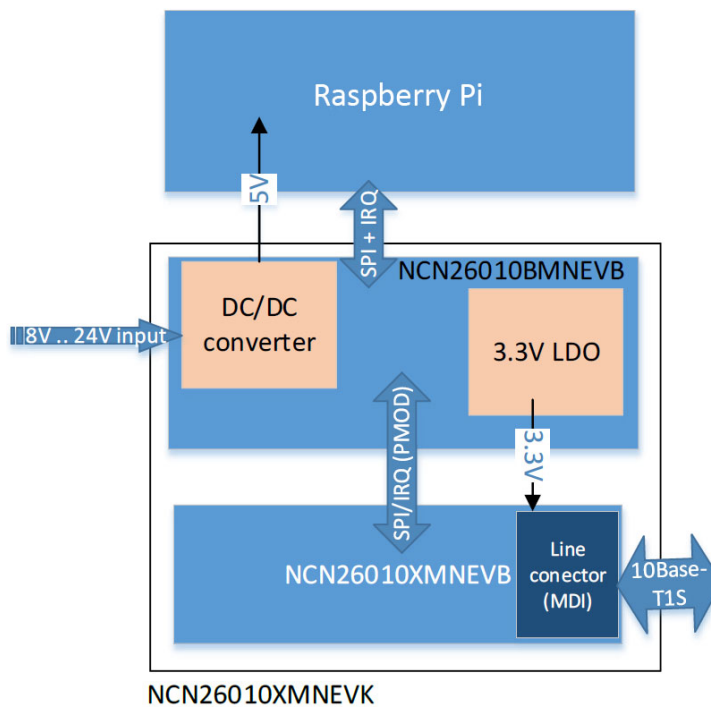

Figure 2. Evaluation Kit Simplified Block Diagram

EVBUM2834/D

APPLICATIONS INFORMATION

Together with the NCN26010XMNEVB, the bridge board NCN26010BMNEVB builds an evaluation kit also available as NCN26010XMNEVK.

Connectors and Jumper Locations

The following picture shows the top view of the EVB:

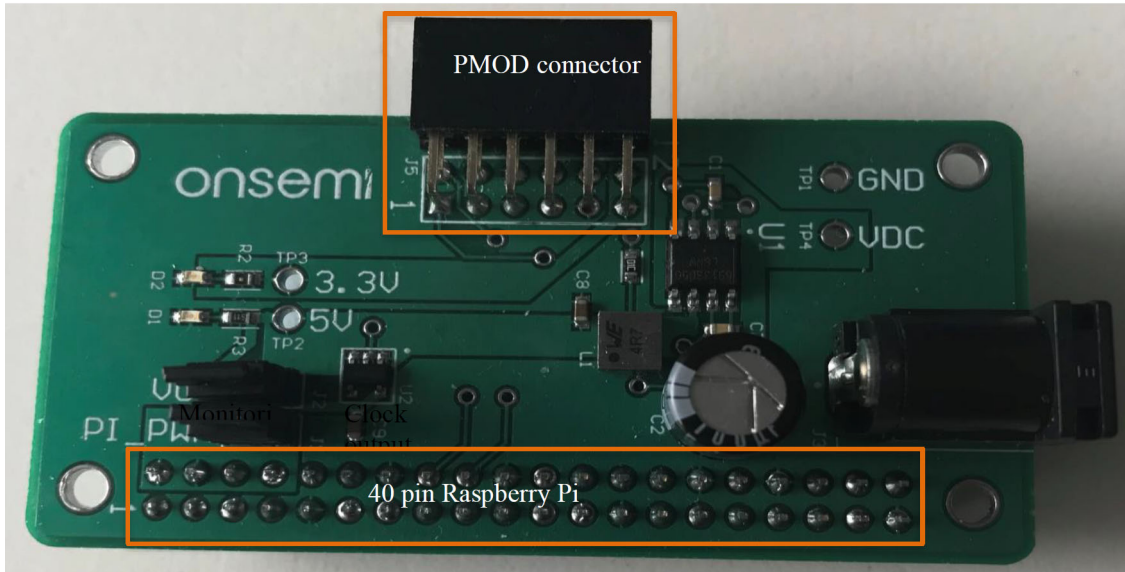

Figure 3. NCN26010BMNEVB "Bridge" Board

When connected to a complete node, the setup is as shown in Figure 4.

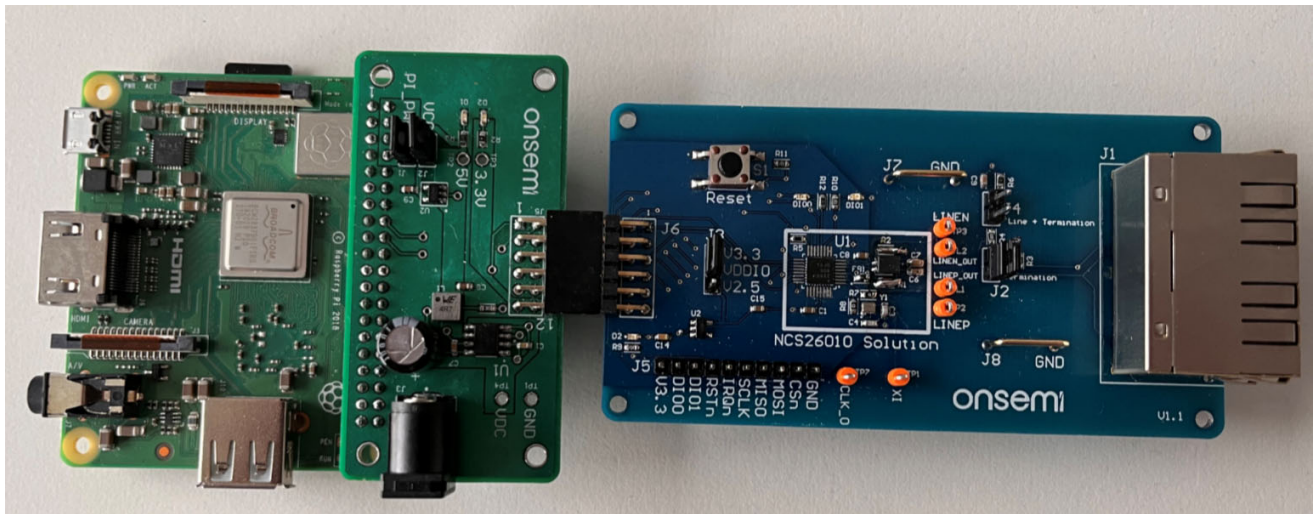

Figure 4. Raspberry Pi 3A+ connected to the Evaluation Kit consisting of NCN26010BMNEVB and NCN26010XMNEVB

EVBUM2834/D

Power Supply, Test Points and Connectors

NCN26010BMNEVB can be powered through the J3 Barrel Connector. The input voltage can be anywhere between 8 V and 28 V. The pin inside the barrel connector connects to VDC.

Following is a list of all connectors and test points on the NCN26010BMNEVB evaluation board.

Table 1. TEST POINTS AND JUMPERS

Name on Board	Function	Comment
TP1	GND	Ground connection
TP2	VDC	Can be used to measure the input voltage VDC (8 V to 28 V). Users could also use this test point for feeding the input voltage to the board. This way power would not have to enter from the J3 barrel connector.
TP3	3.3V	This test point can be used to monitor the VCC voltage being passed to the PMOD connector.
TP4	5V	TP4 can be used to monitor the 5 V output of the DC/DC converter on the bridge board
J1	PI_PWR	When both the NCN26010XMNEVB and the Raspberry Pi are powered by their own external power supplies, this jumper needs to be left open. When the Raspberry Pi is powered from its micro-USB port and should also provide power to the MACPHY evaluation board connected via the J5 PMOD connector, then this jumper needs to be closed. When powering the entire setup with the bridge board's DC/DC converter, the jumper also needs to be closed.
J2	VCC	To power a MACPHY evaluation board through the PMOD connector, J2 needs to be closed. Otherwise, it needs to be left open, if the MACHY evaluation board is powered by an external power supply. J2 can also be used to do current measurements of the connected NCN26010XMNEVB, by connecting a current meter instead of closing the jumper.
J5	PMOD	PMOD master connector. Pinned out to work with NCN26010XMNEVB evaluation board
Pi	Raspberry Pi	40 pin Raspberry Pi connector. Plugs in to a Raspberry Pi SBC.

For pinout of the PMOD and the Raspberry Pi connectors refer to the board schematic and the bottom of this document. Note that the connections match the appropriate Raspberry Pi and NCN26010XMNEVB connectors.

EVBUM2834/D

NCN26010BMNEVB Schematic

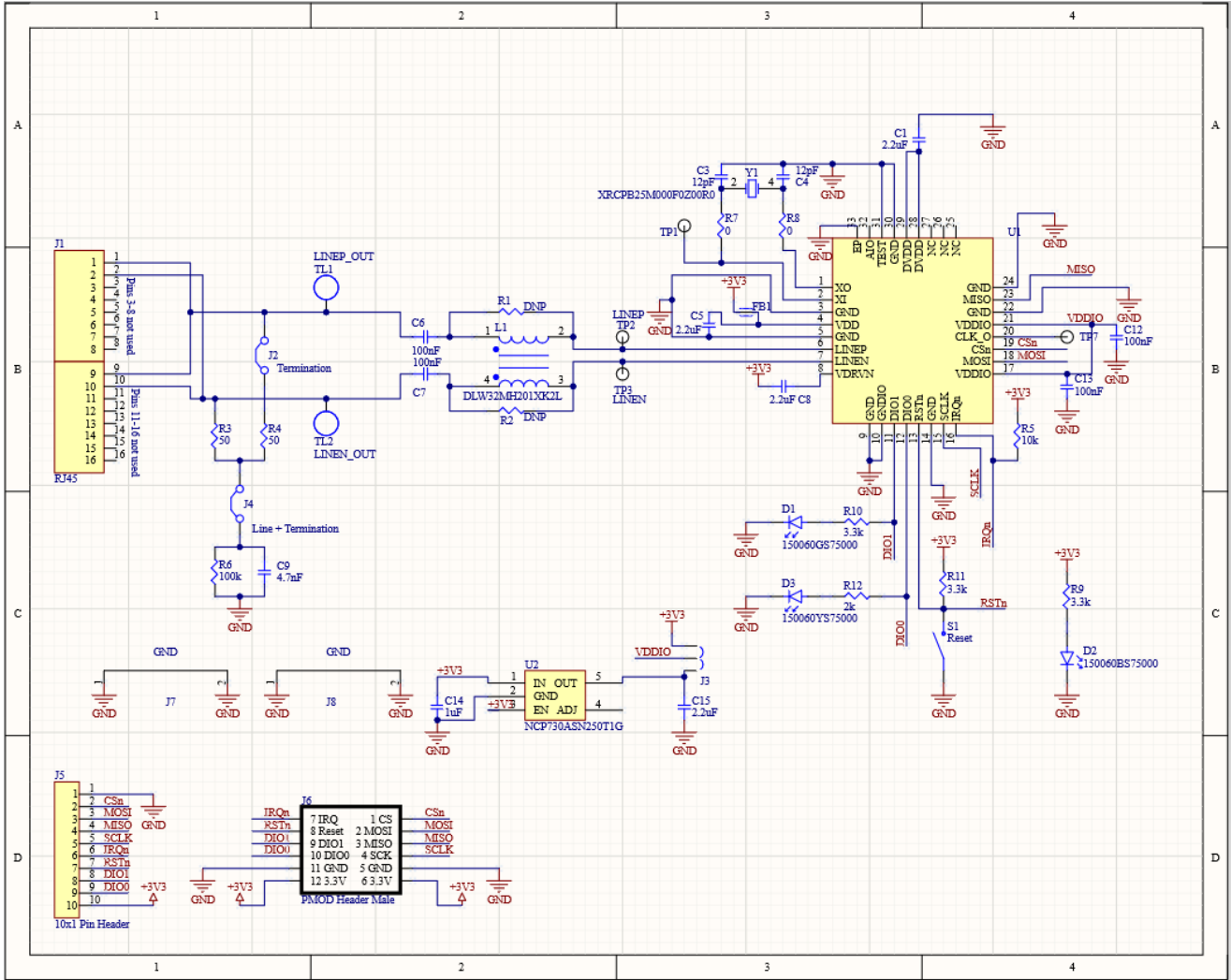

Figure 5. NCN26010BMNEVB Schematic

All brand names and product names appearing in this document are registered trademarks or trademarks of their respective holders.

onsemi, **Onsemi**, and other names, marks, and brands are registered and/or common law trademarks of Semiconductor Components Industries, LLC dba "**onsemi**" or its affiliates and/or subsidiaries in the United States and/or other countries. **onsemi** owns the rights to a number of patents, trademarks, copyrights, trade secrets, and other intellectual property. A listing of **onsemi**'s product/patent coverage may be accessed at www.onsemi.com/site/pdf/Patent-Marking.pdf. **onsemi** is an Equal Opportunity/Affirmative Action Employer. This literature is subject to all applicable copyright laws and is not for resale in any manner.

The evaluation board/kit (research and development board/kit) (hereinafter the "board") is not a finished product and is not available for sale to consumers. The board is only intended for research, development, demonstration and evaluation purposes and will only be used in laboratory/development areas by persons with an engineering/technical training and familiar with the risks associated with handling electrical/mechanical components, systems and subsystems. This person assumes full responsibility/liability for proper and safe handling. Any other use, resale or redistribution for any other purpose is strictly prohibited.

THE BOARD IS PROVIDED BY ONSEMI TO YOU "AS IS" AND WITHOUT ANY REPRESENTATIONS OR WARRANTIES WHATSOEVER. WITHOUT LIMITING THE FOREGOING, ONSEMI (AND ITS LICENSORS/SUPPLIERS) HEREBY DISCLAIMS ANY AND ALL REPRESENTATIONS AND WARRANTIES IN RELATION TO THE BOARD, ANY MODIFICATIONS, OR THIS AGREEMENT, WHETHER EXPRESS, IMPLIED, STATUTORY OR OTHERWISE, INCLUDING WITHOUT LIMITATION ANY AND ALL REPRESENTATIONS AND WARRANTIES OF MERCHANTABILITY, FITNESS FOR A PARTICULAR PURPOSE, TITLE, NON-INFRINGEMENT, AND THOSE ARISING FROM A COURSE OF DEALING, TRADE USAGE, TRADE CUSTOM OR TRADE PRACTICE.

onsemi reserves the right to make changes without further notice to any board.

You are responsible for determining whether the board will be suitable for your intended use or application or will achieve your intended results. Prior to using or distributing any systems that have been evaluated, designed or tested using the board, you agree to test and validate your design to confirm the functionality for your application. Any technical, applications or design information or advice, quality characterization, reliability data or other services provided by **onsemi** shall not constitute any representation or warranty by **onsemi**, and no additional obligations or liabilities shall arise from **onsemi** having provided such information or services.

onsemi products including the boards are not designed, intended, or authorized for use in life support systems, or any FDA Class 3 medical devices or medical devices with a similar or equivalent classification in a foreign jurisdiction, or any devices intended for implantation in the human body. You agree to indemnify, defend and hold harmless **onsemi**, its directors, officers, employees, representatives, agents, subsidiaries, affiliates, distributors, and assigns, against any and all liabilities, losses, costs, damages, judgments, and expenses, arising out of any claim, demand, investigation, lawsuit, regulatory action or cause of action arising out of or associated with any unauthorized use, even if such claim alleges that **onsemi** was negligent regarding the design or manufacture of any products and/or the board.

This evaluation board/kit does not fall within the scope of the European Union directives regarding electromagnetic compatibility, restricted substances (RoHS), recycling (WEEE), FCC, CE or UL, and may not meet the technical requirements of these or other related directives.

FCC WARNING – This evaluation board/kit is intended for use for engineering development, demonstration, or evaluation purposes only and is not considered by **onsemi** to be a finished end product fit for general consumer use. It may generate, use, or radiate radio frequency energy and has not been tested for compliance with the limits of computing devices pursuant to part 15 of FCC rules, which are designed to provide reasonable protection against radio frequency interference. Operation of this equipment may cause interference with radio communications, in which case the user shall be responsible, at its expense, to take whatever measures may be required to correct this interference.

onsemi does not convey any license under its patent rights nor the rights of others.

LIMITATIONS OF LIABILITY: **onsemi** shall not be liable for any special, consequential, incidental, indirect or punitive damages, including, but not limited to the costs of requalification, delay, loss of profits or goodwill, arising out of or in connection with the board, even if **onsemi** is advised of the possibility of such damages. In no event shall **onsemi**'s aggregate liability from any obligation arising out of or in connection with the board, under any theory of liability, exceed the purchase price paid for the board, if any.

The board is provided to you subject to the license and other terms per **onsemi**'s standard terms and conditions of sale. For more information and documentation, please visit www.onsemi.com.

PUBLICATION ORDERING INFORMATION

LITERATURE FULFILLMENT:

Email Requests to: orderlit@onsemi.com

onsemi Website: www.onsemi.com

TECHNICAL SUPPORT

North American Technical Support:

Voice Mail: 1 800-282-9855 Toll Free USA/Canada

Phone: 011 421 33 790 2910

Europe, Middle East and Africa Technical Support:

Phone: 00421 33 790 2910

For additional information, please contact your local Sales Representative

X-ON Electronics

Largest Supplier of Electrical and Electronic Components

Click to view similar products for [Power Management IC Development Tools](#) *category:*

Click to view products by [ON Semiconductor](#) *manufacturer:*

Other Similar products are found below :

[EVB-EP5348UI](#) [DA9063-EVAL](#) [BQ24155EVM](#) [BQ25010EVM](#) [REG710EVM-5](#) [TPS54980EVM-022](#) [TPS65010EVM-230](#) [BQ24120EVM-001](#) [BQ24212EVM-678](#) [BQ3050EVM-001](#) [ISL9520EVAL1Z](#) [UCC3809EVM](#) [LM3691TL-1.2EV/NOPB](#) [SOT23-3EV-VREG](#) [SOT89-3EV-VREG](#) [TPS2458EVM](#) [TPS54229EEVM-056](#) [TPS54329EEVM-056](#) [MAX8556EVKIT](#) [MAX20012EVKIT#](#) [MAX15005AEVKIT+](#) [S6SBP203A8FVA1001](#) [TPS652510EVM](#) [STEVAL-ISA047V1](#) [ISL8502AEVAL1Z](#) [ISL8009AEVAL1Z](#) [TPS76901EVM-127](#) [FRDM-HB2001-EVM](#) [BM6208FS-EVK-001](#) [LM5115EVAL](#) [LP5900TL-2.5EV](#) [DRI0043](#) [7E.12.8.230.0002](#) [KITPF8100FRDMEVM](#) [NCP10671B05GEVB](#) [MAX20073EVKIT#](#) [EVB-EN6337QA](#) [AP3125AEV1](#) [NIV6350MT2GEVB](#) [XMCA1](#) [RD33771-48VEVM](#) [EVKT-MPM3695-10-A](#) [DEMO200W12VDCLLC](#) [SAMPLEBOXILD8150TOBO1](#) [MAX18066EVKIT#](#) [AP61100Z6-EVM](#) [AP62300WU-EVM](#) [KIT8020-CRD-8FF1217P-1](#) [KITPF8121FRDMEVM](#) [EV2174C-G-00A](#)