

# Integrated DC-DC Converter - Power over Ethernet and Telecom

## NCP1030, NCP1031

The NCP1030 and NCP1031 are a family of miniature high-voltage monolithic switching regulators with on-chip Power Switch and Startup Circuits. The NCP103x family incorporates in a single IC all the active power, control logic and protection circuitry required to implement, with minimal external components, several switching regulator applications, such as a secondary side bias supply or a low power dc-dc converter. This controller family is ideally suited for 48 V telecom, 42 V automotive and 12 V input applications. The NCP103x can be configured in any single-ended topology such as forward or flyback. The NCP1030 is targeted for applications requiring up to 3 W, and the NCP1031 is targeted for applications requiring up to 6 W.

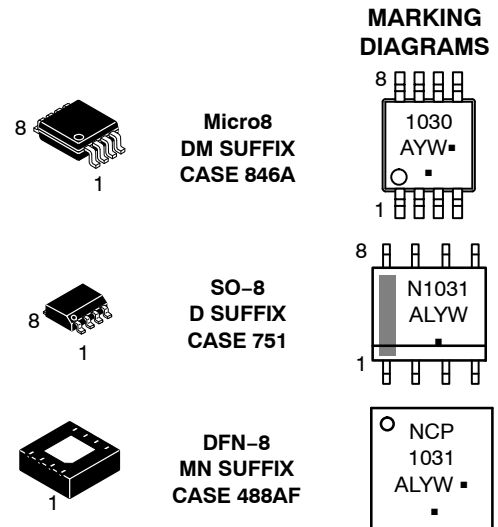
The internal error amplifier allows the NCP103x family to be easily configured for secondary or primary side regulation operation in isolated and non-isolated configurations. The fixed frequency oscillator is optimized for operation up to 1 MHz and is capable of external frequency synchronization, providing additional design flexibility. In addition, the NCP103x incorporates individual line undervoltage and overvoltage detectors, cycle by cycle current limit and thermal shutdown to protect the controller under fault conditions. The preset current limit thresholds eliminate the need for external sensing components.

### Features

- On Chip High 200 V Power Switch Circuit and Startup Circuit
- Internal Startup Regulator with Auxiliary Winding Override
- Operation up to 1 MHz
- External Frequency Synchronization Capability
- Frequency Fold-down Under Fault Conditions
- Trimmed  $\pm 2\%$  Internal Reference
- Line Undervoltage and Overvoltage Detectors
- Cycle by Cycle Current Limit Using SENSEFET<sup>®</sup>
- Active LEB Circuit
- Overtemperature Protection
- Internal Error Amplifier
- Pb-Free Packages are Available

### Typical Applications

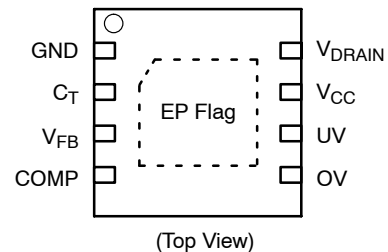
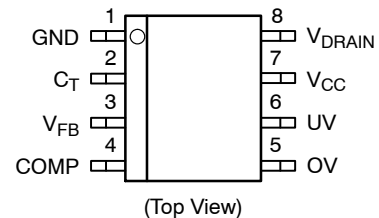
- POE (Power Over Ethernet)/PD. Refer to Application Note AND8247.
- Secondary Side Bias Supply for Isolated dc-dc Converters
- Stand Alone Low Power dc-dc Converter
- Low Power Bias Supply
- Low Power Boost Converter



A = Assembly Location  
L = Wafer Lot  
Y = Year  
W = Work Week  
▪ = Pb-Free Package

(Note: Microdot may be in either location)

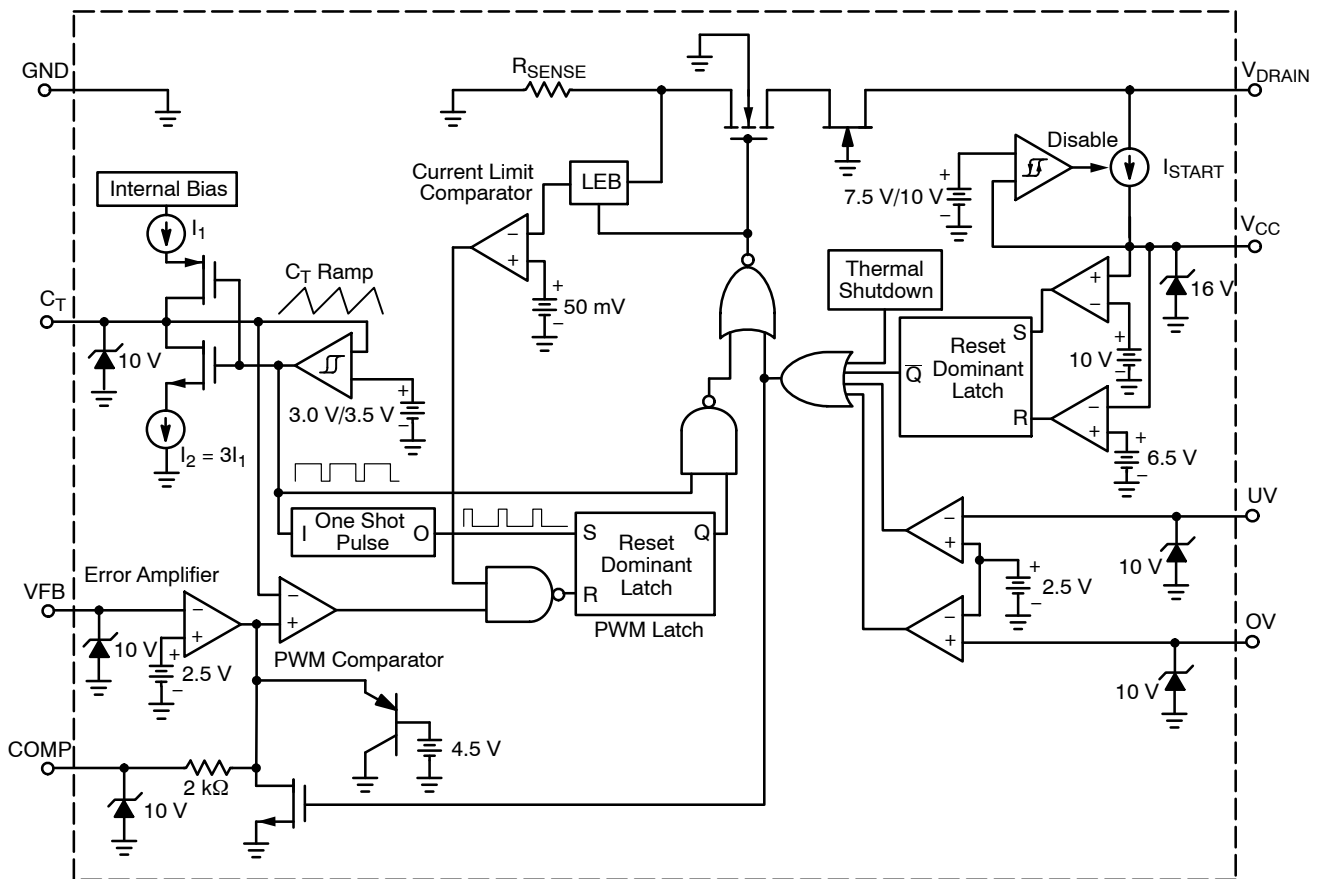
### PIN CONNECTIONS



### ORDERING INFORMATION

See detailed ordering and shipping information in the package dimensions section on page 19 of this data sheet.

# NCP1030, NCP1031

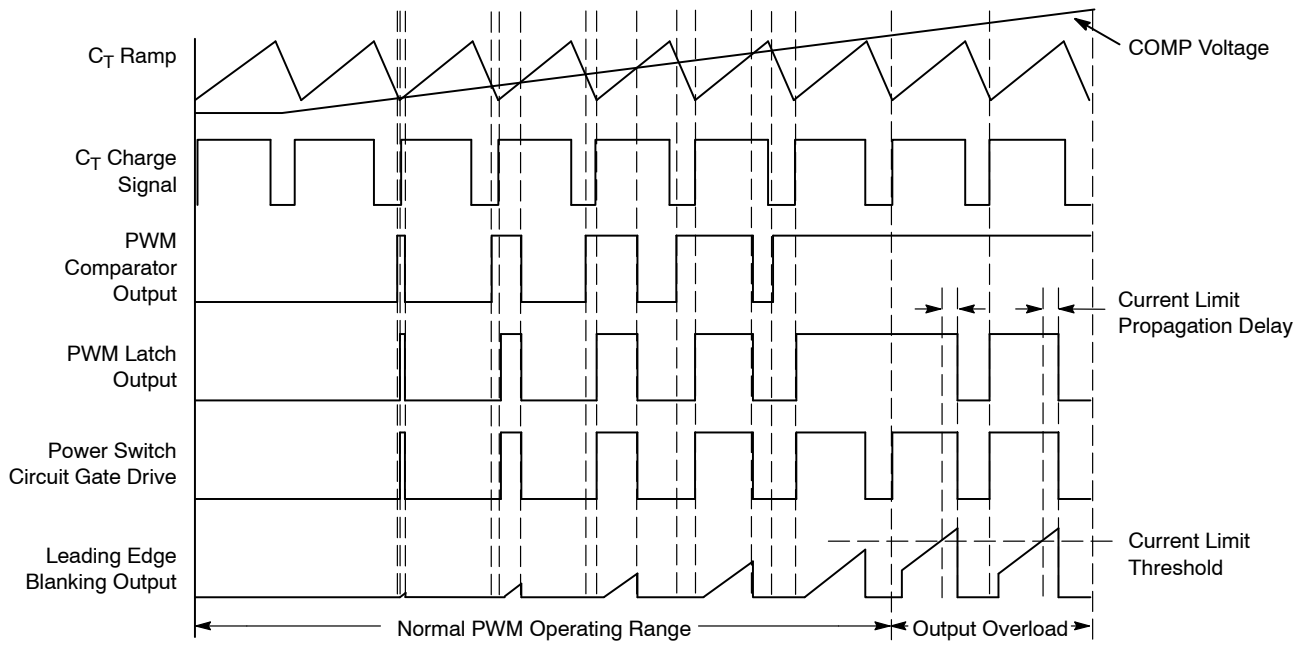


**Figure 1. NCP1030/31 Functional Block Diagram**

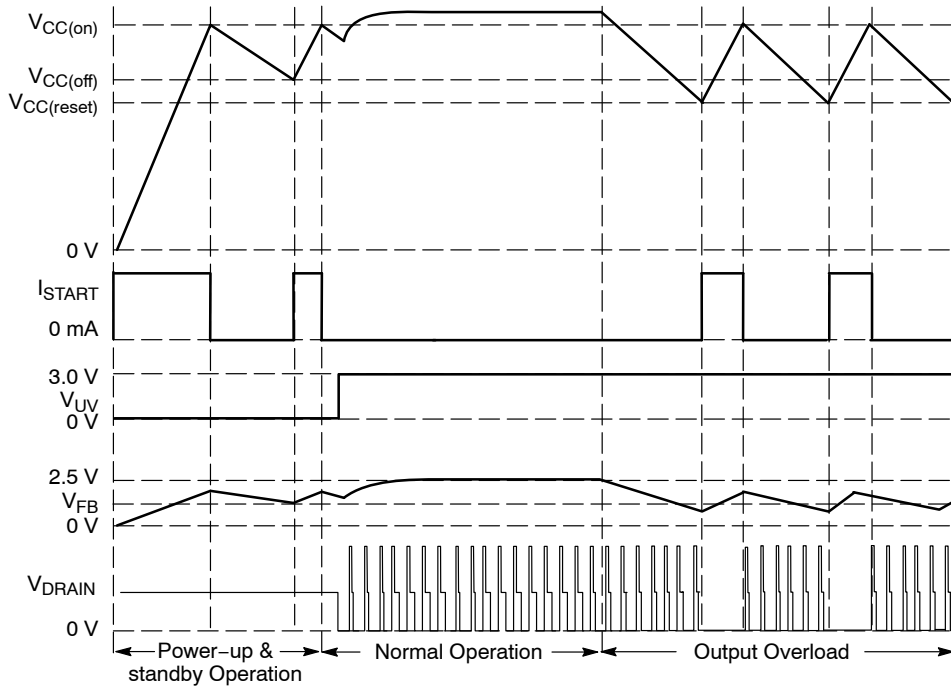
## FUNCTIONAL PIN DESCRIPTION

Pin	Name	Function	Description
1	GND	Ground	Ground reference pin for the circuit.
2	C <sub>T</sub>	Oscillator Frequency Selection	An external capacitor connected to this pin sets the oscillator frequency up to 1 MHz. The oscillator can be synchronized to a higher frequency by charging or discharging C <sub>T</sub> to trip the internal 3.0 V/3.5 V comparator. If a fault condition exists, the power switch is disabled and the frequency is reduced by a factor of 7.
3	V <sub>FB</sub>	Feedback Input	The regulated voltage is scaled down to 2.5 V by means of a resistor divider. Regulation is achieved by comparing the scaled voltage to an internal 2.5 V reference.
4	COMP	Error Amplifier Compensation	Requires external compensation network between COMP and V <sub>FB</sub> pins. This pin is effectively grounded if faults are present.
5	OV	Line Overvoltage Shutdown	Line voltage (V <sub>in</sub> ) is scaled down using an external resistor divider such that the OV voltage reaches 2.5 V when line voltage reaches its maximum operating voltage.
6	UV	Line Undervoltage Shutdown	Line voltage is scaled down using an external resistor divider such that the UV voltage reaches 2.5 V when line voltage reaches its minimum operating voltage.
7	V <sub>CC</sub>	Supply Voltage	This pin is connected to an external capacitor for energy storage. During Turn-On, the startup circuit sources current to charge the capacitor connected to this pin. When the supply voltage reaches V <sub>CC(on)</sub> , the startup circuit turns OFF and the power switch is enabled if no faults are present. An external winding is used to supply power after initial startup to reduce power dissipation. V <sub>CC</sub> should not exceed 16 V.
8	V <sub>DRAIN</sub>	Power Switch and Startup Circuits	This pin directly connects the Power Switch and Startup Circuits to one of the transformer windings. The internal High Voltage Power Switch Circuit is connected between this pin and ground. V <sub>DRAIN</sub> should not exceed 200 V.

# NCP1030, NCP1031



**Figure 2. Pulse Width Modulation Timing Diagram**



**Figure 3. Auxiliary Winding Operation with Output Overload Timing Diagram**

# NCP1030, NCP1031

## MAXIMUM RATINGS

Rating	Symbol	Value	Unit
Power Switch and Startup Circuits Voltage	$V_{DRAIN}$	-0.3 to 200	V
Power Switch and Startup Circuits Input Current – NCP1030 – NCP1031	$I_{DRAIN}$	1.0 2.0	A
$V_{CC}$ Voltage Range	$V_{CC}$	-0.3 to 16	V
All Other Inputs/Outputs Voltage Range	$V_{IO}$	-0.3 to 10	V
$V_{CC}$ and All Other Inputs/Outputs Current	$I_{IO}$	100	mA
Operating Junction Temperature	$T_J$	-40 to 150	°C
Storage Temperature	$T_{stg}$	-55 to 150	°C
Power Dissipation ( $T_J = 25^\circ\text{C}$ , 2.0 Oz., 1.0 Sq Inch Printed Circuit Copper Clad) DM Suffix, Plastic Package Case 846A D Suffix, Plastic Package Case 751 MN Suffix, Plastic Package Case 488AF		0.582 0.893 1.453	W
Thermal Resistance, Junction to Air (2.0 Oz., 1.0 Sq Inch Printed Circuit Copper Clad) DM Suffix, Plastic Package Case 846A D Suffix, Plastic Package Case 751 MN Suffix, Plastic Package Case 488AF	$R_{\theta JA}$	172 112 69	°C/W

Stresses exceeding those listed in the Maximum Ratings table may damage the device. If any of these limits are exceeded, device functionality should not be assumed, damage may occur and reliability may be affected.

A. This device contains ESD protection circuitry and exceeds the following tests:

Pins 1–7: Human Body Model 2000V per MIL–STD–883, Method 3015.

Machine Model Method 200 V.

Pin 8 is connected to the High Voltage Startup and Power Switch Circuits and rated only to the maximum voltage rating of the part, or 200 V.

B. This device contains Latchup protection and exceeds  $\pm 100$  mA per JEDEC Standard JESD78.

# NCP1030, NCP1031

**DC ELECTRICAL CHARACTERISTICS** ( $V_{DRAIN} = 48\text{ V}$ ,  $V_{CC} = 12\text{ V}$ ,  $C_T = 560\text{ pF}$ ,  $V_{UV} = 3\text{ V}$ ,  $V_{OV} = 2\text{ V}$ ,  $V_{FB} = 2.3\text{ V}$ ,  $V_{COMP} = 2.5\text{ V}$ ,  $T_J = -40^\circ\text{C}$  to  $125^\circ\text{C}$ , typical values shown are for  $T_J = 25^\circ\text{C}$  unless otherwise noted.) (Note 1)

Characteristics	Symbol	Min	Typ	Max	Unit
<b>STARTUP CONTROL</b>					
Startup Circuit Output Current ( $V_{FB} = V_{COMP}$ ) <b>NCP1030</b> $T_J = 25^\circ\text{C}$ $V_{CC} = 0\text{ V}$ $V_{CC} = V_{CC(on)} - 0.2\text{ V}$ $T_J = -40^\circ\text{C}$ to $125^\circ\text{C}$ $V_{CC} = 0\text{ V}$ $V_{CC} = V_{CC(on)} - 0.2\text{ V}$ <b>NCP1031</b> $T_J = 25^\circ\text{C}$ $V_{CC} = 0\text{ V}$ $V_{CC} = V_{CC(on)} - 0.2\text{ V}$ $T_J = -40^\circ\text{C}$ to $125^\circ\text{C}$ $V_{CC} = 0\text{ V}$ $V_{CC} = V_{CC(on)} - 0.2\text{ V}$	$I_{START}$	10 6.0	12.5 8.6	15 12	mA
$V_{CC}$ Supply Monitor ( $V_{FB} = 2.7\text{ V}$ ) Startup Threshold Voltage ( $V_{CC}$ Increasing) Minimum Operating $V_{CC}$ After Turn-on ( $V_{CC}$ Increasing) Hysteresis Voltage	$V_{CC(on)}$ $V_{CC(off)}$ $V_{CC(hys)}$	9.6 7.0 –	10.2 7.6 2.6	10.6 8.0 –	V
Undervoltage Lockout Threshold Voltage, $V_{CC}$ Decreasing ( $V_{FB} = V_{COMP}$ )	$V_{CC(reset)}$	6.0	6.6	7.0	V
Minimum Startup Voltage (Pin 8) $I_{START} = 0.5\text{ mA}$ , $V_{CC} = V_{CC(on)} - 0.2\text{ V}$	$V_{START(min)}$	–	16.8	18.5	V

## ERROR AMPLIFIER

Reference Voltage ( $V_{COMP} = V_{FB}$ , Follower Mode) $T_J = 25^\circ\text{C}$ $T_J = -40^\circ\text{C}$ to $125^\circ\text{C}$	$V_{REF}$	2.45 2.40	2.5 2.5	2.55 2.60	V
Line Regulation ( $V_{CC} = 8\text{ V}$ to $16\text{ V}$ , $T_J = 25^\circ\text{C}$ )	$REG_{LINE}$	–	1.0	5.0	mV
Input Bias Current ( $V_{FB} = 2.3\text{ V}$ )	$I_{VFB}$	–	0.1	1.0	$\mu\text{A}$
COMP Source Current	$I_{SRC}$	80	110	140	$\mu\text{A}$
COMP Sink Current ( $V_{FB} = 2.7\text{ V}$ )	$I_{SNK}$	200	550	900	$\mu\text{A}$
COMP Maximum Voltage ( $I_{SRC} = 0\text{ }\mu\text{A}$ )	$V_{C(max)}$	4.5	–	–	V
COMP Minimum Voltage ( $I_{SNK} = 0\text{ }\mu\text{A}$ , $V_{FB} = 2.7\text{ V}$ )	$V_{C(min)}$	–	–	1.0	V
Open Loop Voltage Gain	$A_{VOL}$	–	80	–	dB
Gain Bandwidth Product	GBW	–	1.0	–	MHz

## LINE UNDER/OVERVOLTAGE DETECTOR

Undervoltage Lockout ( $V_{FB} = V_{COMP}$ ) Voltage Threshold ( $V_{in}$ Increasing) Voltage Hysteresis Input Bias Current	$V_{UV}$ $V_{UV(hys)}$ $I_{UV}$	2.400 0.075 –	2.550 0.175 0	2.700 0.275 1.0	V V $\mu\text{A}$
Overvoltage Lockout ( $V_{FB} = V_{COMP}$ ) Voltage Threshold ( $V_{in}$ Increasing) Voltage Hysteresis Input Bias Current	$V_{OV}$ $V_{OV(hys)}$ $I_{OV}$	2.400 0.075 –	2.550 0.175 0	2.700 0.275 1.0	V V $\mu\text{A}$

Product parametric performance is indicated in the Electrical Characteristics for the listed test conditions, unless otherwise noted. Product performance may not be indicated by the Electrical Characteristics if operated under different conditions.

1. Production testing for NCP1030DMR2 is performed at  $25^\circ\text{C}$  only; limits at  $-40^\circ\text{C}$  and  $125^\circ\text{C}$  are guaranteed by design.

# NCP1030, NCP1031

**DC ELECTRICAL CHARACTERISTICS** ( $V_{DRAIN} = 48\text{ V}$ ,  $V_{CC} = 12\text{ V}$ ,  $C_T = 560\text{ pF}$ ,  $V_{UV} = 3\text{ V}$ ,  $V_{OV} = 2\text{ V}$ ,  $V_{FB} = 2.3\text{ V}$ ,  $V_{COMP} = 2.5\text{ V}$ ,  $T_J = -40^\circ\text{C}$  to  $125^\circ\text{C}$ , typical values shown are for  $T_J = 25^\circ\text{C}$  unless otherwise noted.) (Note 2)

Characteristics	Symbol	Min	Typ	Max	Unit
-----------------	--------	-----	-----	-----	------

## OSCILLATOR

Frequency ( $C_T = 560\text{ pF}$ , Note 3) $T_J = 25^\circ\text{C}$ $T_J = -40^\circ\text{C}$ to $125^\circ\text{C}$	$f_{OSC1}$	275 260	300 –	325 325	kHz
Frequency ( $C_T = 100\text{ pF}$ )	$f_{OSC2}$	–	800	–	kHz
Charge Current ( $V_{CT} = 3.25\text{ V}$ )	$I_{CT(C)}$	–	215	–	$\mu\text{A}$
Discharge Current ( $V_{CT} = 3.25\text{ V}$ )	$I_{CT(D)}$	–	645	–	$\mu\text{A}$
Oscillator Ramp Peak Valley	$V_{rpk}$ $V_{rly}$	– –	3.5 3.0	– –	V

## PWM COMPARATOR

Maximum Duty Cycle	$DC_{MAX}$	70	75	80	%
--------------------	------------	----	----	----	---

## POWER SWITCH CIRCUIT

Power Switch Circuit On-State Resistance ( $I_D = 100\text{ mA}$ ) NCP1030 $T_J = 25^\circ\text{C}$ $T_J = 125^\circ\text{C}$ NCP1031 $T_J = 25^\circ\text{C}$ $T_J = 125^\circ\text{C}$	$R_{DS(on)}$	– – – –	4.1 6.0 2.1 3.5	7.0 12 3.0 6.0	$\Omega$
Power Switch Circuit and Startup Circuit Breakdown Voltage ( $I_D = 100\text{ }\mu\text{A}$ , $T_J = 25^\circ\text{C}$ )	$V_{(BR)DS}$	200	–	–	V
Power Switch Circuit and Startup Circuit Off-State Leakage Current ( $V_{DRAIN} = 200\text{ V}$ , $V_{UV} = 2.0\text{ V}$ ) $T_J = 25^\circ\text{C}$ $T_J = -40$ to $125^\circ\text{C}$	$I_{DS(off)}$	– –	13 –	25 50	$\mu\text{A}$
Switching Characteristics ( $V_{DS} = 48\text{ V}$ , $R_L = 100\text{ }\Omega$ ) Rise Time Fall Time	$t_r$ $t_f$	– –	22 24	– –	ns

## CURRENT LIMIT AND OVER TEMPERATURE PROTECTION

Current Limit Threshold ( $T_J = 25^\circ\text{C}$ ) NCP1030 ( $di/dt = 0.5\text{ A}/\mu\text{s}$ ) NCP1031 ( $di/dt = 1.0\text{ A}/\mu\text{s}$ )	$I_{LIM}$	350 700	515 1050	680 1360	mA
Propagation Delay, Current Limit Threshold to Power Switch Circuit Output (Leading Edge Blanking plus Current Limit Delay)	$t_{PLH}$	–	100	–	ns
Thermal Protection (Note 4) Shutdown Threshold ( $T_J$ Increasing) Hysteresis	$T_{SHDN}$ $T_{HYS}$	– –	150 45	– –	$^\circ\text{C}$

## TOTAL DEVICE

Supply Current After UV Turn-On Power Switch Enabled Power Switch Disabled Non-Fault condition ( $V_{FB} = 2.7\text{ V}$ ) Fault Condition ( $V_{FB} = 2.7\text{ V}$ , $V_{UV} = 2.0\text{ V}$ )	$I_{CC1}$  $I_{CC2}$ $I_{CC3}$	2.0 – –	3.0 1.5 0.65	4.0 2.0 1.2	mA
--	---	---------------	--------------------	-------------------	----

2. Production testing for NCP1030DMR2 is performed at  $25^\circ\text{C}$  only; limits at  $-40^\circ\text{C}$  and  $125^\circ\text{C}$  are guaranteed by design.
3. Oscillator frequency can be externally synchronized to the maximum frequency of the device.
4. Guaranteed by design only.

# NCP1030, NCP1031

## TYPICAL CHARACTERISTICS

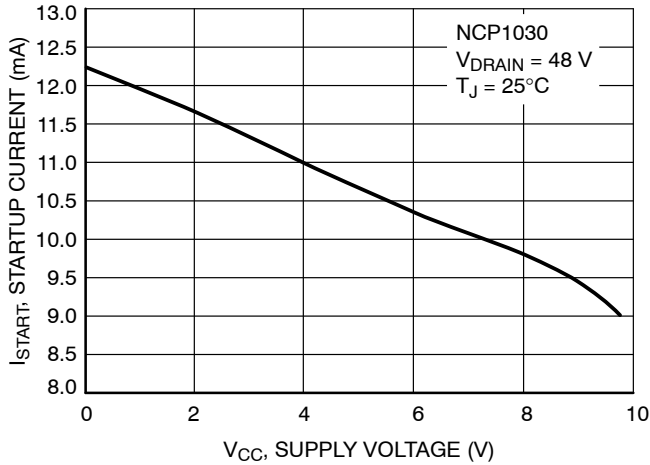


Figure 4. NCP1030 Startup Current vs. Supply Voltage

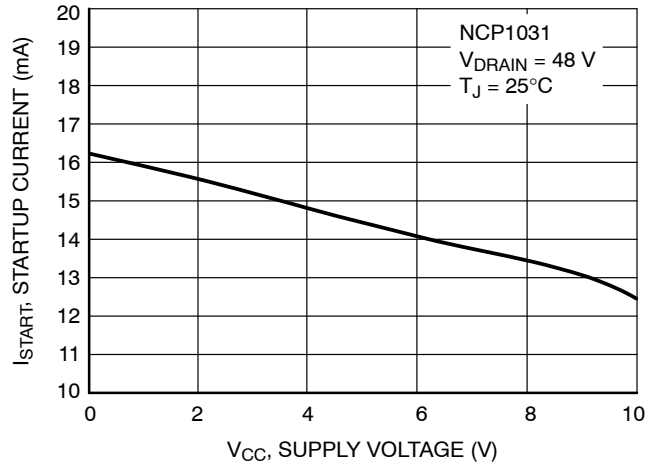


Figure 5. NCP1031 Startup Current vs. Supply Voltage

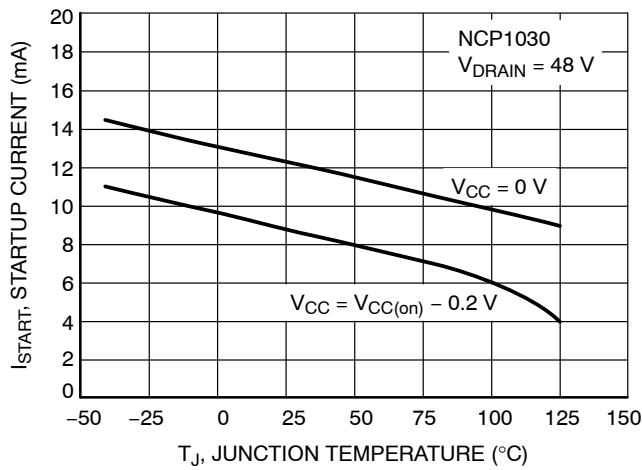


Figure 6. NCP1030 Startup Current vs. Junction Temperature

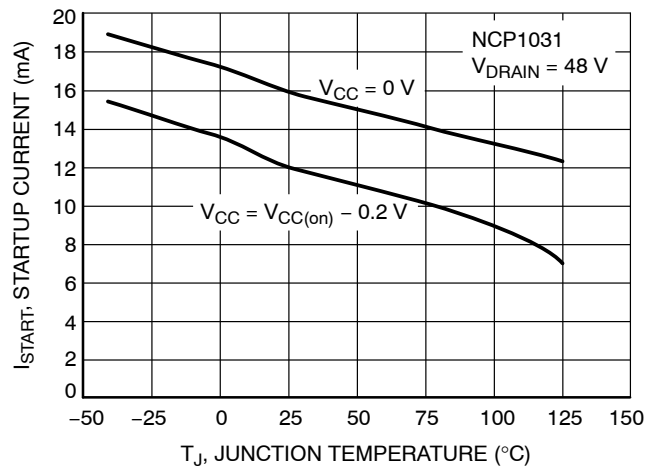


Figure 7. NCP1031 Startup Current vs. Junction Temperature

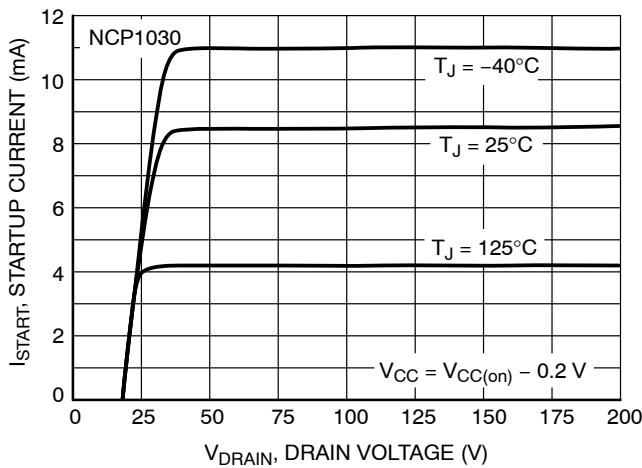


Figure 8. NCP1030 Startup Current vs. Drain Voltage

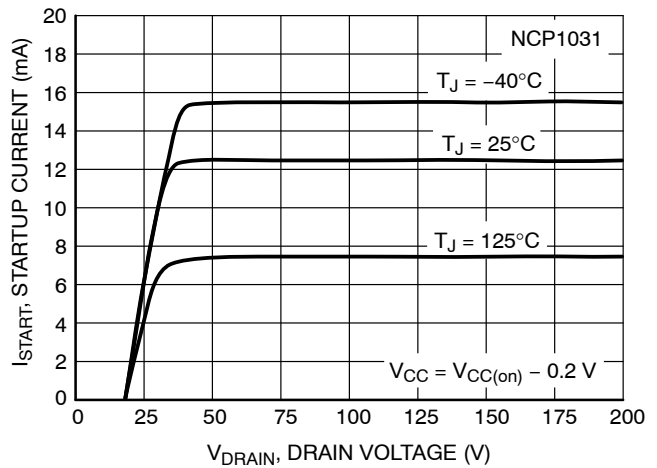


Figure 9. NCP1031 Startup Current vs. Drain Voltage

# NCP1030, NCP1031

## TYPICAL CHARACTERISTICS

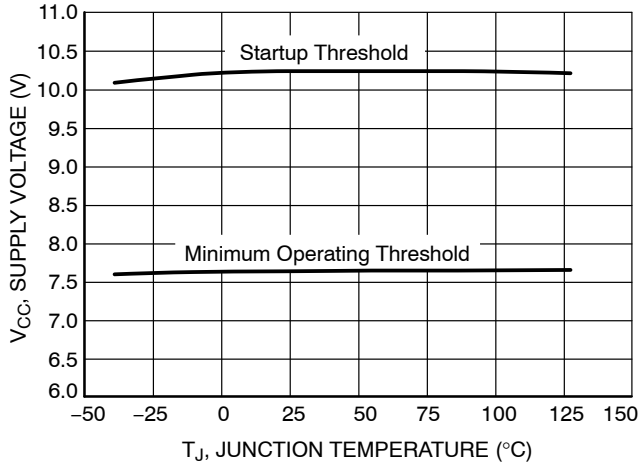


Figure 10. Supply Voltage Thresholds vs. Junction Temperature

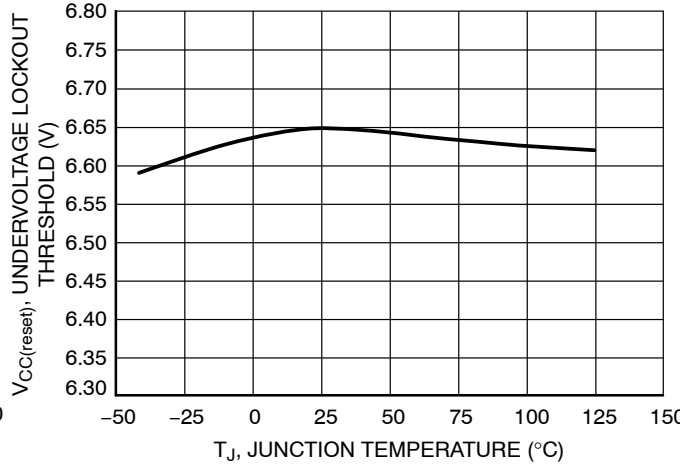


Figure 11. Undervoltage Lockout Threshold vs. Junction Temperature

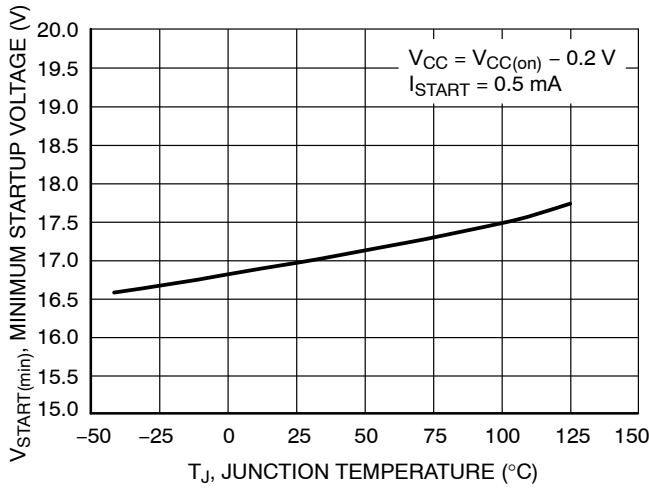


Figure 12. Minimum Startup Voltage vs. Junction Temperature

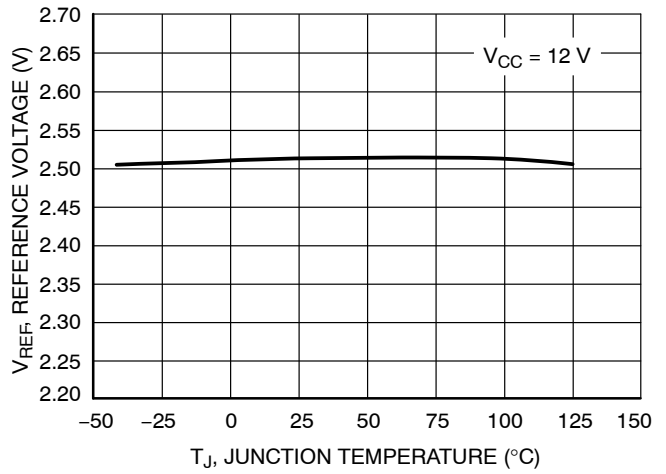


Figure 13. Reference Voltage vs. Junction Temperature

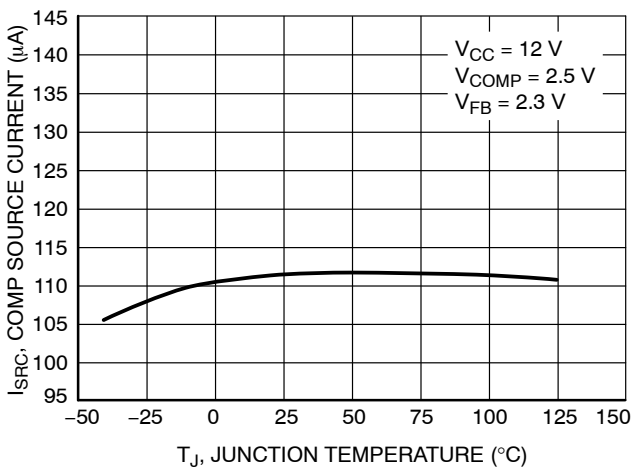


Figure 14. COMP Source Current vs. Junction Temperature

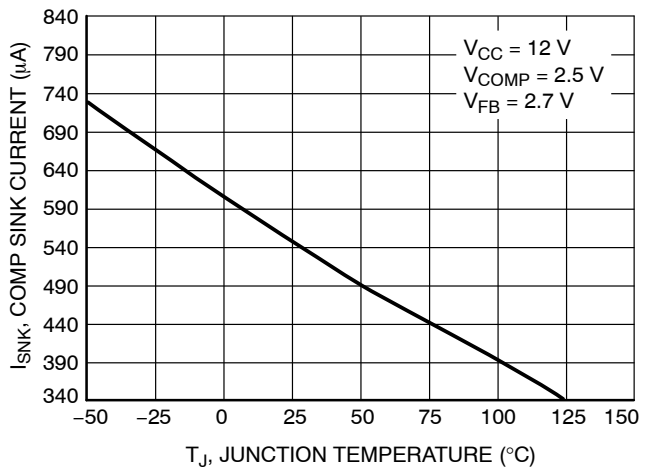
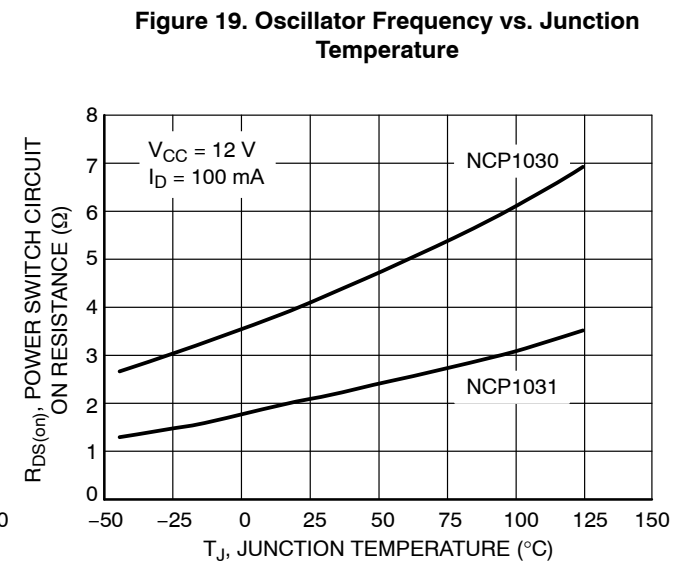
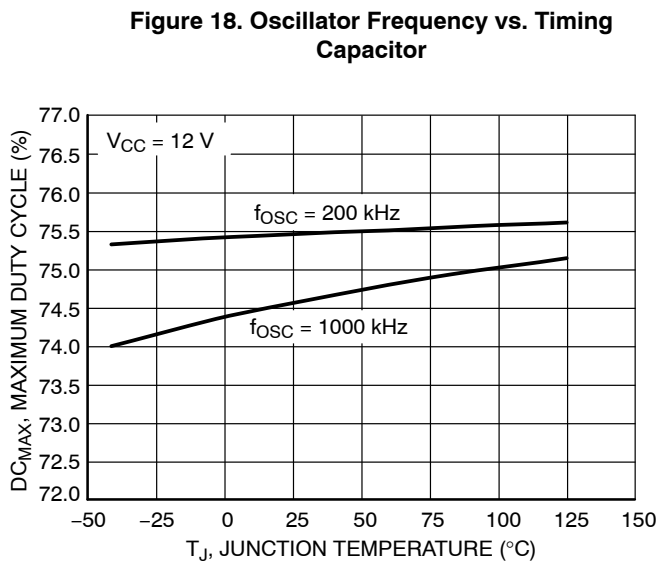
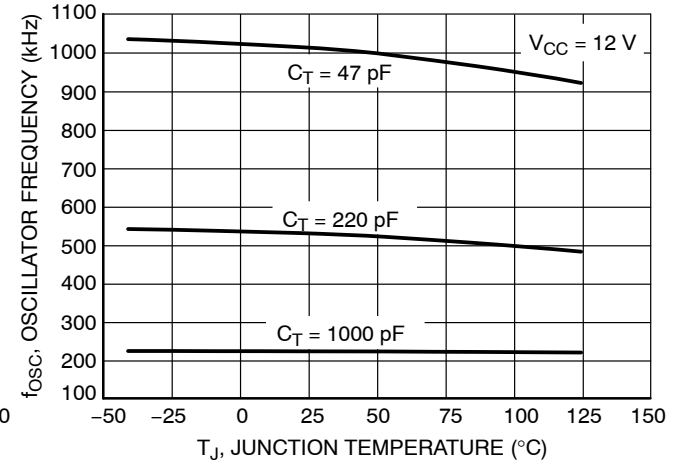
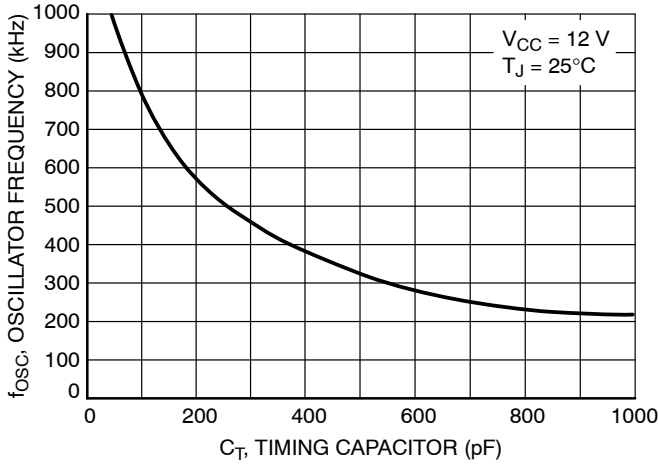
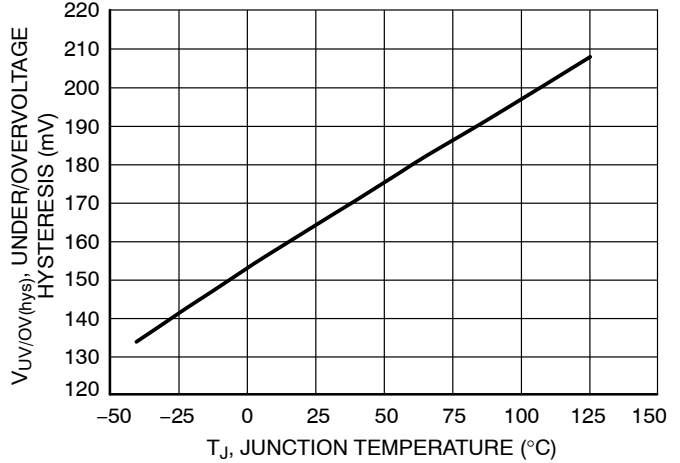
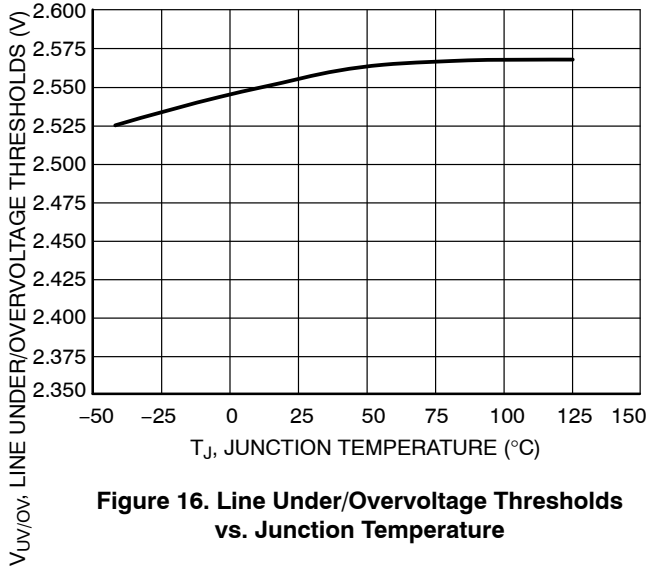


Figure 15. COMP Sink Current vs. Junction Temperature



# NCP1030, NCP1031

## TYPICAL CHARACTERISTICS

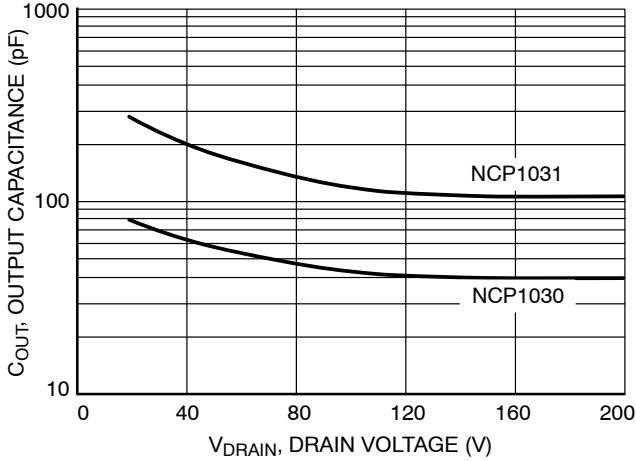


**Figure 20. Maximum Duty Cycle vs. Junction Temperature**

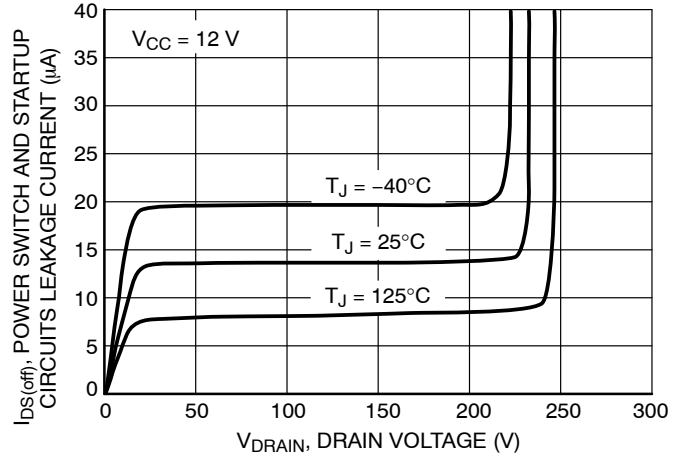
**Figure 21. Power Switch Circuit On Resistance vs. Junction Temperature**

# NCP1030, NCP1031

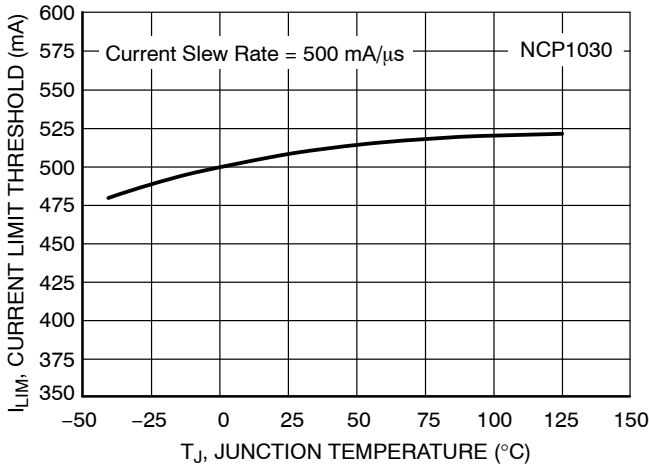
## TYPICAL CHARACTERISTICS



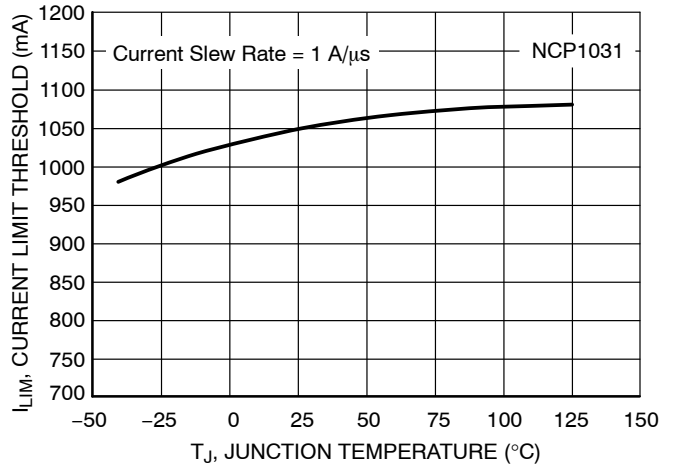
**Figure 22. Power Switch Circuit Output Capacitance vs. Drain Voltage**



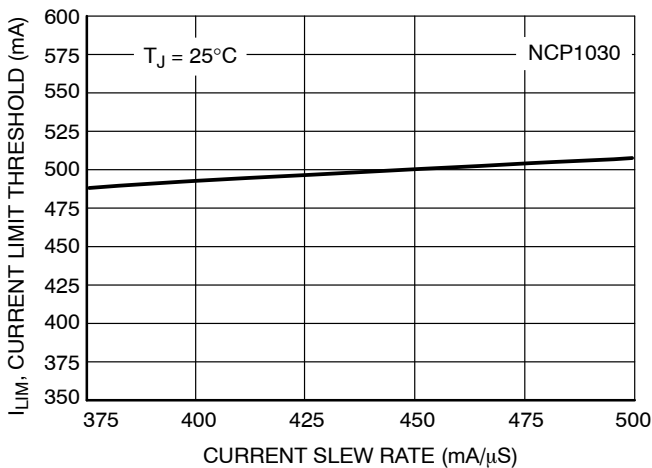
**Figure 23. Power Switch Circuit and Startup Circuit Leakage Current vs. Drain Voltage**



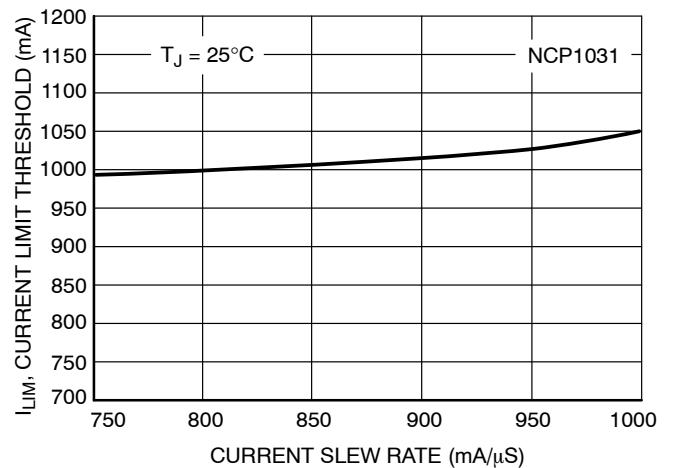
**Figure 24. NCP1030 Current Limit Threshold vs. Junction Temperature**



**Figure 25. NCP1031 Current Limit Threshold vs. Junction Temperature**



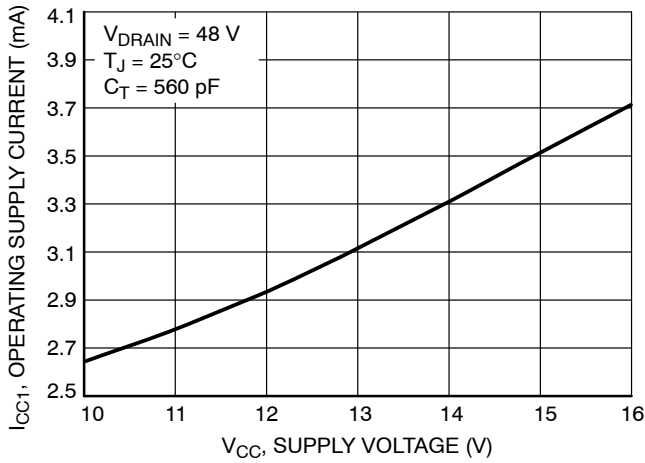
**Figure 26. NCP1030 Current Limit Threshold vs. Current Slew Rate**



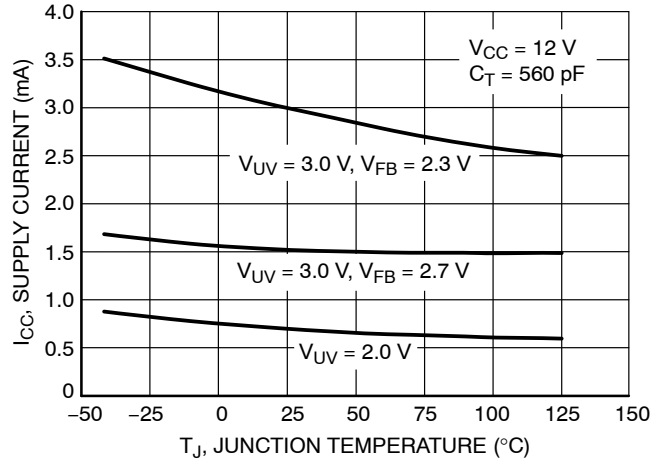
**Figure 27. NCP1031 Current Limit Threshold vs. Current Slew Rate**

# NCP1030, NCP1031

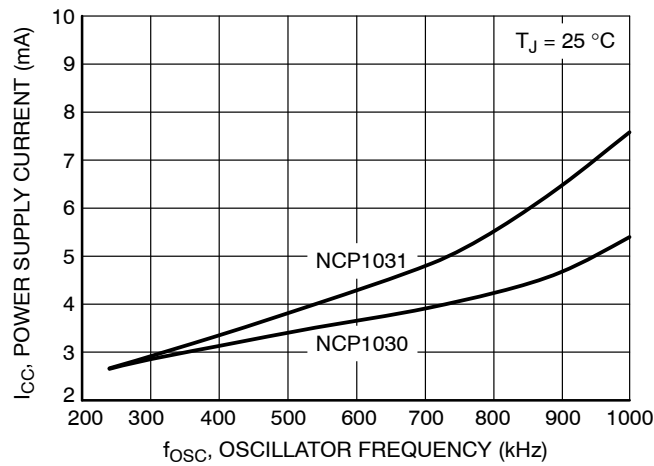
## TYPICAL CHARACTERISTICS



**Figure 28. Operating Supply Current vs. Supply Voltage**

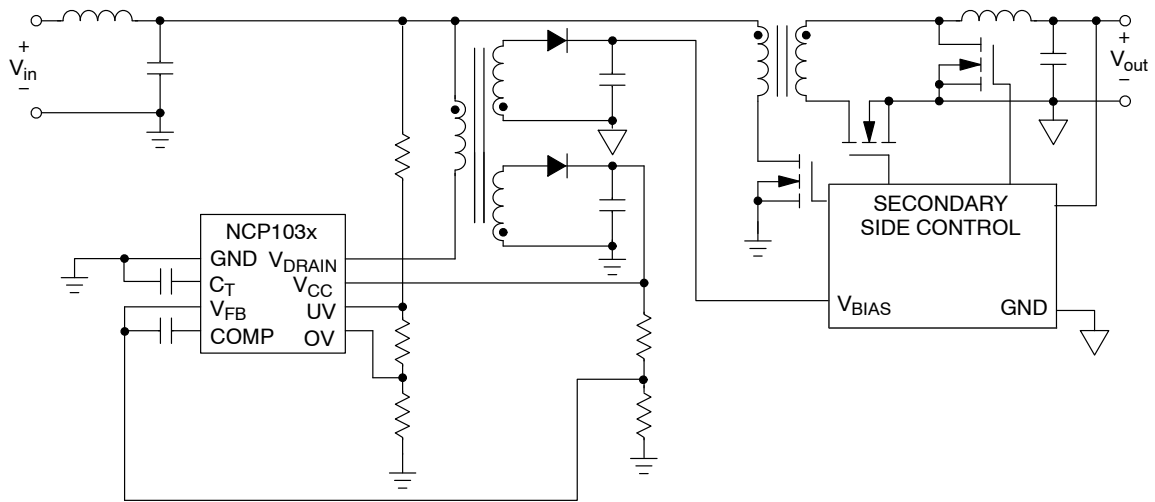


**Figure 29. Supply Current vs. Junction Temperature**

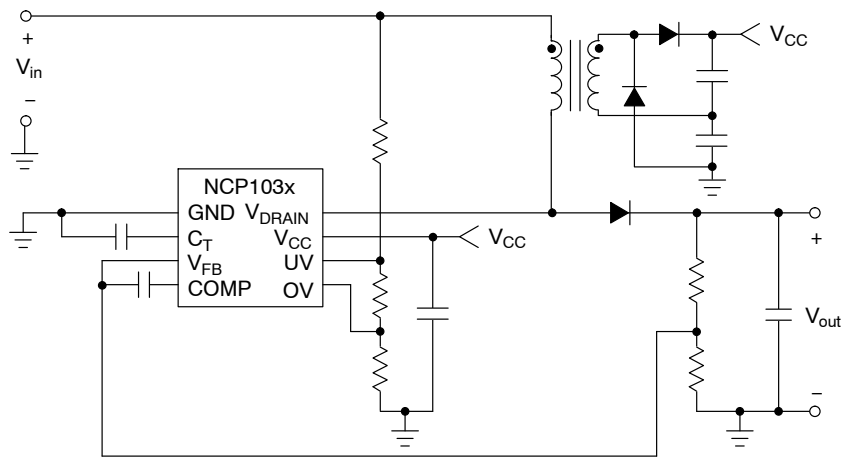


**Figure 30. Operating Supply Current vs. Oscillator Frequency**

## NCP1030, NCP1031



**Figure 31. Secondary Side Bias Supply Configuration**



**Figure 32. Boost Circuit Configuration**

## OPERATING DESCRIPTION

### Introduction

The NCP1030 and NCP1031 are a family of miniature monolithic voltage-mode switching regulators designed for isolated and non-isolated bias supply applications. The internal startup circuit and the MOSFET are rated at 200 V, making them ideal for 48 V telecom and 42 V automotive applications. In addition, the NCP103x family can operate from an existing 12 V supply. This controller family is optimized for operation up to 1 MHz.

The NCP103x family incorporates in a single IC all the active power, control logic and protection circuitry required to implement, with a minimum of external components, several switching regulator applications, such as a secondary side bias supply or a low power dc-dc converter.

The NCP1030 is available in the space saving Micro8™ package and is targeted for applications requiring up to 3 W. The NCP1031 is targeted for applications up to 6 W and is available in the SO-8 package.

The NCP103x includes an extensive set of features including over temperature protection, cycle by cycle current limit, individual line under and overvoltage detection comparators with hysteresis, and regulator output undervoltage lockout with hysteresis, providing full protection during fault conditions. A description of each of the functional blocks is given below, and the representative block diagram is shown in Figure 2.

### Startup Circuit and Undervoltage Lockout

The NCP103x contains an internal 200 V startup regulator that eliminates the need for external startup components. The startup regulator consists of a constant current source that supplies current from the input line ( $V_{in}$ ) to the capacitor on the  $V_{CC}$  pin ( $C_{CC}$ ). Once the  $V_{CC}$  voltage reaches approximately 10 V, the startup circuit is disabled and the Power Switch Circuit is enabled if no faults are present. During this self-bias mode, power to the NCP103x is supplied by the  $V_{CC}$  capacitor. The startup regulator turns ON again once  $V_{CC}$  reaches 7.5 V. This “7.5–10” mode of operation is known as Dynamic Self Supply (DSS). The NCP1030 and NCP1031 startup currents are 12 mA and 16 mA, respectively.

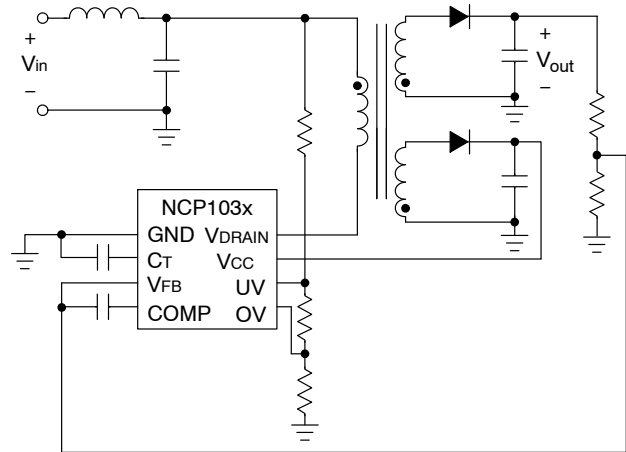
If  $V_{CC}$  falls below 7.5 V, the device enters a re-start mode. While in the re-start mode, the  $V_{CC}$  capacitor is allowed to discharge to 6.5 V while the Power Switch is enabled. Once the 6.5 V threshold is reached, the Power Switch Circuit is disabled and the startup regulator is enabled to charge the  $V_{CC}$  capacitor. The Power Switch is enabled again once the  $V_{CC}$  voltage reaches 10 V. Therefore, the external  $V_{CC}$  capacitor must be sized such that a voltage greater than 7.5 V is maintained on the  $V_{CC}$  capacitor while the converter output reaches regulation. Otherwise, the converter will enter the re-start mode. Equation (1) provides a guideline for the selection of the  $V_{CC}$  capacitor for a forward converter;

Forward:

$$C_{CC} = \frac{\cos^{-1} \left( 1 - \frac{V_{OUT} \cdot N_P}{DC \cdot V_{in} \cdot N_S} \right) \times \sqrt{L_{OUT} C_{OUT}} \cdot I_{bias}}{2.6} \quad (\text{eq. 1})$$

where,  $I_{bias}$  is the bias current supplied by the  $V_{CC}$  capacitor including the IC bias current ( $I_{CC1}$ ) and any additional current used to bias the feedback resistors (if used).

After initial startup, the  $V_{CC}$  pin should be biased above  $V_{CC(off)}$  using an auxiliary winding. This will prevent the startup regulator from turning ON and reduce power dissipation. Also, the load should not be directly connected to the  $V_{CC}$  capacitor. Otherwise, the load may override the startup circuit. Figure 33 shows the recommended configuration for a non-isolated flyback converter.



**Figure 33. Non-Isolated Bias Supply Configuration**

The maximum voltage rating of the startup circuit is 200 V. Power dissipation should be observed to avoid exceeding the maximum power dissipation of the package.

### Error Amplifier

The internal error amplifier (EA) regulates the output voltage of the bias supply. It compares a scaled output voltage signal to an internal 2.5 V reference ( $V_{REF}$ ) connected to its non-inverting input. The scaled signal is fed into the feedback pin ( $V_{FB}$ ) which is the inverting input of the error amplifier.

The output of the error amplifier is available for frequency compensation and connection to the PWM comparator through the COMP pin. To insure normal operation, the EA compensation should be selected such that the EA frequency response crosses 0 dB below 80 kHz.

The error amplifier input bias current is less than 1  $\mu$ A over the operating range. The output source and sink currents are typically 110  $\mu$ A and 550  $\mu$ A, respectively.

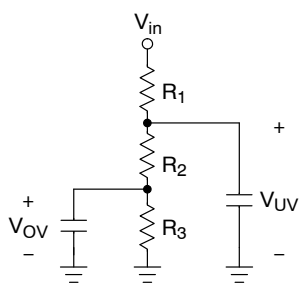
Under load transient conditions, COMP may need to move from the bottom to the top of the  $C_T$  Ramp. A large current is required to complete the COMP swing if small resistors or large capacitors are used to implement the compensation network. In which case, the COMP swing will

be limited by the EA sink current, typically 110  $\mu\text{A}$ . Optimum transient response is obtained if the compensation components allow COMP to swing across its operating range in 1 cycle.

**Line Under and Overvoltage Detector**

The NCP103x incorporates individual line undervoltage (UV) and overvoltage (OV) shutdown circuits. The UV and OV thresholds are 2.5 V. A fault is present if the UV is below 2.5 V or if the OV voltage is above 2.5 V. The UV/OV detectors incorporate 175 mV hysteresis to prevent noise from triggering the shutdown circuits.

The UV/OV circuits can be biased using an external resistor divider from the input line as shown in Figure 34. The UV/OV pins should be bypassed using a capacitor to prevent triggering the UV or OV circuits during normal switching operation.



**Figure 34. UV/OV Resistor Divider from the Input Line**

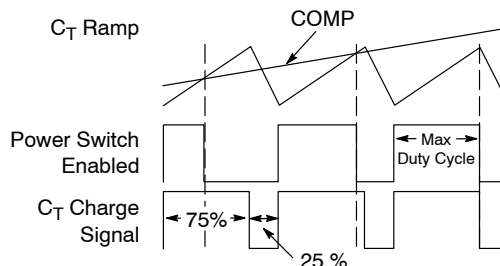
The resistor divider must be sized to enable the controller once  $V_{in}$  is within the required operating range. While a UV or OV fault is present, switching is not allowed and the COMP pin is effectively grounded.

Either of these comparators can be used for a different function if UV or OV functions are not needed. For example, the UV/OV detectors can be used to implement an enable or disable function. If positive logic is used, the enable signal is applied to the UV pin while the OV pin is grounded. If negative logic is used, the disable signal is applied to the OV pin while biasing the UV pin from  $V_{CC}$  using a resistor divider.

**Oscillator**

The oscillator is optimized for operation up to 1 MHz and its frequency is set by the external timing capacitor ( $C_T$ ) connected to the  $C_T$  pin. The oscillator has two modes of operation, free running and synchronized (sync). While in free running mode, an internal current source sequentially charges and discharges  $C_T$  generating a voltage ramp between 3.0 V and 3.5 V. Under normal operating conditions, the charge ( $I_{CT(C)}$ ) and discharge ( $I_{CT(D)}$ ) currents are typically 215  $\mu\text{A}$  and 645  $\mu\text{A}$ , respectively. The charge:discharge current ratio of 1:3 discharges  $C_T$  in 25 % of the total period. The Power Switch is disabled while  $C_T$

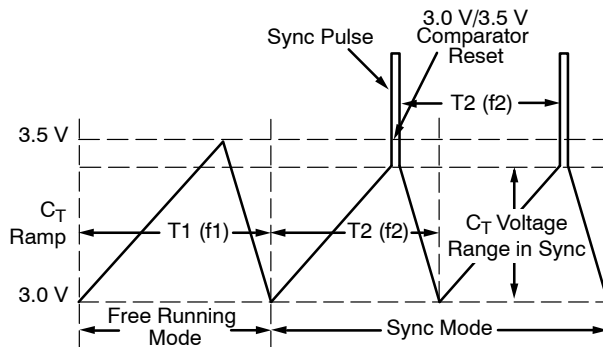
is discharging, guaranteeing a maximum duty cycle of 75 % as shown in Figure 35.



**Figure 35. Maximum Duty Cycle vs COMP**

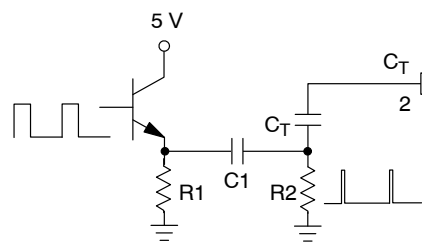
Figure 18 shows the relationship between the operating frequency and  $C_T$ . If an UV fault is present, both  $I_{CT(C)}$  and  $I_{CT(D)}$  are reduced by a factor of 7, thus reducing the operating frequency by the same factor.

The oscillator can be synchronized to a higher frequency by capacitively coupling a synchronization pulse into the  $C_T$  pin. In sync mode, the voltage on the  $C_T$  pin needs to be driven above 3.5 V to trigger the internal comparator and complete the  $C_T$  charging period. However, pulsing the  $C_T$  pin before it reaches 3.5 V will reduce the p-p amplitude of the  $C_T$  Ramp as shown in Figure 36.



**Figure 36. External Frequency Synchronization Waveforms**

The oscillator frequency should be set no more that 25% below the target sync frequency to maintain an adequate voltage range and provide good noise immunity. A possible circuit to synchronize the oscillator is shown in Figure 37.



**Figure 37. External Frequency Synchronization Circuit.**

## PWM Comparator and Latch

The Pulse Width Modulator (PWM) Comparator compares the error amplifier output (COMP) to the  $C_T$  Ramp and generates a proportional duty cycle. The Power Switch is enabled while the  $C_T$  Ramp is below COMP as shown in Figure 35. Once the  $C_T$  Ramp reaches COMP, the Power Switch is disabled. If COMP is at the bottom of the  $C_T$  Ramp, the converter operates at minimum duty cycle. While COMP increases, the duty cycle increases, until COMP reaches the peak of the  $C_T$  Ramp, at which point the controller operates at maximum duty cycle.

The  $C_T$  Charge Signal is filtered through a One Shot Pulse Generator to set the PWM Latch and enable switching at the beginning of each period. Switching is allowed while the  $C_T$  Ramp is below COMP and a current limit fault is not present.

The PWM Latch and Comparator propagation delay is typically 150 ns. If the system is designed to operate with a minimum ON time less than 150 ns, the converter will skip pulses. Skipping pulses is usually not a problem, unless operating at a frequency close to the audible range. Skipping pulses is more likely when operating at high frequencies during high line and minimum load condition.

A series resistor is included for ESD protection between the EA output and the COMP pin. Under normal operation, a 220 mV offset is observed between the  $C_T$  Ramp and the COMP crossing points. This is not a problem as the series resistor does not interact with the error amplifier transfer function.

## Current Limit Comparator and Power Switch Circuit

The NCP103x monolithically integrates a 200 V Power Switch Circuit with control logic circuitry. The Power Switch Circuit is designed to directly drive the converter transformer. The characteristics of the Power Switch Circuit are well known. Therefore, the gate drive is tailored to control switching transitions and help limit electromagnetic interference (EMI). The Power Switch Circuit is capable of switching 200 V.

The Power Switch Circuit incorporates SENSEFET™ technology to monitor the drain current. A sense voltage is generated by driving a sense element,  $R_{SENSE}$ , with a current proportional to the drain current. The sense voltage is compared to an internal reference voltage on the non-inverting input of the Current Limit Comparator. If the sense voltage exceeds the reference level, the comparator resets the PWM Latch and switching is terminated. The NCP1030 and NCP1031 drain current limit thresholds are 0.5 A and 1.0 A, respectively.

Each time the Power Switch Circuit turns ON, a narrow voltage spike appears across  $R_{SENSE}$ . The spike is due to the Power Switch Circuit gate to source capacitance, transformer interwinding capacitance, and output rectifier recovery time. This spike can cause a premature reset of the PWM Latch. A proprietary active Leading Edge Blanking (LEB) Circuit masks the current signal to prevent the voltage spike from resetting the PWM Latch. The active LEB masks the current signal until the Power Switch turn ON transition is complete. The adaptive LEB period

provides better current limit control compared to a fixed blanking period.

The current limit propagation delay time is typically 100 ns. This time is measured from when an overcurrent fault appears at the Power Switch Circuit drain, to the start of the turn-off transition. Propagation delay must be factored in the transformer design to avoid transformer saturation.

## Thermal Shutdown

Internal Thermal Shutdown circuitry is provided to protect the integrated circuit in the event the maximum junction temperature is exceeded. When activated, typically at 150°C, the Power Switch Circuit is disabled. Once the junction temperature falls below 105°C, the NCP103x is allowed to resume normal operation. This feature is provided to prevent catastrophic failures from accidental device overheating. It is not intended to be used as a substitute for proper heatsinking.

## Application Considerations

A 2 W bias supply for a 48 V telecom system was designed using the NCP1030. The bias supply generates an isolated 12 V output. The circuit schematic is shown in Figure 38. Application Note AND8119/D describes the design of the bias supply.

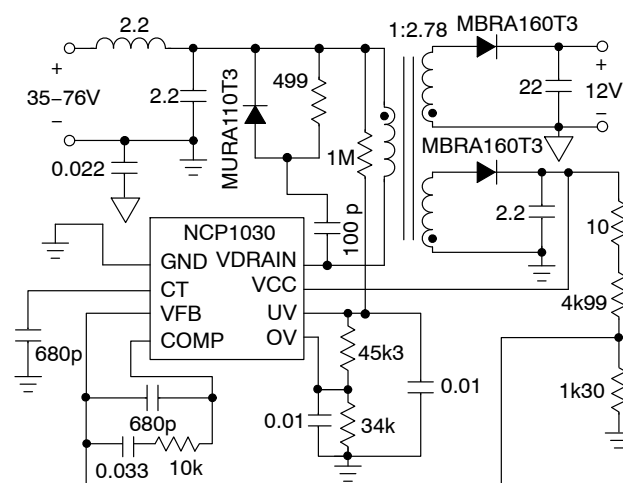


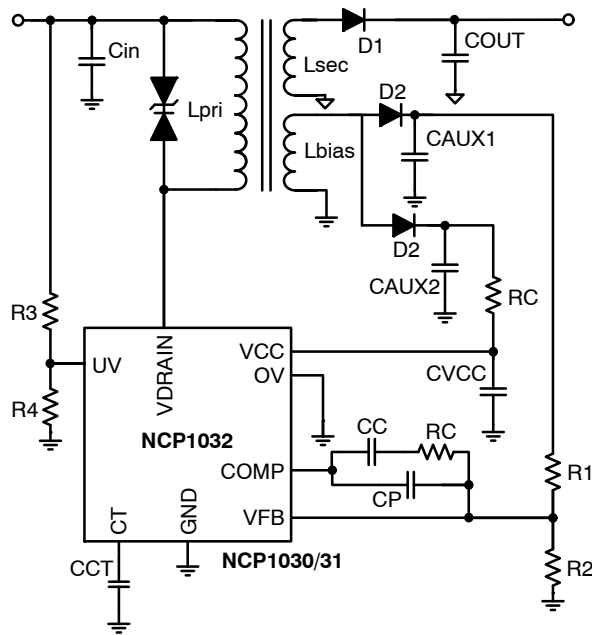
Figure 38. 2 W Isolated Bias Supply Schematic

## VCC Excursion and Compensation

Some applications may regulate nodes that are not directly connected to VCC, such as the secondary or AUX1 shown in Figure 39. The regulation of another node can result in loose regulation of VCC. The result of loose regulation is that VCC can rise to unacceptable levels when a heavy load is applied to the regulated node and a relatively light load is applied to the VCC pin. The large voltage can lead to damage of the NCP1030/31 or other downstream parts.



## NCP1030, NCP1031



**Figure 39. Typical Application with the Series Resistance Added to Control VCC**

To reduce the problem, a series resistance can be added to allow the part to clamp VCC with the characteristic current draw of the regulator as the voltage increases. The resistor value required is such that it will not impede normal operation but will prevent damage to the device during transients, startup, current limits, and over loads. The proper sizing of the series resistance starts with an examination of the current draw by the NCP1031 at the desired operating frequency as shown in Figure 40. The resistor value should be such that it does not exceed the VCC maximum voltage of 16 V during the worst case overshoot. Further, the voltage must not fall below the VCC minimum operating voltage of 7 V during heavy loading, transients, or line disturbances. A series resistance calculated example of operation at 310 kHz is shown in Equation 2. In this case, a 1.96 kΩ resistor can be used to make the VCC node more robust.

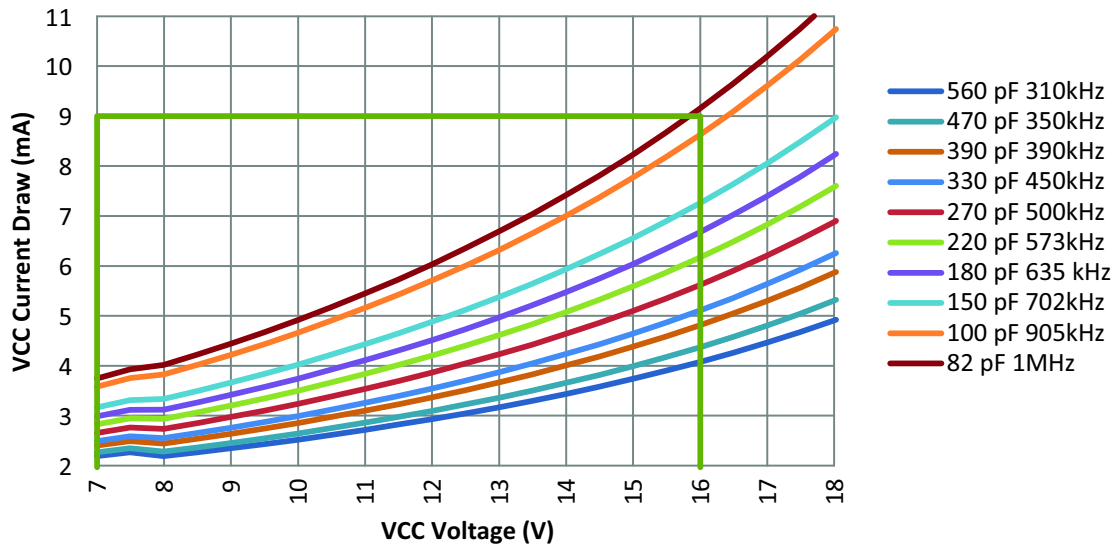
### Calculation of RC

$$16 \text{ V} \geq V_{\text{OUTaux}} - I_{\text{C\_current}} \cdot RC \geq 7.0 \text{ V} \quad (\text{eq. 2})$$

$$\frac{V_{\text{OUTaux}} - 16 \text{ V}}{I_{\text{C\_current}}} = RC$$

$$\frac{24 \text{ V} - 16 \text{ V}}{4.075 \text{ mA}} = 1.96 \text{ k}\Omega$$

$$\frac{12.5 \text{ V} - 7.0 \text{ V}}{2.65 \text{ mA}} = 2.07 \text{ k}\Omega$$



**Figure 40. NCP1031 Current Draw vs. Frequency and VCC Voltage**

The series resistor needs to be coupled with proper sizing of the auxiliary winding and VCC capacitance. The CAUX1 and CAUX2 should be approximately the same size where the CVCC should be between 1/10 to 1/100 the value of CAUX2. The smaller size of CVCC serves to reduce the amount of energy available to the internal clamping structures in the event of a large unforeseen over voltage. Proper sizing of capacitance and adding a series resistance can reduce the likelihood of an over voltage on the VCC, but

cannot eliminate the possibility completely. A zener diode can be added along with the series resistance value calculated from Equation 2 which can be split into RC1 and RC2 as shown in Figure 41. If the OV pin is not used, it can be connected to the VCC node to monitor the voltage and suspend switching if the voltage exceeds a predefined level. The addition of the ROV1 and ROV2 will add a current draw from VAUX and will increase the voltage drop across RC.



## NCP1030, NCP1031

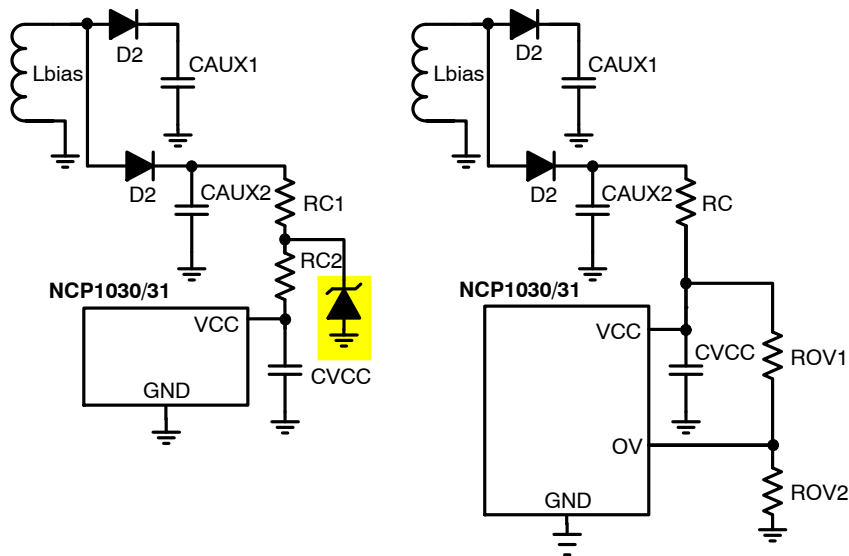


Figure 41. Zener Clamp or OV Protection

The compensation of the NCP1031/30 should be completed with the loop response, the transient response, and the amplifier in mind. The amplifier can source 110  $\mu\text{A}$  and sink 550  $\mu\text{A}$  typical. Internally the current sink that pulls down the amplifier has an on resistance of 2.45  $\text{k}\Omega$  and an

ESD resistance of 1.74  $\text{k}\Omega$  as shown in Figure 42. The two resistances combine to create a maximum pull down current that changes with comp voltage as shown in Figure 43 and Figure 44.

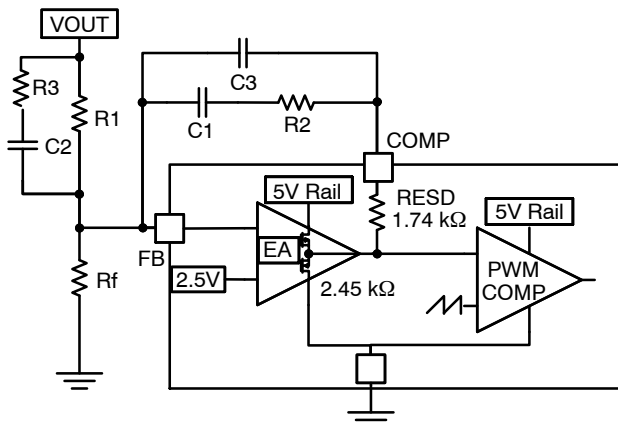


Figure 42. Internal Error Amplifier Structure

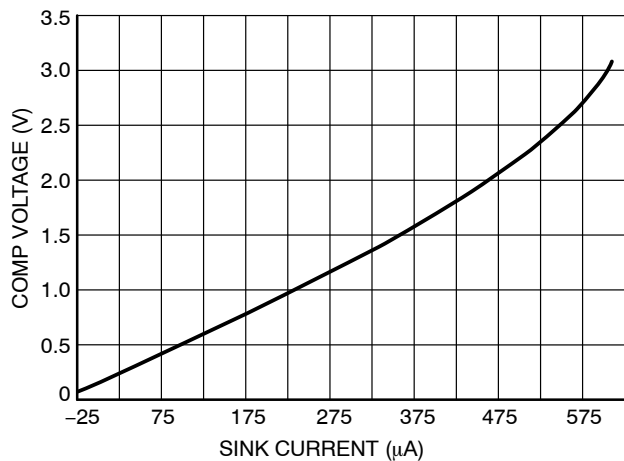


Figure 43. Sink Current vs. Comp Voltage

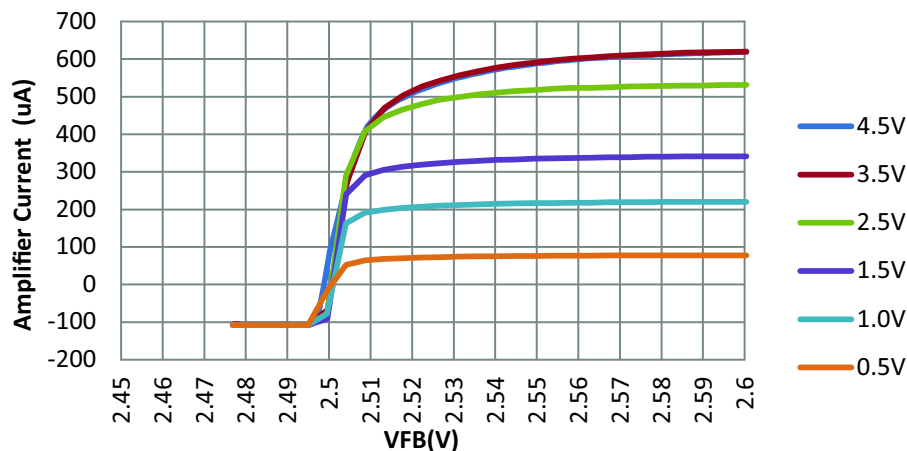


Figure 44. Amplifier Sink Current with Comp at Steady Voltage vs Feedback Voltage

## NCP1030, NCP1031

One source of overshoot in the system can occur during startup where the reference voltage starts at 2.5 V and the system PWM regulates to the desired output voltage. The power is limited to the system by the internally set current limit. Since the voltage feedback loop sees the output voltage is lower than it should be, the COMP voltage slews up to increase the duty cycle, but the duty cycle is controlled by the pulse by pulse current limit. Once regulated output voltage is reached, the current loop will maintain control for the time it takes the COMP pin to slew from 5 V to 3.25 V where the voltage loop takes control and the pulse by pulse current limit is no longer limiting the system. The same is true for an overload or current limit. If the COMP voltage has reached a steady state value of 5 V, the required compensation value needed to slew from 5 V to 3.25 V is

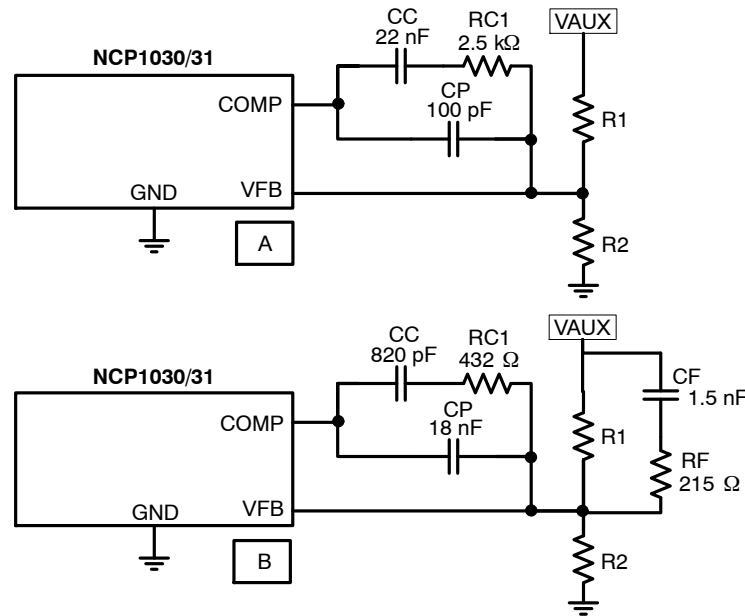
shown in Equation 3. Equation 3 is true if the feedback node has very low impedance at 2.5 V. For comparison, the decay from 5 V to 3.25 V in network A occurs in 259 ns and network B occurs in 12.2  $\mu$ s although they have a very similar frequency response.

$$RC1 = \frac{V_{COMP\_INIT} - V_{COMP\_FINAL}}{I_{PULL\_DOWN}} \quad (\text{eq. 3})$$

$$3.5 \text{ k}\Omega = \frac{5 \text{ V} - 3.25 \text{ V}}{500 \mu\text{A}}$$

$$\text{Time} = CP \cdot \frac{V_{COMP\_INIT} - V_{COMP\_FINAL}}{I_{PULL\_DOWN}}$$

$$300 \text{ ns} = 100 \text{ pF} \cdot \frac{5 \text{ V} - 3.25 \text{ V}}{500 \mu\text{A}}$$



**Figure 45. Compensation for Good Transient Response**

When considering compensation and overshoot, the designer should follow a few rules for a better result.

1. If the current flowing through R1 and R2 is 10X larger than 620  $\mu$ A then the RF and CF contribution to the large signal is small.
  - a.) If RF is small (1  $\Omega$  -100  $\Omega$ ) there is only a small DC shift from RC1.
  - b.) To create a large DC shift down, increase RF (1 k $\Omega$  -10 k $\Omega$ ).

2. Keep CP small (CP < 1 nF) or it will slow the large signal response of the converter.
3. CF should be less than 22 nF.
4. RC1 should be 2.7 k < RC1 < 100 k.

## NCP1030, NCP1031

### ORDERING INFORMATION

Device	Package	Shipping†
NCP1030DMR2	Micro8	4000 / Tape & Reel
NCP1030DMR2G	Micro8 (Pb-Free)	4000 / Tape & Reel
NCP1031DR2	SOIC-8	2500 / Tape & Reel
NCP1031DR2G	SOIC-8 (Pb-Free)	2500 / Tape & Reel
NCP1031MNTXG	DFN8 (Pb-Free)	4000 / Tape & Reel

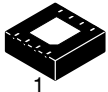
†For information on tape and reel specifications, including part orientation and tape sizes, please refer to our Tape and Reel Packaging Specifications Brochure, BRD8011/D.

SENSEFET is a registered trademark of Semiconductor Components Industries, LLC dba "onsemi" or its affiliates and/or subsidiaries in the United States and/or other countries.

# MECHANICAL CASE OUTLINE

## PACKAGE DIMENSIONS

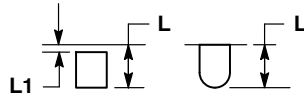
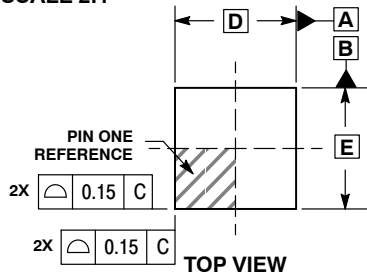
ON Semiconductor®



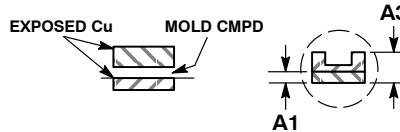
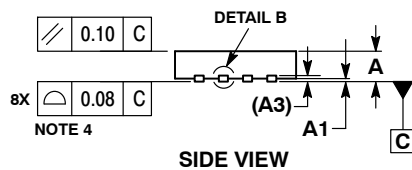
SCALE 2:1

### DFN8, 4x4 CASE 488AF-01 ISSUE C

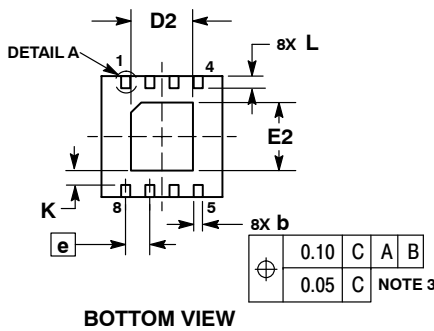
DATE 15 JAN 2009



DETAIL A  
OPTIONAL  
CONSTRUCTIONS

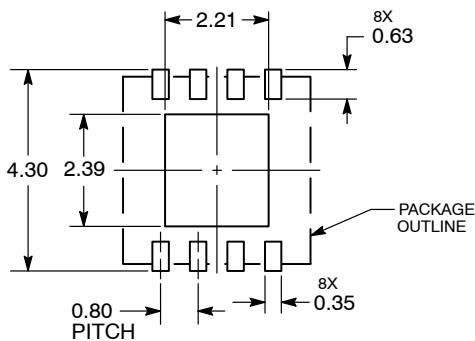


DETAIL B  
ALTERNATE  
CONSTRUCTIONS



BOTTOM VIEW

#### SOLDERING FOOTPRINT\*



DIMENSIONS: MILLIMETERS

NOTES:

1. DIMENSIONS AND TOLERANCING PER ASME Y14.5M, 1994.
2. CONTROLLING DIMENSION: MILLIMETERS.
3. DIMENSION b APPLIES TO PLATED TERMINAL AND IS MEASURED BETWEEN 0.15 AND 0.30MM FROM TERMINAL TIP.
4. COPLANARITY APPLIES TO THE EXPOSED PAD AS WELL AS THE TERMINALS.
5. DETAILS A AND B SHOW OPTIONAL CONSTRUCTIONS FOR TERMINALS.

MILLIMETERS		
DIM	MIN	MAX
A	0.80	1.00
A1	0.00	0.05
A3	0.20	REF
b	0.25	0.35
D	4.00	BSC
D2	1.91	2.21
E	4.00	BSC
E2	2.09	2.39
e	0.80	BSC
K	0.20	---
L	0.30	0.50
L1	---	0.15

#### GENERIC MARKING DIAGRAM\*



- XXXX = Specific Device Code
- A = Assembly Location
- L = Wafer Lot
- Y = Year
- W = Work Week
- = Pb-Free Package

(Note: Microdot may be in either location)

\*This information is generic. Please refer to device data sheet for actual part marking. Pb-Free indicator, "G" or microdot "▪", may or may not be present.

\*For additional information on our Pb-Free strategy and soldering details, please download the ON Semiconductor Soldering and Mounting Techniques Reference Manual, SOLDERRM/D.

DOCUMENT NUMBER:	98AON15232D	Electronic versions are uncontrolled except when accessed directly from the Document Repository. Printed versions are uncontrolled except when stamped "CONTROLLED COPY" in red.
DESCRIPTION:	DFN8, 4X4, 0.8P	PAGE 1 OF 1

ON Semiconductor and ON are trademarks of Semiconductor Components Industries, LLC dba ON Semiconductor or its subsidiaries in the United States and/or other countries. ON Semiconductor reserves the right to make changes without further notice to any products herein. ON Semiconductor makes no warranty, representation or guarantee regarding the suitability of its products for any particular purpose, nor does ON Semiconductor assume any liability arising out of the application or use of any product or circuit, and specifically disclaims any and all liability, including without limitation special, consequential or incidental damages. ON Semiconductor does not convey any license under its patent rights nor the rights of others.

# MECHANICAL CASE OUTLINE PACKAGE DIMENSIONS

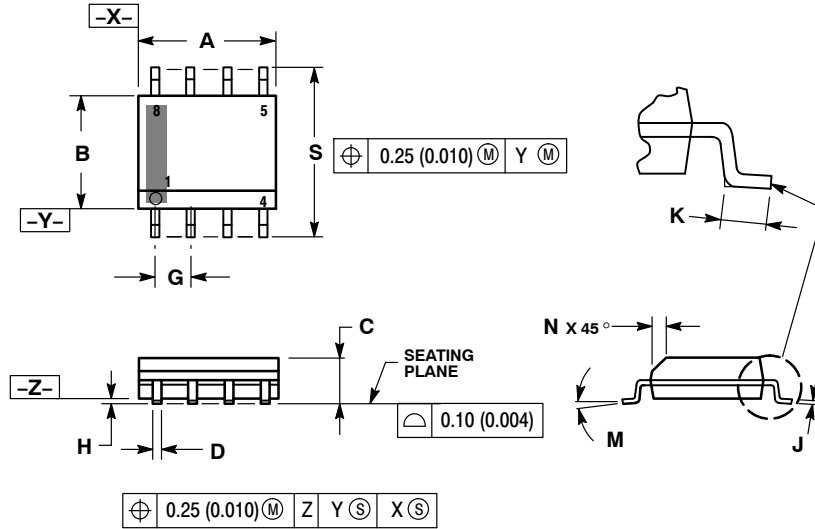
ON Semiconductor®



SCALE 1:1

SOIC-8 NB  
CASE 751-07  
ISSUE AK

DATE 16 FEB 2011

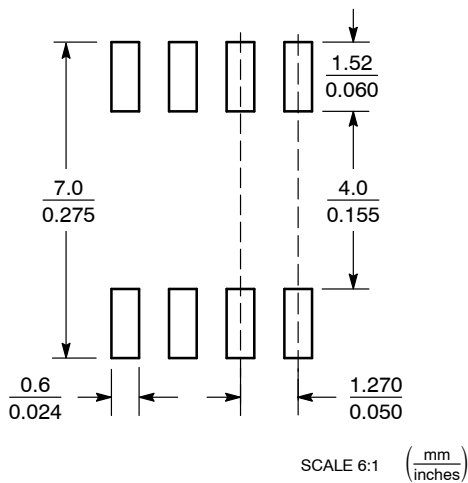


- NOTES:
1. DIMENSIONING AND TOLERANCING PER ANSI Y14.5M, 1982.
  2. CONTROLLING DIMENSION: MILLIMETER.
  3. DIMENSION A AND B DO NOT INCLUDE MOLD PROTRUSION.
  4. MAXIMUM MOLD PROTRUSION 0.15 (0.006) PER SIDE.
  5. DIMENSION D DOES NOT INCLUDE DAMBAR PROTRUSION. ALLOWABLE DAMBAR PROTRUSION SHALL BE 0.127 (0.005) TOTAL IN EXCESS OF THE D DIMENSION AT MAXIMUM MATERIAL CONDITION.
  6. 751-01 THRU 751-06 ARE OBSOLETE. NEW STANDARD IS 751-07.

DIM	MILLIMETERS		INCHES	
	MIN	MAX	MIN	MAX
A	4.80	5.00	0.189	0.197
B	3.80	4.00	0.150	0.157
C	1.35	1.75	0.053	0.069
D	0.33	0.51	0.013	0.020
G	1.27 BSC		0.050 BSC	
H	0.10	0.25	0.004	0.010
J	0.19	0.25	0.007	0.010
K	0.40	1.27	0.016	0.050
M	0°	8°	0°	8°
N	0.25	0.50	0.010	0.020
S	5.80	6.20	0.228	0.244

## GENERIC MARKING DIAGRAM\*

### SOLDERING FOOTPRINT\*



XXXXXX = Specific Device Code  
 A = Assembly Location  
 L = Wafer Lot  
 Y = Year  
 W = Work Week  
 ■ = Pb-Free Package

XXXXXX = Specific Device Code  
 A = Assembly Location  
 Y = Year  
 WW = Work Week  
 ■ = Pb-Free Package

\*This information is generic. Please refer to device data sheet for actual part marking. Pb-Free indicator, "G" or microdot "•", may or may not be present. Some products may not follow the Generic Marking.

\*For additional information on our Pb-Free strategy and soldering details, please download the ON Semiconductor Soldering and Mounting Techniques Reference Manual, SOLDERRM/D.

STYLES ON PAGE 2

DOCUMENT NUMBER:	98ASB42564B	Electronic versions are uncontrolled except when accessed directly from the Document Repository. Printed versions are uncontrolled except when stamped "CONTROLLED COPY" in red.
DESCRIPTION:	SOIC-8 NB	PAGE 1 OF 2

ON Semiconductor and ON are trademarks of Semiconductor Components Industries, LLC dba ON Semiconductor or its subsidiaries in the United States and/or other countries. ON Semiconductor reserves the right to make changes without further notice to any products herein. ON Semiconductor makes no warranty, representation or guarantee regarding the suitability of its products for any particular purpose, nor does ON Semiconductor assume any liability arising out of the application or use of any product or circuit, and specifically disclaims any and all liability, including without limitation special, consequential or incidental damages. ON Semiconductor does not convey any license under its patent rights nor the rights of others.

**SOIC-8 NB**  
**CASE 751-07**  
**ISSUE AK**

DATE 16 FEB 2011

- |  |   |   |   |
|--|---|---|---|
| <p><b>STYLE 1:</b><br/> PIN 1. EMITTER<br/> 2. COLLECTOR<br/> 3. COLLECTOR<br/> 4. EMITTER<br/> 5. EMITTER<br/> 6. BASE<br/> 7. BASE<br/> 8. EMITTER</p>   | <p><b>STYLE 2:</b><br/> PIN 1. COLLECTOR, DIE, #1<br/> 2. COLLECTOR, #1<br/> 3. COLLECTOR, #2<br/> 4. COLLECTOR, #2<br/> 5. BASE, #2<br/> 6. EMITTER, #2<br/> 7. BASE, #1<br/> 8. EMITTER, #1</p>               | <p><b>STYLE 3:</b><br/> PIN 1. DRAIN, DIE #1<br/> 2. DRAIN, #1<br/> 3. DRAIN, #2<br/> 4. DRAIN, #2<br/> 5. GATE, #2<br/> 6. SOURCE, #2<br/> 7. GATE, #1<br/> 8. SOURCE, #1</p>                            | <p><b>STYLE 4:</b><br/> PIN 1. ANODE<br/> 2. ANODE<br/> 3. ANODE<br/> 4. ANODE<br/> 5. ANODE<br/> 6. ANODE<br/> 7. ANODE<br/> 8. COMMON CATHODE</p>   |
| <p><b>STYLE 5:</b><br/> PIN 1. DRAIN<br/> 2. DRAIN<br/> 3. DRAIN<br/> 4. DRAIN<br/> 5. GATE<br/> 6. GATE<br/> 7. SOURCE<br/> 8. SOURCE</p>   | <p><b>STYLE 6:</b><br/> PIN 1. SOURCE<br/> 2. DRAIN<br/> 3. DRAIN<br/> 4. SOURCE<br/> 5. SOURCE<br/> 6. GATE<br/> 7. GATE<br/> 8. SOURCE</p>  | <p><b>STYLE 7:</b><br/> PIN 1. INPUT<br/> 2. EXTERNAL BYPASS<br/> 3. THIRD STAGE SOURCE<br/> 4. GROUND<br/> 5. DRAIN<br/> 6. GATE 3<br/> 7. SECOND STAGE Vd<br/> 8. FIRST STAGE Vd</p>                    | <p><b>STYLE 8:</b><br/> PIN 1. COLLECTOR, DIE #1<br/> 2. BASE, #1<br/> 3. BASE, #2<br/> 4. COLLECTOR, #2<br/> 5. COLLECTOR, #2<br/> 6. EMITTER, #2<br/> 7. EMITTER, #1<br/> 8. COLLECTOR, #1</p>                              |
| <p><b>STYLE 9:</b><br/> PIN 1. EMITTER, COMMON<br/> 2. COLLECTOR, DIE #1<br/> 3. COLLECTOR, DIE #2<br/> 4. EMITTER, COMMON<br/> 5. EMITTER, COMMON<br/> 6. BASE, DIE #2<br/> 7. BASE, DIE #1<br/> 8. EMITTER, COMMON</p> | <p><b>STYLE 10:</b><br/> PIN 1. GROUND<br/> 2. BIAS 1<br/> 3. OUTPUT<br/> 4. GROUND<br/> 5. GROUND<br/> 6. BIAS 2<br/> 7. INPUT<br/> 8. GROUND</p>  | <p><b>STYLE 11:</b><br/> PIN 1. SOURCE 1<br/> 2. GATE 1<br/> 3. SOURCE 2<br/> 4. GATE 2<br/> 5. DRAIN 2<br/> 6. DRAIN 2<br/> 7. DRAIN 1<br/> 8. DRAIN 1</p>   | <p><b>STYLE 12:</b><br/> PIN 1. SOURCE<br/> 2. SOURCE<br/> 3. SOURCE<br/> 4. GATE<br/> 5. DRAIN<br/> 6. DRAIN<br/> 7. DRAIN<br/> 8. DRAIN</p>   |
| <p><b>STYLE 13:</b><br/> PIN 1. N.C.<br/> 2. SOURCE<br/> 3. SOURCE<br/> 4. GATE<br/> 5. DRAIN<br/> 6. DRAIN<br/> 7. DRAIN<br/> 8. DRAIN</p>  | <p><b>STYLE 14:</b><br/> PIN 1. N-SOURCE<br/> 2. N-GATE<br/> 3. P-SOURCE<br/> 4. P-GATE<br/> 5. P-DRAIN<br/> 6. P-DRAIN<br/> 7. N-DRAIN<br/> 8. N-DRAIN</p>   | <p><b>STYLE 15:</b><br/> PIN 1. ANODE 1<br/> 2. ANODE 1<br/> 3. ANODE 1<br/> 4. ANODE 1<br/> 5. CATHODE, COMMON<br/> 6. CATHODE, COMMON<br/> 7. CATHODE, COMMON<br/> 8. CATHODE, COMMON</p>               | <p><b>STYLE 16:</b><br/> PIN 1. EMITTER, DIE #1<br/> 2. BASE, DIE #1<br/> 3. EMITTER, DIE #2<br/> 4. BASE, DIE #2<br/> 5. COLLECTOR, DIE #2<br/> 6. COLLECTOR, DIE #2<br/> 7. COLLECTOR, DIE #1<br/> 8. COLLECTOR, DIE #1</p> |
| <p><b>STYLE 17:</b><br/> PIN 1. VCC<br/> 2. V2OUT<br/> 3. V1OUT<br/> 4. TXE<br/> 5. RXE<br/> 6. VEE<br/> 7. GND<br/> 8. ACC</p>  | <p><b>STYLE 18:</b><br/> PIN 1. ANODE<br/> 2. ANODE<br/> 3. SOURCE<br/> 4. GATE<br/> 5. DRAIN<br/> 6. DRAIN<br/> 7. CATHODE<br/> 8. CATHODE</p>   | <p><b>STYLE 19:</b><br/> PIN 1. SOURCE 1<br/> 2. GATE 1<br/> 3. SOURCE 2<br/> 4. GATE 2<br/> 5. DRAIN 2<br/> 6. MIRROR 2<br/> 7. DRAIN 1<br/> 8. MIRROR 1</p>   | <p><b>STYLE 20:</b><br/> PIN 1. SOURCE (N)<br/> 2. GATE (N)<br/> 3. SOURCE (P)<br/> 4. GATE (P)<br/> 5. DRAIN<br/> 6. DRAIN<br/> 7. DRAIN<br/> 8. DRAIN</p>   |
| <p><b>STYLE 21:</b><br/> PIN 1. CATHODE 1<br/> 2. CATHODE 2<br/> 3. CATHODE 3<br/> 4. CATHODE 4<br/> 5. CATHODE 5<br/> 6. COMMON ANODE<br/> 7. COMMON ANODE<br/> 8. CATHODE 6</p>  | <p><b>STYLE 22:</b><br/> PIN 1. I/O LINE 1<br/> 2. COMMON CATHODE/VCC<br/> 3. COMMON CATHODE/VCC<br/> 4. I/O LINE 3<br/> 5. COMMON ANODE/GND<br/> 6. I/O LINE 4<br/> 7. I/O LINE 5<br/> 8. COMMON ANODE/GND</p> | <p><b>STYLE 23:</b><br/> PIN 1. LINE 1 IN<br/> 2. COMMON ANODE/GND<br/> 3. COMMON ANODE/GND<br/> 4. LINE 2 IN<br/> 5. LINE 2 OUT<br/> 6. COMMON ANODE/GND<br/> 7. COMMON ANODE/GND<br/> 8. LINE 1 OUT</p> | <p><b>STYLE 24:</b><br/> PIN 1. BASE<br/> 2. EMITTER<br/> 3. COLLECTOR/ANODE<br/> 4. COLLECTOR/ANODE<br/> 5. CATHODE<br/> 6. CATHODE<br/> 7. COLLECTOR/ANODE<br/> 8. COLLECTOR/ANODE</p>                                      |
| <p><b>STYLE 25:</b><br/> PIN 1. VIN<br/> 2. N/C<br/> 3. REXT<br/> 4. GND<br/> 5. IOUT<br/> 6. IOUT<br/> 7. IOUT<br/> 8. IOUT</p>   | <p><b>STYLE 26:</b><br/> PIN 1. GND<br/> 2. dv/dt<br/> 3. ENABLE<br/> 4. ILIMIT<br/> 5. SOURCE<br/> 6. SOURCE<br/> 7. SOURCE<br/> 8. VCC</p>  | <p><b>STYLE 27:</b><br/> PIN 1. ILIMIT<br/> 2. OVLO<br/> 3. UVLO<br/> 4. INPUT+<br/> 5. SOURCE<br/> 6. SOURCE<br/> 7. SOURCE<br/> 8. DRAIN</p>  | <p><b>STYLE 28:</b><br/> PIN 1. SW_TO_GND<br/> 2. DASIC OFF<br/> 3. DASIC_SW_DET<br/> 4. GND<br/> 5. V_MON<br/> 6. VBULK<br/> 7. VBULK<br/> 8. VIN</p>  |
| <p><b>STYLE 29:</b><br/> PIN 1. BASE, DIE #1<br/> 2. EMITTER, #1<br/> 3. BASE, #2<br/> 4. EMITTER, #2<br/> 5. COLLECTOR, #2<br/> 6. COLLECTOR, #2<br/> 7. COLLECTOR, #1<br/> 8. COLLECTOR, #1</p>                        | <p><b>STYLE 30:</b><br/> PIN 1. DRAIN 1<br/> 2. DRAIN 1<br/> 3. GATE 2<br/> 4. SOURCE 2<br/> 5. SOURCE 1/DRAIN 2<br/> 6. SOURCE 1/DRAIN 2<br/> 7. SOURCE 1/DRAIN 2<br/> 8. GATE 1</p>                           |   |   |

<b>DOCUMENT NUMBER:</b>	<b>98ASB42564B</b>	Electronic versions are uncontrolled except when accessed directly from the Document Repository. Printed versions are uncontrolled except when stamped "CONTROLLED COPY" in red.
<b>DESCRIPTION:</b>	<b>SOIC-8 NB</b>	<b>PAGE 2 OF 2</b>

ON Semiconductor and  are trademarks of Semiconductor Components Industries, LLC dba ON Semiconductor or its subsidiaries in the United States and/or other countries. ON Semiconductor reserves the right to make changes without further notice to any products herein. ON Semiconductor makes no warranty, representation or guarantee regarding the suitability of its products for any particular purpose, nor does ON Semiconductor assume any liability arising out of the application or use of any product or circuit, and specifically disclaims any and all liability, including without limitation special, consequential or incidental damages. ON Semiconductor does not convey any license under its patent rights nor the rights of others.

# MECHANICAL CASE OUTLINE

## PACKAGE DIMENSIONS

ON Semiconductor®



SCALE 2:1

### Micro8 CASE 846A-02 ISSUE K

DATE 16 JUL 2020



TOP VIEW

NOTE 3



SIDE VIEW



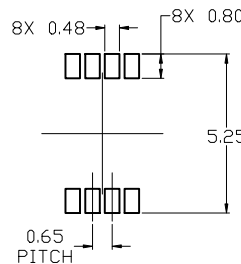
END VIEW

**NOTES:**

1. DIMENSIONING AND TOLERANCING PER ASME Y14.5M, 2009.
2. CONTROLLING DIMENSION: MILLIMETERS
3. DIMENSION *b* DOES NOT INCLUDE DAMBAR PROTRUSION. ALLOWABLE PROTRUSION SHALL BE 0.10 mm IN EXCESS OF MAXIMUM MATERIAL CONDITION.
4. DIMENSIONS *D* AND *E* DO NOT INCLUDE MOLD FLASH, PROTRUSION OR GATE BURRS. MOLD FLASH, PROTRUSIONS, OR GATE BURRS SHALL NOT EXCEED 0.15 mm PER SIDE. DIMENSION *E* DOES NOT INCLUDE INTERLEAD FLASH OR PROTRUSION. INTERLEAD FLASH OR PROTRUSION SHALL NOT EXCEED 0.25 mm PER SIDE. DIMENSIONS *D* AND *E* ARE DETERMINED AT DATUM *F*.
5. DATUMS *A* AND *B* ARE TO BE DETERMINED AT DATUM *F*.
6. *A1* IS DEFINED AS THE VERTICAL DISTANCE FROM THE SEATING PLANE TO THE LOWEST POINT ON THE PACKAGE BODY.

$\phi 0.08$  (0.003) M C B S A S

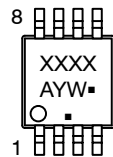
DIM	MILLIMETERS		
	MIN.	NOM.	MAX.
A	---	---	1.10
A1	0.05	0.08	0.15
<i>b</i>	0.25	0.33	0.40
<i>c</i>	0.13	0.18	0.23
<i>D</i>	2.90	3.00	3.10
<i>E</i>	2.90	3.00	3.10
<i>e</i>	0.65 BSC		
<i>H<sub>E</sub></i>	4.75	4.90	5.05
<i>L</i>	0.40	0.55	0.70



RECOMMENDED MOUNTING FOOTPRINT

For additional information on our Pb-Free strategy and soldering details, please download the ON Semiconductor Soldering and Mounting Techniques Reference Manual, SOLDERM/D.

### GENERIC MARKING DIAGRAM\*



- XXXX = Specific Device Code
- A = Assembly Location
- Y = Year
- W = Work Week
- = Pb-Free Package

(Note: Microdot may be in either location)

\*This information is generic. Please refer to device data sheet for actual part marking. Pb-Free indicator, "G" or microdot "▪", may or may not be present. Some products may not follow the Generic Marking.

**STYLE 1:**

1. SOURCE
2. SOURCE
3. SOURCE
4. GATE
5. DRAIN
6. DRAIN
7. DRAIN
8. DRAIN

**STYLE 2:**

1. SOURCE 1
2. GATE 1
3. SOURCE 2
4. GATE 2
5. DRAIN 2
6. DRAIN 2
7. DRAIN 1
8. DRAIN 1

**STYLE 3:**

1. N-SOURCE
2. N-GATE
3. P-SOURCE
4. P-GATE
5. P-DRAIN
6. P-DRAIN
7. N-DRAIN
8. N-DRAIN

<b>DOCUMENT NUMBER:</b>	<b>98ASB14087C</b>	Electronic versions are uncontrolled except when accessed directly from the Document Repository. Printed versions are uncontrolled except when stamped "CONTROLLED COPY" in red.
<b>DESCRIPTION:</b>	<b>MICRO8</b>	<b>PAGE 1 OF 1</b>

ON Semiconductor and ON are trademarks of Semiconductor Components Industries, LLC dba ON Semiconductor or its subsidiaries in the United States and/or other countries. ON Semiconductor reserves the right to make changes without further notice to any products herein. ON Semiconductor makes no warranty, representation or guarantee regarding the suitability of its products for any particular purpose, nor does ON Semiconductor assume any liability arising out of the application or use of any product or circuit, and specifically disclaims any and all liability, including without limitation special, consequential or incidental damages. ON Semiconductor does not convey any license under its patent rights nor the rights of others.

**onsemi**, **Onsemi**, and other names, marks, and brands are registered and/or common law trademarks of Semiconductor Components Industries, LLC dba "**onsemi**" or its affiliates and/or subsidiaries in the United States and/or other countries. **onsemi** owns the rights to a number of patents, trademarks, copyrights, trade secrets, and other intellectual property. A listing of **onsemi**'s product/patent coverage may be accessed at [www.onsemi.com/site/pdf/Patent-Marking.pdf](http://www.onsemi.com/site/pdf/Patent-Marking.pdf). **onsemi** reserves the right to make changes at any time to any products or information herein, without notice. The information herein is provided "as-is" and **onsemi** makes no warranty, representation or guarantee regarding the accuracy of the information, product features, availability, functionality, or suitability of its products for any particular purpose, nor does **onsemi** assume any liability arising out of the application or use of any product or circuit, and specifically disclaims any and all liability, including without limitation special, consequential or incidental damages. Buyer is responsible for its products and applications using **onsemi** products, including compliance with all laws, regulations and safety requirements or standards, regardless of any support or applications information provided by **onsemi**. "Typical" parameters which may be provided in **onsemi** data sheets and/or specifications can and do vary in different applications and actual performance may vary over time. All operating parameters, including "Typicals" must be validated for each customer application by customer's technical experts. **onsemi** does not convey any license under any of its intellectual property rights nor the rights of others. **onsemi** products are not designed, intended, or authorized for use as a critical component in life support systems or any FDA Class 3 medical devices or medical devices with a same or similar classification in a foreign jurisdiction or any devices intended for implantation in the human body. Should Buyer purchase or use **onsemi** products for any such unintended or unauthorized application, Buyer shall indemnify and hold **onsemi** and its officers, employees, subsidiaries, affiliates, and distributors harmless against all claims, costs, damages, and expenses, and reasonable attorney fees arising out of, directly or indirectly, any claim of personal injury or death associated with such unintended or unauthorized use, even if such claim alleges that **onsemi** was negligent regarding the design or manufacture of the part. **onsemi** is an Equal Opportunity/Affirmative Action Employer. This literature is subject to all applicable copyright laws and is not for resale in any manner.

## PUBLICATION ORDERING INFORMATION

### LITERATURE FULFILLMENT:

Email Requests to: [orderlit@onsemi.com](mailto:orderlit@onsemi.com)

**onsemi Website:** [www.onsemi.com](http://www.onsemi.com)

### TECHNICAL SUPPORT

**North American Technical Support:**

Voice Mail: 1 800-282-9855 Toll Free USA/Canada

Phone: 011 421 33 790 2910

**Europe, Middle East and Africa Technical Support:**

Phone: 00421 33 790 2910

For additional information, please contact your local Sales Representative



## X-ON Electronics

Largest Supplier of Electrical and Electronic Components

*Click to view similar products for [Switching Controllers](#) category:*

*Click to view products by [ON Semiconductor](#) manufacturer:*

Other Similar products are found below :

[AZ7500EP-E1](#) [NCP1218AD65R2G](#) [NCP1234AD100R2G](#) [NCP1244BD065R2G](#) [NCP1336ADR2G](#) [NCP6153MNTWG](#) [NCP81101BMNTXG](#)  
[NCP81205MNTXG](#) [SJE6600](#) [SMBV1061LT1G](#) [SG3845DM](#) [NCP4204MNTXG](#) [NCP6132AMNR2G](#) [NCP81102MNTXG](#)  
[NCP81203MNTXG](#) [NCP81206MNTXG](#) [NX2155HCUPTR](#) [UBA2051C](#) [MAX8778ETJ+](#) [NTBV30N20T4G](#) [NCP1240AD065R2G](#)  
[NCP1240FD065R2G](#) [NCP1361BABAYSNT1G](#) [NTC6600NF](#) [NCP1230P100G](#) [NCP1612BDR2G](#) [NX2124CSTR](#) [SG2845M](#)  
[NCP81101MNTXG](#) [TEA19362T/1J](#) [IFX81481ELV](#) [NCP81174NMNTXG](#) [NCP4308DMTTWG](#) [NCP4308DMNTWG](#) [NCP4308AMTTWG](#)  
[NCP1251FSN65T1G](#) [NCP1246BLD065R2G](#) [NTE7154](#) [NTE7242](#) [LTC7852IUFD-1#PBF](#) [LTC7852EUFD-1#PBF](#) [MB39A136PFT-G-BND-ERE1](#) [NCP1256BSN100T1G](#) [LV5768V-A-TLM-E](#) [NCP1365BABCYDR2G](#) [NCP1365AABCYDR2G](#) [MCP1633T-E/MG](#) [NCV1397ADR2G](#)  
[NCP1246ALD065R2G](#) [AZ494AP-E1](#)