



Test Procedure for the NCP114MXTCEVB Evaluation Board

1. QUIESCENT CURRENT

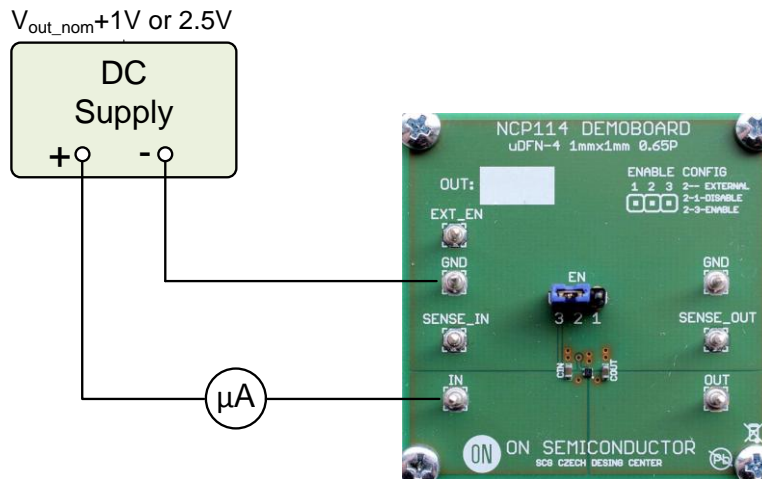

Figure 1: Test configuration for measurement I_Q , Quiescent Current

1. Connect circuit as shown figure on 1
2. Apply voltage at V_{Input} . Default test V_{input} is $V_{out_nom}+1$ V or 2.5 V whichever is greater
3. Value shown μA meter is measured quiescent current.
4. Measurement is finished. Disconnect supply voltage.

**Note – Be carefully if any device is connected on output, because leakage current can affect measurement accuracy.*



2. LOAD REGULATION

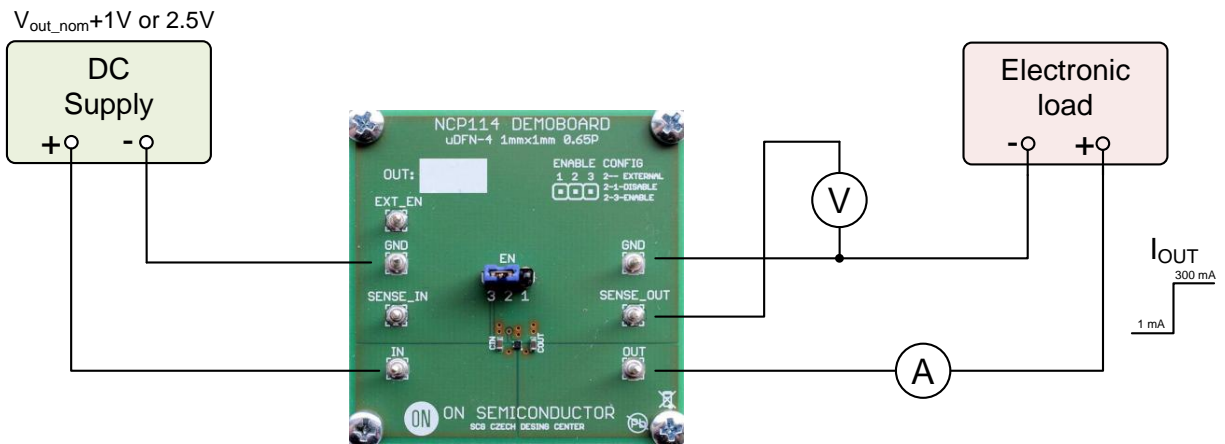

Figure 2: Test configuration for measurement REG_{LOAD} , Load Regulation

1. Connect circuit as shown figure on 2
2. Apply voltage at V_{Input} . Default test V_{input} is $V_{out_nom} + 1$ V or 2.5 V whichever is greater
3. Set minimal required current I_1 , e.g. 1 mA, and switch load ON.
4. Note the value V_1 from voltmeter V_o .
5. Switch load OFF and set maximal required current I_2 , e.g. 300 mA and switch load ON.
6. Note the value V_2 from voltmeter V_o .
7. Load regulation is obtained via following formula: $REG_{LOAD} = (V_1 - V_2)$, [V]
8. Measurement is finished. Disconnect supply voltage.



3. LINE REGULATION

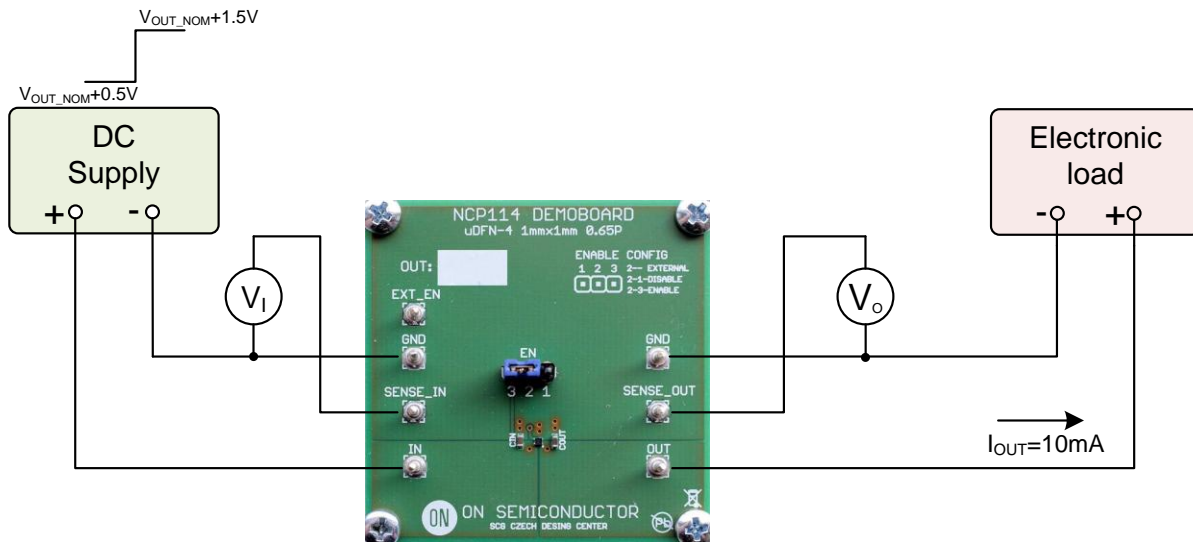

Figure 3: Test configuration for measurement REG_{LINE} , Line Regulation

1. Connect circuit as shown on figure 3
2. Set load to the required current e.g. 10 mA
3. Set minimal input voltage V_{I1} , $V_{OUT_NOM}+1V$ or 2.5V whichever is greater
4. Note the value V_{I1} and V_{O1} .
5. Set maximal input voltage $V_{I2} = 5.5 V$
6. Note the value V_{I2} and V_{O2} .
7. Load regulation is obtained via following formula: $REG_{LINE}=(V_{O1}-V_{O2})/(V_{I1}-V_{I2})$, [V/V]
8. Measurement is finished. Disconnect supply voltage.



4. ENABLE START-UP

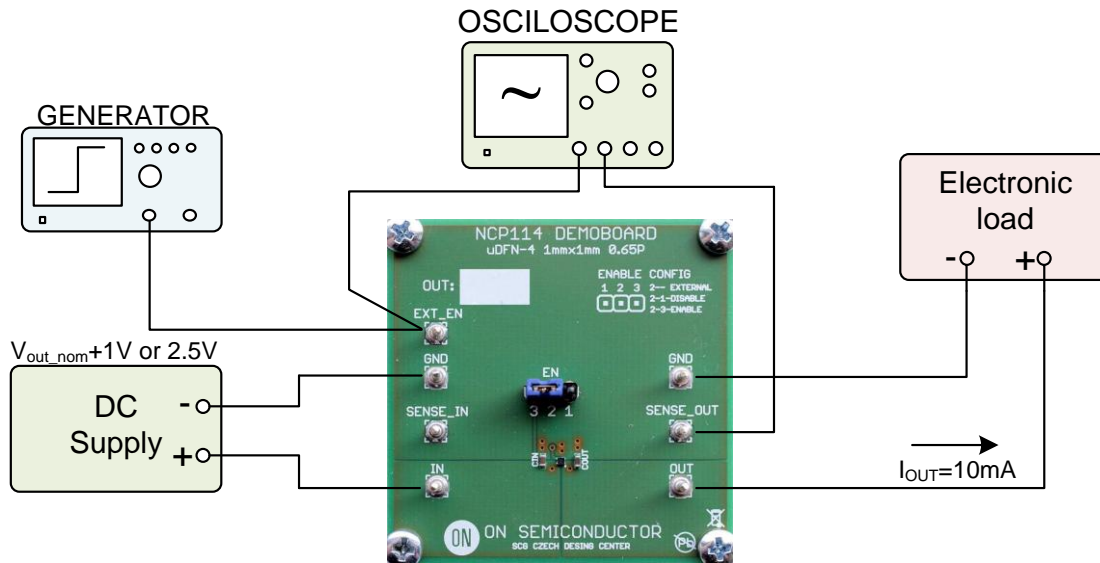

Figure 4: Test configuration for measurement enables response

1. Connect circuit as shown on figure 4
2. Set generator to SQUARE PULSE, $0.9 \leq \text{AMPLITUDE} \leq V_{IN}$, FREQUENCY=10Hz, DUTY=10%
3. Apply voltage at V_{input} . Default test V_{input} is $V_{out_nom}+1$ V or 2.5 V whichever is greater
4. Set required I_{OUT} , e.g. 10 mA
5. Connect oscilloscope to EN signal and V_{OUTPUT} .
6. Watch enable response of the regulator after asserting EN pin.
7. Measurement is finished. Disconnect supply voltage.

X-ON Electronics

Largest Supplier of Electrical and Electronic Components

Click to view similar products for [Power Management IC Development Tools](#) *category:*

Click to view products by [ON Semiconductor](#) *manufacturer:*

Other Similar products are found below :

[EVAL-ADM1168LQEBZ](#) [EVB-EP5348UI](#) [MIC23451-AAAYFL EV](#) [MIC5281YMME EV](#) [DA9063-EVAL](#) [ADP122-3.3-EVALZ](#) [ADP130-0.8-EVALZ](#) [ADP130-1.2-EVALZ](#) [ADP130-1.5-EVALZ](#) [ADP130-1.8-EVALZ](#) [ADP1712-3.3-EVALZ](#) [ADP1714-3.3-EVALZ](#) [ADP1715-3.3-EVALZ](#) [ADP1716-2.5-EVALZ](#) [ADP1740-1.5-EVALZ](#) [ADP1752-1.5-EVALZ](#) [ADP1828LC-EVALZ](#) [ADP1870-0.3-EVALZ](#) [ADP1871-0.6-EVALZ](#) [ADP1873-0.6-EVALZ](#) [ADP1874-0.3-EVALZ](#) [ADP1882-1.0-EVALZ](#) [ADP199CB-EVALZ](#) [ADP2102-1.25-EVALZ](#) [ADP2102-1.875EVALZ](#) [ADP2102-1.8-EVALZ](#) [ADP2102-2-EVALZ](#) [ADP2102-3-EVALZ](#) [ADP2102-4-EVALZ](#) [ADP2106-1.8-EVALZ](#) [ADP2147CB-110EVALZ](#) [AS3606-DB](#) [BQ24010EVM](#) [BQ24075TEVM](#) [BQ24155EVM](#) [BQ24157EVM-697](#) [BQ24160EVM-742](#) [BQ24296MEVM-655](#) [BQ25010EVM](#) [BQ3055EVM](#) [NCV891330PD50GEVB](#) [ISLUSBI2CKIT1Z](#) [LM2744EVAL](#) [LM2854EVAL](#) [LM3658SD-AEV/NOPB](#) [LM3658SDEV/NOPB](#) [LM3691TL-1.8EV/NOPB](#) [LM4510SDEV/NOPB](#) [LM5033SD-EVAL](#) [LP38512TS-1.8EV](#)