

NCP458R, NCP459

4 A Single Load Switch for Low Voltage Rail

The NCP458R and NCP459 are power load switch with very low Ron NMOSFET controlled by external logic pin, allowing optimization of battery life, and portable device autonomy.

Indeed, thanks to a best in class current consumption optimization with NMOS structure, leakage currents are drastically decreased. Offering optimized leakages isolation on the ICs connected on the battery.

Output discharge path is proposed, in the NCP459 version, to eliminate residual voltages on the external components connected on output pin.

Reverse voltage protection, from OUT to IN is offered in the NCP458R version.

Proposed in wide input voltage range from 0.75 V to 5.5 V, and a very small CSP8 1 x 2 mm².

Features

- 0.75 V – 5.5 V Operating Range
- 11 mΩ N-MOSFET
- Vbias Rail Input
- DC Current up to 4 A
- Output Auto-Discharge Option
- Reverse Blocking Option
- Active High EN Pin
- CSP8, 1 x 2 mm², Pitch 0.5 mm

Typical Applications

- Notebooks
- Tablets
- Wireless
- Mobile Phones
- Digital Cameras



ON Semiconductor®

<http://onsemi.com>

MARKING DIAGRAM



WLCSP8
CASE 567HD

XXXX
AYWW▪

- A = Assembly Location
- Y = Year
- WW = Work Week
- = Pb-Free Package

PINOUT

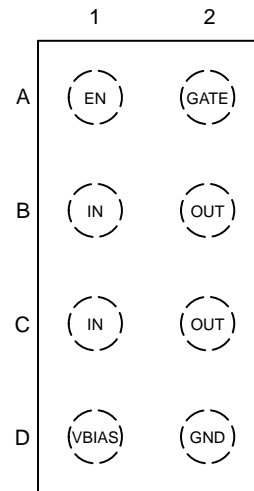

(Top View)

ORDERING INFORMATION

See detailed ordering and shipping information on page 12 of this data sheet.

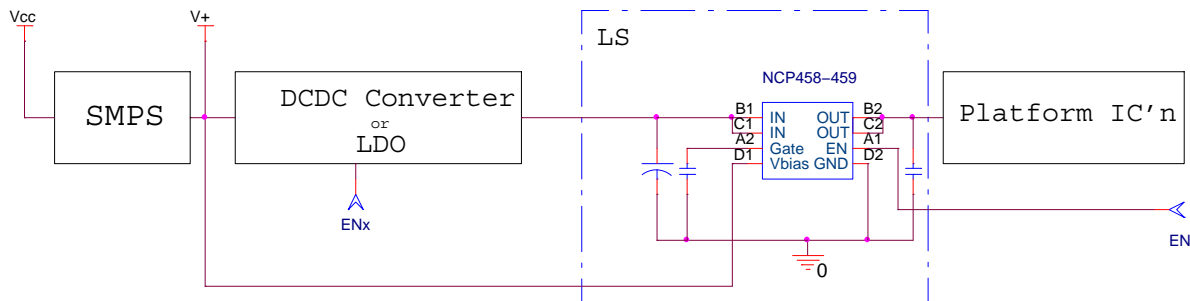

Figure 1. Typical Application Schematic

NCP458R, NCP459

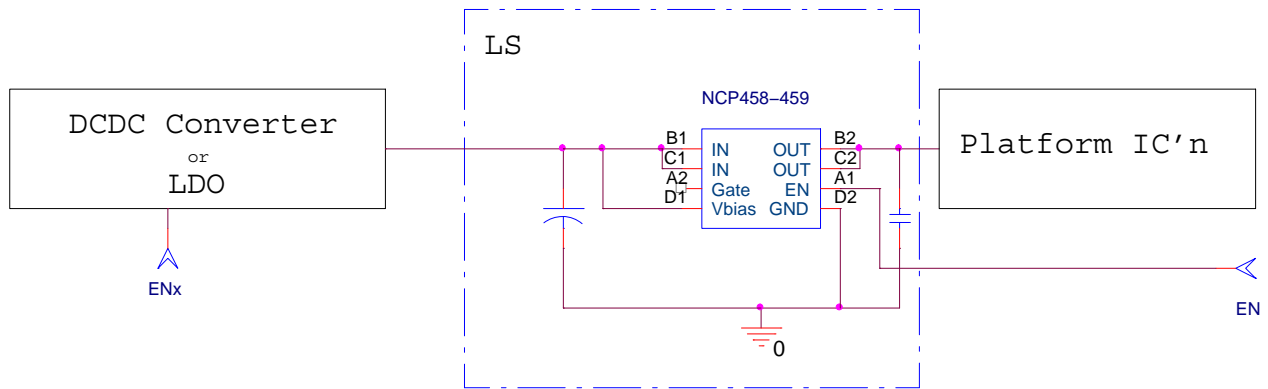

Figure 2. Application Schematic with Vbias Connected to IN and No Gate Delay

PIN FUNCTION DESCRIPTION

Pin Name	Pin Number	Type	Description
EN	A1	INPUT	Enable input, logic high turns on power switch .
IN	B1, C1	POWER	Load-switch input pin.
VBIAS	D1	POWER	External supply voltage input.
GATE	A2	INPUT	OUT pin slew rate control (t_{rise}).
OUT	B2, C2	POWER	Load-switch output pin.
GND	D2	POWER	Ground connection.

NCP458R, NCP459

BLOCK DIAGRAMS

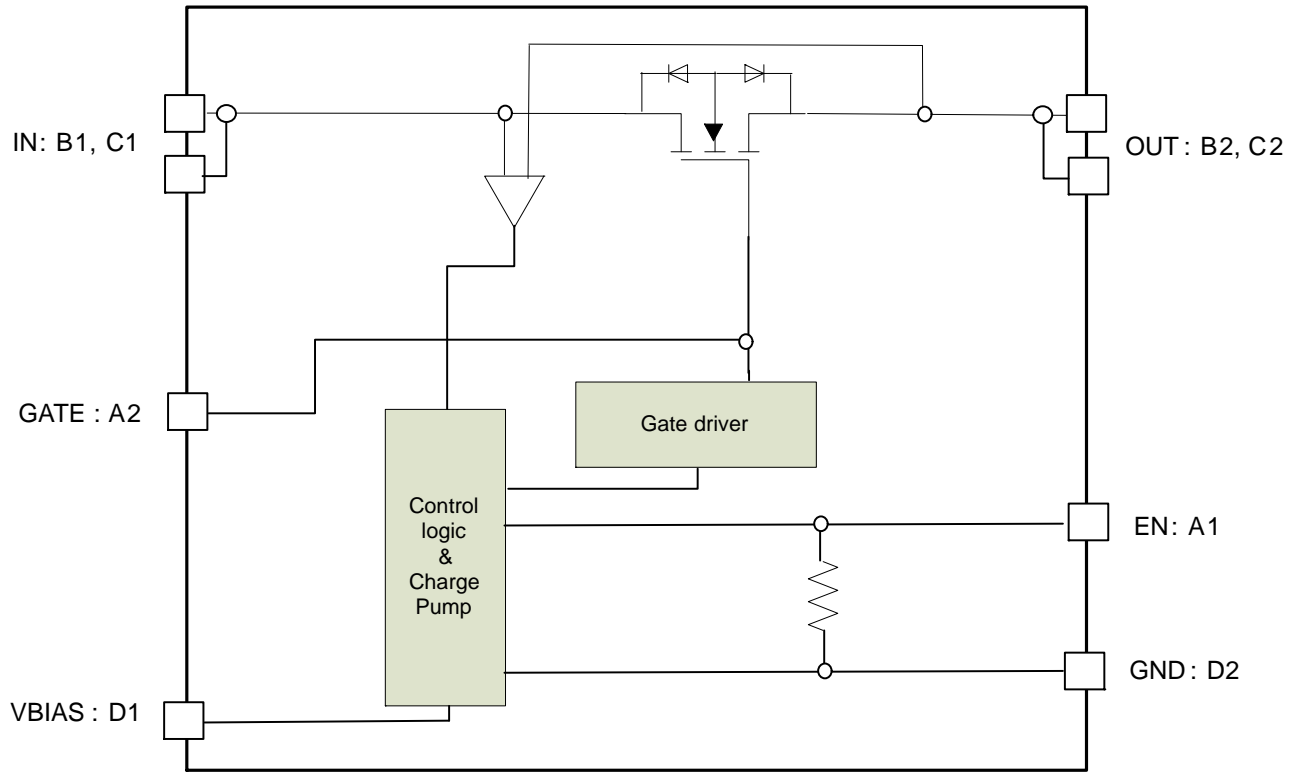

Figure 3. NCP458R Block Diagram

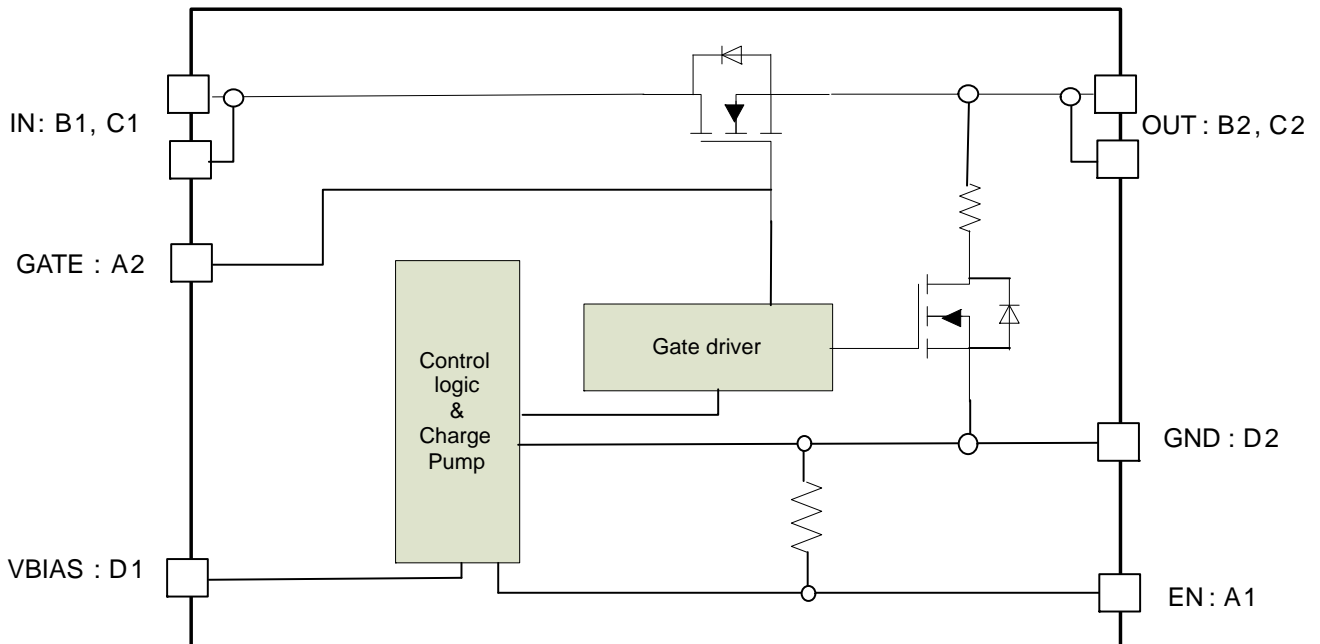

Figure 4. NCP459 Block Diagram

NCP458R, NCP459

MAXIMUM RATINGS

Rating	Symbol	Value	Unit
IN, OUT, EN, VBIAS, GATE Pins: (Note 1)	$V_{EN}, V_{IN}, V_{OUT}, V_{BIAS}, V_{GATE}$	-0.3 to +6.5	V
From IN to OUT Pins: Input/Output (Note 1) NCP459	V_{IN}, V_{OUT}	0 to + 6.5	V
From IN to OUT Pins: Input/Output (Note 1) NCP458R	V_{IN}, V_{OUT}	±6.5	V
Human Body Model (HBM) ESD Rating are (Note 2)	ESD HBM	2000	V
Machine Model (MM) ESD Rating are (Note 2)	ESD MM	200	V
Latch-up protection (Note 3) – Pins IN, OUT, EN, VBIAS and GATE	LU	100	mA
Maximum Junction Temperature	T_J	-40 to + 125	°C
Storage Temperature Range	T_{STG}	-40 to + 150	°C
Moisture Sensitivity (Note 4)	MSL	Level 1	

Stresses exceeding those listed in the Maximum Ratings table may damage the device. If any of these limits are exceeded, device functionality should not be assumed, damage may occur and reliability may be affected.

- According to JEDEC standard JESD22–A108.
- This device series contains ESD protection and passes the following tests:
Human Body Model (HBM) ±2.0 kV per JEDEC standard: JESD22–A114 for all pins.
Machine Model (MM) ±250 V per JEDEC standard: JESD22–A115 for all pins.
- Latch up Current Maximum Rating: ±100 mA per JEDEC standard: JESD78 class II.
- Moisture Sensitivity Level (MSL): 1 per IPC/JEDEC standard: J–STD–020.

OPERATING CONDITIONS

Symbol	Parameter	Conditions	Min	Typ	Max	Unit
V_{IN}	Operational Power Supply		0.75		5.5	V
V_{EN}	Enable Voltage		0		5.5	V
V_{BIAS}	Bias voltage ($V_{BIAS} \geq$ best of V_{IN}, V_{OUT})		1.2		5.5	V
T_A	Ambient Temperature Range		- 40	25	+ 85	°C
C_{IN}	Decoupling input capacitor		100			nF
C_{OUT}	Decoupling output capacitor		100			nF
$R_{\theta JA}$	Thermal Resistance Junction to Air	CSP8 (Note 5)		90		°C/W
I_{OUT}	DC current			4	4.5	A
	AC current 1 ms @ 217 Hz				5	A
	AC current 100 μs spike				15	A
P_D	Power Dissipation Rating (Note 6)			0.315		W

Functional operation above the stresses listed in the Recommended Operating Ranges is not implied. Extended exposure to stresses beyond the Recommended Operating Ranges limits may affect device reliability.

- The $R_{\theta JA}$ is dependent of the PCB heat dissipation and thermal via.
- The maximum power dissipation (P_D) is given by the following formula:

$$P_D = \frac{T_{JMAX} - T_A}{R_{\theta JA}}$$

NCP458R, NCP459

ELECTRICAL CHARACTERISTICS Min & Max Limits apply for T_A between -40°C to $+85^{\circ}\text{C}$ for V_{IN} between 0.75 V and 5.5 V, and V_{BIAS} between 1.2 V and 5.5 V (Unless otherwise noted). Typical values are referenced to $T_A = +25^{\circ}\text{C}$, $V_{IN} = 3.3\text{ V}$ and $V_{BIAS} = 5\text{ V}$ (Unless otherwise noted).

Symbol	Parameter	Conditions	Min	Typ	Max	Unit	
POWER SWITCH							
$R_{DS(on)}$	Static drain-source on-state resistance for each rail	$V_{IN} = V_{BIAS} = 5.5\text{ V}$	$T_A = 25^{\circ}\text{C}$		11	20	m Ω
			$T_J = 125^{\circ}\text{C}$			24	
		$V_{IN} = V_{BIAS} = 3.3\text{ V}$	$T_A = 25^{\circ}\text{C}$		11	20	
			$T_J = 125^{\circ}\text{C}$			24	
		$V_{IN} = V_{BIAS} = 1.8\text{ V}$	$T_A = 25^{\circ}\text{C}$		12	20	
			$T_J = 125^{\circ}\text{C}$			24	
		$V_{IN} = V_{BIAS} = 1.5\text{ V}$	$T_A = 25^{\circ}\text{C}$		13	20	
			$T_J = 125^{\circ}\text{C}$			24	
		$V_{IN} = V_{BIAS} = 1.2\text{ V}$	$T_A = 25^{\circ}\text{C}$		13	20	
			$T_J = 125^{\circ}\text{C}$			24	
$V_{IN} = 1.0\text{ V}$ $V_{BIAS} = 1.2\text{ V}$	$T_A = 25^{\circ}\text{C}$		14	24			
	$T_J = 125^{\circ}\text{C}$			30			
$V_{IN} = 0.8\text{ V}$ $V_{BIAS} = 1.2\text{ V}$	$T_A = 25^{\circ}\text{C}$		17	30			
	$T_J = 125^{\circ}\text{C}$			35			
R_{DIS}	Output discharge path	EN = low, NCP459		230	300	Ω	

TIMINGS

T_R	Output rise time From 10% to 90% of V_{OUT}	$V_{IN} = 5\text{ V}$ $C_{LOAD} = 1\ \mu\text{F}$, $R_{LOAD} = 25\ \Omega$	No cap on GATE pin		0.26		ms	
			Gate capacitor = 1 nF		1.5			
			Gate capacitor = 10 nF		15			
T_{en}	Enable time From En V_{ih} to 10% of V_{OUT}		Without Cgate		10		μs	
			With 1 nF on Gate		60		μs	
T_F	Fall Time. From 90% to 10% of V_{OUT}				50		μs	
T_{dis}	Disable time					75	μs	
T_R	Output rise time From 10% to 90% of V_{OUT}		$V_{IN} = 3.3\text{ V}$ $C_{LOAD} = 1\ \mu\text{F}$, $R_{LOAD} = 25\ \Omega$	No cap on GATE pin		0.25	0.5	ms
				Gate capacitor = 1 nF		1		
				Gate capacitor = 10 nF		10		
T_{en}	Enable time From En V_{ih} to 10% of V_{OUT}	Without Cgate, NCP459			20	50	μs	
		Without Cgate, NCP458R			90	150	μs	
		With 1 nF on Gate			114		μs	
T_F	Output fall time From 90% to 10% of V_{OUT}				60	120	μs	
T_R	Output rise time From 10% to 90% of V_{OUT}	$V_{IN} = 1.8\text{ V}$ $C_{LOAD} = 1\ \mu\text{F}$, $R_{LOAD} = 25\ \Omega$		No cap on GATE pin		0.12		ms
				Gate capacitor = 1 nF		0.6		
				Gate capacitor = 10 nF		5.5		
T_{en}	Enable time From En V_{ih} to 10% of V_{OUT}		Without Cgate		15		μs	
			With 1 nF on Gate		85		μs	
T_F	Output fall time From 90% to 10% of V_{OUT}				35		μs	

Product parametric performance is indicated in the Electrical Characteristics for the listed test conditions, unless otherwise noted. Product performance may not be indicated by the Electrical Characteristics if operated under different conditions.

7. Parameters are guaranteed for C_{LOAD} and R_{LOAD} connected to the OUT pin with respect to the ground

NCP458R, NCP459

ELECTRICAL CHARACTERISTICS Min & Max Limits apply for T_A between -40°C to $+85^{\circ}\text{C}$ for V_{IN} between 0.75 V and 5.5 V, and V_{BIAS} between 1.2 V and 5.5 V (Unless otherwise noted). Typical values are referenced to $T_A = +25^{\circ}\text{C}$, $V_{IN} = 3.3\text{ V}$ and $V_{BIAS} = 5\text{ V}$ (Unless otherwise noted).

Symbol	Parameter	Conditions	Min	Typ	Max	Unit
--------	-----------	------------	-----	-----	-----	------

TIMINGS

T_R	Output rise time From 10% to 90% of V_{OUT}	$V_{IN} = 1\text{ V}$ $C_{LOAD} = 1\ \mu\text{F}$, $R_{LOAD} = 25\ \Omega$	No cap on GATE pin		0.01	ms
			Gate capacitor = 1 nF		1	
			Gate capacitor = 10 nF		13	
T_{en}	Enable time From En V_{ih} to 10% of V_{OUT}	$V_{IN} = 1\text{ V}$ $C_{LOAD} = 1\ \mu\text{F}$, $R_{LOAD} = 25\ \Omega$	Without C_{gate}		10	μs
			With 1 nF on Gate		0.4	ms
T_F	Output fall time			20		μs

Logic

V_{IH}	High-level input voltage		0.9			V
V_{IL}	Low-level input voltage				0.4	V
R_{EN}	Pull down resistor		3		7	$\text{M}\Omega$

REVERSE CURRENT BLOCKING

V_{rev_thr}	Reverse threshold	$V_{OUT} - V_{IN}$		45		mV
V_{rev_hyst}	Reverse threshold hysteresis			60		mV
T_{rev}	Reverse comparator response time	$V_{OUT} - V_{in} > V_{rev_thr}$		2.5		μs

QUIESCENT CURRENT- NCP458R

I_{VBIAS}	V_{BIAS} Quiescent current	$V_{BIAS} = 3.3\text{ V}$, EN = high		1.5	6	μA
I_{INQ}	IN Quiescent current	EN = high		0.01	0.3	μA
I_{STBIN}	Standby current IN	EN = low, IN standby current, $V_{IN} = 3.3\text{ V}$, without discharge path.		0.01	0.3	μA
$I_{STDVbias}$	Standby current V_{BIAS}	$V_{BIAS} = 3.3\text{ V}$ EN = low		0.4	1.5	μA
I_{out_leak}	Output leakage current	IN connected to GND, $V_{OUT} = 5\text{ V}$		0.01	0.5	μA

QUIESCENT CURRENT - NCP459

I_{VBIAS}	V_{BIAS} Quiescent current	$V_{BIAS} = 3.3\text{ V}$, EN = high		1.3	5	μA
I_{INQ}	IN Quiescent current	EN = high		0.01	0.3	μA
I_{STBIN}	Standby current IN	EN = low, IN standby current, $V_{IN} = 3.3\text{ V}$, with discharge path. NCP459.		0.01	0.3	μA
$I_{STDVbias}$	Standby current V_{BIAS}	$V_{BIAS} = 3.3\text{ V}$ EN = low		0.4	1.5	μA

Product parametric performance is indicated in the Electrical Characteristics for the listed test conditions, unless otherwise noted. Product performance may not be indicated by the Electrical Characteristics if operated under different conditions.

7. Parameters are guaranteed for C_{LOAD} and R_{LOAD} connected to the OUT pin with respect to the ground

NCP458R, NCP459

TIMINGS

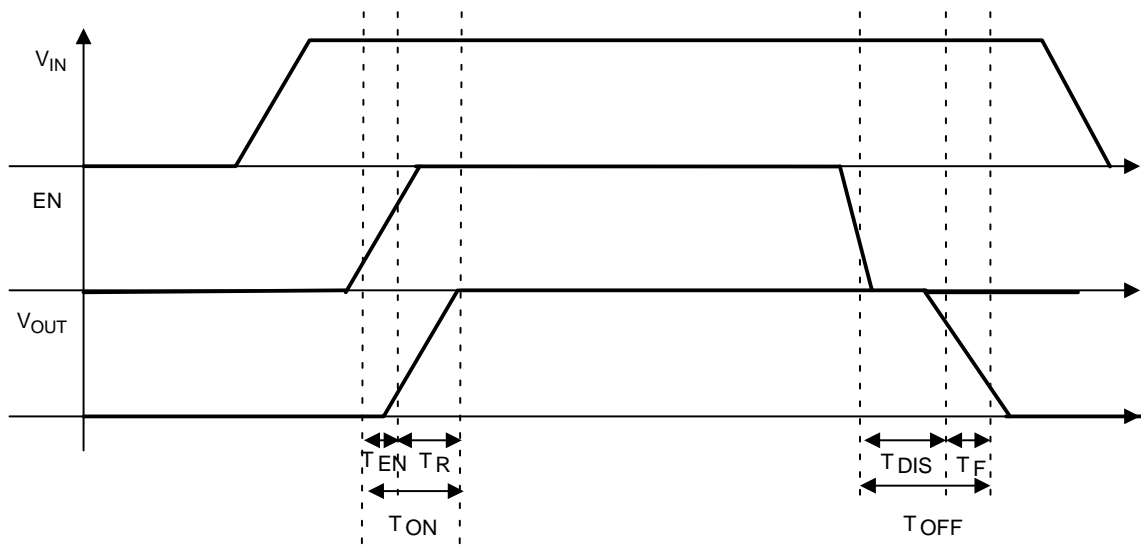

Figure 5. Enable, Rise and Fall Time

TYPICAL CHARACTERISTICS

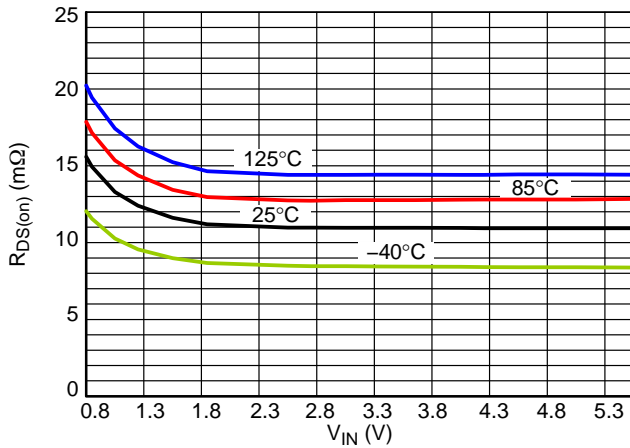

Figure 6. R_{DS(on)} (mΩ) vs V_{IN} (V), Over Temperature Range

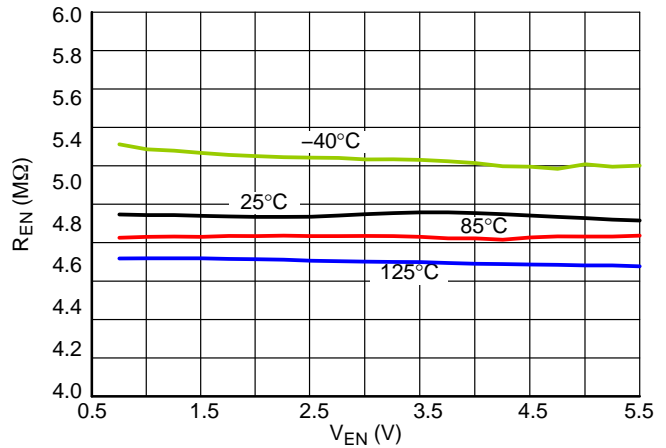

Figure 7. Pull Down Resistor (MΩ) vs V_{EN} (V), Over Temperature Range

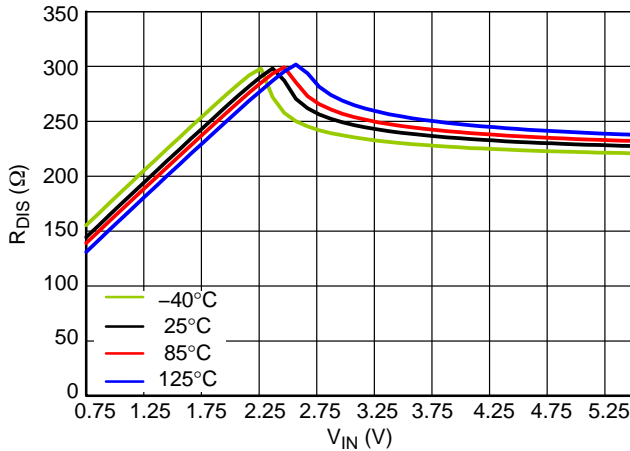

Figure 8. Discharge Resistor (Ω) vs V_{IN} (V), Over Temperature Range

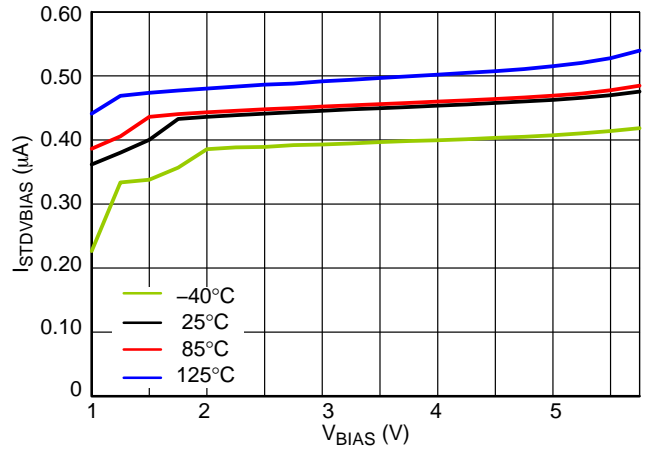

Figure 9. NCP458R Standby Current (μA) vs V_{BIAS} (V), Over Temperature Range

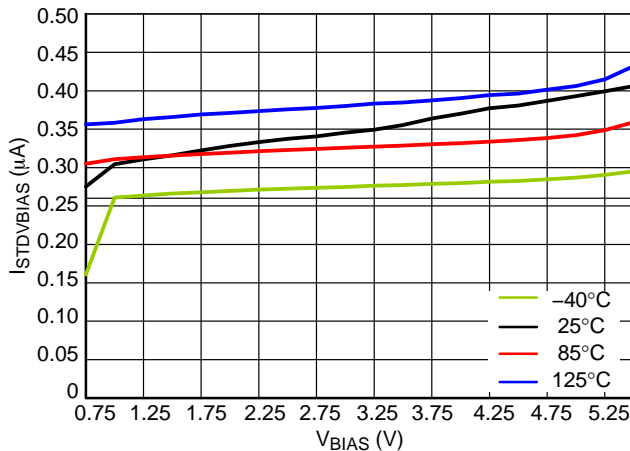

Figure 10. NCP459 Standby Current (μA) vs V_{BIAS} (V), Over Temperature Range

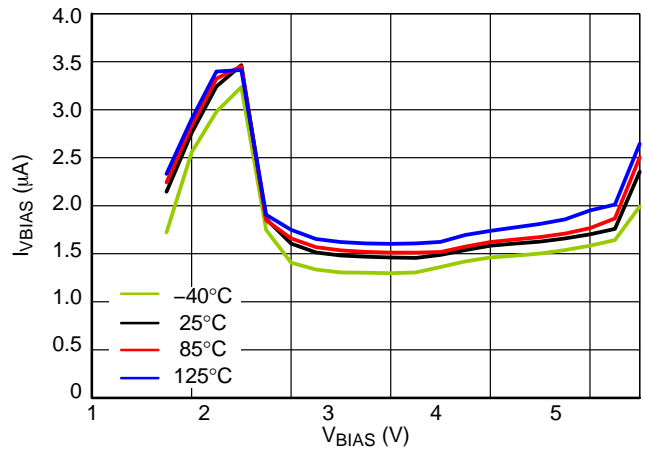

Figure 11. NCP458R Quiescent Current (μA) vs V_{BIAS} (V), Over Temperature Range

NCP458R, NCP459

TYPICAL CHARACTERISTICS

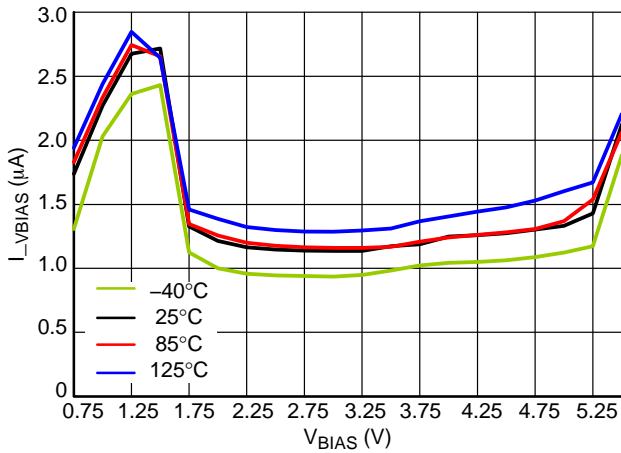

Figure 12. NCP459 Quiescent Current (μA) vs V_{BIAS} (V), Over Temperature Range

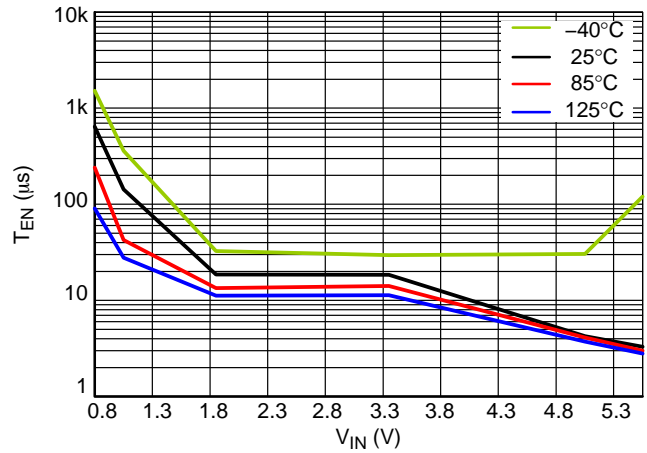

Figure 13. Enable Time (μs) vs V_{IN} (V), Over Temperature Range (without C_{gate})

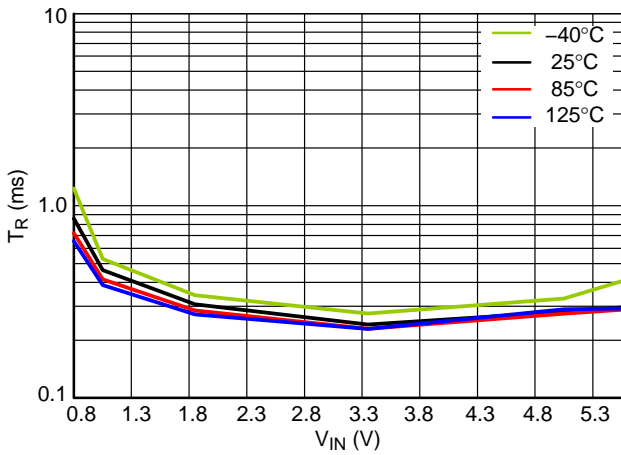

Figure 14. Rise Time (ms) vs V_{IN} (V), Over Temperature Range (without C_{gate})

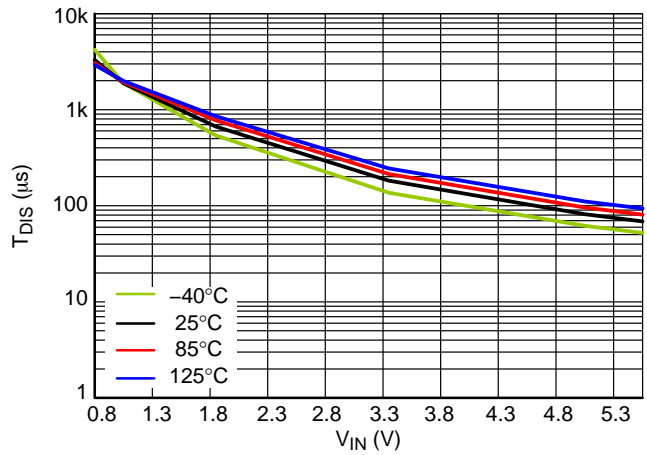

Figure 15. Disable Time (μs) vs V_{IN} (V), Over Temperature Range V_{BIAS} and V_{IN} Tied Together

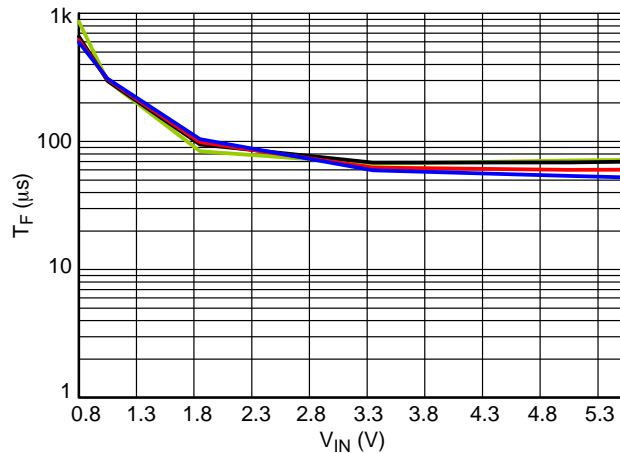

Figure 16. Fall Time (μs) vs V_{IN} (V), Over Temperature Range V_{BIAS} and V_{IN} Tied Together $R_{\text{load}} 25 \Omega$

NCP458R, NCP459

FUNCTIONAL DESCRIPTION

Overview

The NCP458R and NCP459 are high side N channel MOSFET power distribution switch designed to isolate ICs connected on the battery or DCDC supplies in order to save energy. The part can be used with a wide range of supply from 0.75 V to 5.5 V.

Enable Input

Enable pin is an active high. The path is opened when EN pin is tied low (disable), forcing NMOS switch off.

The IN/OUT path is activated with a minimum of $V_{BIAS\ min}$, $V_{in\ min}$ and EN forced to high level.

Auto Discharge (Optional – NCP459)

NMOS FET is placed between the output pin and GND, in order to discharge the application capacitor connected on OUT pin.

The auto-discharge is activated when EN pin is set to low level (disable state).

The discharge path (Pull down NMOS) stays activated as long as EN pin is set at low level.

In order to limit the current across the internal discharge Nmosfet, the typical value is set at R_{DIS} value.

Vbias Rail

The core of the IC is supplied thanks to Vbias supply rail (common +5 V, 3.3 V, 1.8 V, 1.2 V). Indeed, no current consumption is used on IN pin, allowing to improve power saving of the rail that must be isolated by the power switch.

If Vbias rail is not available or used, Vbias pin and Vin pin can be connected together as close as possible the DUT. A minimum of 1.2 V is necessary to control the IC.

Output rise time – Gate control

The NMOS is control with internal charge pump and driver. A minimum gate slew rate is internally set to avoid huge inrush current when EN is set from low to high. The default gate slew rate depends on Vin level. The higher Vin level, the longer rise time.

In addition, an external capacitor can be connected between Gate pin and GND in order to slow down the gate rising. See electrical table for more details.

Cin and Cout Capacitors

100 nF external capacitors must be connected as close as possible the DUT for noise immunity and better stability. In case of input hot plug (input voltage connected with fast slew rate – few μs – it's strongly recommended to avoid big capacitor connected on the input. That allows to avoid input over voltage transients.

Reverse Blocking Control (Optional NCP458R)

A reverse blocking control circuitry is embedded to eliminate leakages from OUT to IN in case of $V_{out} > V_{in}$.

A comparator measures the dropout voltage on the switch between OUT and IN and turn off the NMOS if this voltage exceeds specified reverse voltage.

NCP458R, NCP459

APPLICATION INFORMATION

Power Dissipation

Main contributor in term of junction temperature is the power dissipation of the power MOSFET. Assuming this, the power dissipation and the junction temperature in normal mode can be calculated with the following equations:

$$P_D = R_{DS(on)} \times (I_{OUT})^2 \quad (\text{eq. 1})$$

- P_D = Power dissipation (W)
 - $R_{DS(on)}$ = Power MOSFET on resistance (Ω)
 - I_{OUT} = Output current (A)
- $$T_J = P_D \times R_{\theta JA} + T_A \quad (\text{eq. 2})$$

- T_J = Junction temperature ($^{\circ}\text{C}$)
- $R_{\theta JA}$ = Package thermal resistance ($^{\circ}\text{C}/\text{W}$)
- T_A = Ambient temperature ($^{\circ}\text{C}$)

Demoboard

The NCP458R and NCP459 integrate a 4 A rated NMOS FET, and the PCB rules must be respected to properly evacuate the heat out of the silicon.

The package is a CSP and due to the low thermal resistance of the silicon, all the balls can be used to improved power dissipation. Indeed, even if the power crosses the IN / OUT pins only, all the balls around this power area should be connected to the larger PCB area.

In the below PCB example (application demonstration board), all the PCB areas connected to 6 balls are enlarged. In addition vias are connected to bottom side with exactly same form factor of the other PCB side.

Additional improvements can be done also by using more copper thickness and the thinner epoxy as possible.

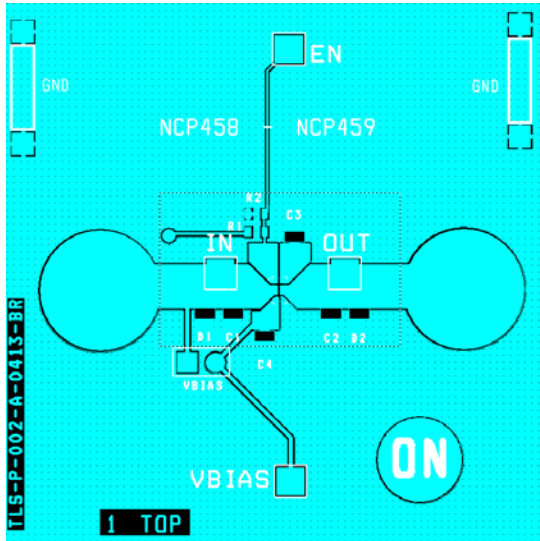

Figure 17. Demonstration Board (top view)

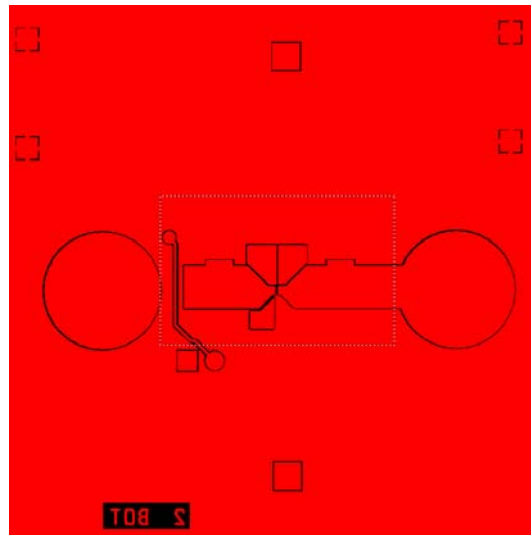

Figure 18. Demonstration Board (bottom view)

NCP458R, NCP459

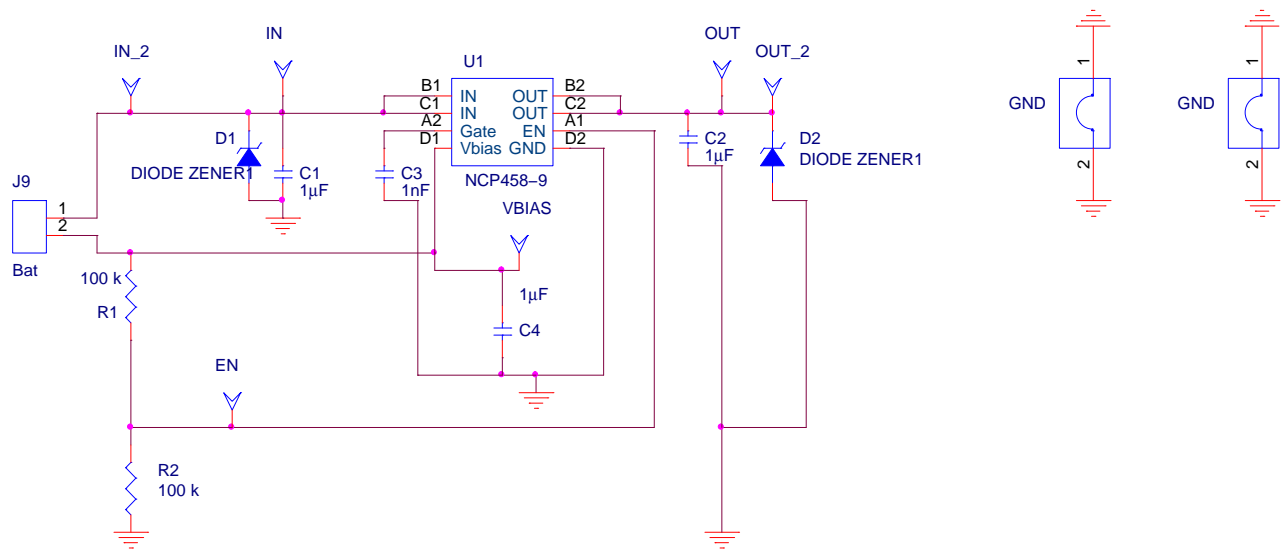

Figure 19. Demonstration Board Schematic

BILL OF MATERIAL TABLE

Quantity	Reference schem	Part description	Part number	Manufacturer
2	IN, OUT	Socket, 4mm, metal, PK5	B010	HIRSCHMANN
4	IN_2, OUT_2, VBIAS, EN	HEADER200	2.54 mm, 77313-101-06LF	FC
1	J9 (Bat)	HEADER200-2	2.54 mm, 77313-101-06LF	FC
3	C1, C2, C4	1uF	GRM155R70J105KA12#	Murata
1	C3	1nF, Not mounted	GRM188R60J102ME47#	Murata
1	D1, D2	TVS	ESD9x	ON Semiconductor
2	GND2, GND	GND JUMPER	D3082F05	Harvin
2	R2, R3	Resistor 100k 0603	MC 0.063 0603 1% 100K	MULTICOMP
1	U1	Load switch	NCP458 - 459	ON Semiconductor

ORDERING INFORMATION

Device	Options	Marking	Package	Shipping†
NCP458RFCT2G	Reverse Voltage Protection	458RdYWW	WLCSP 1 x 2 mm (Pb-Free)	3000 Tape / Reel
NCP458RFCCT2G	Reverse Voltage Protection, Die Coating	458RCdYWW	WLCSP 1 x 2 mm (Pb-Free)	3000 Tape / Reel
NCP459FCT2G	Discharge Path	459dYWW	WLCSP 1 x 2 mm (Pb-Free)	3000 Tape / Reel

†For information on tape and reel specifications, including part orientation and tape sizes, please refer to our Tape and Reel Packaging Specifications Brochure, BRD8011/D.

MECHANICAL CASE OUTLINE

PACKAGE DIMENSIONS

ON Semiconductor®



SCALE 4:1

WLCSP8, 2.0x1.0
CASE 567HD
ISSUE O

DATE 26 APR 2013

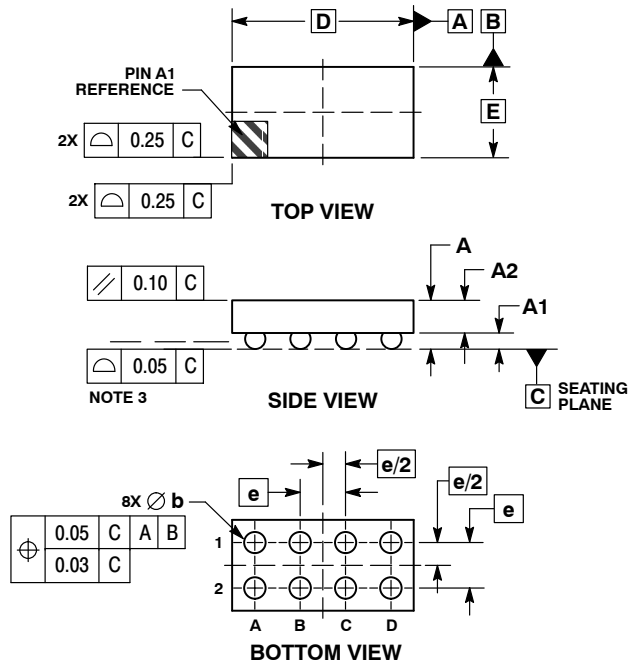

- NOTES:
1. DIMENSIONING AND TOLERANCING PER ASME Y14.5M, 1994.
 2. CONTROLLING DIMENSION: MILLIMETERS.
 3. COPLANARITY APPLIES TO THE SPHERICAL CROWNS OF THE SOLDER BALLS.

DIM	MILLIMETERS	
	MIN	MAX
A	---	0.66
A1	0.21	0.27
A2	0.36 REF	
b	0.29	0.34
D	2.00 BSC	
E	1.00 BSC	
e	0.50 BSC	

GENERIC MARKING DIAGRAM*

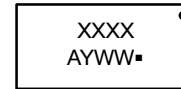

- A = Assembly Location
- Y = Year
- WW = Work Week
- = Pb-Free Package

*This information is generic. Please refer to device data sheet for actual part marking. Pb-Free indicator, "G" or microdot "▪", may or may not be present.

RECOMMENDED SOLDERING FOOTPRINT*

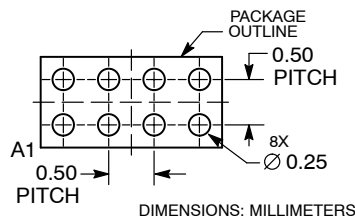

*For additional information on our Pb-Free strategy and soldering details, please download the ON Semiconductor Soldering and Mounting Techniques Reference Manual, SOLDERRM/D.

DOCUMENT NUMBER:	98AON89060E	Electronic versions are uncontrolled except when accessed directly from the Document Repository. Printed versions are uncontrolled except when stamped "CONTROLLED COPY" in red.
DESCRIPTION:	WLCSP8, 2.0X1.0	PAGE 1 OF 1

ON Semiconductor and are trademarks of Semiconductor Components Industries, LLC dba ON Semiconductor or its subsidiaries in the United States and/or other countries. ON Semiconductor reserves the right to make changes without further notice to any products herein. ON Semiconductor makes no warranty, representation or guarantee regarding the suitability of its products for any particular purpose, nor does ON Semiconductor assume any liability arising out of the application or use of any product or circuit, and specifically disclaims any and all liability, including without limitation special, consequential or incidental damages. ON Semiconductor does not convey any license under its patent rights nor the rights of others.

ON Semiconductor and  are trademarks of Semiconductor Components Industries, LLC dba ON Semiconductor or its subsidiaries in the United States and/or other countries. ON Semiconductor owns the rights to a number of patents, trademarks, copyrights, trade secrets, and other intellectual property. A listing of ON Semiconductor's product/patent coverage may be accessed at www.onsemi.com/site/pdf/Patent-Marking.pdf. ON Semiconductor reserves the right to make changes without further notice to any products herein. ON Semiconductor makes no warranty, representation or guarantee regarding the suitability of its products for any particular purpose, nor does ON Semiconductor assume any liability arising out of the application or use of any product or circuit, and specifically disclaims any and all liability, including without limitation special, consequential or incidental damages. Buyer is responsible for its products and applications using ON Semiconductor products, including compliance with all laws, regulations and safety requirements or standards, regardless of any support or applications information provided by ON Semiconductor. "Typical" parameters which may be provided in ON Semiconductor data sheets and/or specifications can and do vary in different applications and actual performance may vary over time. All operating parameters, including "Typicals" must be validated for each customer application by customer's technical experts. ON Semiconductor does not convey any license under its patent rights nor the rights of others. ON Semiconductor products are not designed, intended, or authorized for use as a critical component in life support systems or any FDA Class 3 medical devices or medical devices with a same or similar classification in a foreign jurisdiction or any devices intended for implantation in the human body. Should Buyer purchase or use ON Semiconductor products for any such unintended or unauthorized application, Buyer shall indemnify and hold ON Semiconductor and its officers, employees, subsidiaries, affiliates, and distributors harmless against all claims, costs, damages, and expenses, and reasonable attorney fees arising out of, directly or indirectly, any claim of personal injury or death associated with such unintended or unauthorized use, even if such claim alleges that ON Semiconductor was negligent regarding the design or manufacture of the part. ON Semiconductor is an Equal Opportunity/Affirmative Action Employer. This literature is subject to all applicable copyright laws and is not for resale in any manner.

PUBLICATION ORDERING INFORMATION

LITERATURE FULFILLMENT:

Email Requests to: orderlit@onsemi.com

ON Semiconductor Website: www.onsemi.com

TECHNICAL SUPPORT

North American Technical Support:
Voice Mail: 1 800-282-9855 Toll Free USA/Canada
Phone: 011 421 33 790 2910

Europe, Middle East and Africa Technical Support:

Phone: 00421 33 790 2910

For additional information, please contact your local Sales Representative

X-ON Electronics

Largest Supplier of Electrical and Electronic Components

Click to view similar products for [Power Switch ICs - Power Distribution](#) *category:*

Click to view products by [ON Semiconductor](#) *manufacturer:*

Other Similar products are found below :

[TCK111G,LF\(S\)](#) [FPF1018](#) [DS1222](#) [TCK2065G,LF](#) [SZNCP3712ASNT3G](#) [MIC2033-05BYMT-T5](#) [MIC2033-12AYMT-T5](#) [MIC2033-05BYM6-T5](#) [SLG5NT1437VTR](#) [SZNCP3712ASNT1G](#) [DML1008LDS-7](#) [KTS1670EDA-TR](#) [KTS1640QGDV-TR](#) [KTS1641QGDV-TR](#) [NCV459MNWTBG](#) [FPF2260ATMX](#) [U6513A](#) [MIC2012YM-TR](#) [NCP45780IMN24RTWG](#) [MAX14919ATP+](#) [MC33882PEP](#) [TPS2104DBVR](#) [MIC2098-1YMT-TR](#) [MIC94062YMT TR](#) [MP6231DN-LF](#) [MIC2015-1.2YM6 TR](#) [MIC2075-2YM](#) [MIC94068YML-TR](#) [SIP32461DB-T2-GE1](#) [NCP335FCT2G](#) [TCK105G,LF\(S\)](#) [AP2411S-13](#) [AP2191DWG-7](#) [AP2151DSG-13](#) [MIC94094YC6-TR](#) [MIC94093YC6-TR](#) [MIC94064YC6-TR](#) [MIC2505-1YM](#) [MIC94305YMT-TR](#) [MIC94085YFT-TR](#) [MIC94081YFT-TR](#) [MIC94042YFL-TR](#) [MIC94041YFL-TR](#) [MIC2005-1.2YM6-TR](#) [TPS2032QDRQ1](#) [NCP333FCT2G](#) [BTS3050TFATMA1](#) [NCP331SNT1G](#) [TPS2092DR](#) [TPS2063DR](#)