

NCP4810

X2 Capacitors Discharger

The NCP4810 is a HV switch suitable for implementation of the X2 capacitor discharge function in applications with extremely low standby consumption requirements. It contains two high voltage MOSFETs with 700 V peak capabilities that can be connected directly to AC line voltage. Implementing this IC helps to design optimized EMI filter with appropriate X2 capacitor and reduced EMI coil volume and losses.

Features

- Build-in 700 V MOSFET
- Minimum Discharge Capability 0.85 mA
- Self Consumption Below 11 mW @ 700 V
- NoV_{CC} Necessary
- Compact SOIC-8 Package
- -40°C to + 125°C Operating Temperature Range
- This is a Pb-Free Device

Typical Applications

- Auxiliary Power Supply
- AC-DC Adapter
- Standby Power Supply
- Offline Battery Charger



ON Semiconductor®

www.onsemi.com

MARKING DIAGRAM



SOIC-8
D SUFFIX
CASE 751

A = Assembly Location
L = Wafer Lot
Y = Year
W = Work Week
X = Assembly Lot
G = Pb-Free Package

PINOUT

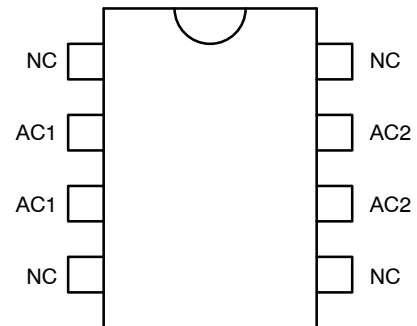

ORDERING INFORMATION

Device	Package	Shipping†
NCP4810DR2G	SOIC-8 (Pb-Free)	2500 / Tape & Reel

†For information on tape and reel specifications, including part orientation and tape sizes, please refer to our Tape and Reel Packaging Specifications Brochure, BRD8011/D.

NCP4810

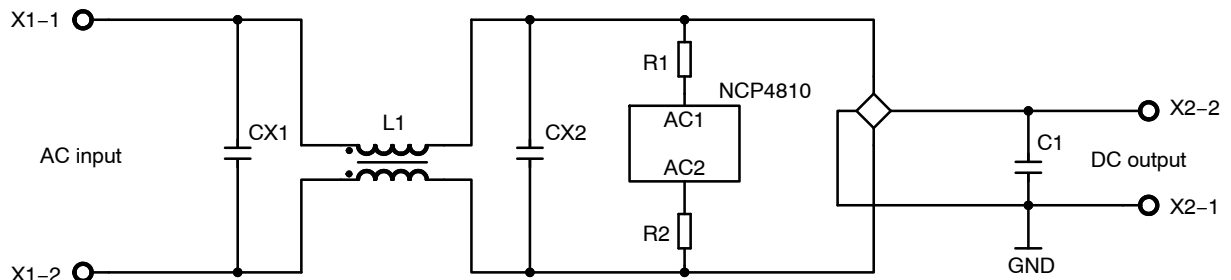

Figure 1. Typical Application Example of the X2 Discharger

PIN FUNCTION DESCRIPTION

Pin N°	Pin Name	Function	Pin Description
1	NC	Not connected	-
2	AC1	Alternate Current 1	Terminal for connections AC line
3	AC1	Alternate Current 1	Terminal for connections AC line
4	NC	Not connected	-
5	NC	Not connected	-
6	AC2	Alternate Current 2	Terminal for connections AC line
7	AC2	Alternate Current 2	Terminal for connections AC line
8	NC	Not connected	-

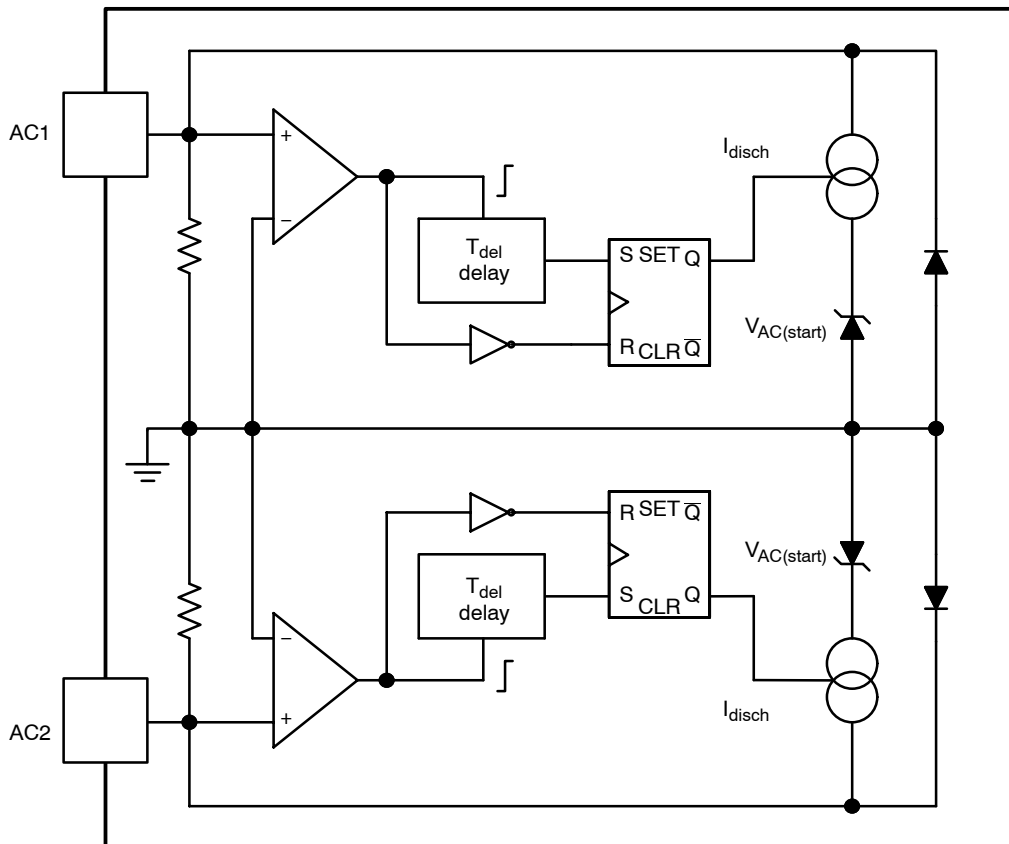

Figure 2. Simplified Circuit Architecture

NCP4810

MAXIMUM RATINGS

Rating	Symbol	Value	Unit
AC1 pin Voltage related to AC2 pin	V_{HV}	-700 to 700	V
Thermal Resistance, Junction-to-Air (50 mm ² x 35 μm Cu)	$R_{\theta J-A}$	162	°C/W
Junction Temperature	T_J	-40 to +150	°C
Storage Temperature Range	T_{stg}	-60 to +150	°C
ESD Capability, HBM model per JEDEC standard JESD22, Method A114E	$V_{ESD-HBM}$	4	kV
ESD Capability, Machine Model per JEDEC standard JESD22, Method A115A	V_{ESD-MM}	600	V

Stresses exceeding those listed in the Maximum Ratings table may damage the device. If any of these limits are exceeded, device functionality should not be assumed, damage may occur and reliability may be affected.

1. The latchup tests were not provided on this device because of two function pins only.

ELECTRICAL CHARACTERISTICS

(for typical values $T_J = 25^\circ\text{C}$, for min/max values $T_J = -40^\circ\text{C}$ to $+125^\circ\text{C}$, unless otherwise noted.)

Parameter	Conditions	Symbol	Min	Typ	Max	Unit
-----------	------------	--------	-----	-----	-----	------

HV PIN

Discharge current capability	$V_{AC} = 400 \text{ Vdc}$	I_{disch}	0.85	-	-	mA
Minimum HV voltage	$I_{AC} = I_{disch} * 0.95$	$V_{AC(start)}$	-	-	29	Vdc
I_{HV} or $I_{HV(start)}$ leakage current	$V_{AC} = 700 \text{ Vdc}$	$I_{AC(leak)}$	-	7	15	μA

INTERNAL TIMER

Internal timer	-	T_{del}	15	-	90	ms
----------------	---	-----------	----	---	----	----

NCP4810

TYPICAL CHARACTERISTICS

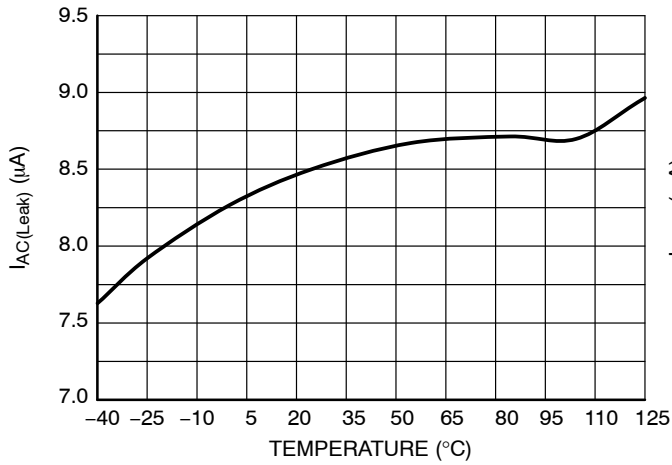

Figure 3. I_{HV} or $I_{HV(start)}$ Leakage Current, $I_{AC(Leak)}$

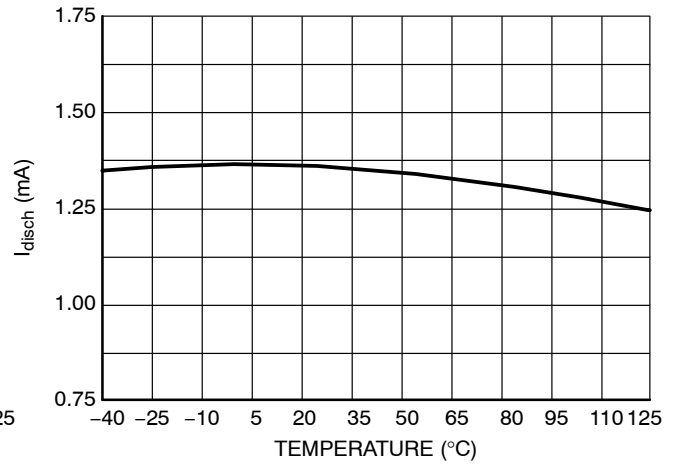

Figure 4. Discharge Current Capability, I_{disch}

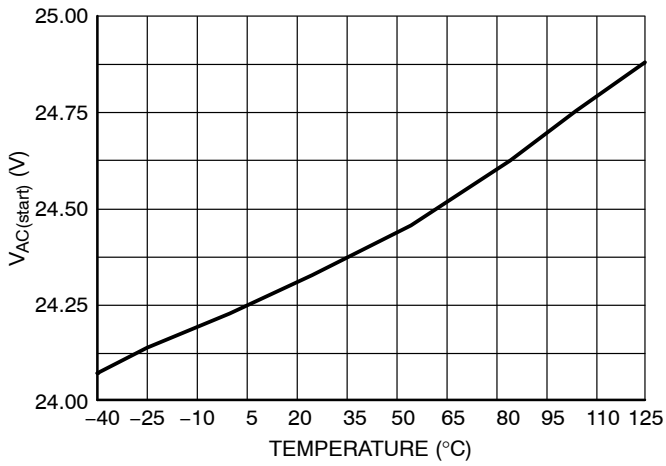

Figure 5. Minimum HV Voltage, $V_{AC(start)}$

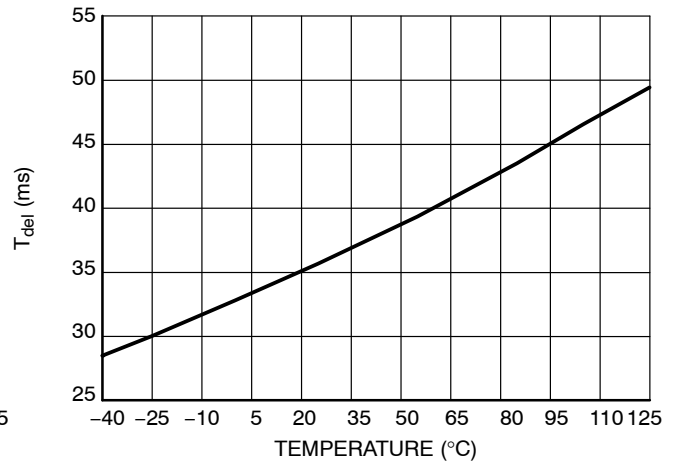

Figure 6. Internal Timer, T_{del}

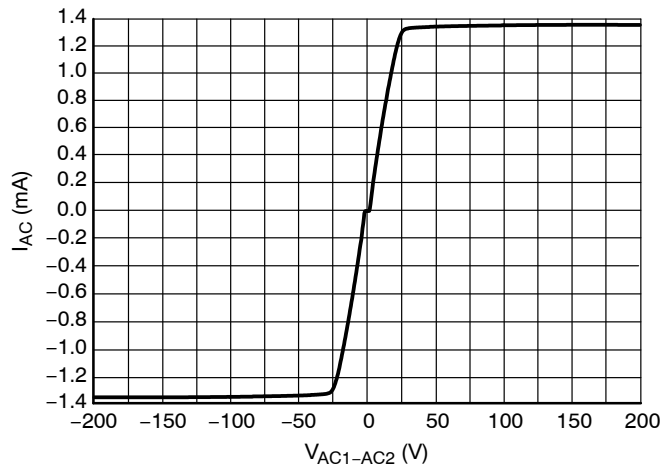

Figure 7. Typical Behavior of Discharge Current versus DC Voltage between AC pins

NCP4810

Function Description:

The input sinusoidal voltage resets the relevant internal timer by transitioning across zero level at each its half wave. If no zero cross is detected, the internal timer expires and the appropriate current sink is turned on. This discharging path (the current sink and opposite diode) is established until the X2 capacitors are discharged (the input terminal voltage V_{AC} drops to zero) or the input AC voltage is restored by re-plugging the mains. The minimum discharge voltage is defined by $V_{AC(start)}$. Low $V_{AC(start)}$ allows to use serial resistors to distribute loss during discharging process. The recommended resistors values (R1 and R2) for any X2 capacitor are mentioned in Table 1. Every possibility of IC

function refer to the input voltage behavior is described on Figure 8.

Table 1. RECOMMENDED SERIES RESISTORS VALUES

X2 Capacitance	Total Series Resistance (R1 + R2)
≤ 500 nF	1.5 M Ω
750 nF	1.02 M Ω
1 μ F	780 k Ω
1.5 μ F	480 k Ω
2 μ F	360 k Ω

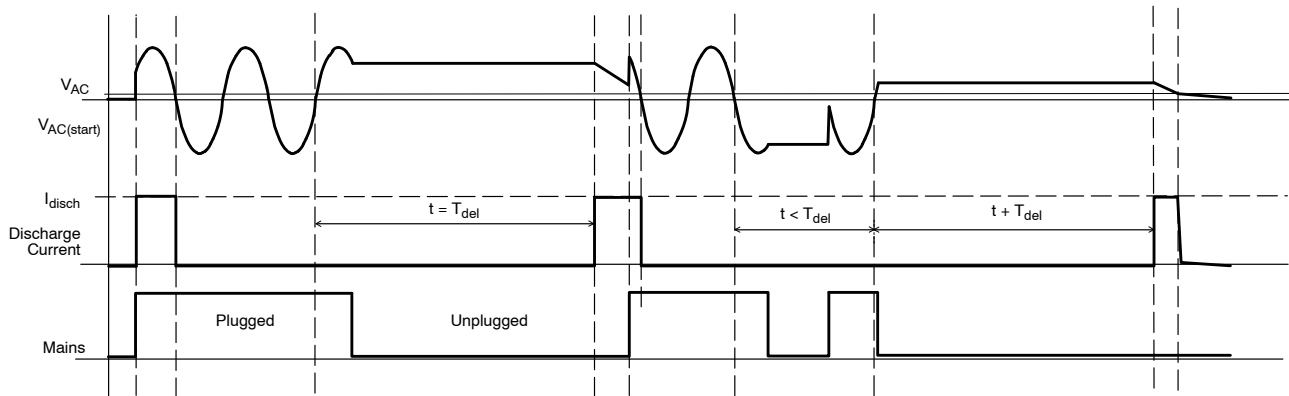
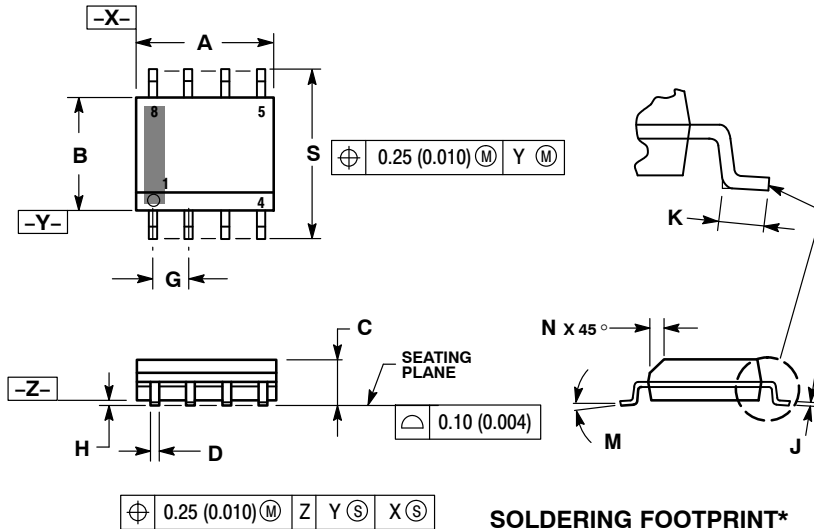

Figure 8. Function Description

NCP4810

PACKAGE DIMENSIONS

SOIC-8 NB CASE 751-07 ISSUE AK



NOTES:

1. DIMENSIONING AND TOLERANCING PER ANSI Y14.5M, 1982.
2. CONTROLLING DIMENSION: MILLIMETER.
3. DIMENSION A AND B DO NOT INCLUDE MOLD PROTRUSION.
4. MAXIMUM MOLD PROTRUSION 0.15 (0.006) PER SIDE.
5. DIMENSION D DOES NOT INCLUDE DAMBAR PROTRUSION. ALLOWABLE DAMBAR PROTRUSION SHALL BE 0.127 (0.005) TOTAL IN EXCESS OF THE D DIMENSION AT MAXIMUM MATERIAL CONDITION.
6. 751-01 THRU 751-06 ARE OBSOLETE. NEW STANDARD IS 751-07.

DIM	MILLIMETERS		INCHES	
	MIN	MAX	MIN	MAX
A	4.80	5.00	0.189	0.197
B	3.80	4.00	0.150	0.157
C	1.35	1.75	0.053	0.069
D	0.33	0.51	0.013	0.020
G	1.27 BSC		0.050 BSC	
H	0.10	0.25	0.004	0.010
J	0.19	0.25	0.007	0.010
K	0.40	1.27	0.016	0.050
M	0°	8°	0°	8°
N	0.25	0.50	0.010	0.020
S	5.80	6.20	0.228	0.244

SOLDERING FOOTPRINT*

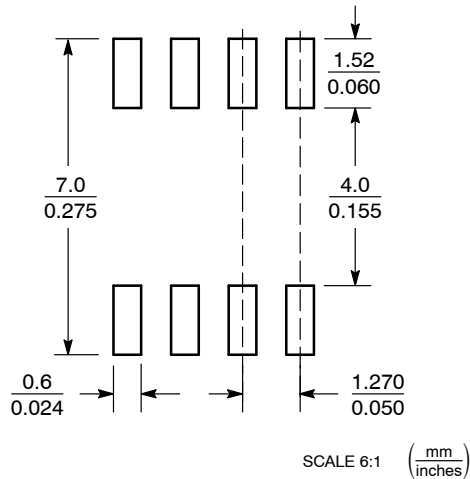

*For additional information on our Pb-Free strategy and soldering details, please download the ON Semiconductor Soldering and Mounting Techniques Reference Manual, SOLDERRM/D.

ON Semiconductor and the are registered trademarks of Semiconductor Components Industries, LLC (SCILLC) or its subsidiaries in the United States and/or other countries. SCILLC owns the rights to a number of patents, trademarks, copyrights, trade secrets, and other intellectual property. A listing of SCILLC's product/patent coverage may be accessed at www.onsemi.com/site/pdf/Patent-Marking.pdf. SCILLC reserves the right to make changes without further notice to any products herein. SCILLC makes no warranty, representation or guarantee regarding the suitability of its products for any particular purpose, nor does SCILLC assume any liability arising out of the application or use of any product or circuit, and specifically disclaims any and all liability, including without limitation special, consequential or incidental damages. "Typical" parameters which may be provided in SCILLC data sheets and/or specifications can and do vary in different applications and actual performance may vary over time. All operating parameters, including "Typicals" must be validated for each customer application by customer's technical experts. SCILLC does not convey any license under its patent rights nor the rights of others. SCILLC products are not designed, intended, or authorized for use as components in systems intended for surgical implant into the body, or other applications intended to support or sustain life, or for any other application in which the failure of the SCILLC product could create a situation where personal injury or death may occur. Should Buyer purchase or use SCILLC products for any such unintended or unauthorized application, Buyer shall indemnify and hold SCILLC and its officers, employees, subsidiaries, affiliates, and distributors harmless against all claims, costs, damages, and expenses, and reasonable attorney fees arising out of, directly or indirectly, any claim of personal injury or death associated with such unintended or unauthorized use, even if such claim alleges that SCILLC was negligent regarding the design or manufacture of the part. SCILLC is an Equal Opportunity/Affirmative Action Employer. This literature is subject to all applicable copyright laws and is not for resale in any manner.

PUBLICATION ORDERING INFORMATION

LITERATURE FULFILLMENT:
Literature Distribution Center for ON Semiconductor
19521 E. 32nd Pkwy, Aurora, Colorado 80011 USA
Phone: 303-675-2175 or 800-344-3860 Toll Free USA/Canada
Fax: 303-675-2176 or 800-344-3867 Toll Free USA/Canada
Email: orderlit@onsemi.com

N. American Technical Support: 800-282-9855 Toll Free USA/Canada
Europe, Middle East and Africa Technical Support:
Phone: 421 33 790 2910
Japan Customer Focus Center
Phone: 81-3-5817-1050

ON Semiconductor Website: www.onsemi.com
Order Literature: <http://www.onsemi.com/orderlit>

For additional information, please contact your local Sales Representative

X-ON Electronics

Largest Supplier of Electrical and Electronic Components

Click to view similar products for [Power Management Specialised - PMIC category:](#)

Click to view products by [ON Semiconductor manufacturer:](#)

Other Similar products are found below :

[LV5686PVC-XH](#) [FAN7710VN](#) [NCP391FCALT2G](#) [SLG7NT4081VTR](#) [SLG7NT4192VTR](#) [AP4313UKTR-G1](#) [AS3729B-BWLM](#)
[MB39C831QN-G-EFE2](#) [MAX4940MB](#) [LV56841PVD-XH](#) [MAX77686EWE+T](#) [AP4306BUKTR-G1](#) [MIC5164YMM](#) [PT8A3252WE](#)
[NCP392CSFCCT1G](#) [TEA1998TS/1H](#) [PT8A3284WE](#) [PI3VST01ZEEX](#) [PI5USB1458AZAEX](#) [PI5USB1468AZAEX](#) [MCP16502TAC-E/S8B](#)
[MCP16502TAE-E/S8B](#) [MCP16502TAA-E/S8B](#) [MCP16502TAB-E/S8B](#) [TCKE712BNL,RF](#) [ISL91211AIKZT7AR5874](#)
[ISL91211BIKZT7AR5878](#) [MAX17506EVKITBE#](#) [MCP16501TC-E/RMB](#) [ISL91212AIIZ-TR5770](#) [ISL91212BIIZ-TR5775](#) [CPX200D](#) [AX-](#)
[3005D-3](#) [TP-1303](#) [TP-1305](#) [TP-1603](#) [TP-2305](#) [TP-30102](#) [TP-4503N](#) [MIC5167YML-TR](#) [LPTM21-1AFTG237C](#) [MPS-3003L-3](#) [MPS-3005D](#)
[SPD-3606](#) [STLUX383A](#) [TP-60052](#) [ADN8834ACBZ-R7](#) [LM26480SQ-AA/NOPB](#) [LM81BIMTX-3/NOPB](#) [LM81CIMT-3/NOPB](#)