

NCP6924

6 Channels Power Management IC (PMIC) with 2 DC-DC Converters and 4 LDOs

Product Overview

For complete documentation, see the data sheet.

The NCP6924 is part of the ON Semiconductor mini-power management IC family. It is optimized to supply battery powered portable application subsystems such as camera modules, microprocessors or any peripherals. This device integrates two high efficiency 1000 mA step-down DC to DC converters with DVS (Dynamic Voltage Scaling) and four low dropout (LDO) voltage regulators in WLCSP-30 2.46 x 2.06mm package.



Features

- Very small package 2.46 x 2.06 mm
- Ultra low quiescent current (105 uA typ)
- I2C accessible prior enabling device allowing to change settings before powering up the system
- Two DC-DC converters, efficiency 95%, programmable output voltage from 0.6 V to 3.3 V by 12.5 mV steps, 1000 mA output current capability
- Four low noise, low dropout regulators, programmable output voltage from 1.0 V to 3.3 V by 50 mV steps, 2 x 150 mA and 2 x 300mA output current capability, 50 uVrms typical low output noise

Applications

- Battery powered applications power management
- Power supply for processors with low core voltage
- Camera modules
- Peripheral sub-systems
- USB powered devices

Benefits

- Reduce PCB space
- Save battery life
- Offer design flexibility

End Products

- Smartphones
- Tablets
- Wearable devices
- MP3 players

Application Diagram

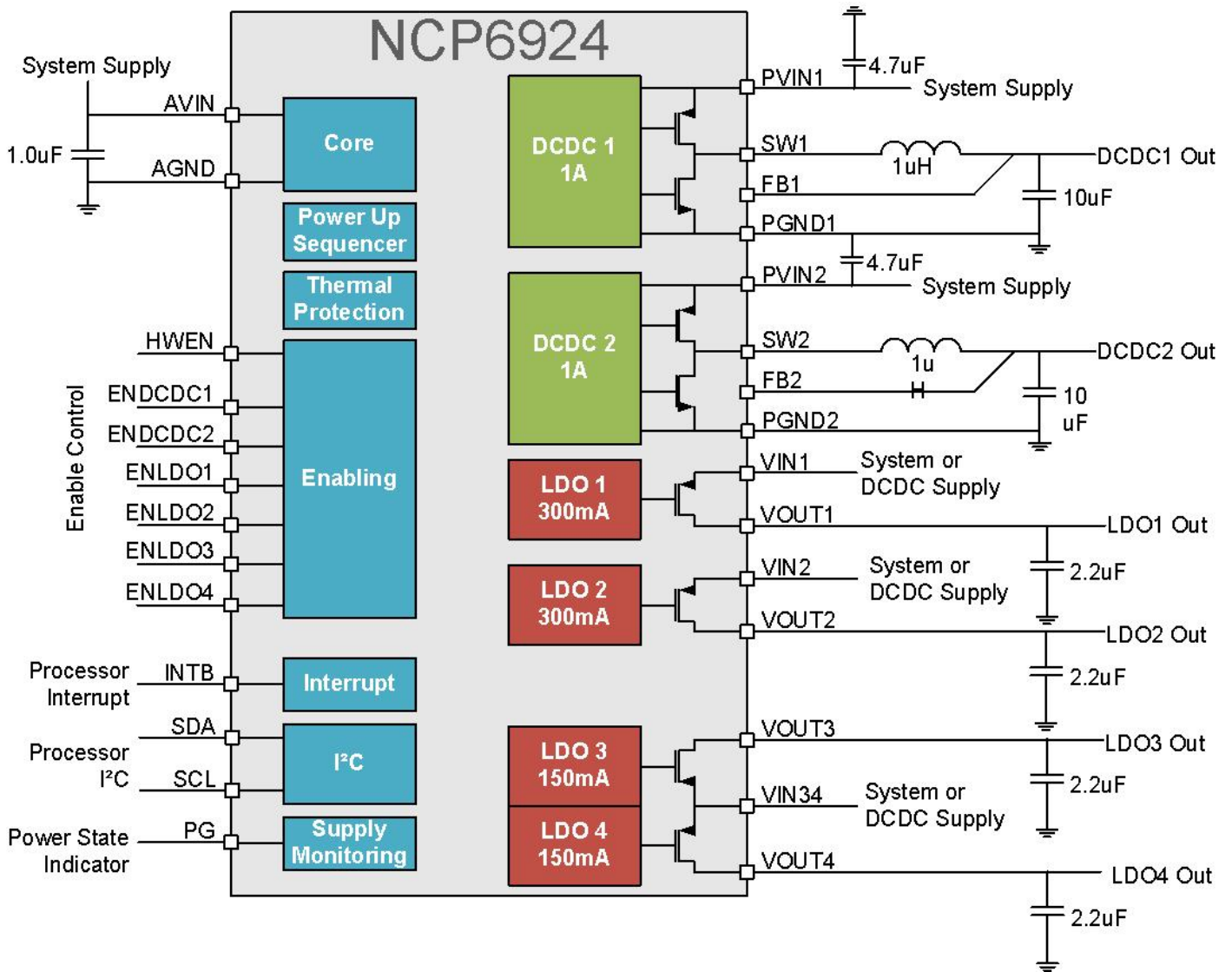

X-ON Electronics

Largest Supplier of Electrical and Electronic Components

Click to view similar products for [Power Management Specialised - PMIC category:](#)

Click to view products by [ON Semiconductor manufacturer:](#)

Other Similar products are found below :

[LV5686PVC-XH](#) [FAN7710VN](#) [NCP391FCALT2G](#) [SLG7NT4081VTR](#) [SLG7NT4192VTR](#) [AP4313UKTR-G1](#) [AS3729B-BWLM](#)
[MB39C831QN-G-EFE2](#) [MAX4940MB](#) [LV56841PVD-XH](#) [MAX77686EWE+T](#) [AP4306BUKTR-G1](#) [MIC5164YMM](#) [PT8A3252WE](#)
[NCP392CSFCCT1G](#) [TEA1998TS/1H](#) [PT8A3284WE](#) [PI3VST01ZEEX](#) [PI5USB1458AZAEX](#) [PI5USB1468AZAEX](#) [MCP16502TAC-E/S8B](#)
[MCP16502TAE-E/S8B](#) [MCP16502TAA-E/S8B](#) [MCP16502TAB-E/S8B](#) [TCKE712BNL,RF](#) [ISL91211AIKZT7AR5874](#)
[ISL91211BIKZT7AR5878](#) [MAX17506EVKITBE#](#) [MCP16501TC-E/RMB](#) [ISL91212AIIZ-TR5770](#) [ISL91212BIIZ-TR5775](#) [CPX200D](#) [AX-](#)
[3005D-3](#) [TP-1303](#) [TP-1305](#) [TP-1603](#) [TP-2305](#) [TP-30102](#) [TP-4503N](#) [MIC5167YML-TR](#) [LPTM21-1AFTG237C](#) [MPS-3003L-3](#) [MPS-3005D](#)
[SPD-3606](#) [STLUX383A](#) [TP-60052](#) [ADN8834ACBZ-R7](#) [LM26480SQ-AA/NOPB](#) [LM81BIMTX-3/NOPB](#) [LM81CIMT-3/NOPB](#)