

NCV7684

12 Channels 60 mA LED Linear Current Driver I²C Controllable for Automotive Applications

The NCV7684 consists of twelve linear programmable constant current sources. The part is designed for use in the regulation and control of LED for automotive applications. The NCV7684 allows 128 different current levels adjustable with pulse width modulation (PWM) programmable via I²C serial interface. The device can be used with micro-controller applications using the I²C bus or in stand-alone applications where a choice could be done in between 2 different configuration settings. The IC also provides 3.3 V voltage reference to the application for loads up to 1 mA.

LED brightness level is easily programmed using an external resistor. Each channel has an internal circuitry to detect open-load conditions with an optional auto-recovery mode. If one driver is in open-load condition, all other channels could be turned off according to the programmable bit setting.

The device is available in small body size SSOP24-EP package.

Features

- 12 programmable Current Sources Up to 60 mA
- Common PWM Gain Control via I²C
- On-chip 125, 250, or 500 Hz PWM
- Open LED String Diagnostic
- Low Dropout Operation for Pre-Regulator Applications
- Single Resistor for Current Set Point
- Voltage Reference 3.3 V / 1 mA
- 8 bits I²C Interface with CRC8 Error Detection
- OTP Bank for Stand-Alone Operation (2 Configurations)
- Detection and Protection Against Open Load and Under-Voltage
- Over Temperature Detection and Protection
- Low Emission with Spread Spectrum Oscillator
- AEC Q100 Qualified
- SSOP24-EP Packaging
- This is a Pb-Free Device

Applications

- Dashboard Applications
- Rear Combination Lamps (RCL)
- Daytime Running Lights (DRL)
- Fog Lights
- Center High Mounted Stop Lamps (CHMSL) Arrays
- Turn Signal and other Externally Modulated Applications



ON Semiconductor®

www.onsemi.com

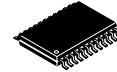

SSOP24 NB EP
CASE 940AP

MARKING DIAGRAM

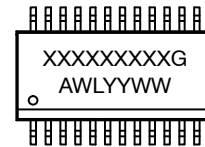

XXXX = Specific Device Code
A = Assembly Location
WL = Wafer Lot
YY = Year
WW = Work Week
G = Pb-Free Package

(Note: Microdot may be in either location)

ORDERING INFORMATION

Device	Package	Shipping†
NCV7684DQR2G	SSOP24-EP (Pb-Free)	2500 / Tape & Reel

†For information on tape and reel specifications, including part orientation and tape sizes, please refer to our Tape and Reel Packaging Specification Brochure, BRD8011/D.

NCV7684

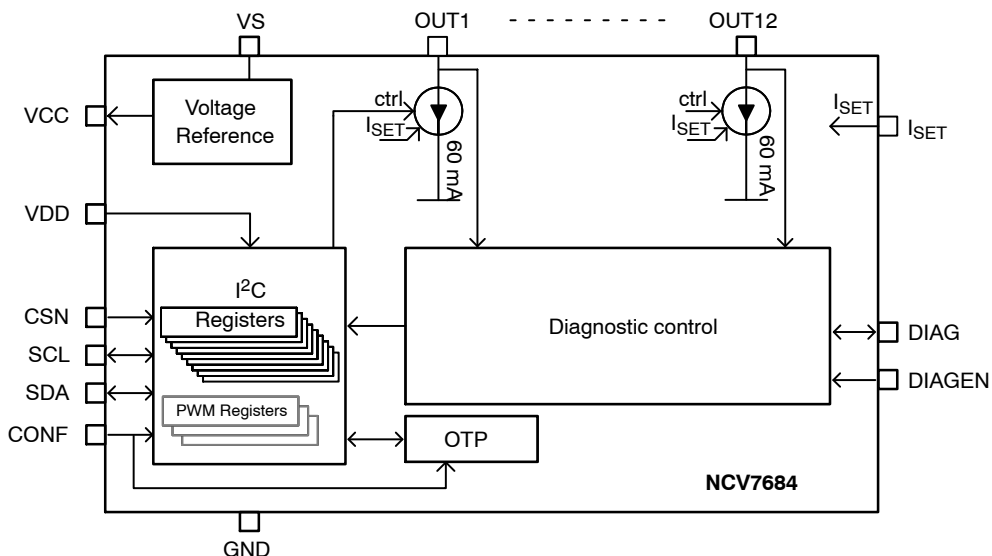

Figure 1. Block Diagram

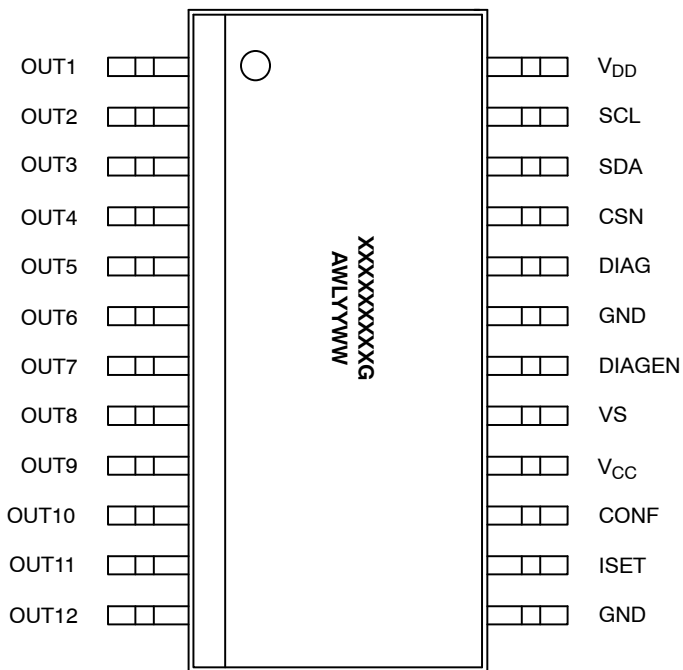

Figure 2. Pinout Diagram

NCV7684

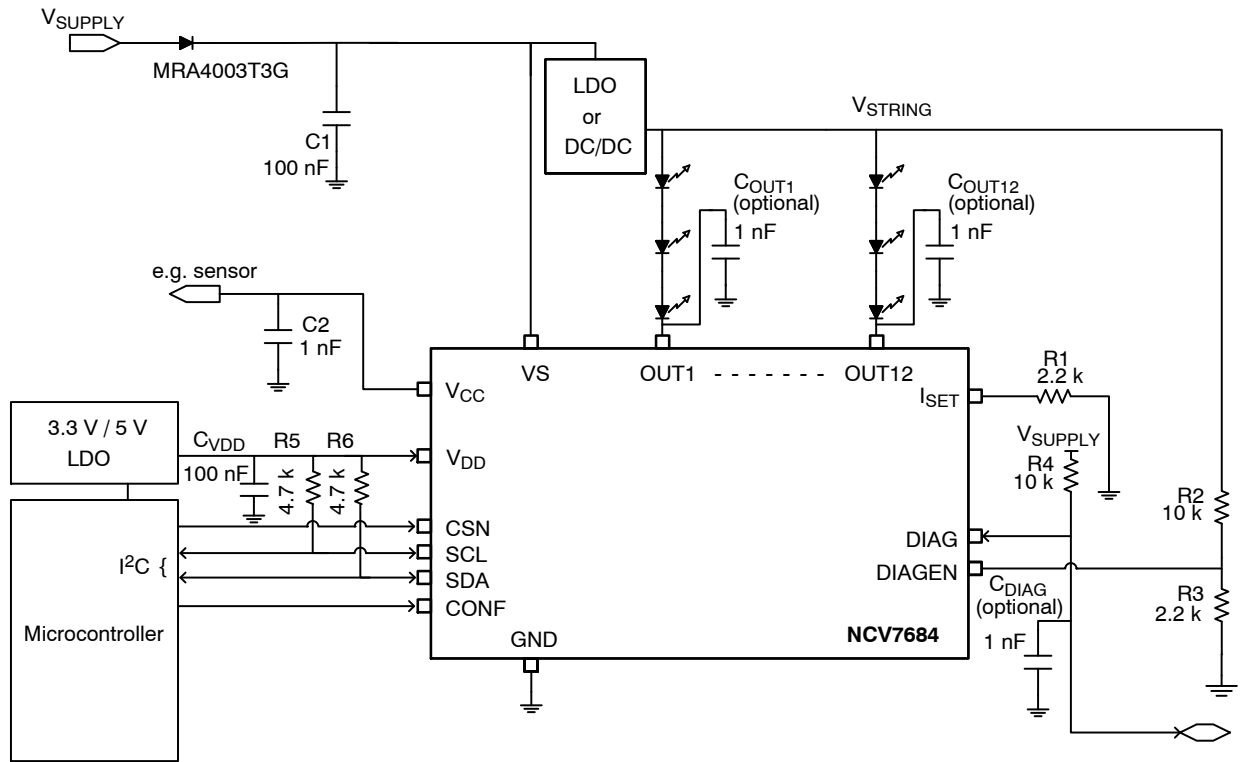

Figure 3. Application Diagram with Micro-controller (I²C Mode)

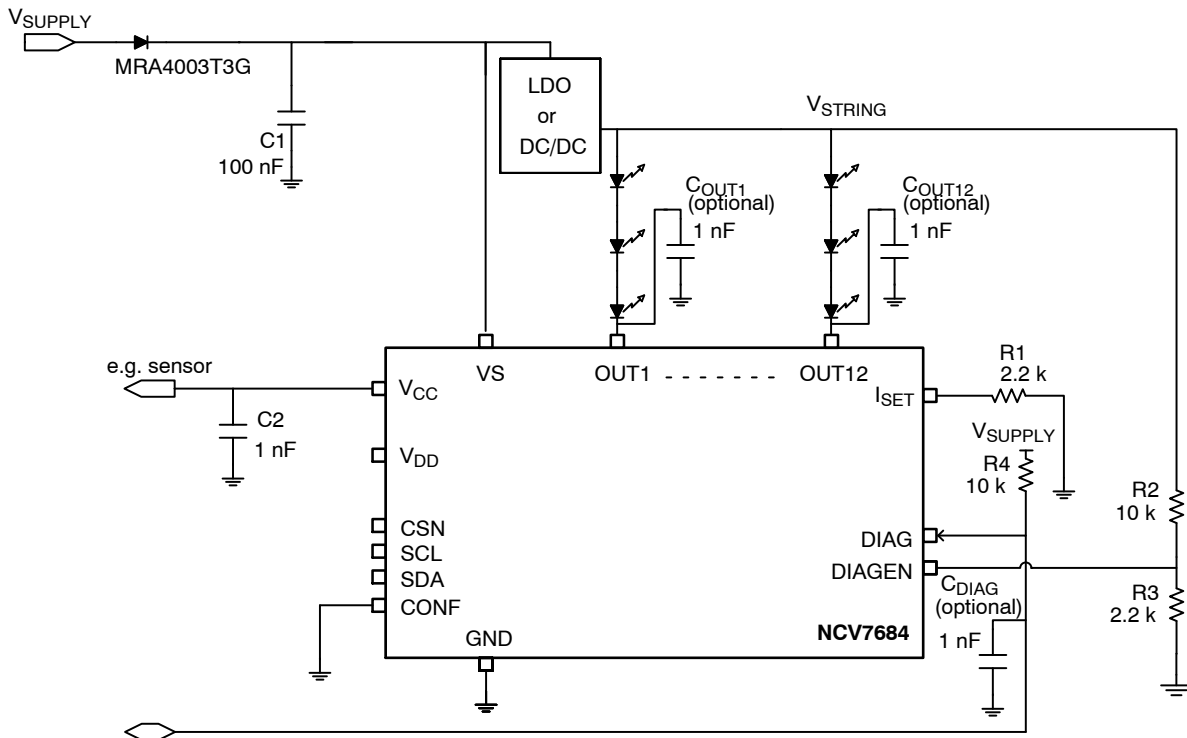

Figure 4. Application Diagram without Micro-controller (Stand Alone Mode)

Pin Function Description

Table 1. PIN FUNCTION DESCRIPTION

Pin #	Label	Description
1	OUT1	Channel 1 Current Output to LED
2	OUT2	Channel 2 Current Output to LED
3	OUT3	Channel 3 Current Output to LED
4	OUT4	Channel 4 Current Output to LED
5	OUT5	Channel 5 Current Output to LED
6	OUT6	Channel 6 Current Output to LED
7	OUT7	Channel 7 Current Output to LED
8	OUT8	Channel 8 Current Output to LED
9	OUT9	Channel 9 Current Output to LED
10	OUT10	Channel 10 Current Output to LED
11	OUT11	Channel 11 Current Output to LED
12	OUT12	Channel 12 Current Output to LED
13	GND	Ground
14	ISET	Current Setting
15	CONF	Stand Alone Mode Selection Bank
16	V _{CC}	3.3 V Voltage Reference Output (Needs External Decoupling Capacitor)
17	VS	Supply Voltage Input
18	DIAGEN	Diagnostic Voltage Sensing Node for V _{STRING} Via Resistor Divider
19	GND	Ground
20	DIAG	Open-drain diagnostic input/output. Reporting Open Circuit and thermal shutdown. Normal Operation = HIGH
21	CSN	End of Line Chip Select
22	SDA	I ² C Serial Data
23	SCL	I ² C Serial Clock
24	V _{DD}	Digital Supply Voltage Input
epad	epad	True Ground Do NOT Connect to PCB Traces other than GND

Maximum Ratings

Table 2. ABSOLUTE MAXIMUM RATINGS

Symbol	Parameter	Min	Max	Unit
V _{MAX_VS}	Power supply voltage: Continuous supply voltage Transient Voltage (t < 500 ms, "load dump")	-0.3	28	V
		-0.3	40	V
V _{MAX_INx}	Input pin voltage (DIAGEN, DIAG, CONF, CSN)	-0.3	40	V
V _{MAX_OUTx}	Continuous Output Pin voltage Transient Voltage (t < 500 ms, "load dump")	-0.3	28	V
		-0.3	40	V
V _{MAX_VCC}	Stabilized output voltage (V _{CC})	-0.3	3.6	V
V _{MAX_VDD}	Digital input supply voltage (V _{DD})	-0.3	5.5	V
V _{MAX_IO}	DC voltage at pins (V _{DD} , SCL, SDA)	-0.3	5.5	V
V _{MAX_ISET}	DC voltage at pin ISET	-0.3	3.6	V
I _{MAX_GND}	Maximum Ground Current	-	750	mA
T _{JMAX}	Junction Temperature, T _J	-40	150	°C

Stresses exceeding those listed in the Maximum Ratings table may damage the device. If any of these limits are exceeded, device functionality should not be assumed, damage may occur and reliability may be affected.

1. Integrated protection functions are designed to prevent IC destruction under fault conditions described in the datasheet. Fault conditions are considered as outside normal operating range. Protection functions are not designed for continuous repetitive operation.

ESD Protection and Packaging

Table 3. EDS PROTECTION (Note 1)

Parameter	Value	Unit
ESD Voltage, HBM (Human Body Model); (100 μ F, 1500 Ω) All Pins Output Pins OUTx to GND	± 2 ± 4	kV
ESD According to CDM (Charge Device Model) All Pins Corner Pins	± 500 ± 750	V
ESD According to MM (Machine Model) All Pins	± 150	V
Moisture Sensitivity (SSOP24-EP)	MSL3	
Package Thermal Resistance Junction to Ambient (SSOP24-EP)	37	$^{\circ}$ C/W

- This device series incorporates ESD protection and is tested by the following methods:
ESD HBM tested per AEC-Q100-002 (EIA/JESD22-A114)
ESD CDM tested per EIA/JES D22/C101, Field Induced Charge Model
MM according to AEC-Q100

Table 4. ELECTRICAL CHARACTERISTICS

(5 V < VS < 18 V, 3.15 V < V_{DD} < 5.5 V, R1 = 1.82 k Ω , -40 $^{\circ}$ C \leq T_J \leq 150 $^{\circ}$ C, unless otherwise specified)

Characteristic	Symbol	Conditions	Min	Typ	Max	Unit
GENERAL						
Supply Voltage	VS_EXT	Functional extended range (limited temperature)	5	-	28	V
	VS_OP	Parametric operation	5	-	18	V
Supply Under-Voltage	VSUV	VS rising	3.8	4.1	4.4	V
Supply Under-Voltage Hysteresis	VSUV _{HYS}	-	-	200	-	mV
Supply Current (Vs)	I _S (error mode)	All OUTx OFF except channel in open load, VS = 12 V V _{DD} = 0 V				
		I _{OUT_VCC} = 0 mA	-	1.2	1.5	mA
		I _{OUT_VCC} = 1 mA	-	2.2	2.5	mA
	I _S (active)	Active Mode, V _{CC} unloaded, VS = 16 V, R1 = 2 k Ω	-	7	10	mA
Digital Supply Current	I _{DD}	I ² C mode, V _{DD} = 5 V, VS = 16 V		1.5	2.0	mA
V _{DD} Under Voltage Detection	V _{DDUV_R}	V _{DD} rising			2.9	V
	V _{DDUV_F}	V _{DD} falling	2			V

Table 4. ELECTRICAL CHARACTERISTICS (continued)

(5 V < VS < 18 V, 3.15 V < VDD < 5.5 V, R1 = 1.82 kΩ, -40°C ≤ TJ ≤ 150°C, unless otherwise specified)

Characteristic	Symbol	Conditions	Min	Typ	Max	Unit
CURRENT SOURCE OUTPUTS						
Output Current	I _{OUTHOT}	OUTx = 1 V, TJ = 150°C	50	55	60	mA
	I _{OUTCOLD}	OUTx = 0.5 V, TJ = -40°C	50	55	60	mA
Current Matching from Channel to Channel	I _{MATCHCOLD}	TJ = -40°C (Note 1)	-7	0	7	%
	I _{MATCH}	TJ = 25°C (Note 1)	-6	0	6	%
	I _{MATCHHOT}	TJ = 150°C (Note 1)	-5	0	5	%
Current Slew Rate	ISR _x	10% to 90%	-	30	-	mA/μs
Open Circuit Detection Threshold	OLDT	I _{OUTx} > 20 mA	30	50	70	% of output current
Open Load Recovery in Auto-recovery Mode	OLR	-	5	10	15	mA

Product parametric performance is indicated in the Electrical Characteristics for the listed test conditions, unless otherwise noted. Product performance may not be indicated by the Electrical Characteristics if operated under different conditions.

1. Matching formulas:

$$\left[\frac{2I_{OUTx(min)}}{I_{OUTx(min)} + I_{OUTx(max)}} - 1 \right] \times 100 \text{ and } \left[\frac{2I_{OUTx(max)}}{I_{OUTx(min)} + I_{OUTx(max)}} - 1 \right] \times 100 \quad (\text{eq. 1})$$

Table 5. ELECTRICAL CHARACTERISTICS

(5 V < VS < 18 V, 3.15 V < VDD < 5.5 V, R1 = 1.82 kΩ, -40°C ≤ TJ ≤ 150°C, unless otherwise specified)

Symbol	Parameter	Test Conditions	Min	Typ	Max	Unit
VOLTAGE REFERENCE						
V _{VCC}	Output Voltage Tolerance	I _{VCC} ≤ 1 mA	3.20	3.30	3.45	V
I _{OUT_VCC}	Output Current	-	-	-	-1	mA
C _{LOAD_VCC}	Load Capacitor	ESR < 200 mΩ	0.9	1.0	2.5	nF
INPUTS: CSN, CONF						
V _{INL}	Input Low Level	-	0.7	1.0	-	V
V _{INH}	Input High Level	-	-	1.25	1.66	V
V _{IN_HYST}	Input Hysteresis	-	100	250	400	mV
R _{IN_PD}	Input Pull-down Resistor	0 V < V _{IN} < 0.8 V	120	200	280	kΩ
INPUTS: SCL, SDA						
V _{INL}	Input Low Level	-	-	-	0.3 × V _{DD}	V
V _{INH}	Input High Level	-	0.7 × V _{DD}	-	-	V
V _{IN_HYST}	Input Hysteresis	-	0.05 × V _{DD}	-	-	V
I _{OUT_SDA}	Output Current	V (SDA) = 0.4 V	3	-	-	mA
DIAGEN PIN						
V _{DIAGENTH}	VS Diagnostic Enable Threshold	-	1.9	2.0	2.1	V
R _{DIAGEN_PD}	Input Pull-down Resistor	0 V < V _{DIAG} < 0.9 V	120	200	280	kΩ
DIAG PIN						
V _{OUTL}	Output Low Level	Diagnostic Activated, I _{DIAG} = 1 mA	-	0.2	0.4	V
DiagRes	Diagnostic Reset Voltage	-	1.65	1.80	1.95	V
tp _{DIAG}	Filter Time to Set the DIAG Fail Pin in Failure Mode	I _{DIAG} = 1 mA	-	10	20	μs
DIAG _{leak}	DIAG Output Leakage	V _{DIAG} = 5 V	-	-	10	μA

NCV7684

Table 5. ELECTRICAL CHARACTERISTICS (continued)

(5 V < VS < 18 V, 3.15 V < VDD < 5.5 V, R1 = 1.82 kΩ, -40°C ≤ TJ ≤ 150°C, unless otherwise specified)

Symbol	Parameter	Test Conditions	Min	Typ	Max	Unit
ISET INPUT PIN						
VISET	Global Current Setting	-	0.94	1.00	1.06	V
K	IOOUT ISET Factor	-	-	100	-	-
tsetupISET	Setup-up Time to 90% of the ISET Regulated Value	VS > 5 V	-	-	50	μs
INTERNAL PWM CONTROL UNIT (OUT1- OUT12)						
PWM1	PWM1 Frequency, I ² C Mode	Configuration Via I ² C	220	250	280	Hz
PWM2	PWM2 Frequency, I ² C Mode	Configuration Via I ² C	110	125	140	Hz
PWM3	PWM3 Frequency, I ² C Mode	Configuration Via I ² C	440	500	560	Hz

Table 6. THERMAL WARNING AND THERMAL SHUTDOWN PROTECTION

Characteristic	Symbol	Min	Typ	Max	Unit
T _{JWAR_ON}	Thermal Warning Threshold (Junction Temperature)	-	TSD - 30	-	°C
TSD	Thermal Shutdown Threshold (Junction Temperature) T _J Increasing	160	-	180	°C
T _{JSD_HYS}	Thermal Shutdown Hysteresis	10	-	15	°C

General

The NCV7684 is a twelve channel LED driver. Each output can drive currents up to 60 mA/channel and are programmable via an external resistor. The target applications for the device are in automotive rear lighting systems and dashboard applications. The device can be used with micro-controller applications using the I²C bus or in stand-alone applications. In both cases it is mandatory to supply the LED channels by an external ballast transistor, or by an LDO or a DC/DC. In order to have very low electromagnetic emission, this device has an embedded spread spectrum oscillator.

Example:

R1 = 2 kΩ
 using eq. 2 → I_{SET} = 500 μA
 and using eq. 3 → I_{OUTx} = 50 mA

To avoid potential disturbances when all drivers are activated at the same time, a typical activation delay of 400 ns between groups of 2 consecutive outputs is implemented (see Figure 5).

Output Current Programming (I_{SET}/OUTx)

The maximum current can be defined with the Iset input pin. The equations below can be used to calculate this maximum output current:

$$I_{set} = 1 \text{ V}/R1 \quad (\text{eq. 2})$$

$$I_{OUTx} = K \times I_{set} \quad (\text{eq. 3})$$

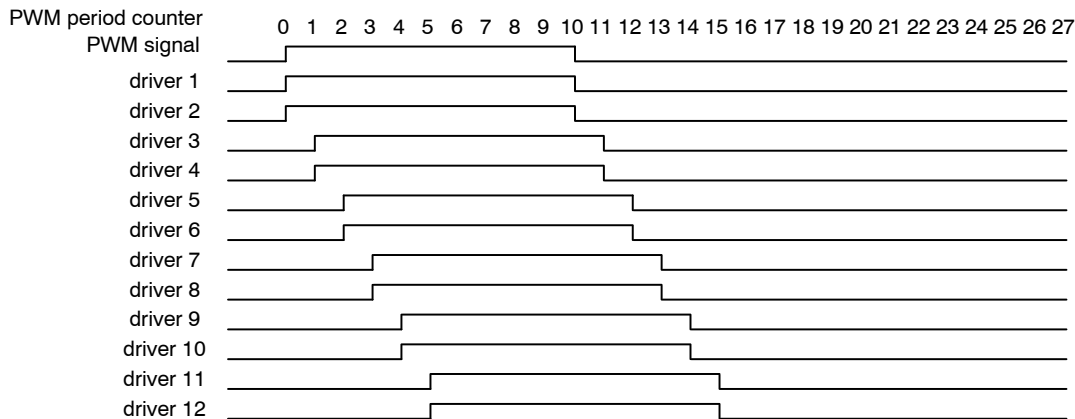

Figure 5.

Power Supply and Voltage Reference (VS, V_{CC}, V_{DD})

VS is the analog power supply input of the device. VS supply is monitored with respect to the crossing of VSUV level (typ. 4.1 V). When VS rises above VSUV, the device starts the power-up state. When VS is above the VS_OP minimum level (typ. 5 V), the device can work properly.

V_{CC} is a voltage reference providing 3.3 V derived from the VS main supply. It is able to deliver up to 1 mA and is primarily intended to supply 3.3 V loads.

V_{DD} is the digital power supply input of the device.

Ground Connections (GND: Pin 13 and Pin 19)

The device ground connection is split to two pins called GND. Both pins have to be connected on the application PCB.

Chip Select (CSN)

The device can be programmable using the I²C bus in End Of Line cases. When the CSN pin has a voltage above 1.66 V, the device will be set in zapping control mode via the I²C

bus. When CSN will be connected to ground or below 0.7 V, the device will be in a mode where zapping is not possible. Zapping is only possible with VS above 13 V.

Configuration (CONF)

When the CONF input voltage will be below 0.7 V the configuration 1 will be selected (One Time Programmable OTP 1 register called SAM_CONF_1) and when the CONF input voltage will be above 1.66 V the configuration 2 will be selected (OTP 2 register called SAM_CONF_2). There is ability to change the configuration in error mode (either with CONF in SAM or through I²C in I2C mode).

I²C Bus (SCL, SDA)

The I²C bus consists of two wires, Serial Data (SDA) and Serial Clock (SCL), carrying information between the devices connected on the bus. Each device connected to the bus is recognized by a unique address and operates as either a transmitter or receiver, depending on the function of the device. The NCV7684 can both receive and transmit data

NCV7684

with CRC8 error detection algorithm. The NCV7684 is a slave device.

SDA is a bi-directional line connected to a positive supply voltage via an external pull-up resistor. When the bus is free both lines are HIGH. The output stages of the devices connected to the bus must have an open drain to perform the wired-AND function. Data on the I²C bus can be transferred up to 400 kb/s.

Diagnostic Enabling (DIAGEN)

The device is capable to detect for each independent channel an open load condition. Versus the number of LEDs and the V_{STRING} voltage supply, a wrong open load condition can be detected if the fault detection is activated when there is not enough voltage across the LEDs. This threshold can be programmable thanks to an external divider connected to the DIAGEN pin. When the divided voltage is below a typical value of 2 V, the LED diagnostic is disabled. When the divided voltage is above the typical value of 2 V, the LED diagnostic is enabled.

Diagnostic Feedback (DIAG)

The DIAG is an open drain output pin who can alert a microcontroller as soon as one of the outputs is in error mode (DIAG Low = open load or thermal shut-down or Iset shorted). Forcing the DIAG pin below 1.8 V will force a fault condition if the DIAGEN input pin is above a typical value of 2 V. If the DIAGEN input pin is below the typical value of 2 V then forcing the DIAG input pin will not have any effect.

Parallel Outputs (OUTx)

The maximum rating per output is 60 mA. In order to increase system level LED string current, parallel combinations of any number of outputs is allowed. Combining all 12 outputs will allow for a maximum system level string current design of 720 mA.

DIGITAL PART AND I²C REGISTERS

The I²C bus consists of two wires, serial data (SDA) and serial clock (SCL), carrying information between the devices connected on the bus. Each device connected to the bus is recognized by a unique address. The NCV7684 can both receive and transmit data with CRC8 error detection

algorithm. The NCV7684 is a slave device only. Generation of the signals on the I²C bus is always the responsibility of the master device.

They are multiple kinds of message structure possible versus ID code received.

Table 7. IDENTIFIER ADDRESSING (ID) MESSAGE

Name	ID	Access type	Name of Register Addressed
ID_I2C_CONF	00	W	I2C_CONF
ID_PWM	01	W	PWM_GAIN, PWM_GAIN_EN
ID_WRITEALL	02	W	I2C_CONF, PWM_GAIN, PWM_GAIN_EN
ID_PWM_CONF	03	W	PWM_CONF
ID_STATUS	08	R	I2C_STATUS
ID_FAULT	09	R	FAULT_STATUS
ID_READALL	0A	R	I2C_CH_STATUS, I2C_STATUS, FAULT_STATUS
ID_SET_OTP	20	W	SAM_CONF_1, SAM_CONF_2, ADD_SAM_SET
ID_LOCK_OTP	21	W	SAM_CONF_1, SAM_CONF_2, ADD_SAM_SET
ID_READ_OTP	28	R	ID_VERS_1, ID_VERS_2, SAM_CONF_1, SAM_CONF_2, ADD_SAM_SET

There are 3 kinds of registers, Hard Coding, OTP and volatile registers.

Hard Coding Registers:

- ID_VERS_1
- ID_VERS_2

OTP Registers:

- ADD_SAM_SET
- SAM_CONF_1
- SAM_CONF_2

Volatile Registers:

- I2C_CONF
- I2C_STATUS
- I2C_CH_STATUS
- FAULT_STATUS
- PWM_GAIN
- PWM_GAIN_EN
- PWM_CONF

Format of the I2C frames

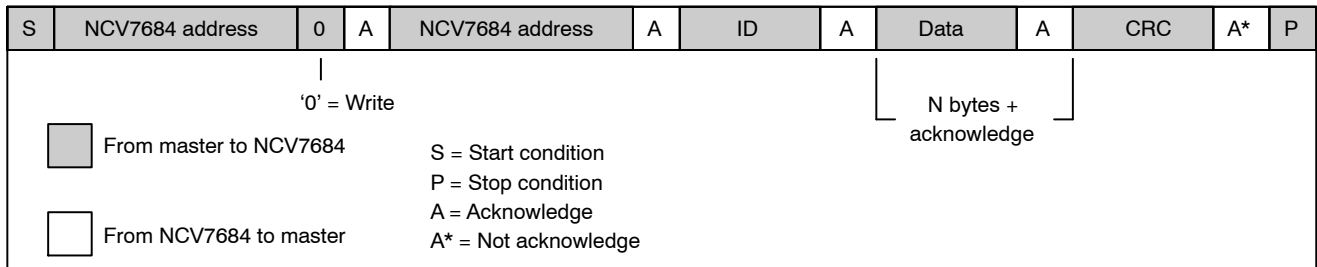

Figure 6. Format of I²C Write Access Frames

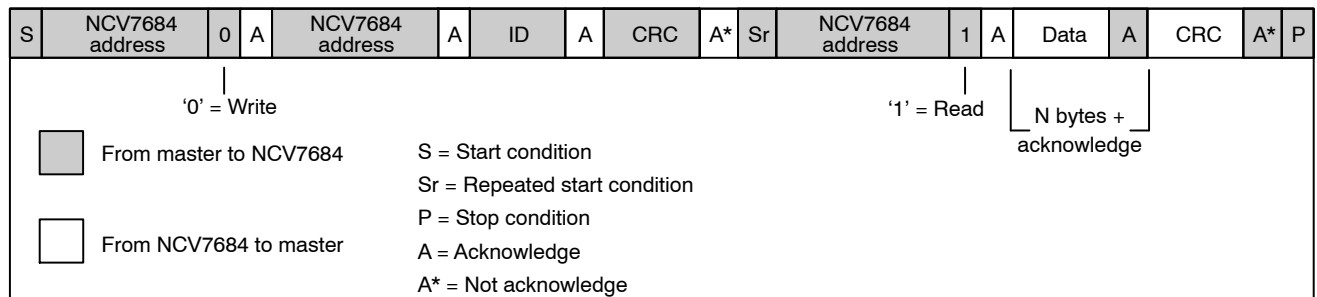

Figure 7. Format of I²C Read Access Frames

Remark: CRC byte is not transmitted when CRC protection is turned off (ERREN = 0)

S	NCV7684 Address	0	NCV7684 Address	ID_I2C_CONF	I2C_CONF[15:8]	I2C_CONF[7:0]	CRC	P							
S	NCV7684 Address	0	NCV7684 Address	ID_PWM	PWM_GAIN	PWM_GAIN_EN[15:8]	PWM_GAIN_EN[7:0]	CRC							
S	NCV7684 Address	0	NCV7684 Address	ID_WRITEALL	I2C_CONF[15:8]	I2C_CONF[7:0]	PWM_GAIN	PWM_GAIN_EN[15:8]	PWM_GAIN_EN[7:0]	CRC	P				
S	NCV7684 Address	0	NCV7684 Address	ID_PWM_CONF	PWM_CONF	CRC	P								
S	NCV7684 Address	0	NCV7684 Address	ID_STATUS	CRC	Sr	NCV7684 Address	1	I2C_STATUS	CRC	P				
S	NCV7684 Address	0	NCV7684 Address	ID_FAULT	CRC	Sr	NCV7684 Address	1	FAULT_STATUS[15:8]	FAULT_STATUS[7:0]	CRC	P			
S	NCV7684 Address	0	NCV7684 Address	ID_READALL	CRC	Sr	NCV7684 Address	1	I2C_CH_STATUS[15:8]	I2C_CH_STATUS[7:0]	I2C_STATUS	FAULT_STATUS[15:8]	FAULT_STATUS[7:0]	CRC	P

Figure 8. Format of I²C Frames

- From master to NCV7684
 - From NCV7684 to master
- Acknowledges are omitted
 S = Start condition
 Sr = Repeated start condition
 P = Stop condition

S	NCV7684 Address	0	NCV7684 Address	ID_SET_OTP	SAM_CONF_1[15:8]	SAM_CONF_1[7:0]	SAM_CONF_2[15:8]	SAM_CONF_2[7:0]	ADD_SAM_SET	CRC	P						
S	NCV7684 Address	0	NCV7684 Address	ID_LOCK_OTP	SAM_CONF_1[15:8]	SAM_CONF_1[7:0]	SAM_CONF_2[15:8]	SAM_CONF_2[7:0]	ADD_SAM_SET	CRC	P						
S	NCV7684 Address	0	NCV7684 Address	ID_READ_OTP	CRC	Sr	NCV7684 Address	1	ID_VERS_1	ID_VERS_2	SAM_CONF_1[15:8]	SAM_CONF_1[7:0]	SAM_CONF_2[15:8]	SAM_CONF_2[7:0]	ADD_SAM_SET	CRC	P

Figure 9. Format of I²C OTP Frames

- From master to NCV7684
 - From NCV7684 to master
- Acknowledges are omitted
 S = Start condition
 Sr = Repeated start condition
 P = Stop condition

Note: Not to scale.

NCV7684

There is a safety mechanism implemented by repeating the address. Since the I²C address is 7 bits long, first bit of the second address byte starts with a “0” in the repeated byte (see tables below).

Table 8.

1 st Byte							
7	6	5	4	3	2	1	0
I ² C Device Address							R/W Bit
2 nd Byte							
7	6	5	4	3	2	1	0
I ² C Device Address							0

HARD CODING REGISTERS

Table 9. HARD CODING REGISTERS

Bit	D7	D6	D5	D4	D3	D2	D1	D0
-----	----	----	----	----	----	----	----	----

ID_VERS_1

Bit name	ID1[7:0]							
Access type	R	R	R	R	R	R	R	R
Reset value	0	1	0	0	0	0	1	1

ID_VERS_2

Bit name	ID2[7:0]							
Access type	R	R	R	R	R	R	R	R
Reset value	0	0	0	0	0	0	1	0

- ID1[7:0] = 43h (ON Semi Device Identifier)
ID2[7:0] = 02h (The Actual Version)

OTP REGISTERS

Table 10. ADD_SAM_SET

Bit	D7	D6	D5	D4	D3	D2	D1	D0
Bit name	AUTOR	DETONLY	ERREN	ADD[4:0]				
Access type	R/W	R/W	R/W	R/W	R/W	R/W	R/W	R/W
Reset value	0	1	0	0	0	0	0	0

ADD[4:0] are the programmable BUS address registers (in I2C mode ADD[6:5] = 11).

AUTOR: When AUTOR = 1 (and DIAGEN is high), open load diagnosis is performed. When a fault is detected, the DIAG pin is set and LED driver imposes a low current on the faulty branch alone, switching off the others. When fault is recovered, LED driver returns to normal operation after resetting the DIAG pin. If the DIAG pin is triggered externally, LED driver outputs are switched off and the low power mode is entered.

DETONLY: When DETONLY = 1, open load diagnostic is performed. When a fault is detected, the DIAG pin is set without taking any action on the current regulation. When fault is recovered, DIAG is reset. If the DIAG pin is triggered externally, no action is taken.

When AUTOR = DETONLY = 0, no diagnostic performed
 When AUTOR = DETONLY = 1, no change (same as previously setting).

ERREN: When ERREN = 1, CRC error detection algorithm is activated for I²C communication.

Table 11. SAM_CONF

Bit	D15	D14	D13	D12	D11	D10	D9	D8	D7	D6	D5	D4	D3	D2	D1	D0
-----	-----	-----	-----	-----	-----	-----	----	----	----	----	----	----	----	----	----	----

SAM_CONF_1

Bit name	-	-	-	-	SAM1conf[11:0]											
Access type	R	R	R	R	R/W	R/W	R/W	R/W	R/W	R/W	R/W	R/W	R/W	R/W	R/W	R/W
Reset value	0	0	0	0	1	1	1	1	1	1	1	1	1	1	1	1

SAM_CONF_2

Bit name	-	-	-	-	SAM2conf[11:0]											
Access type	R	R	R	R	R/W	R/W	R/W	R/W	R/W	R/W	R/W	R/W	R/W	R/W	R/W	R/W
Reset value	0	0	0	0	1	1	1	1	1	1	1	1	1	1	1	1

- SAM1conf[x] = 0 means channel is OFF and SAM1conf[x] = 1 means channel is ON
 SAM2conf[x] = 0 means channel is OFF and SAM2conf[x] = 1 means channel is ON

VOLATILE REGISTERS

Table 12. I2C_CONF

Bit	D15	D14	D13	D12	D11	D10	D9	D8	D7	D6	D5	D4	D3	D2	D1	D0
Bit name	I2CFLAG	I2CautoR	I2CdOnly	PWMEN	I2Cconf[11:0]											
Access type	W	W	W	W	W	W	W	W	W	W	W	W	W	W	W	W
Reset value	0	0	0	0	0	0	0	0	0	0	0	0	0	0	0	0

I2CFLAG: the I2CFLAG should be reset whenever standalone mode is entered. When I2CFLAG = 1 and when V_{DD} is high, the I2C mode is activated, in all other conditions the device is in Stand Alone Mode.

I2CautoR: When I2CautoR = 1 (and DIAGEN is high), open load diagnosis is performed. When a fault is detected, the DIAG pin is set and LED driver imposes a low current on the faulty branch alone, switching off the others. When fault is recovered, LED driver returns to normal operation after resetting the DIAG pin. If the DIAG pin is triggered externally, LED driver outputs are switched off and the low power mode is entered.

I2CdOnly: When I2CdOnly = 1, open load diagnostic is performed. When a fault is detected, the DIAG pin is set

without taking any action on the current regulation. When fault is recovered, DIAG is reset. If the DIAG pin is triggered externally, no action is taken.

When I2CautoR = I2CdOnly = 0, no diagnostic performed.

When I2CautoR = I2CdOnly = 1, no change (same as previously setting).

PWMEN: When PWMEN = 1, PWM is activated, when PWMEN = 0 the content of the complete register PWM_GAIN_EN is not reset and PWM is disabled.

I2Cconf[x] = 0 means channel is OFF and I2Cconf[x] = 1 means channel is ON.

Table 13. I2C STATUS

Bit	D7	D6	D5	D4	D3	D2	D1	D0
Bit name	SC_Iset	I2Cerr	UV	diagRange	TW	TSD	DIAGERR	OL
Access type	R	R	R	R	R	R	R	R
Reset value	0	0	0	0	0	0	0	0

SC_Iset: SC_Iset = 1 means there is short-circuit on the external resistor on Iset pin and drivers are switched OFF and DIAG pin is set. SC_Iset = 0 no short-circuit.

I2Cerr: I2Cerr = 1 means an error has been detected during the I2C communication, I2Cerr = 0 means no error during I2C communication has been detected.

UV: the device is in under voltage condition (VS is below VSUV threshold, all channels OFF).

diagRange: when diagRange = 1 the divided voltage is above the typical value of 2 V (LED diagnostic is enabled), diagRange = 0 means the divided voltage is below the typical value of 2 V (LED diagnostic is disabled).

TW: when TW=1 the device is in the thermal warning range (typ. 140°C), this flag is just a warning no action is foreseen on the output drivers. TW = 0 means the device is below the thermal warning range.

TSD: when TSD = 1 the device is in the Thermal shutdown range, TSD = 0 means the device is below the thermal shutdown range.

DIAGERR: DIAGERR = 1 means an error is detected by DIAG pin forced externally.

OL: OL = 1 means at least one channel is in Open Load condition, OL = 0 no Open Load.

Table 14.

SC_ISET	Set when a short-circuit on the external resistor on Iset pin, latched if permanent after 10 μs. Reset in case of short-circuit disappear permanently for at least 10 μs
I2CERR	Set if an error has been detected during the I2C communication. Reset on register reading
UV	Set when device is in under voltage condition (VS is low, all channels OFF)
diagRange	Set when divided voltage is above the V _{DIAGEN} TH threshold. Reset when the divided voltage is below the V _{DIAGEN} TH threshold
TW	Set when junction temperature is above the T _{JWAR_ON} threshold. Reset on register reading and if temperature is below the (T _{JWAR_ON} - T _{JSD_HYS}) threshold
TSD	Set when junction temperature is above the TSD threshold. Reset on register reading and if temperature is below the TSD - T _{JSD_HYS} threshold

Table 14. (continued)

DIAGERR	Set by DIAG pin forced low externally, latched if permanent after 10 μ s. Reset in case DIAG pin is not forced permanently for at least 10 μ s
OL	Set in Open Load condition and DIAGEN is high, latched if permanent after 10 μ s. Reset if Open Load disappear permanently for at least 10 μ s. Fault information is maintained on falling DIAGEN threshold exceeded

Table 15. I2C_CH_STATUS

Bit	D15	D14	D13	D12	D11	D10	D9	D8	D7	D6	D5	D4	D3	D2	D1	D0
Bit name	I2CFLAG	I2CautoR	I2CdOnly	PWMEN	I2C_CH_STATUS[11:0]											
Access type	R	R	R	R	R	R	R	R	R	R	R	R	R	R	R	R
Reset value	0	0	0	0	0	0	0	0	0	0	0	0	0	0	0	0

I2CFLAG: same as I2C_CONF register.

I2CautoR: same as I2C_CONF register.

I2CdOnly: same as I2C_CONF register.

PWMEN: same as I2C_CONF register.

I2C_CH_STATUS[11:0]: same as I2C_CONF[11:0] bits in I2C mode or same as SAM_CONF_1[11:0], SAM_CONF_2[11:0] bits in Standalone mode.

Remark: When NCV7684 is configured in I2C mode and output channel OUTx is configured to operate in PWM mode, I2C_CH_STATUS[x] shall contain value ‘1’.

Table 16. FAULT_STATUS

Bit	D15	D14	D13	D12	D11	D10	D9	D8	D7	D6	D5	D4	D3	D2	D1	D0
Bit name	-	-	-	-	FAULT[11:0]											
Access type	R	R	R	R	R	R	R	R	R	R	R	R	R	R	R	R
Reset value	0	0	0	0	0	0	0	0	0	0	0	0	0	0	0	0

FAULT[11:0]: when FAULT[x] = 1 the OUTx channel is in fault mode (Open Load latched when the duration is longer than 10 μ s), when FAULT[x] = 0 the OUTx channel

is working properly. The register is reset on each read operation.

Table 17. PWM_GAIN

Bit	D7	D6	D5	D4	D3	D2	D1	D0
Bit Name	PWMF1	PWMGAIN[6:0]						
Access type	W	W	W	W	W	W	W	W
Reset Value	0	0	0	0	0	0	0	0

PWMGAIN[6:0]: logarithmic (or linear) dimming via embedded PWM generator (128 steps). Following formula applies when logarithmic dimming is selected:
 $Duty_Cycle_Percent = 100 \times \alpha^{(N-i)}$ where $\alpha = 0.9471$,
 $N = 127$ and $i = PWMGAIN[6:0]$ rounded with an accuracy of 400 ns.

PWMF1: when PWMF1 = 1, PWM dimming is done at a typical frequency of 250 Hz, when PWMF1 = 0 means PWM dimming is done at a typical frequency of 125 Hz (when PWMF2 = 0).

Table 18. PWM_GAIN_EN

Bit	D15	D14	D13	D12	D11	D10	D9	D8	D7	D6	D5	D4	D3	D2	D1	D0
Bit name	-	-	-	-	PWMGAINen[11:0]											
Access type	-	-	-	-	W	W	W	W	W	W	W	W	W	W	W	W
Reset value	0	0	0	0	0	0	0	0	0	0	0	0	0	0	0	0

PWMGAINen[11 :0] : when $PWMGAINen[x] = 1$, PWM dimming is enabled for OUTx channel, when $PWMGAINen[x] = 0$ means PWM dimming is disabled for OUTx channel.

Table 19. PWM_CONF

Bit	D7	D6	D5	D4	D3	D2	D1	D0
Bit name	-	-	-	-	-	-	PWMLIN	PWMF2
Access type	W	W	W	W	W	W	W	W
Reset value	0	0	0	0	0	0	0	0

PWMLIN bit shall select between logarithmic ($PWMLIN = 0$) and linear ($PWMLIN = 1$) translation of *PWMGAIN* bits to duty cycle of internal PWM signal.

PWMF2: when $PWMF2 = 1$, PWM dimming is done at a typical frequency of 500 Hz, when $PWMF2 = 0$, *PWMF1* setting applies.

MECHANICAL CASE OUTLINE PACKAGE DIMENSIONS

ON Semiconductor®



SSOP24 NB EP
CASE 940AP
ISSUE O

DATE 05 MAR 2015

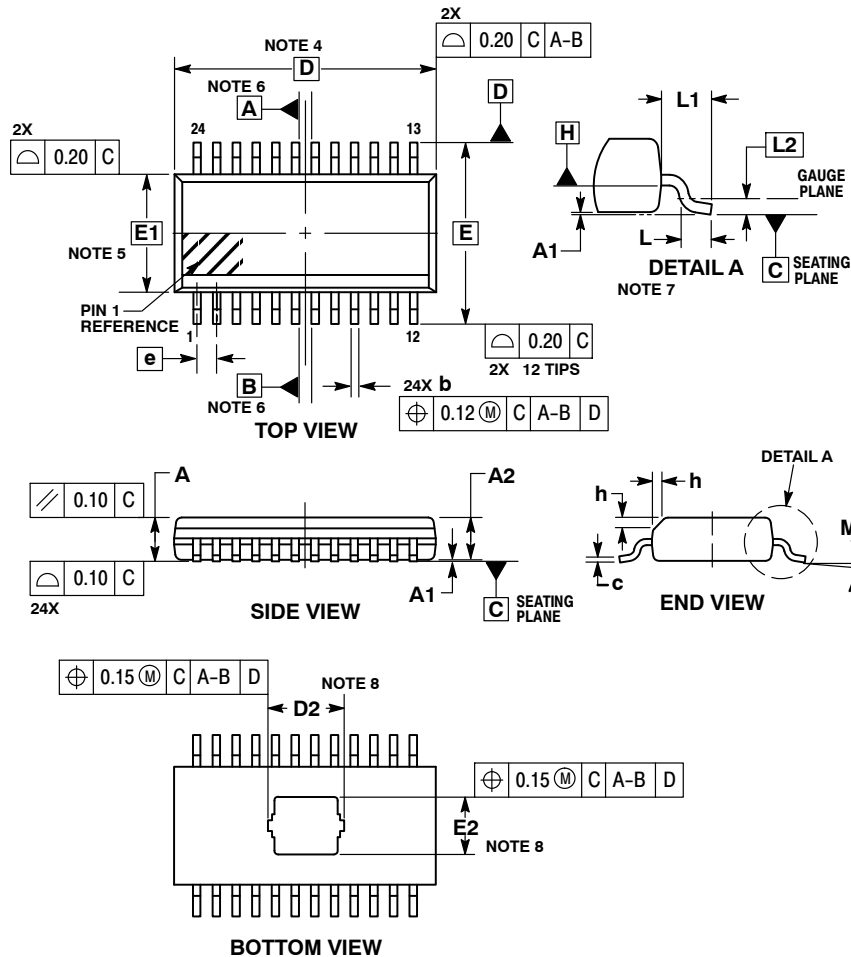

NOTES:

1. DIMENSIONING AND TOLERANCING PER ASME Y14.5M, 1994.
2. CONTROLLING DIMENSION: MILLIMETERS.
3. DIMENSION **b** DOES NOT INCLUDE DAMBAR PROTRUSION. DAMBAR PROTRUSION SHALL BE 0.10 MAX. AT MMC. DAMBAR CANNOT BE LOCATED ON THE LOWER RADIUS OF THE FOOT. DIMENSION **b** APPLIES TO THE FLAT SECTION OF THE LEAD BETWEEN 0.10 TO 0.25 FROM THE LEAD TIP.
4. DIMENSION **D** DOES NOT INCLUDE MOLD FLASH, PROTRUSIONS OR GATE BURRS. MOLD FLASH, PROTRUSIONS OR GATE BURRS SHALL NOT EXCEED 0.15 PER SIDE. DIMENSION **D** IS DETERMINED AT DATUM PLANE **H**.
5. DIMENSION **E1** DOES NOT INCLUDE INTERLEAD FLASH OR PROTRUSION. INTERLEAD FLASH OR PROTRUSION SHALL NOT EXCEED 0.25 PER SIDE. DIMENSION **E1** IS DETERMINED AT DATUM PLANE **H**.
6. DATUMS **A** AND **B** ARE DETERMINED AT DATUM PLANE **H**.
7. **A1** IS DEFINED AS THE VERTICAL DISTANCE FROM THE SEATING PLANE TO THE LOWEST POINT ON THE PACKAGE BODY.
8. CONTOURS OF THE THERMAL PAD ARE UNCONTROLLED WITHIN THE REGION DEFINED BY DIMENSIONS **D2** AND **E2**.

MILLIMETERS		
DIM	MIN	MAX
A	---	1.75
A1	0.00	0.10
A2	1.10	1.65
b	0.19	0.30
c	0.09	0.20
D	8.64 BSC	
D2	2.37	2.67
E	6.00 BSC	
E1	3.90 BSC	
E2	1.79	1.99
e	0.65 BSC	
h	0.25	0.50
L	0.40	0.85
L1	1.00 REF	
L2	0.25 BSC	
M	0°	8°

GENERIC MARKING DIAGRAM*



- XXXX = Specific Device Code
- A = Assembly Location
- WL = Wafer Lot
- YY = Year
- WW = Work Week
- G = Pb-Free Package

(Note: Microdot may be in either location)

*This information is generic. Please refer to device data sheet for actual part marking. Pb-Free indicator, "G" or microdot "•", may or may not be present. Some products may not follow the Generic Marking.

RECOMMENDED SOLDERING FOOTPRINT

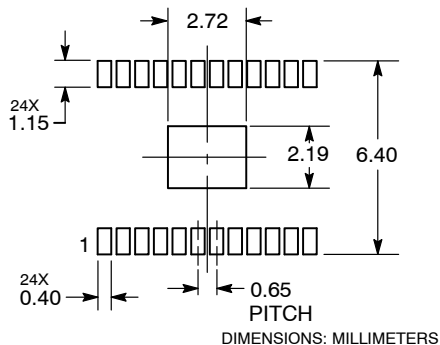

DOCUMENT NUMBER:	98AON96176F	Electronic versions are uncontrolled except when accessed directly from the Document Repository. Printed versions are uncontrolled except when stamped "CONTROLLED COPY" in red.
DESCRIPTION:	SSOP24 NB EP	PAGE 1 OF 1

ON Semiconductor and ON are trademarks of Semiconductor Components Industries, LLC dba ON Semiconductor or its subsidiaries in the United States and/or other countries. ON Semiconductor reserves the right to make changes without further notice to any products herein. ON Semiconductor makes no warranty, representation or guarantee regarding the suitability of its products for any particular purpose, nor does ON Semiconductor assume any liability arising out of the application or use of any product or circuit, and specifically disclaims any and all liability, including without limitation special, consequential or incidental damages. ON Semiconductor does not convey any license under its patent rights nor the rights of others.

onsemi, **Onsemi**, and other names, marks, and brands are registered and/or common law trademarks of Semiconductor Components Industries, LLC dba "**onsemi**" or its affiliates and/or subsidiaries in the United States and/or other countries. **onsemi** owns the rights to a number of patents, trademarks, copyrights, trade secrets, and other intellectual property. A listing of **onsemi**'s product/patent coverage may be accessed at www.onsemi.com/site/pdf/Patent-Marking.pdf. **onsemi** reserves the right to make changes at any time to any products or information herein, without notice. The information herein is provided "as-is" and **onsemi** makes no warranty, representation or guarantee regarding the accuracy of the information, product features, availability, functionality, or suitability of its products for any particular purpose, nor does **onsemi** assume any liability arising out of the application or use of any product or circuit, and specifically disclaims any and all liability, including without limitation special, consequential or incidental damages. Buyer is responsible for its products and applications using **onsemi** products, including compliance with all laws, regulations and safety requirements or standards, regardless of any support or applications information provided by **onsemi**. "Typical" parameters which may be provided in **onsemi** data sheets and/or specifications can and do vary in different applications and actual performance may vary over time. All operating parameters, including "Typicals" must be validated for each customer application by customer's technical experts. **onsemi** does not convey any license under any of its intellectual property rights nor the rights of others. **onsemi** products are not designed, intended, or authorized for use as a critical component in life support systems or any FDA Class 3 medical devices or medical devices with a same or similar classification in a foreign jurisdiction or any devices intended for implantation in the human body. Should Buyer purchase or use **onsemi** products for any such unintended or unauthorized application, Buyer shall indemnify and hold **onsemi** and its officers, employees, subsidiaries, affiliates, and distributors harmless against all claims, costs, damages, and expenses, and reasonable attorney fees arising out of, directly or indirectly, any claim of personal injury or death associated with such unintended or unauthorized use, even if such claim alleges that **onsemi** was negligent regarding the design or manufacture of the part. **onsemi** is an Equal Opportunity/Affirmative Action Employer. This literature is subject to all applicable copyright laws and is not for resale in any manner.

PUBLICATION ORDERING INFORMATION

LITERATURE FULFILLMENT:

Email Requests to: orderlit@onsemi.com

onsemi Website: www.onsemi.com

TECHNICAL SUPPORT

North American Technical Support:
Voice Mail: 1 800-282-9855 Toll Free USA/Canada
Phone: 011 421 33 790 2910

Europe, Middle East and Africa Technical Support:

Phone: 00421 33 790 2910

For additional information, please contact your local Sales Representative

X-ON Electronics

Largest Supplier of Electrical and Electronic Components

Click to view similar products for [LED Lighting Drivers](#) category:

Click to view products by [ON Semiconductor](#) manufacturer:

Other Similar products are found below :

[LV5235V-MPB-H](#) [MB39C602PNF-G-JNEFE1](#) [MIC2871YMK-T5](#) [AL1676-10BS7-13](#) [AL1676-20AS7-13](#) [AP5726WUG-7](#) [ICL8201](#)
[IS31BL3228B-UTLS2-TR](#) [IS31BL3506B-TTLS2-TR](#) [AL3157F-7](#) [AP5725FDCG-7](#) [AP5726FDCG-7](#) [LV52204MTTBG](#) [AP5725WUG-7](#)
[STP4CMPQTR](#) [NCL30086BDR2G](#) [CAT4004BHU2-GT3](#) [LV52207AXA-VH](#) [AP1694AS-13](#) [TLE4242EJ](#) [AS3688](#) [IS31LT3172-GRLS4-TR](#)
[TLD2311EL](#) [KTD2694EDQ-TR](#) [KTZ8864EJAA-TR](#) [IS32LT3174-GRLA3-TR](#) [MP2488DN-LF-Z](#) [NLM0010XTSA1](#) [AL1676-20BS7-13](#)
[ZXLD1370QESTTC](#) [MPQ7220GF-AEC1-P](#) [MPQ7220GR-AEC1-P](#) [MPQ4425BGJ-AEC1-P](#) [MPQ7220GF-AEC1-Z](#) [MPQ7220GR-AEC1-Z](#)
[MPQ4425BGJ-AEC1-Z](#) [NCL30486A2DR2G](#) [IS31FL3737B-QFLS4-TR](#) [IS31FL3239-QFLS4-TR](#) [KTD2058EUAC-TR](#) [KTD2037EWE-TR](#)
[DIO5662ST6](#) [IS31BL3508A-TTLS2-TR](#) [KTD2026BEWE-TR](#) [MAX20052CATC/V+](#) [MAX25606AUP/V+](#) [BD6586MUV-E2](#) [BD9206EFV-E2](#) [BD9416FS-E2](#) [LYT4227E](#)