

NLAS5213

1 Ω R_{ON} DPST and Dual SPST Switches

The NLAS5213A and NLAS5213B are DPST and Dual SPST devices, respectively. They each consist of 2 single throw switches and are both designed for audio applications within portable devices. The NLAS5213A is controlled with a single enable pin while the NLAS5213B has two independent enables.

Both the NLAS5213A and NLAS5213B operate over a wide V_{CC} range, 1.65 V to 4.5 V, and maintain a very low R_{ON} : 1.3 Ω Max @ $V_{CC} = 4.2$ V. Each is available in a choice of two packages: US8 and UDFN8.

Features

- PST and Dual SPST Pinouts
- R_{ON} : 1.3 Ω Max @ $V_{CC} = 4.2$ V
- V_{CC} Range: 1.65 V to 4.5 V
- 8 kV Human Body Model ESD on I/O to GND
- UDFN8 or US8 Packages Available
- These are Pb-Free Devices

Typical Applications

- Mobile Phones
- Portable Devices



ON Semiconductor[®]

<http://onsemi.com>

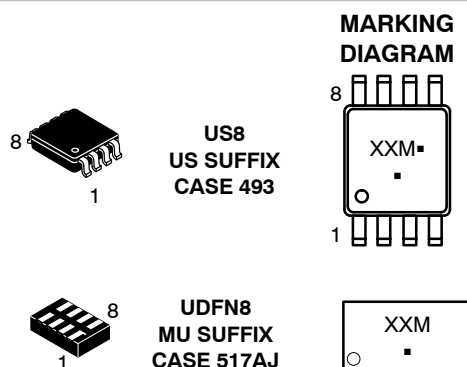

XX = Device Code
M = Date Code
▪ = Pb-Free Package

(Note: Microdot may be in either location)

APPLICATION DIAGRAM

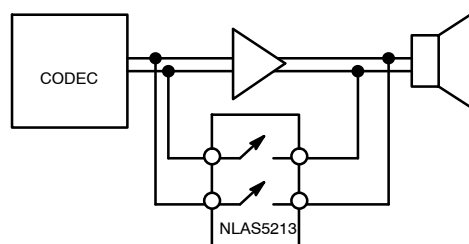

ORDERING INFORMATION

See detailed ordering, marking and shipping information in the package dimensions section on page 9 of this data sheet.

NLAS5213

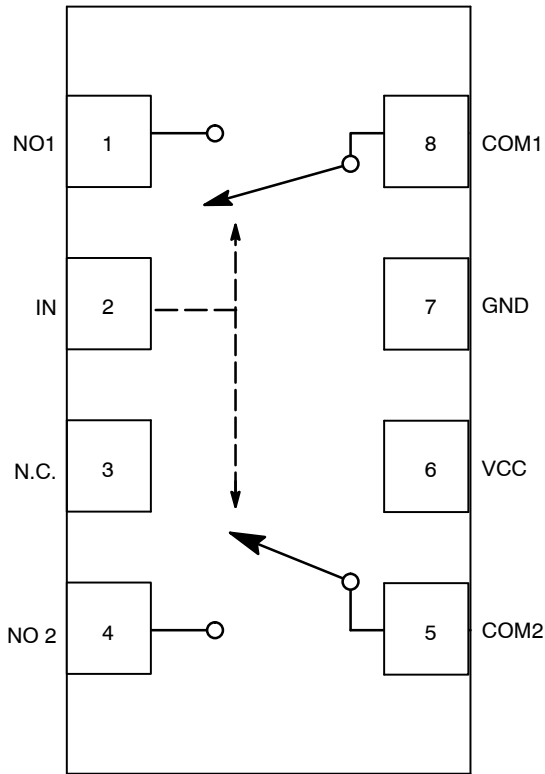

NLAS5213A

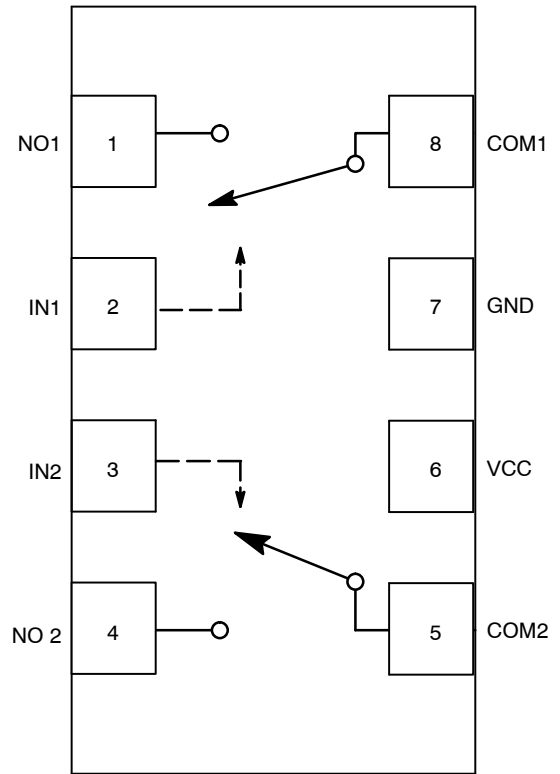

NLAS5213B

Figure 1. Functional Block Diagram Pinouts (UDFN8)

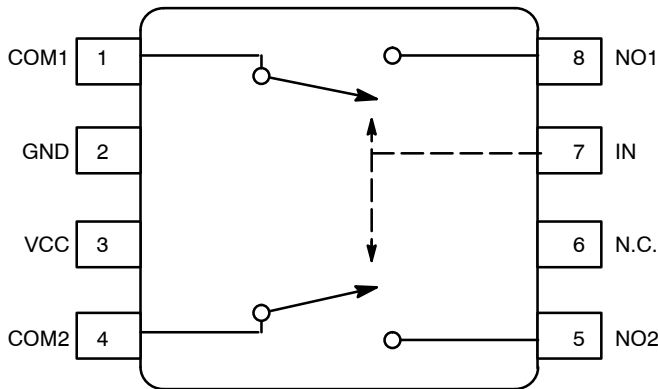

NLAS5213A

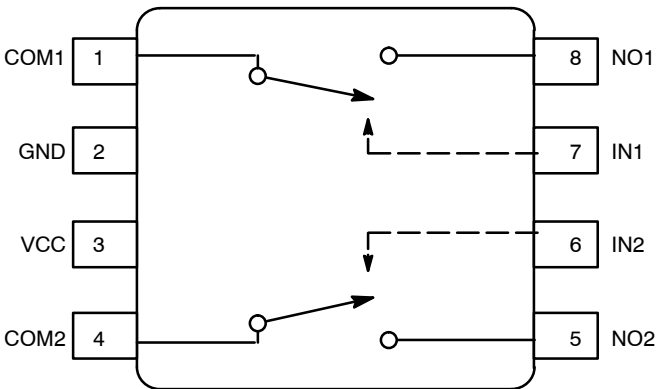

NLAS5213B

Figure 2. Functional Block Diagram Pinouts (US8)

NLAS5213

NLAS5213A

Pin #		Name	Direction	Description
UDFN8	US8			
1	8	NO1	I/O	Normally Open Signal Line of Switch 1
2	7	IN	Input	Control Input
3	6	N.C.	N/A	No Connect
4	5	NO2	I/O	Normally Open Signal Line of Switch 2
5	4	COM2	I/O	Common Signal Line of Switch 2
6	3	V _{CC}	Input	Analog Supply Voltage
7	2	GND	Input	Ground
8	1	COM1	I/O	Common Signal Line of Switch 1

NLAS5213B

Pin #		Name	Direction	Description
UDFN8	US8			
1	8	NO1	I/O	Normally Open Signal Line of Switch 1
2	7	IN1	Input	Control Input of Switch 1
3	6	IN2	Input	Control Input of Switch 2
4	5	NO2	I/O	Normally Open Signal Line of Switch 2
5	4	COM2	I/O	Common Signal Line of Switch 2
6	3	V _{CC}	Input	Analog Supply Voltage
7	2	GND	Input	Ground
8	1	COM1	I/O	Common Signal Line of Switch 1

NLAS5213A FUNCTION TABLE

IN	NO1, NO2
0	OFF
1	ON

NLAS5213B FUNCTION TABLE

IN	NO1, NO2
0	OFF
1	ON

NLAS5213

OPERATING CONDITIONS

MAXIMUM RATINGS

Symbol	Pins	Parameter	Value	Condition	Unit
V _{CC}	V _{CC}	Positive DC Supply Voltage	-0.5 to 5.5		V
V _{IS}	NOx, NCx, COMx	Analog Signal Voltage	-0.5 to V _{CC} + 0.5		V
V _{IN}	IN1, IN2	Control Input Voltage	-0.5 to 5.5		V
I _{CC}	V _{CC}	Positive DC Supply Current	50		mA
I _{IS_CON}	NOx, NCx, COMx	Analog Signal Continues Current	±300	Closed Switch	mA
I _{IS_PK}	NOx, NCx, COMx	Analog Signal Peak Current	±500	10% Duty Cycle	mA
I _{IN}	IN	Control Input Current	±20		mA
T _{STG}		Storage Temperature Range	-65 to 150		°C

Stresses exceeding Maximum Ratings may damage the device. Maximum Ratings are stress ratings only. Functional operation above the Recommended Operating Conditions is not implied. Extended exposure to stresses above the Recommended Operating Conditions may affect device reliability.

RECOMMENDED OPERATING CONDITIONS*

Symbol	Pins	Parameter	Value	Condition	Unit
V _{CC}	V _{CC}	Positive DC Supply Voltage	1.65 to 4.5		V
V _{IS}	NOx, NCx, COMx	Analog Signal Voltage	0 to V _{CC}		V
V _{IN}	IN1, IN2	Control Input Voltage	0 to V _{CC}		V
T _A		Operating Temperature Range	-40 to 85		°C

Minimum and maximum values are guaranteed through test or design across the **Recommended Operating Conditions**, where applicable. Typical values are listed for guidance only and are based on the particular conditions listed for each section, where applicable. These conditions are valid for all values found in the characteristics tables unless otherwise specified in the test conditions.

ESD PROTECTION

Symbol	Parameter	Value	Unit
ESD	Human Body Model I/O to GND All Pins	8.0 4.0	kV

DC ELECTRICAL CHARACTERISTICS

CONTROL INPUT (Typical: T = 25°C, V_{CC} = 3.3 V)

Symbol	Pins	Parameter	Test Conditions	V _{CC} (V)	-40°C to +85°C			Unit
					Min	Typ	Max	
V _{IH}	OE	Control Input HIGH Voltage		2.7 3.3 4.2	1.4 1.7 2.3	-	-	V
V _{IL}	OE	Control Input LOW Voltage		2.7 3.3 4.2	-	-	0.5 0.5 0.8	V
I _{IN}	OE	Control Input Leakage Current	0 ≤ V _{IS} ≤ V _{CC}	1.65 - 4.5	-	-	±1.0	μA

NLAS5213

SUPPLY CURRENT AND LEAKAGE (Typical: T = 25°C, V_{CC} = 3.3 V)

Symbol	Pins	Parameter	Test Conditions	V _{CC} (V)	-40°C to +85°C			Unit
					Min	Typ	Max	
I _{CC}	V _{CC}	Quiescent Supply Current	V _{IS} = V _{CC} or GND; I _D = 0 A	1.65 – 4.5	–	–	1.0	μA
I _{CC(T)}	V _{CC}	Increase in I _{CC} per Control Voltage	V _{IN} = 2.6 V	3.6	–	–	10.0	μA
I _{OZ}		OFF State Leakage	0 ≤ V _{IS} ≤ V _{CC}	1.65 – 4.5	–	–	±1.0	μA
I _{OFF}	D+, D–	Power OFF Leakage Current	0 ≤ V _{IS} ≤ V _{CC}	0	–	–	±1.0	μA

ON RESISTANCE (Typical: T = 25°C, V_{CC} = 3.3 V)

Symbol	Pins	Parameter	Test Conditions	V _{CC} (V)	-40°C to +85°C			Unit
					Min	Typ	Max	
R _{ON}		On-Resistance	I _{ON} = –100 mA V _{IS} = 0 to V _{CC}	2.7 3.3 4.2	–		2.0 1.4 1.3	Ω
R _{FLAT}		On-Resistance Flatness	I _{ON} = –100 mA V _{IS} = 0 to V _{CC}	2.7 3.3 4.2	–	0.32 0.35 0.37	–	Ω
ΔR _{ON}		On-Resistance Matching	I _{ON} = –100 mA V _{IS} = 0 to V _{CC}	2.7 3.3 4.2	–	0.16 0.16 0.15	–	Ω

AC ELECTRICAL CHARACTERISTICS

TIMING/FREQUENCY (Typical: T = 25°C, V_{CC} = 3.3 V, R_L = 50 Ω, C_L = 5 pF, f = 1 MHz)

Symbol	Pins	Parameter	Test Conditions	V _{CC} (V)	-40°C to +85°C			Unit
					Min	Typ	Max	
t _{ON}	Closed to Open	Turn-ON Time		1.65 – 4.5	–	20	–	ns
t _{OFF}	Open to Closed	Turn-OFF Time		1.65 – 4.5	–	15	–	ns
BW		–3 dB Bandwidth	C _L = 5 pF	1.65 – 4.5	–	496	–	MHz

ISOLATION (Typical: T = 25°C, V_{CC} = 3.3 V, R_L = 50 Ω, C_L = 5 pF, f = 1 MHz)

Symbol	Pins	Parameter	Test Conditions	V _{CC} (V)	-40°C to +85°C			Unit
					Min	Typ	Max	
O _{IRR}	Open	OFF-Isolation		1.65 – 4.5	–	–57	–	dB
X _{TALK}	HSD+, HSD–	Non-Adjacent Channel Crosstalk		1.65 – 4.5	–	–97	–	dB

CAPACITANCE (Typical: T = 25°C, V_{CC} = 3.3 V, R_L = 50 Ω, C_L = 5 pF, f = 1 MHz)

Symbol	Pins	Parameter	Test Conditions	-40°C to +85°C			Unit
				Min	Typ	Max	
C _{IN}	OE	Control Pin Input Capacitance	V _{CC} = 0 V	–	8.5	–	pF
C _{ON}	HSD+, to D+	ON Capacitance	V _{IN} = 0 V	–	32	–	pF
C _{OFF}	HSD+, HSD–	OFF Capacitance	V _{IS} = 3.3 V; V _{IN} = 3.3 V	–	19	–	pF

NLAS5213

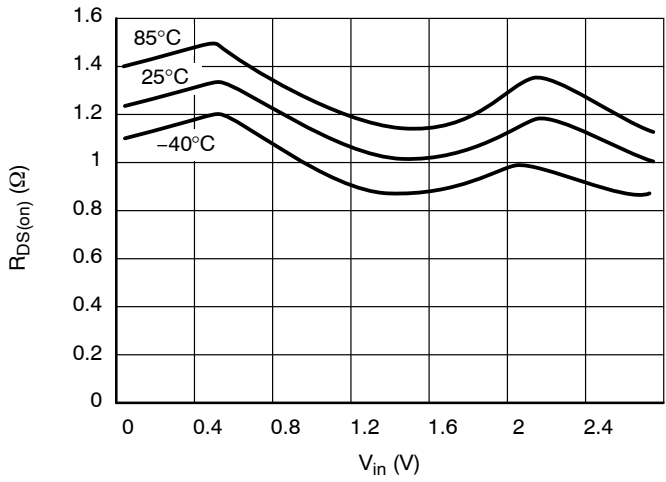

Figure 3. R_{ON} @ $V_{CC} = 2.7$ V

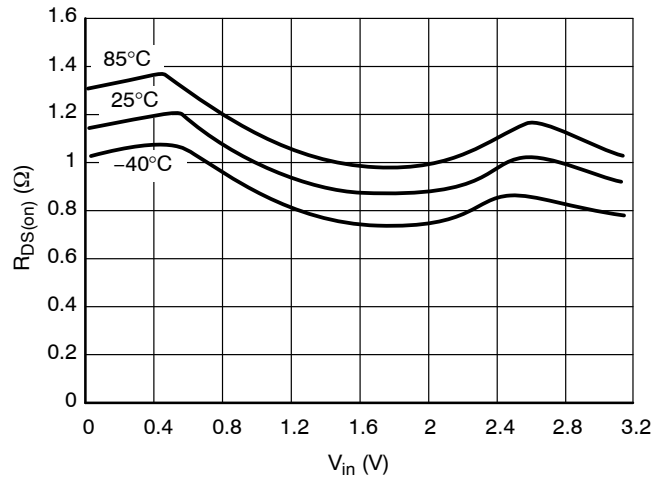

Figure 4. R_{ON} @ $V_{CC} = 3.3$ V

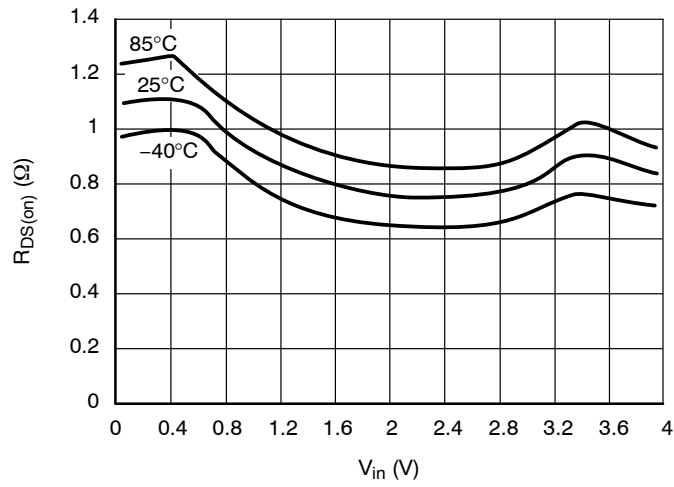

Figure 5. R_{ON} @ $V_{CC} = 4.2$ V

NLAS5213

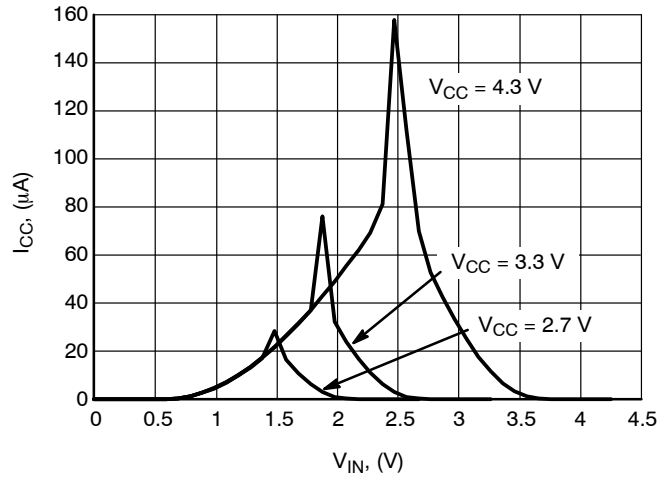

Figure 6. I_{CC} vs. V_{IN}

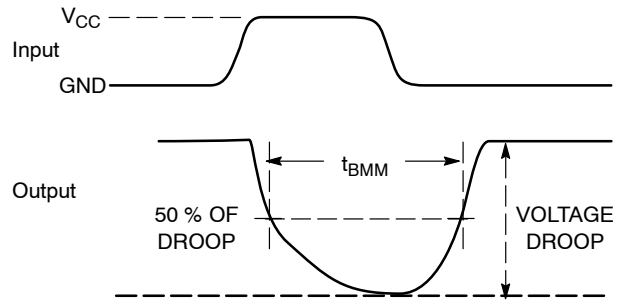
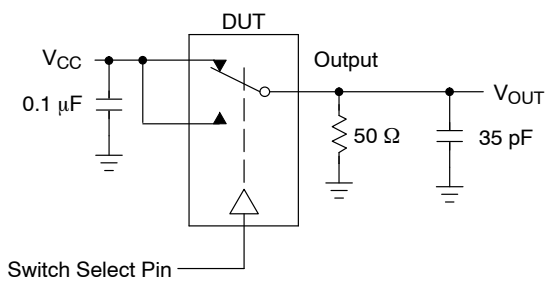

Figure 7. t_{BMM} (Time Break-Before-Make)

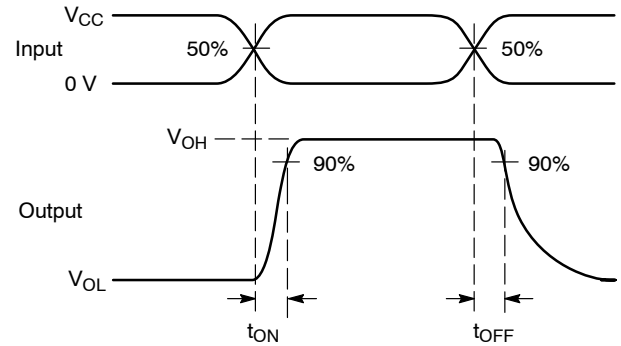
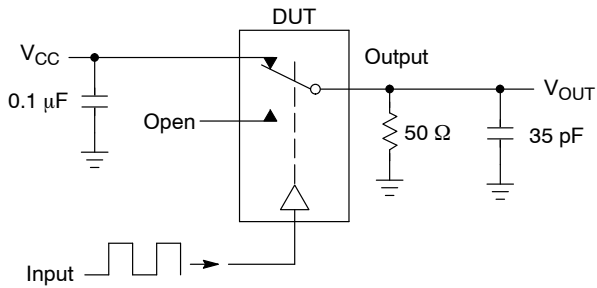

Figure 8. t_{ON}/t_{OFF}

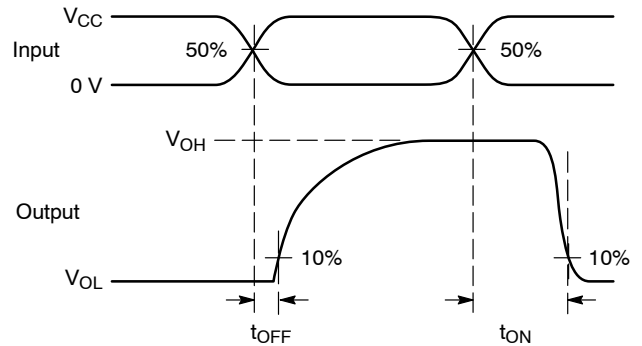
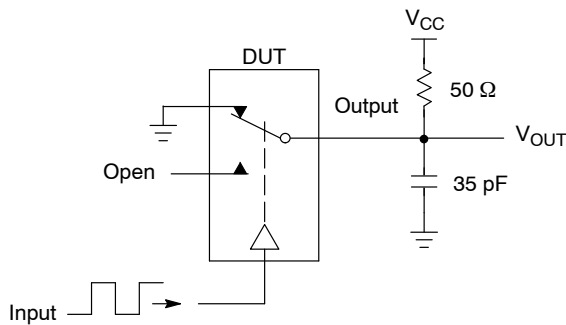
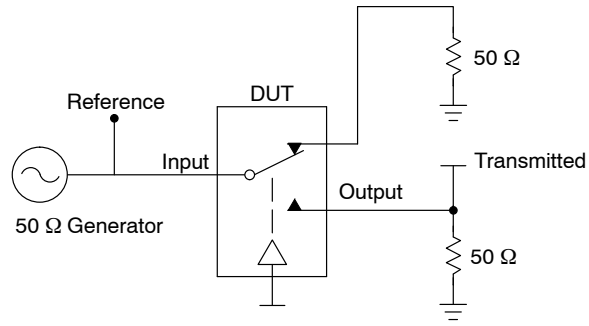

Figure 9. t_{ON}/t_{OFF}

NLAS5213



Channel switch control/s test socket is normalized. Off isolation is measured across an off channel. On loss is the bandwidth of an On switch. V_{ISO} , Bandwidth and V_{ONL} are independent of the input signal direction.

$$V_{ISO} = \text{Off Channel Isolation} = 20 \text{ Log} \left(\frac{V_{OUT}}{V_{IN}} \right) \text{ for } V_{IN} \text{ at } 100 \text{ kHz}$$

$$V_{ONL} = \text{On Channel Loss} = 20 \text{ Log} \left(\frac{V_{OUT}}{V_{IN}} \right) \text{ for } V_{IN} \text{ at } 100 \text{ kHz to } 50 \text{ MHz}$$

Bandwidth (BW) = the frequency 3 dB below V_{ONL}

V_{CT} = Use V_{ISO} setup and test to all other switch analog input/outputs terminated with 50 Ω

Figure 10. Off Channel Isolation/On Channel Loss (BW)/Crosstalk (On Channel to Off Channel)/ V_{ONL}

NLAS5213

DEVICE ORDERING INFORMATION

Device	Marking	Package Type	Shipping [†]
NLAS5213AUSG	VD	US8 (Pb-Free)	3,000 / Tape & Reel
NLAS5213AMUTAG	VD	UDFN8 (Pb-Free)	3,000 / Tape & Reel
NLAS5213BUSG	VE	US8 (Pb-Free)	3,000 / Tape & Reel
NLAS5213BMUTAG	VE	UDFN8 (Pb-Free)	3,000 / Tape & Reel

[†]For information on tape and reel specifications, including part orientation and tape sizes, please refer to our Tape and Reel Packaging Specifications Brochure, BRD8011/D.

MECHANICAL CASE OUTLINE PACKAGE DIMENSIONS

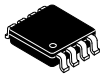

SCALE 4:1

US8
CASE 493
ISSUE F

DATE 01 SEP 2021

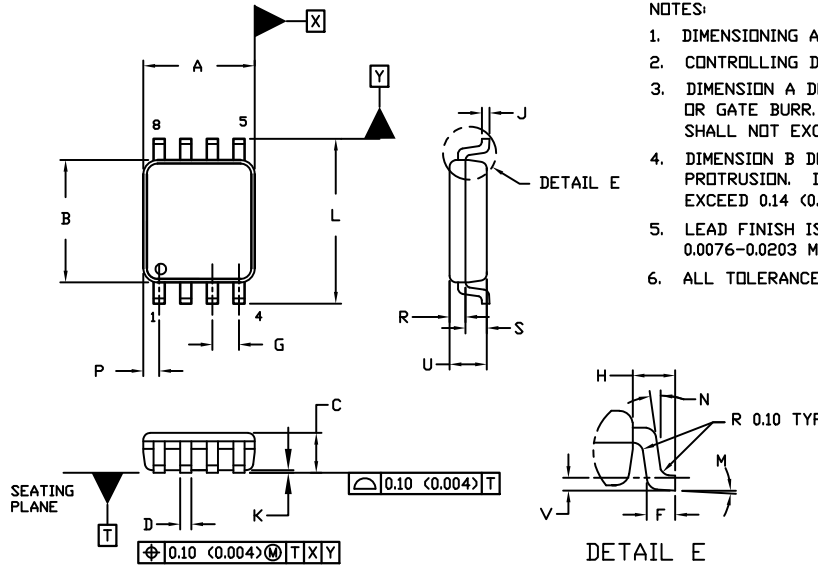

NOTES:

1. DIMENSIONING AND TOLERANCING PER ANSI Y14.5M, 1982.
2. CONTROLLING DIMENSION: MILLIMETERS
3. DIMENSION A DOES NOT INCLUDE MOLD FLASH, PROTRUSION, OR GATE BURR. MOLD FLASH, PROTRUSION, OR GATE BURR SHALL NOT EXCEED 0.14 (0.0055") PER SIDE.
4. DIMENSION B DOES NOT INCLUDE INTERLEAD FLASH OR PROTRUSION. INTERLEAD FLASH AND PROTRUSION SHALL NOT EXCEED 0.14 (0.0055") PER SIDE.
5. LEAD FINISH IS SOLDER PLATING WITH THICKNESS OF 0.0076-0.0203 MM (0.003-0.008").
6. ALL TOLERANCE UNLESS OTHERWISE SPECIFIED ±0.0508 MM (0.002").

DIM	MILLIMETERS		INCHES	
	MIN.	MAX.	MIN.	MAX.
A	1.90	2.10	0.075	0.083
B	2.20	2.40	0.087	0.094
C	0.60	0.90	0.024	0.035
D	0.17	0.25	0.007	0.010
F	0.20	0.35	0.008	0.014
G	0.50 BSC		0.020 BSC	
H	0.40 REF		0.016 REF	
J	0.10	0.18	0.004	0.007
K	0.00	0.10	0.000	0.004
L	3.00	3.25	0.118	0.128
M	0°	6°	0°	6°
N	0°	10°	0°	10°
P	0.23	0.34	0.010	0.013
R	0.23	0.33	0.009	0.013
S	0.37	0.47	0.015	0.019
U	0.60	0.80	0.024	0.031
V	0.12 BSC		0.005 BSC	

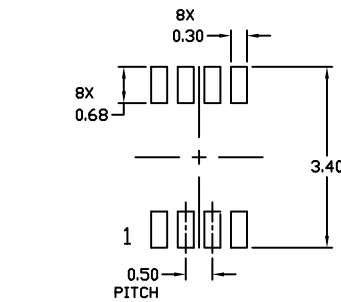

* For additional information on our Pb-Free strategy and soldering details, please download the DI Semiconductor Soldering and Mounting Techniques Reference Manual, SOLDERM/D.

GENERIC
MARKING DIAGRAM*

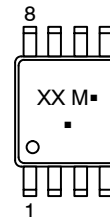

- XX = Specific Device Code
- M = Date Code
- = Pb-Free Package

(Note: Microdot may be in either location)

*This information is generic. Please refer to device data sheet for actual part marking. Pb-Free indicator, "G" or microdot "▪", may or may not be present. Some products may not follow the Generic Marking.

DOCUMENT NUMBER:	98AON04475D	Electronic versions are uncontrolled except when accessed directly from the Document Repository. Printed versions are uncontrolled except when stamped "CONTROLLED COPY" in red.
DESCRIPTION:	US8	PAGE 1 OF 1

onsemi and ONSEMI are trademarks of Semiconductor Components Industries, LLC dba onsemi or its subsidiaries in the United States and/or other countries. onsemi reserves the right to make changes without further notice to any products herein. onsemi makes no warranty, representation or guarantee regarding the suitability of its products for any particular purpose, nor does onsemi assume any liability arising out of the application or use of any product or circuit, and specifically disclaims any and all liability, including without limitation special, consequential or incidental damages. onsemi does not convey any license under its patent rights nor the rights of others.

MECHANICAL CASE OUTLINE

PACKAGE DIMENSIONS

ON Semiconductor®



SCALE 4:1

UDFN8 1.8x1.2, 0.4P
CASE 517AJ-01
ISSUE O

DATE 08 NOV 2006

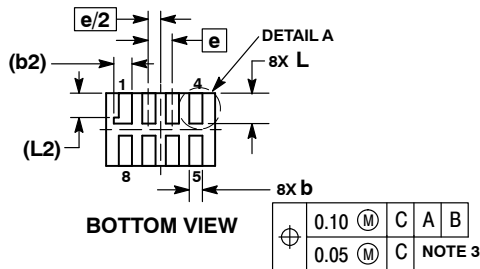
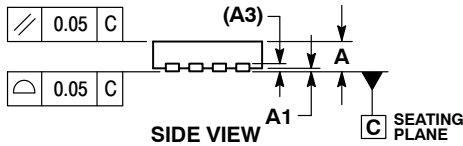
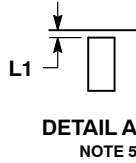
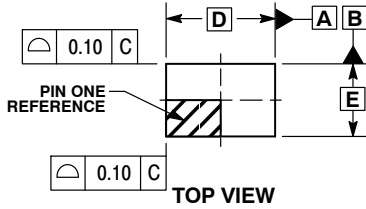

NOTES:

1. DIMENSIONING AND TOLERANCING PER ASME Y14.5M, 1994.
2. CONTROLLING DIMENSION: MILLIMETERS.
3. DIMENSION b APPLIES TO PLATED TERMINAL AND IS MEASURED BETWEEN 0.15 AND 0.30 mm FROM TERMINAL TIP.
4. MOLD FLASH ALLOWED ON TERMINALS ALONG EDGE OF PACKAGE. FLASH MAY NOT EXCEED 0.03 ONTO BOTTOM SURFACE OF TERMINALS.
5. DETAIL A SHOWS OPTIONAL CONSTRUCTION FOR TERMINALS.

MILLIMETERS		
DIM	MIN	MAX
A	0.45	0.55
A1	0.00	0.05
A3	0.127	REF
b	0.15	0.25
b2	0.30	REF
D	1.80	BSC
E	1.20	BSC
e	0.40	BSC
L	0.45	0.55
L1	0.00	0.03
L2	0.40	REF

GENERIC MARKING DIAGRAM*

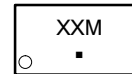

- XX = Specific Device Code
- M = Date Code
- = Pb-Free Package

MOUNTING FOOTPRINT
SOLDERMASK DEFINED

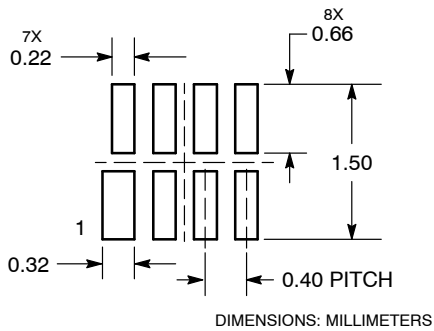

*This information is generic. Please refer to device data sheet for actual part marking. Pb-Free indicator, "G" or microdot "▪", may or may not be present.

DOCUMENT NUMBER:	98AON23417D	Electronic versions are uncontrolled except when accessed directly from the Document Repository. Printed versions are uncontrolled except when stamped "CONTROLLED COPY" in red.
DESCRIPTION:	UDFN8 1.8X1.2, 0.4P	PAGE 1 OF 1

ON Semiconductor and ON are trademarks of Semiconductor Components Industries, LLC dba ON Semiconductor or its subsidiaries in the United States and/or other countries. ON Semiconductor reserves the right to make changes without further notice to any products herein. ON Semiconductor makes no warranty, representation or guarantee regarding the suitability of its products for any particular purpose, nor does ON Semiconductor assume any liability arising out of the application or use of any product or circuit, and specifically disclaims any and all liability, including without limitation special, consequential or incidental damages. ON Semiconductor does not convey any license under its patent rights nor the rights of others.

onsemi, **Onsemi**, and other names, marks, and brands are registered and/or common law trademarks of Semiconductor Components Industries, LLC dba "**onsemi**" or its affiliates and/or subsidiaries in the United States and/or other countries. **onsemi** owns the rights to a number of patents, trademarks, copyrights, trade secrets, and other intellectual property. A listing of **onsemi**'s product/patent coverage may be accessed at www.onsemi.com/site/pdf/Patent-Marking.pdf. **onsemi** reserves the right to make changes at any time to any products or information herein, without notice. The information herein is provided "as-is" and **onsemi** makes no warranty, representation or guarantee regarding the accuracy of the information, product features, availability, functionality, or suitability of its products for any particular purpose, nor does **onsemi** assume any liability arising out of the application or use of any product or circuit, and specifically disclaims any and all liability, including without limitation special, consequential or incidental damages. Buyer is responsible for its products and applications using **onsemi** products, including compliance with all laws, regulations and safety requirements or standards, regardless of any support or applications information provided by **onsemi**. "Typical" parameters which may be provided in **onsemi** data sheets and/or specifications can and do vary in different applications and actual performance may vary over time. All operating parameters, including "Typicals" must be validated for each customer application by customer's technical experts. **onsemi** does not convey any license under any of its intellectual property rights nor the rights of others. **onsemi** products are not designed, intended, or authorized for use as a critical component in life support systems or any FDA Class 3 medical devices or medical devices with a same or similar classification in a foreign jurisdiction or any devices intended for implantation in the human body. Should Buyer purchase or use **onsemi** products for any such unintended or unauthorized application, Buyer shall indemnify and hold **onsemi** and its officers, employees, subsidiaries, affiliates, and distributors harmless against all claims, costs, damages, and expenses, and reasonable attorney fees arising out of, directly or indirectly, any claim of personal injury or death associated with such unintended or unauthorized use, even if such claim alleges that **onsemi** was negligent regarding the design or manufacture of the part. **onsemi** is an Equal Opportunity/Affirmative Action Employer. This literature is subject to all applicable copyright laws and is not for resale in any manner.

PUBLICATION ORDERING INFORMATION

LITERATURE FULFILLMENT:

Email Requests to: orderlit@onsemi.com

onsemi Website: www.onsemi.com

TECHNICAL SUPPORT

North American Technical Support:

Voice Mail: 1 800-282-9855 Toll Free USA/Canada

Phone: 011 421 33 790 2910

Europe, Middle East and Africa Technical Support:

Phone: 00421 33 790 2910

For additional information, please contact your local Sales Representative

X-ON Electronics

Largest Supplier of Electrical and Electronic Components

Click to view similar products for [Analogue Switch ICs category](#):

Click to view products by [ON Semiconductor manufacturer](#):

Other Similar products are found below :

[FSA3051TMX](#) [NLAS4684FCTCG](#) [NLAS5223BLMNR2G](#) [NLX2G66DMUTCG](#) [425541DB](#) [425528R](#) [099044FB](#) [NLAS5123MNR2G](#)
[PI5A4157CEX](#) [NLAS4717EPFCT1G](#) [PI5A3167CCEX](#) [SLAS3158MNR2G](#) [PI5A392AQE](#) [PI5A4157ZUEX](#) [PI5A3166TAEX](#) [FSA634UCX](#)
[XS3A1T3157GMX](#) [TC4066BP\(N,F\)](#) [DG302BDJ-E3](#) [PI5A100QEX](#) [HV2605FG-G](#) [HV2301FG-G](#) [RS2117YUTQK10](#) [RS2118YUTQK10](#)
[RS2227XUTQK10](#) [ADG452BRZ-REEL7](#) [MAX4066ESD+](#) [MAX391CPE+](#) [MAX4730EXT+T](#) [MAX314CPE+](#) [BU4066BCFV-E2](#)
[MAX313CPE+](#) [BU4S66G2-TR](#) [NLASB3157MTR2G](#) [TS3A4751PWR](#) [NLAST4599DFT2G](#) [NLAST4599DTT1G](#) [DG300BDJ-E3](#)
[DG2503DB-T2-GE1](#) [TC4W53FU\(Te12L,F\)](#) [HV2201FG-G](#) [74HC2G66DC.125](#) [DG3257DN-T1-GE4](#) [ADG619BRMZ-REEL](#)
[ADG1611BRUZ-REEL7](#) [DG2535EDQ-T1-GE3](#) [LTC201ACN#PBF](#) [74LV4066DB,118](#) [ISL43410IUZ](#) [FSA2275AUMX](#)