

NLAS7242

High-Speed USB 2.0 (480 Mbps) DPDT Switches

The NLAS7242 is a DPDT switch optimized for high-speed USB 2.0 applications within portable systems. It features ultra-low on capacitance, $C_{ON} = 7.5$ pF (typ), and a bandwidth above 950 MHz. It is optimized for applications that use a single USB interface connector to route multiple signal types. The C_{ON} and R_{ON} of both channels are suitably low to allow the NLAS7242 to pass any speed USB data or audio signals going to a moderately resistive terminal such as an external headset. The device is offered in a UQFN10 1.4 mm x 1.8 mm package.

Features

- Optimized Flow-Through Pinout
- R_{ON} : 5.0 Ω Typ @ $V_{CC} = 4.2$ V
- C_{ON} : 7.5 pF Typ @ $V_{CC} = 3.3$ V
- V_{CC} Range: 1.65 V to 4.5 V
- Typical Bandwidth: 950 MHz
- 1.4 mm x 1.8 mm x 0.50 mm UQFN10
- OVT on Common Signal Pins D+/D- up to 5.25 V
- 8 kV HBM ESD Protection on All Pins
- This is a Pb-Free Device

Typical Applications

- High Speed USB 2.0 Data
- Mobile Phones
- Portable Devices

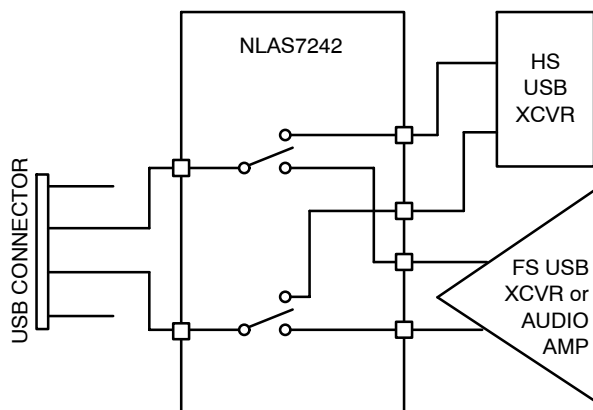

Figure 1. Application Diagram



ON Semiconductor®

<http://onsemi.com>

MARKING DIAGRAM

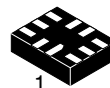

UQFN10
CASE 488AT

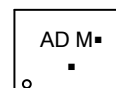

AD = Device Code
M = Date Code
■ = Pb-Free Device

(Note: Microdot may be in either location)

ORDERING INFORMATION

Device	Package	Shipping†
NLAS7242MUTBG	UQFN0 (Pb-Free)	3000/Tape & Reel

†For information on tape and reel specifications, including part orientation and tape sizes, please refer to our Tape and Reel Packaging Specification Brochure, BRD8011/D.

NLAS7242

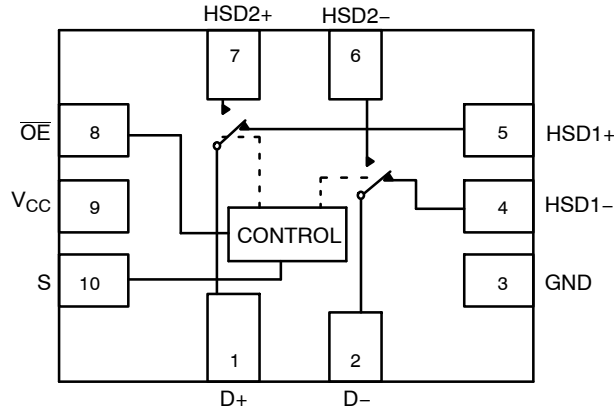

Figure 2. Pin Connections and Logic Diagram (Top View)

Table 1. PIN DESCRIPTION

Pin	Function
S	Control Input
\overline{OE}	Output Enable
HSD1+, HSD1-, HSD2+, HSD2-, D+, D-	Data Ports

Table 2. TRUTH TABLE

\overline{OE}	S	HSD1+, HSD1-	HSD2+, HSD2-
1	X	OFF	OFF
0	0	ON	OFF
0	1	OFF	ON

MAXIMUM RATINGS

Symbol	Pins	Parameter	Value	Unit
V_{CC}	V_{CC}	Positive DC Supply Voltage	-0.5 to +5.5	V
V_{IS}	HSDn+, HSDn-	Analog Signal Voltage	-0.5 to $V_{CC} + 0.3$	V
	D+, D-		-0.5 to +5.25	
V_{IN}	S, \overline{OE}	Control Input Voltage, Output Enable Voltage	-0.5 to +5.5	V
I_{CC}	V_{CC}	Positive DC Supply Current	50	mA
T_S		Storage Temperature	-65 to +150	°C
I_{IS_CON}	HSDn+, HSDn-, D+, D-	Analog Signal Continuous Current-Closed Switch	± 300	mA
I_{IS_PK}	HSDn+, HSDn-, D+, D-	Analog Signal Continuous Current 10% Duty Cycle	± 500	mA
I_{IN}	S, \overline{OE}	Control Input Current, Output Enable Current	± 20	mA

Stresses exceeding Maximum Ratings may damage the device. Maximum Ratings are stress ratings only. Functional operation above the Recommended Operating Conditions is not implied. Extended exposure to stresses above the Recommended Operating Conditions may affect device reliability.

RECOMMENDED OPERATING CONDITIONS

Symbol	Pins	Parameter	Min	Max	Unit
V_{CC}		Positive DC Supply Voltage	1.65	4.5	V
V_{IS}	HSDn+, HSDn-	Analog Signal Voltage	GND	V_{CC}	V
	D+, D-		GND	4.5	
V_{IN}	S, \overline{OE}	Control Input Voltage, Output Enable Voltage	GND	V_{CC}	V
T_A		Operating Temperature	-40	+85	°C

Minimum and maximum values are guaranteed through test or design across the Recommended Operating Conditions, where applicable. Typical values are listed for guidance only and are based on the particular conditions listed for section, where applicable. These conditions are valid for all values found in the characteristics tables unless otherwise specified in the test conditions.

ESD PROTECTION

Symbol	Parameter	Value	Unit
ESD	Human Body Model - All Pins	8.0	kV

DC ELECTRICAL CHARACTERISTICS

CONTROL INPUT, OUTPUT ENABLE VOLTAGE (Typical: T = 25°C)

Symbol	Pins	Parameter	Test Conditions	V _{CC} (V)	-40°C to +85°C			Unit
					Min	Typ	Max	
V _{IH}	S, \overline{OE}	Control Input, Output Enable HIGH Voltage (See Figure 11)		2.7	1.25	-	-	V
				3.3	1.3			
				4.2	1.4			
V _{IL}	S, \overline{OE}	Control Input, Output Enable LOW Voltage (See Figure 11)		2.7	-	-	0.35	V
				3.3			0.4	
				4.2			0.5	
I _{IN}	S, \overline{OE}	Current Input, Output Enable Leakage Current	0 ≤ V _{IS} ≤ V _{CC}	1.65 – 4.5	-	-	±1.0	μA

SUPPLY CURRENT AND LEAKAGE (Typical: T = 25°C, V_{CC} = 3.3 V)

Symbol	Pins	Parameter	Test Conditions	V _{CC} (V)	-40°C to +85°C			Unit
					Min	Typ	Max	
I _{CC}	V _{CC}	Quiescent Supply Current	0 ≤ V _{IS} ≤ V _{CC} ; I _D = 0 A	1.65 – 3.6	-	-	1.0	μA
			0 ≤ V _{IS} ≤ V _{CC} - 0.5 V	3.6 – 4.5	-	-	1.0	
I _{OZ}		OFF State Leakage	0 ≤ V _{IS} ≤ V _{CC}	1.65 – 4.5	-	±0.1	±1.0	μA
I _{OFF}	D+, D-	Power OFF Leakage Current	0 ≤ V _{IS} ≤ V _{CC}	0	-	-	±1.0	μA

LIMITED V_{IS} SWING ON RESISTANCE (Typical: T = 25°C)

Symbol	Pins	Parameter	Test Conditions	V _{CC} (V)	-40°C to +85°C			Unit
					Min	Typ	Max	
R _{ON}		On-Resistance (Note 1)	I _{ON} = 8 mA V _{IS} = 0 V to 0.4 V	2.7	-	6.0	8.6	Ω
				3.3		5.5	7.6	
				4.2		5.0	7.0	
R _{FLAT}		On-Resistance Flatness (Notes 1 and 2)	I _{ON} = 8 mA V _{IS} = 0 V to 0.4 V	2.7	-	0.55	-	Ω
				3.3		0.30		
				4.2		0.20		
ΔR _{ON}		On-Resistance Matching (Notes 1 and 3)	I _{ON} = 8 mA V _{IS} = 0 V to 0.4 V	2.7	-	0.60	-	Ω
				3.3		0.60		
				4.2		0.60		

1. Guaranteed by design.
2. Flatness is defined as the difference between the maximum and minimum value of On-Resistance as measured over the specified analog signal ranges.
3. ΔR_{ON} = R_{ON(max)} - R_{ON(min)} between HSD1+ and HSD1- or HSD2+ and HSD2-.

FULL V_{IS} SWING ON RESISTANCE (Typical: T = 25°C)

Symbol	Pins	Parameter	Test Conditions	V _{CC} (V)	-40°C to +85°C			Unit
					Min	Typ	Max	
R _{ON}		On-Resistance	I _{ON} = 8 mA V _{IS} = 0 V to V _{CC}	2.7	-	10	13.5	Ω
				3.3		8.0	9.75	
				4.2		7.0	8.50	
R _{FLAT}		On-Resistance Flatness (Notes 4 and 5)	I _{ON} = 8 mA V _{IS} = 0 V to V _{CC}	2.7	-	4.5	-	Ω
				3.3		3.0		
				4.2		2.5		
ΔR _{ON}		On-Resistance (Note 4 and 6)	I _{ON} = 8 mA V _{IS} = 0 V to V _{CC}	2.7	-	0.60	-	Ω
				3.3		0.60		
				4.2		0.60		

4. Guaranteed by design.
5. Flatness is defined as the difference between the maximum and minimum value of On-Resistance as measured over the specified analog signal ranges.
6. ΔR_{ON} = R_{ON(max)} - R_{ON(min)} between HSD1+ and HSD1- or HSD2+ and HSD2-.

NLAS7242

AC ELECTRICAL CHARACTERISTICS

TIMING/FREQUENCY (Typical: T = 25°C, V_{CC} = 3.3 V, R_L = 50 Ω, C_L = 35 pF, f = 1 MHz)

Symbol	Pins	Parameter	Test Conditions	V _{CC} (V)	-40°C to +85°C			Unit
					Min	Typ	Max	
t _{ON}	Closed to Open	Turn-ON Time (See Figures 4 and 5)		1.65 – 4.5	–	13.0	30.0	ns
t _{OFF}	Open to Closed	Turn-OFF Time (See Figures 4 and 5)		1.65 – 4.5	–	12.0	25.0	ns
T _{BBM}		Break-Before-Make Time (See Figure 3)		1.65 – 4.5	2.0	–	–	ns
BW		-3 dB Bandwidth (See Figure 10)	C _L = 5 pF	1.65 – 4.5	–	950	–	MHz

ISOLATION (Typical: T = 25°C, V_{CC} = 3.3 V, R_L = 50 Ω, C_L = 5 pF)

Symbol	Pins	Parameter	Test Conditions	V _{CC} (V)	-40°C to +85°C			Unit
					Min	Typ	Max	
O _{IRR}	Open	OFF-Isolation (See Figure 6)	f = 240 MHz	1.65 – 4.5	–	-22	–	dB
X _{TALK}	HSDn+ to HSDn-	Non-Adjacent Channel Crosstalk	f = 240 MHz	1.65 – 4.5	–	-24	–	dB

CAPACITANCE (Typical: T = 25°C, V_{CC} = 3.3 V, R_L = 50 Ω, C_L = 5 pF)

Symbol	Pins	Parameter	Test Conditions	-40°C to +85°C			Unit
				Min	Typ	Max	
C _{IN}	S, \overline{OE}	Control Pin, Output Enable Input Capacitance	V _{CC} = 0 V, f = 1 MHz	–	1.5	–	pF
			V _{CC} = 0 V, f = 10 MHz	–	1.0	–	
C _{ON}	D+ to HSD1+ or HSD2+	ON Capacitance	V _{CC} = 3.3 V; \overline{OE} = 0 V, f = 1 MHz S = 0 V or 3.3 V	–	7.5	–	pF
			V _{CC} = 3.3 V; \overline{OE} = 0 V, f = 10 MHz S = 0 V or 3.3 V	–	6.5	–	
C _{OFF}	HSD1n or HSD2n	OFF Capacitance	V _{CC} = V _{IS} = 3.3 V; \overline{OE} = 0 V, S = 3.3 V or 0 V, f = 1 MHz	–	3.8	–	pF
			V _{CC} = V _{IS} = 3.3 V; \overline{OE} = 0 V, S = 3.3 V or 0 V, f = 10 MHz	–	2.0	–	

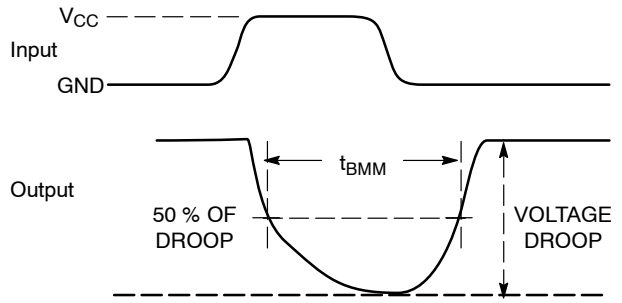
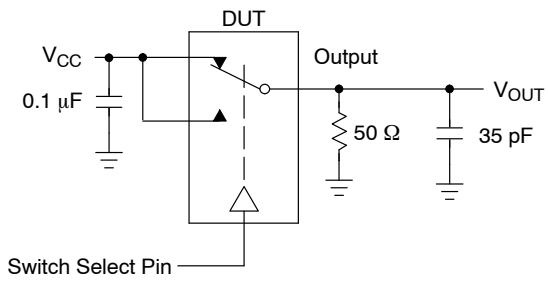

Figure 3. t_{BMM} (Time Break-Before-Make)

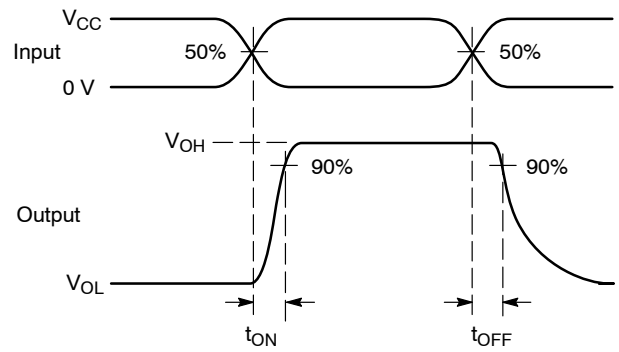
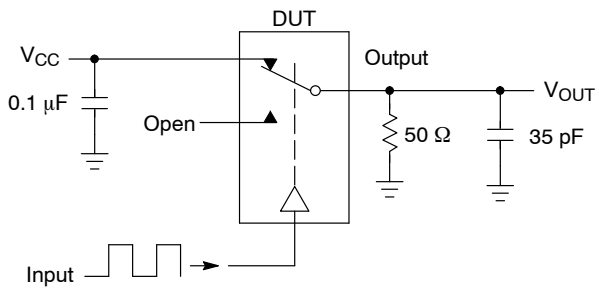

Figure 4. t_{ON}/t_{OFF}

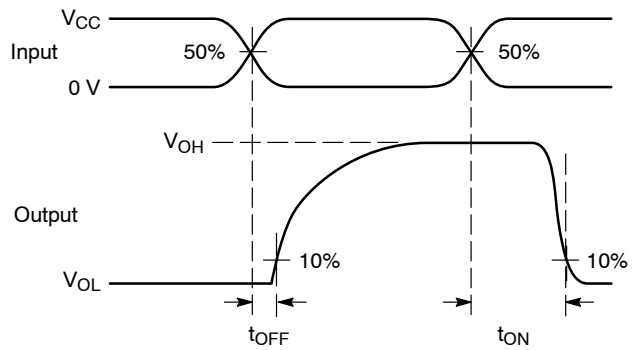
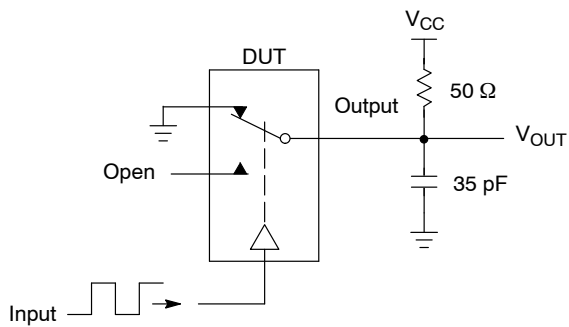
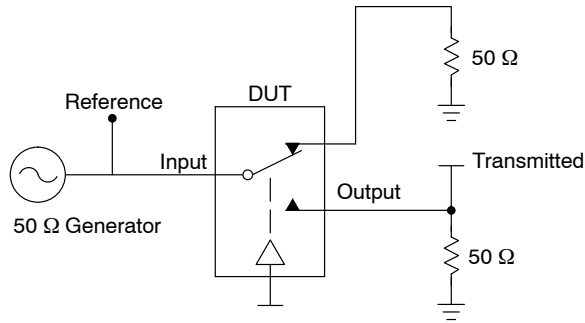

Figure 5. t_{ON}/t_{OFF}

NLAS7242



Channel switch control/s test socket is normalized. Off isolation is measured across an off channel. On loss is the bandwidth of an On switch. V_{ISO} , Bandwidth and V_{ONL} are independent of the input signal direction.

$$V_{ISO} = \text{Off Channel Isolation} = 20 \text{ Log} \left(\frac{V_{OUT}}{V_{IN}} \right) \text{ for } V_{IN} \text{ at } 100 \text{ kHz}$$

$$V_{ONL} = \text{On Channel Loss} = 20 \text{ Log} \left(\frac{V_{OUT}}{V_{IN}} \right) \text{ for } V_{IN} \text{ at } 100 \text{ kHz to } 50 \text{ MHz}$$

Bandwidth (BW) = the frequency 3 dB below V_{ONL}

V_{CT} = Use V_{ISO} setup and test to all other switch analog input/outputs terminated with 50 Ω

Figure 6. Off Channel Isolation/On Channel Loss (BW)/Crosstalk (On Channel to Off Channel)/ V_{ONL}

DETAILED DESCRIPTION

High Speed (480Mbps) USB 2.0 Optimized

The NLAS7242 is a DPDT switch designed for USB applications within portable systems. The R_{ON} and C_{ON} of both switches are maintained at industry-leading low levels in order to ensure maximum signal integrity for USB 2.0 high speed data communication. The NLAS7242 switch can be used to switch between high speed (480Mbps) USB signals and a variety of audio or data signals such as full speed USB, UART or even a moderately resistive audio terminal.

Over Voltage Tolerant

The NLAS7242 features over voltage tolerant I/O protection on the common signal pins D+/D-. This allows the switch to interface directly with a USB connector. The D+/D- pins can withstand a short to V_{BUS} , up to 5.25 V, continuous DC current for up to 24 hours as specified in the USB 2.0 specification. This protection is achieved without the need for any external resistors or protection devices.

NLAS7242

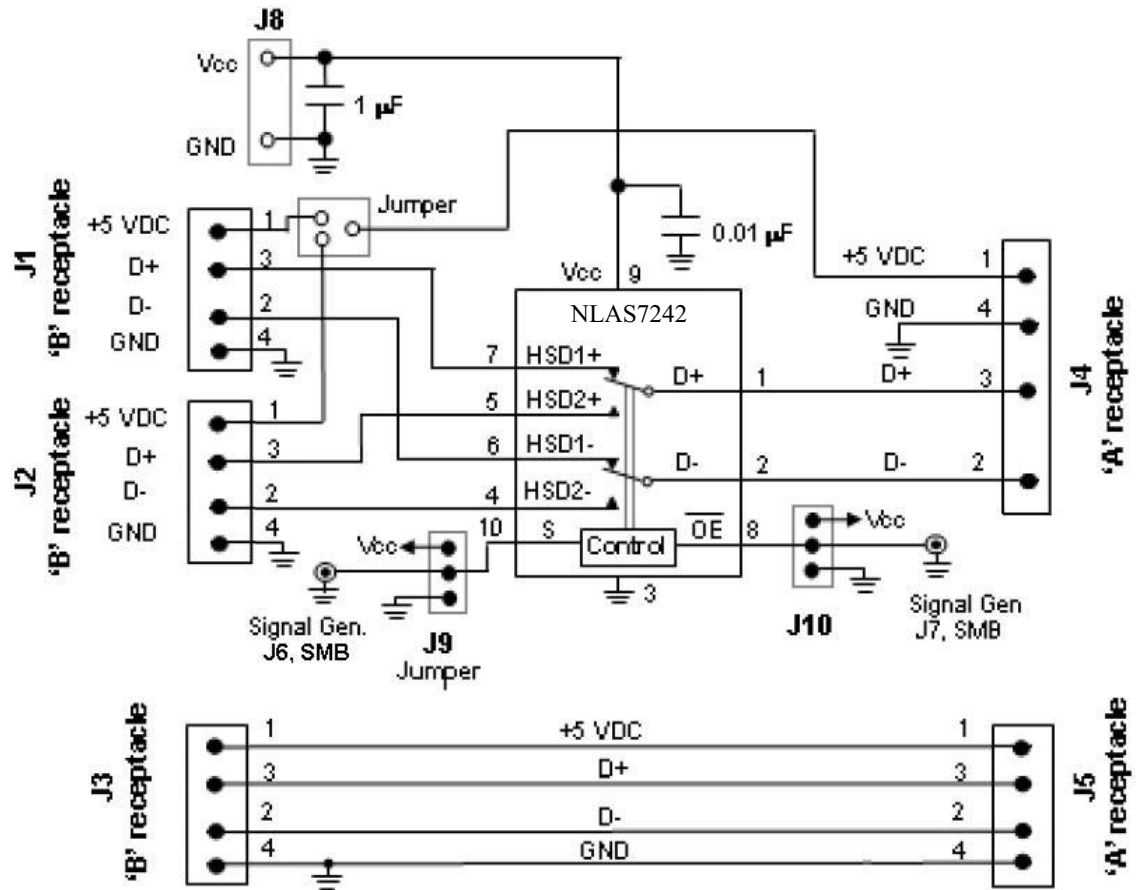

Figure 7. Board Schematic

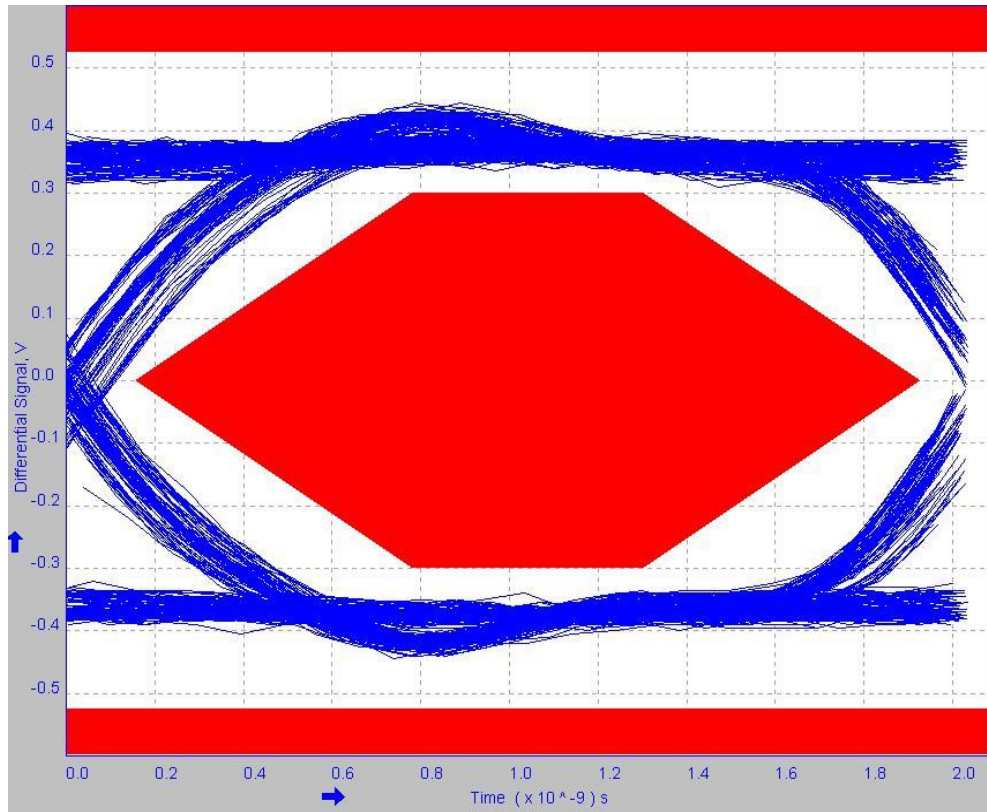

Figure 8. Signal Quality

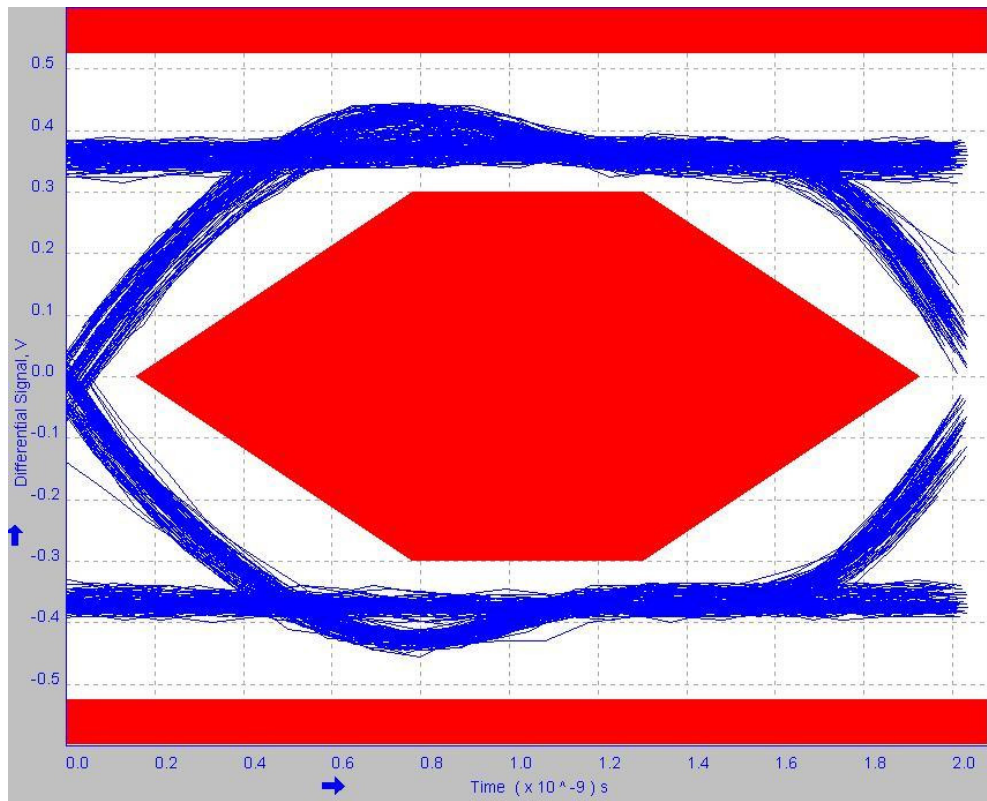
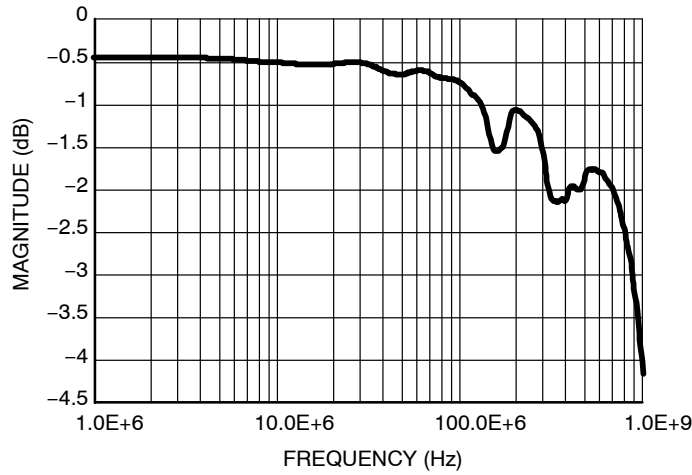

Figure 9. Near End Eye Diagram

NLAS7242

Near End Test Data:					Min	Max
Std.	Consecutive jitter range	-54.37	73.21	ps	-200 ps	+200 ps
	Paired JK jitter range	-59.14	59.56	ps		
	Paired KJ jitter range	-50.79	34.57	ps		
N.C.	Consecutive jitter range	-74.43	81.65	ps	-200 ps	+200 ps
	Paired JK jitter range	-61.60	58.55	ps		
	Paired KJ jitter range	-55.31	48.43	ps		
N.O.	Consecutive jitter range	-82.55	80.33	ps	-200 ps	+200 ps
	Paired JK jitter range	-53.50	71.65	ps		
	Paired KJ jitter range	-62.60	47.30	ps		



**Figure 10. Magnitude vs. Frequency
@ V_{CC} = 3.3 V, All Temperatures**

I_{CC} Leakage Current as a Function of V_{IN} Voltage (25°C)

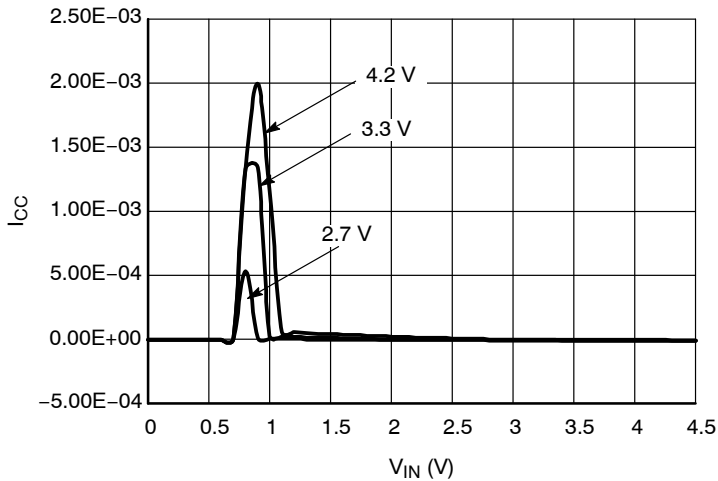
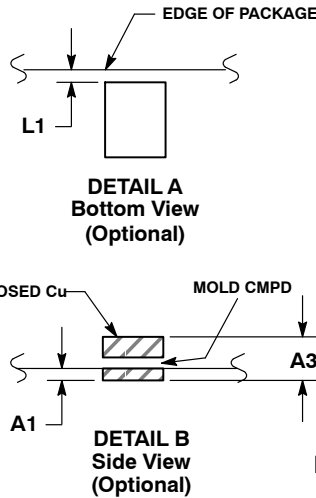
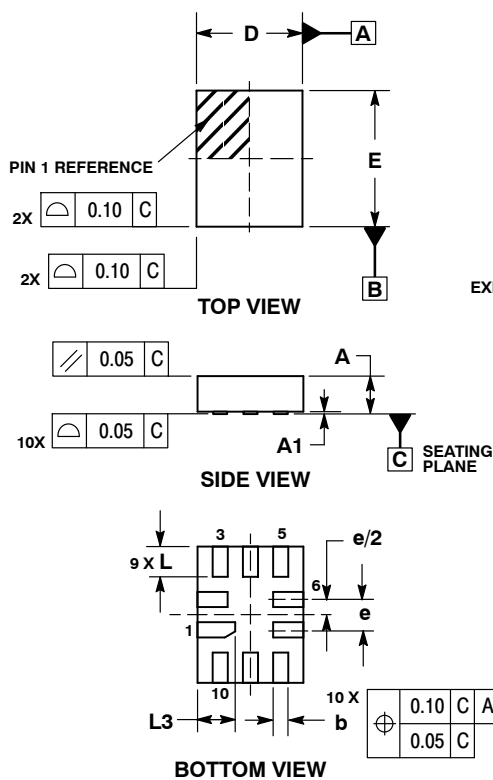

Figure 11. I_{CC} vs. V_{IN}, Select Pin, All V_{CC}'s, 25°C

NLAS7242

PACKAGE DIMENSIONS

UQFN10 1.4x1.8, 0.4P
CASE 488AT-01
ISSUE A



NOTES:

1. DIMENSIONING AND TOLERANCING PER ASME Y14.5M, 1994.
2. CONTROLLING DIMENSION: MILLIMETERS
3. DIMENSION b APPLIES TO PLATED TERMINAL AND IS MEASURED BETWEEN 0.25 AND 0.30 MM FROM TERMINAL.
4. COPLANARITY APPLIES TO THE EXPOSED PAD AS WELL AS THE TERMINALS.

MILLIMETERS		
DIM	MIN	MAX
A	0.45	0.60
A1	0.00	0.05
A3	0.127 REF	
b	0.15	0.25
D	1.40 BSC	
E	1.80 BSC	
e	0.40 BSC	
L	0.30	0.50
L1	0.00	0.15
L3	0.40	0.60

MOUNTING FOOTPRINT*

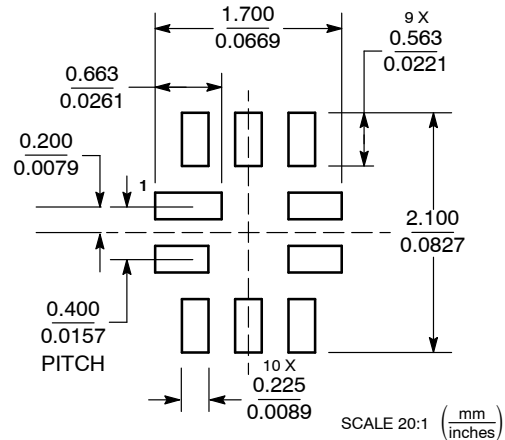

*For additional information on our Pb-Free strategy and soldering details, please download the ON Semiconductor Soldering and Mounting Techniques Reference Manual, SOLDERM/D.

ON Semiconductor and are registered trademarks of Semiconductor Components Industries, LLC (SCILLC). SCILLC reserves the right to make changes without further notice to any products herein. SCILLC makes no warranty, representation or guarantee regarding the suitability of its products for any particular purpose, nor does SCILLC assume any liability arising out of the application or use of any product or circuit, and specifically disclaims any and all liability, including without limitation special, consequential or incidental damages. "Typical" parameters which may be provided in SCILLC data sheets and/or specifications can and do vary in different applications and actual performance may vary over time. All operating parameters, including "Typicals" must be validated for each customer application by customer's technical experts. SCILLC does not convey any license under its patent rights nor the rights of others. SCILLC products are not designed, intended, or authorized for use as components in systems intended for surgical implant into the body, or other applications intended to support or sustain life, or for any other application in which the failure of the SCILLC product could create a situation where personal injury or death may occur. Should Buyer purchase or use SCILLC products for any such unintended or unauthorized application, Buyer shall indemnify and hold SCILLC and its officers, employees, subsidiaries, affiliates, and distributors harmless against all claims, costs, damages, and expenses, and reasonable attorney fees arising out of, directly or indirectly, any claim of personal injury or death associated with such unintended or unauthorized use, even if such claim alleges that SCILLC was negligent regarding the design or manufacture of the part. SCILLC is an Equal Opportunity/Affirmative Action Employer. This literature is subject to all applicable copyright laws and is not for resale in any manner.

PUBLICATION ORDERING INFORMATION

LITERATURE FULFILLMENT:
 Literature Distribution Center for ON Semiconductor
 P.O. Box 5163, Denver, Colorado 80217 USA
Phone: 303-675-2175 or 800-344-3860 Toll Free USA/Canada
Fax: 303-675-2176 or 800-344-3867 Toll Free USA/Canada
Email: orderlit@onsemi.com

N. American Technical Support: 800-282-9855 Toll Free USA/Canada
Europe, Middle East and Africa Technical Support:
 Phone: 421 33 790 2910
Japan Customer Focus Center
 Phone: 81-3-5773-3850

ON Semiconductor Website: www.onsemi.com
Order Literature: <http://www.onsemi.com/orderlit>

For additional information, please contact your local Sales Representative

X-ON Electronics

Largest Supplier of Electrical and Electronic Components

Click to view similar products for [Switch IC Development Tools](#) category:

Click to view products by [ON Semiconductor](#) manufacturer:

Other Similar products are found below :

[EVAL-ADG2108EBZ](#) [MIC2039-1AYM6 EV](#) [TPS2061EVM-292](#) [TPS2020EVM-290](#) [MAX4993EVKIT+](#) [MAX4885EEVKIT](#)
[MAX4983EEVKIT+](#) [MAX4948EVKIT+](#) [MAX14986EVKIT#](#) [MAX14808EVSYS#](#) [NS3L500MTGEVB](#) [MAX14566EEVKIT#](#)
[MAX16969EVKIT+](#) [MAX4986EVKIT+](#) [ISL54059EVAL1Z](#) [MAX4989EVKIT+](#) [MAX4754AEVKIT+](#) [TPS2062-1EVM-293](#)
[FUSB302TGEVB](#) [FSA515GEVB](#) [ADRF5043-EVALZ](#) [EVAL-ADGM1304SDZ](#) [MAX12005EVKIT#](#) [MAX14983EEVKIT#](#)
[MAX14589EEVKIT#](#) [EV-ADGS1414DSDZ](#) [EVAL-ADG5401FEBZ](#) [TPS1H100EVM](#) [TPS2041BEVM](#) [TPS2041BEVM-292](#)
[TPS2051BEVM](#) [TPS2066EVM-293](#) [TPS2560DRCEVM-424](#) [TSU6721EVM](#) [BOB-09056](#) [UPD5713TK-EVAL-A](#) [EVAL-ADG2188EBZ](#)
[EVAL-ADG5209FEBZ](#) [EVAL-ADG5208FEBZ](#) [EVAL-ADG5404FEBZ](#) [MIC2039-05AYMT-EV](#) [ADP196CP-EVALZ](#) [EKIT01-](#)
[HMC1027BG](#) [MAX1978EVKIT](#) [TPS2561DRCEVM-424](#) [TPS2024EVM-290](#) [2717](#) [ISL54220IRUEVAL1Z](#) [ZXFV302EV](#)
[TS3USB221AEVM](#)