

NLSV22T244

Dual 2-Bit Dual-Supply Non-Inverting Level Translator

The NLSV22T244 is a dual 2-bit configurable dual-supply bus buffer level translator. The input ports A and the output ports B are designed to track two different power supply rails V_{CCA} and V_{CCB} . Both supply rails are configurable from 1.6 V to 3.6 V allowing universal low-voltage translations from the input port A to the output B port.

Features

- Wide V_{CCA} and V_{CCB} Operating Range: 1.6 V to 3.6 V
- High-Speed w/ Balanced Propagation Delay
- Inputs and Outputs have OVT Protection to 5.5 V
- Non-preferential V_{CCA} and V_{CCB} Sequencing
- Outputs at 3-State until Active V_{CC} is reached
- Power-Off Protection
- Ultra-Small packaging: 1.7mm x 2.0 mm UQFN-12
- This is a Pb-Free Device

Typical Applications

- Mobile Phones, PDAs, Other Portable Devices

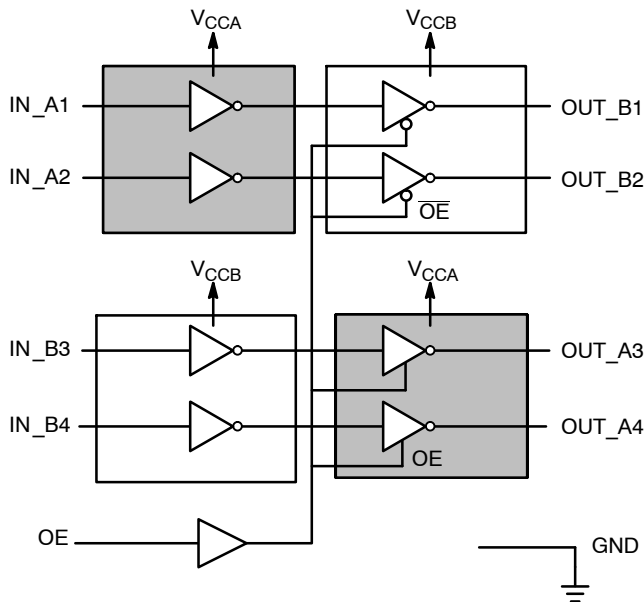
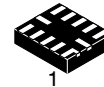

Figure 1. Logic Diagram



ON Semiconductor®

<http://onsemi.com>



UQFN12
MU SUFFIX
CASE 523AE

MARKING DIAGRAM

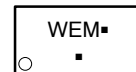

WE = Specific Device Code

M = Date Code

▪ = Pb-Free Package

(Note: Microdot may be in either location)

PIN ASSIGNMENT

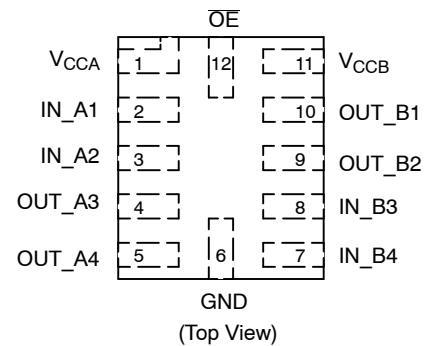

ORDERING INFORMATION

Device	Package	Shipping†
NLSV22T244MUTAG	UQFN12 (Pb-Free) / Tape & Reel	3000

† For information on tape and reel specifications, including part orientation and tape sizes, please refer to our Tape and Reel Packaging Specification Brochure, BRD8011/D.

NLSV22T244

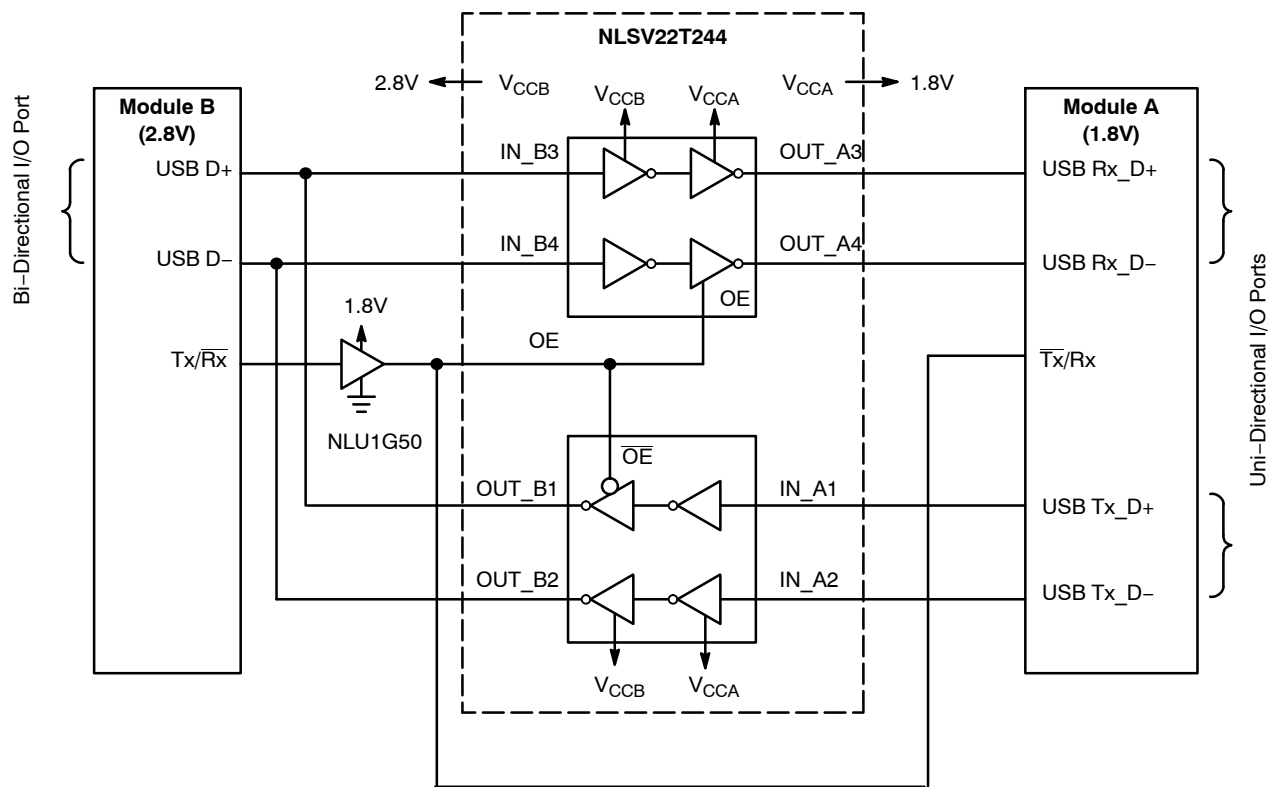

OE = High, Module B Transmits, Module A Receives = B → A

OE = Low, Module A Transmits, Module B Receives = A → B

Figure 2. Typical Application Bi-Directional to Uni-Directional Logic Level Translator

NLSV22T244

PIN ASSIGNMENT

Pin	Function
V _{CCA}	A DC Power Supply
V _{CCB}	B DC Power Supply
GND	Ground
IN_A1, IN_A2, IN_B3, IN_B4	Inputs
OUT_B1, OUT_B2, OUT_A3, OUT_A4	Outputs
OE	Output Enable

Inputs			Outputs	
OE	IN_A1 IN_A2	IN_B3, IN_B4	OUT_B1, OUT_B2	OUT_A3 OUT_A4
H	X	L	3-State	L
	L	H		H
L	L	X	L	3-State
	H		H	

MAXIMUM RATINGS

Symbol	Rating	Value	Condition	Unit
V _{CCA} , V _{CCB}	DC Supply Voltage	-0.5 to +5.5		V
V _I	DC Input Voltage IN_X _n	-0.5 to +5.5		V
V _C	Control Input OE	-0.5 to +5.5		V
V _O	DC Output Voltage (Power Down) OUT_X _n	-0.5 to +5.5	V _{CCA} = V _{CCB} = 0	V
	(Active Mode) OUT_X _n	-0.5 to +5.5		
	(Tri-State Mode) OUT_X _n	-0.5 to +5.5		
I _{IK}	DC Input Diode Current	-20	V _I < GND	mA
I _{OK}	DC Output Diode Current	-50	V _O < GND	mA
I _O	DC Output Source/Sink Current	±50		mA
I _{CCA} , I _{CCB}	DC Supply Current Per Supply Pin	±100		mA
I _{GND}	DC Ground Current per Ground Pin	±100		mA
T _{STG}	Storage Temperature	-65 to +150		°C

Stresses exceeding Maximum Ratings may damage the device. Maximum Ratings are stress ratings only. Functional operation above the Recommended Operating Conditions is not implied. Extended exposure to stresses above the Recommended Operating Conditions may affect device reliability.

RECOMMENDED OPERATING CONDITIONS

Symbol	Parameter	Min	Max	Unit
V _{CCA} , V _{CCB}	Positive DC Supply Voltage	1.6	3.6	V
V _I	Bus Input Voltage	GND	3.6	V
V _C	Control Input OE	GND	3.6	V
V _{IO}	Bus Output Voltage (Power Down Mode) OUT_X _n	GND	3.6	V
	(Active Mode) OUT_X _n	GND	3.6	V
	(Tri-State Mode) OUT_X _n	GND	3.6	V
T _A	Operating Temperature Range	-40	+85	°C
Δt / ΔV	Input Transition Rise or Rate V _I , from 30% to 70% of V _{CC} ; V _{CC} = 3.3 V ±0.3 V	0	10	nS

NLSV22T244

DC ELECTRICAL CHARACTERISTICS

Symbol	Parameter	Test Conditions	V _{CCA} (V)	V _{CCB} (V)	-40°C to +85°C		Unit
					Min	Max	
V _{IH}	Input HIGH Voltage		2.7 – 3.6	1.6 – 3.6	2.0	–	V
			2.3 – 2.7		1.6	–	
			1.4 – 2.3		0.65 * V _{CCA}	–	
V _{IL}	Input LOW Voltage		2.7 – 3.6	1.6 – 3.6	–	0.8	V
			2.3 – 2.7		–	0.7	
			1.6 – 2.3		–	0.35 * V _{CCA}	
V _{OH}	Output HIGH Voltage	I _{OH} = -100 μA; V _I = V _{IH}	1.6 – 3.6	1.6 – 3.6	V _{CCB} - 0.2	–	V
		I _{OH} = -6 mA; V _I = V _{IH}	1.6	1.6	1.25	–	
			2.3	2.3	2.0	–	
		I _{OH} = -12 mA; V _I = V _{IH}	2.3	2.3	1.8	–	
			2.7	2.7	2.2	–	
		I _{OH} = -18 mA; V _I = V _{IH}	2.3	2.3	1.7	–	
3.0	3.0		2.4	–			
V _{OL}	Output LOW Voltage	I _{OL} = 100 μA; V _I = V _{IL}	1.6 – 3.6	1.6 – 3.6	–	0.2	V
		I _{OL} = 6 mA; V _I = V _{IL}	1.6	1.6	–	0.3	
			2.3	2.3	–	0.4	
		I _{OL} = 12 mA; V _I = V _{IL}	2.7	2.7	–	0.4	
			2.3	2.3	–	0.6	
		I _{OL} = 24 mA; V _I = V _{IL}	3.0	3.0	–	0.5	
I _{OL} = 24 mA; V _I = V _{IL}	3.0	3.0	–	0.6			
I _I	Input Leakage Current	V _I = V _{CCA} or GND	1.6 – 3.6	1.6 – 3.6	-1.0	+1.0	μA
I _{OZ}	I/O Tri-State Output Leakage Current	T _A = 25°C, OE = GND	1.6 – 3.6	1.6 – 3.6	–	2.0	μA
I _{CCA}	Quiescent Supply Current	V _I = V _{CCA} or GND; I _O = 0	1.6 – 3.6	1.6 – 3.6	–	2.0	μA
I _{CCB}	Quiescent Supply Current	V _I = V _{CCA} or GND; I _O = 0	1.6 – 3.6	1.6 – 3.6	–	2.0	μA
I _{CCA} + I _{CCB}	Quiescent Supply Current	V _I = V _{CCA} or GND; I _O = 0	1.6 – 3.6	1.6 – 3.6	–	4.0	μA

TOTAL STATIC POWER CONSUMPTION (I_{CCA} + I_{CCB})

V _{CCA} (V)	-40°C to +85°C						Unit
	V _{CCB} (V)						
	3.6		2.8		1.6		
	Min	Max	Min	Max	Min	Max	
3.6		2		2		2	μA
2.8		< 1		< 1		< 0.5	μA
1.6		< 1		< 1		< 0.5	μA

NOTE: Connect ground before applying supply voltage V_{CCA} or V_{CCB}. This device is designed with the feature that the power-up sequence of V_{CCA} and V_{CCB} will not damage the IC.

NLSV22T244

AC ELECTRICAL CHARACTERISTICS

Symbol	Parameter	V _{CCA} (V)	-40°C to +85°C						Unit
			V _{CCB} (V)						
			3.6		2.8		1.6		
			Min	Max	Min	Max	Min	Max	
t _{PLH} , t _{PHL}	Propagation Delay, A _n to B _n	3.6		3.4		3.6		3.8	nS
		2.8		3.6		3.8		4.0	
		1.6		3.9		4.0		4.5	
t _{PZH} , t _{PZL}	Output Enable, OE to OUT_X _n	3.6		5.8		6.0		6.2	nS
		2.8		6.0		6.2		6.4	
		1.6		8.2		8.4		8.6	
t _{PHZ} , t _{PLZ}	Output Disable, OE to OUT_X _n	3.6		5.8		6.0		6.2	nS
		2.8		6.0		6.2		6.4	
		1.6		8.2		8.4		8.6	
t _{OSHL} , t _{OSLH}	Output-to-Output Skew, Data-to-Output	3.6		0.15		0.15		0.15	nS
		2.8		0.15		0.15		0.15	
		1.6		0.15		0.15		0.15	

1. Propagation delays defined per Figure 3.

CAPACITANCE

Symbol	Parameter	Test Conditions	Typ (Note 2)	Unit
C _{IN}	Control Pin Input Capacitance	V _{CCA} = V _{CCB} = 3.3 V, V _I = 0 V or V _{CCA/B}	3.5	pF
C _{I/O}	I/O Pin Input Capacitance	V _{CCA} = V _{CCB} = 3.3 V, V _I = 0 V or V _{CCA/B}	5.0	pF
C _{PD}	Power Dissipation Capacitance	V _{CCA} = V _{CCB} = 3.3 V, V _I = 0 V or V _{CCA} , f = 10 MHz	10	pF

2. Typical values are at T_A = +25°C.

3. C_{PD} is defined as the value of the IC's equivalent capacitance from which the operating current can be calculated from:
 $I_{CC(operating)} \cong C_{PD} \times V_{CC} \times f_{IN} \times N_{SW}$ where I_{CC} = I_{CCA} + I_{CCB} and N_{SW} = total number of outputs switching.

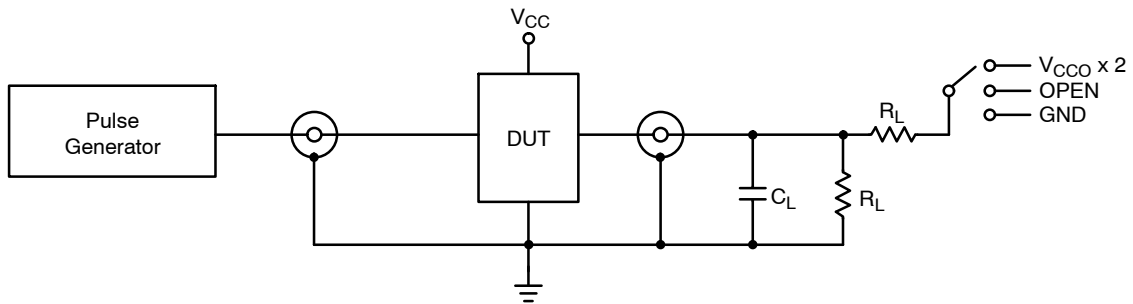
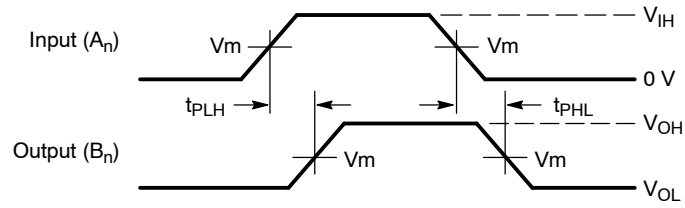

Figure 3. AC (Propagation Delay) Test Circuit

Test	Switch
t _{PLH} , t _{PHL}	OPEN
t _{PLZ} , t _{PZL}	V _{CCO} x 2 at V _{CCB} = 3.0 V – 3.6 mV, 2.3 V – 2.7 V, 1.6 V – 1.95 V
t _{PHZ} , t _{PZH}	GND

C_L = 15 pF or equivalent (includes probe and jig capacitance)
R_L = 2 kΩ or equivalent
Z_{OUT} of pulse generator = 50 Ω

NLSV22T244



Waveform 1 - Propagation Delays

$t_R = t_F = 2.0 \text{ ns}$, 10% to 90%; $f = 1 \text{ MHz}$; $t_W = 500 \text{ ns}$

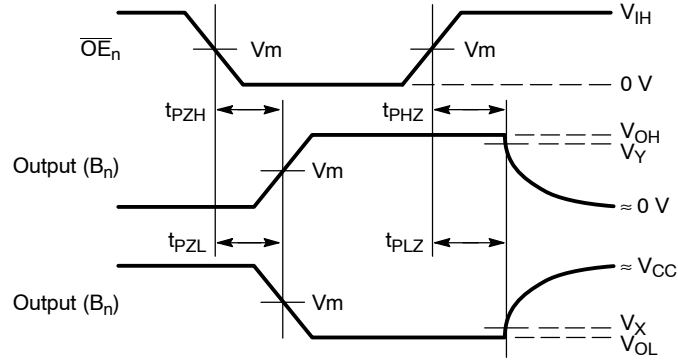

Waveform 2 - Output Enable and Disable Times

$t_R = t_F = 2.0 \text{ ns}$, 10% to 90%; $f = 1 \text{ MHz}$; $t_W = 500 \text{ ns}$

Figure 4. AC (Propagation Delay) Test Circuit Waveforms

Symbol	V _{CC}
	3.0 V – 3.6 V
V _{mA}	V _{CCA} /2
V _{mB}	V _{CCB} /2
V _X	V _{OL} × 0.1
V _Y	V _{OH} × 0.9

NLSV22T244

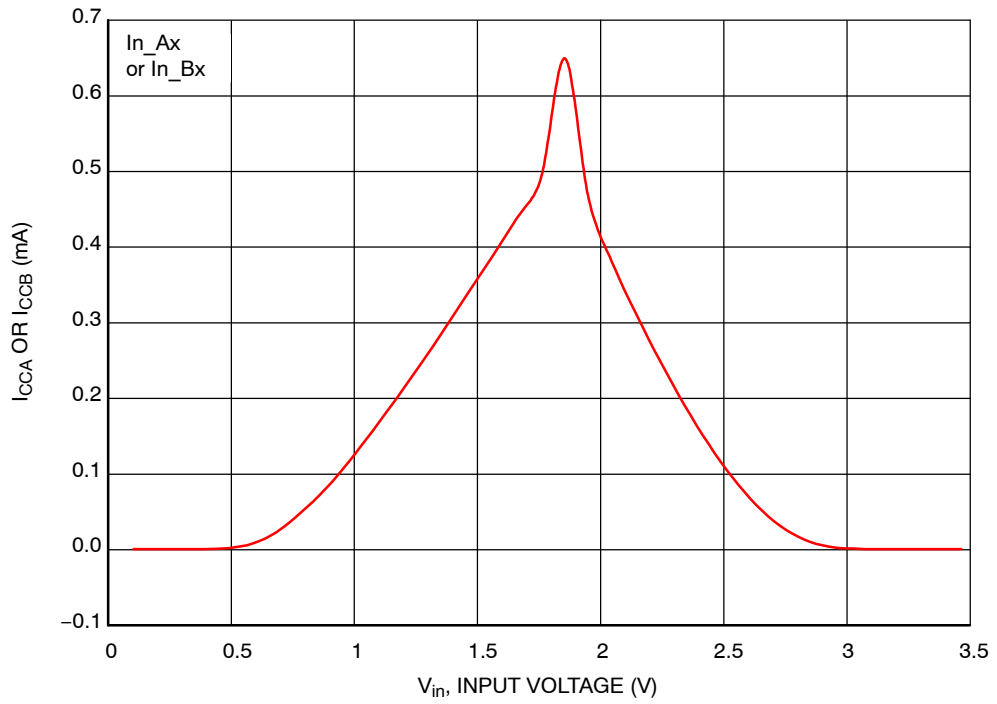
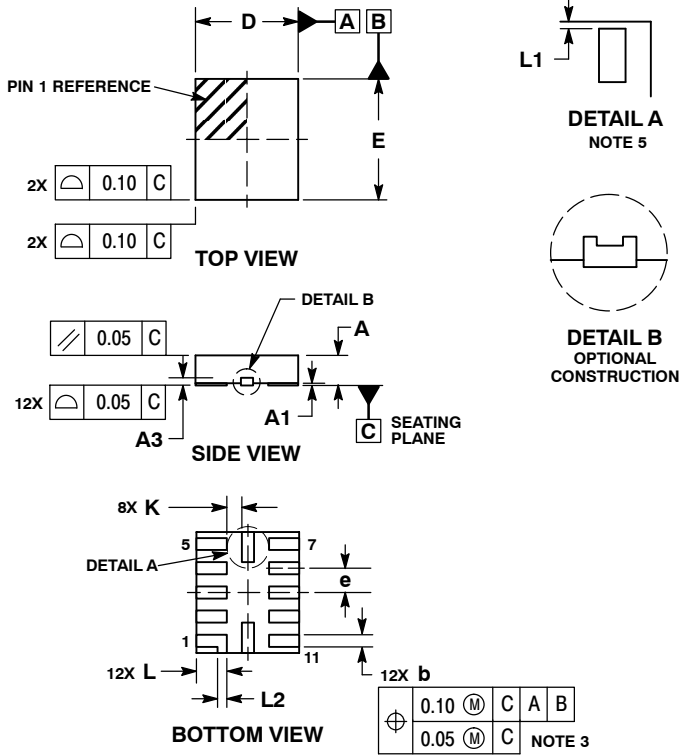

Figure 5. Delta I_{CC}
Increase in I_{CC} per Input Voltage, Other Inputs at V_{CCA} / V_{CCB} or GND

NLSV22T244

PACKAGE DIMENSIONS

UQFN12 1.7x2.0, 0.4P
CASE 523AE-01
ISSUE A



NOTES:

1. DIMENSIONING AND TOLERANCING PER ASME Y14.5M, 1994.
2. CONTROLLING DIMENSION: MILLIMETERS
3. DIMENSION b APPLIES TO PLATED TERMINAL AND IS MEASURED BETWEEN 0.15 AND 0.30 MM FROM TERMINAL TIP.
4. MOLD FLASH ALLOWED ON TERMINALS ALONG EDGE OF PACKAGE. FLASH 0.03 MAX ON BOTTOM SURFACE OF TERMINALS.
5. DETAIL A SHOWS OPTIONAL CONSTRUCTION FOR TERMINALS.

DIM	MILLIMETERS	
	MIN	MAX
A	0.45	0.55
A1	0.00	0.05
A3	0.127 REF	
b	0.15	0.25
D	1.70 BSC	
E	2.00 BSC	
e	0.40 BSC	
K	0.20	----
L	0.45	0.55
L1	0.00	0.03
L2	0.15 REF	

**MOUNTING FOOTPRINT
SOLDERMASK DEFINED**

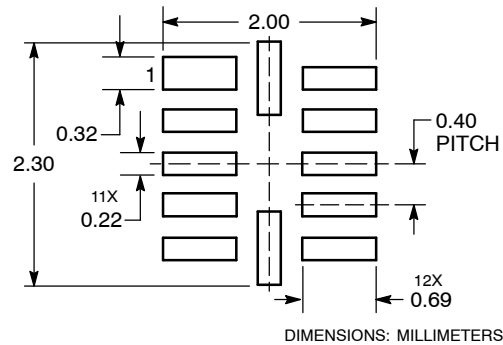

*For additional information on our Pb-Free strategy and soldering details, please download the ON Semiconductor Soldering and Mounting Techniques Reference Manual, SOLDERRM/D.

ON Semiconductor and are registered trademarks of Semiconductor Components Industries, LLC (SCILLC). SCILLC reserves the right to make changes without further notice to any products herein. SCILLC makes no warranty, representation or guarantee regarding the suitability of its products for any particular purpose, nor does SCILLC assume any liability arising out of the application or use of any product or circuit, and specifically disclaims any and all liability, including without limitation special, consequential or incidental damages. "Typical" parameters which may be provided in SCILLC data sheets and/or specifications can and do vary in different applications and actual performance may vary over time. All operating parameters, including "Typicals" must be validated for each customer application by customer's technical experts. SCILLC does not convey any license under its patent rights nor the rights of others. SCILLC products are not designed, intended, or authorized for use as components in systems intended for surgical implant into the body, or other applications intended to support or sustain life, or for any other application in which the failure of the SCILLC product could create a situation where personal injury or death may occur. Should Buyer purchase or use SCILLC products for any such unintended or unauthorized application, Buyer shall indemnify and hold SCILLC and its officers, employees, subsidiaries, affiliates, and distributors harmless against all claims, costs, damages, and expenses, and reasonable attorney fees arising out of, directly or indirectly, any claim of personal injury or death associated with such unintended or unauthorized use, even if such claim alleges that SCILLC was negligent regarding the design or manufacture of the part. SCILLC is an Equal Opportunity/Affirmative Action Employer. This literature is subject to all applicable copyright laws and is not for resale in any manner.

PUBLICATION ORDERING INFORMATION

LITERATURE FULFILLMENT:
Literature Distribution Center for ON Semiconductor
P.O. Box 5163, Denver, Colorado 80217 USA
Phone: 303-675-2175 or 800-344-3860 Toll Free USA/Canada
Fax: 303-675-2176 or 800-344-3867 Toll Free USA/Canada
Email: orderlit@onsemi.com

N. American Technical Support: 800-282-9855 Toll Free USA/Canada
Europe, Middle East and Africa Technical Support:
Phone: 421 33 790 2910
Japan Customer Focus Center
Phone: 81-3-5773-3850

ON Semiconductor Website: www.onsemi.com
Order Literature: <http://www.onsemi.com/orderlit>
For additional information, please contact your local Sales Representative

X-ON Electronics

Largest Supplier of Electrical and Electronic Components

Click to view similar products for [Translation - Voltage Levels](#) category:

Click to view products by [ON Semiconductor](#) manufacturer:

Other Similar products are found below :

[NLSX4373DMR2G](#) [NLSX5012MUTAG](#) [NLSX0102FCT2G](#) [NLSX4302EBMUTCG](#) [PCA9306FMUTAG](#) [MC100EPT622MNG](#)
[NLSX5011MUTCG](#) [NLV9306USG](#) [NLVSX4014MUTAG](#) [NLSV4T3144MUTAG](#) [NLVSX4373MUTAG](#) [NB3U23CMNTAG](#)
[MAX3371ELT+T](#) [NLSX3013BFCT1G](#) [NLV7WBD3125USG](#) [NLSX3012DMR2G](#) [74AVCH1T45FZ4-7](#) [NLVSV1T244MUTBG](#)
[74AVC1T45GS-Q100H](#) [CLVC16T245MDGGREP](#) [MC10H124FNG](#) [CAVCB164245MDGGREP](#) [CD40109BPWR](#) [MC10H350FNG](#)
[MC10H125FNG](#) [MC100EPT21MNR4G](#) [MC100EP91DWG](#) [NLSX3018MUTAG](#) [NLSV2T244MUTAG](#) [NLSX3013FCT1G](#)
[NLSX5011AMX1TCG](#) [PCA9306USG](#) [SN74GTL1655DGGR](#) [SN74AVCA406LZQSR](#) [NLSX4014DTR2G](#) [NLSX3018DTR2G](#)
[LTC1045CSW#PBF](#) [LTC1045CN#PBF](#) [SY100EL92ZG](#) [74AXP1T34GMH](#) [74AXP1T34GNH](#) [LSF0204DPWR](#) [PI4ULS3V204LE](#)
[ADG3245BRUZ-REEL7](#) [ADG3123BRUZ](#) [ADG3245BRUZ](#) [ADG3246BCPZ](#) [ADG3308BCPZ-REEL](#) [ADG3233BRJZ-REEL7](#)
[ADG3233BRMZ](#)