

# NLSX4378

## 4-Bit 24 Mb/s Dual-Supply Level Translator

The NLSX4378 is a 4-bit configurable dual-supply bidirectional auto sensing translator that does not require a directional control pin. The  $V_{CC}$  I/O and  $V_L$  I/O ports are designed to track two different power supply rails,  $V_{CC}$  and  $V_L$  respectively. The  $V_{CC}$  supply rail is configurable from 1.65 V to 5.5 V while  $V_L$  supply rail is configurable to 1.65 V to 5.5 V. This allows voltage logic signals on the  $V_L$  side to be translated into lower, higher or equal value voltage logic signals on the  $V_{CC}$  side, and vice-versa.

The NLSX4378 translator has open-drain outputs with integrated 10 k $\Omega$  pullup resistors on the I/O lines. The integrated pullup resistors are used to pullup the I/O lines to either  $V_L$  or  $V_{CC}$ . The NLSX4378 is an excellent match for open-drain applications such as the I<sup>2</sup>C communication bus.

### Features

- $V_L$  can be Less than, Greater than or Equal to  $V_{CC}$
- Wide  $V_{CC}$  Operating Range: 1.65 V to 5.5 V  
Wide  $V_L$  Operating Range: 1.65 V to 5.5 V
- High-Speed with 24 Mb/s Guaranteed Data Rate
- Low Bit-to-Bit Skew
- Enable Input and I/O Lines have Overvoltage Tolerant (OVT) to 5.5 V
- Nonpreferential Powerup Sequencing
- Integrated 10 k $\Omega$  Pullup Resistors
- Small Space Saving Package – 2.02 x 1.54 mm  $\mu$ Bump12
- This is a Pb-Free Device

### Typical Applications

- I<sup>2</sup>C, SMBus, PMBus
- Low Voltage ASIC Level Translation
- Mobile Phones, PDAs, Cameras



ON Semiconductor®

<http://onsemi.com>



$\mu$ Bump12  
FC SUFFIX  
CASE 499AU

### MARKING DIAGRAM

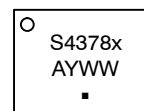

- x = F – Standard  
B – Backcoated
- A = Assembly Location
- Y = Year
- WW = Work Week
- = Pb-Free Package

### LOGIC DIAGRAM

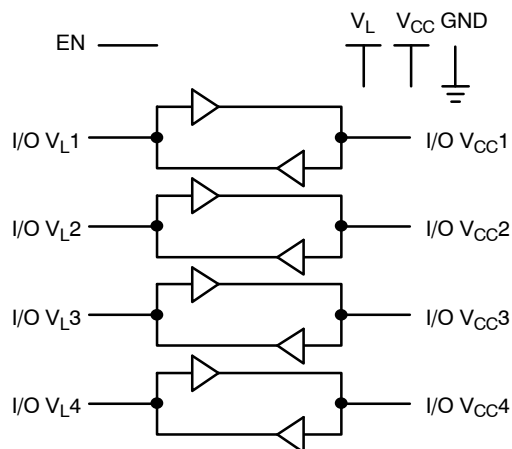

### ORDERING INFORMATION

See detailed ordering and shipping information in the package dimensions section on page 8 of this data sheet.

# NLSX4378

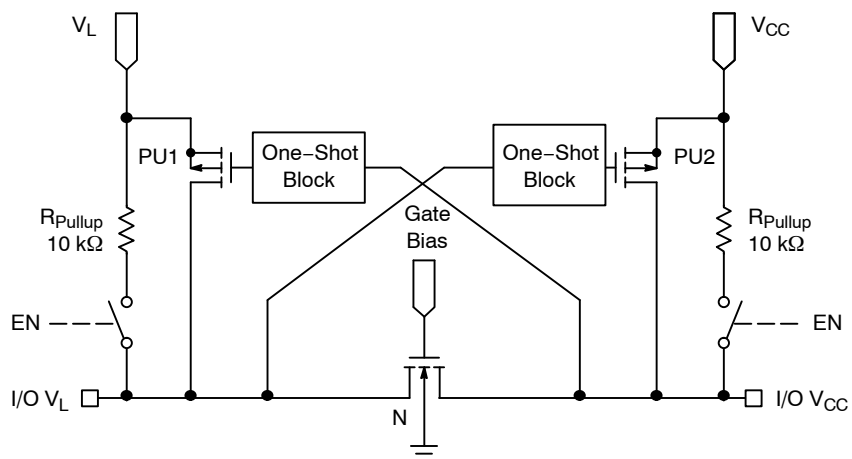

Figure 1. Block Diagram (1 I/O Line)

## PIN ASSIGNMENT

Pins	Description
V <sub>CC</sub>	V <sub>CC</sub> Input Voltage
V <sub>L</sub>	V <sub>L</sub> Input Voltage
GND	Ground
EN	Output Enable
I/O V <sub>CCn</sub>	V <sub>CC</sub> I/O Port, Referenced to V <sub>CC</sub>
I/O V <sub>Ln</sub>	V <sub>L</sub> I/O Port, Referenced to V <sub>L</sub>

## FUNCTION TABLE

EN	Operating Mode
L	Hi-Z
H	I/O Buses Connected

## PIN LOCATION

Pin	Pin Name
A1	I/O V <sub>L</sub> 1
A2	I/O V <sub>L</sub> 2
A3	I/O V <sub>L</sub> 3
A4	I/O V <sub>L</sub> 4
B1	V <sub>CC</sub>
B2	V <sub>L</sub>
B3	EN
B4	GND
C1	I/O V <sub>CC</sub> 1
C2	I/O V <sub>CC</sub> 2
C3	I/O V <sub>CC</sub> 3
C4	I/O V <sub>CC</sub> 4

## μBump12

(2.02 x 1.54 mm)

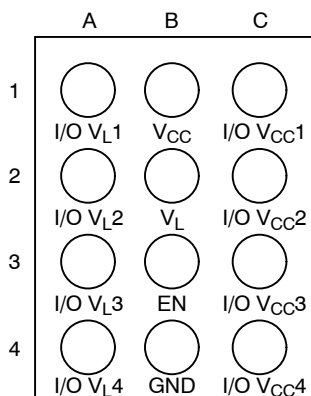

(Bottom View)

# NLSX4378

## MAXIMUM RATINGS

Symbol	Parameter	Condition	Value	Unit
V <sub>CC</sub>	DC Supply Voltage		-0.3 to +7.0	V
V <sub>L</sub>	DC Supply Voltage		-0.3 to +7.0	V
I/O V <sub>CC</sub>	V <sub>CC</sub> -Referenced DC Input/Output Voltage		-0.3 to (V <sub>CC</sub> + 0.3)	V
I/O V <sub>L</sub>	V <sub>L</sub> -Referenced DC Input/Output Voltage		-0.3 to (V <sub>L</sub> + 0.3)	V
V <sub>EN</sub>	Enable Control Pin DC Input Voltage		-0.3 to +7.0	V
I <sub>I/O_SC</sub>	Short-Circuit Duration (I/O V <sub>L</sub> and I/O V <sub>CC</sub> to GND)	Continuous	40	mA
T <sub>STG</sub>	Storage Temperature		-65 to +150	°C

Stresses exceeding Maximum Ratings may damage the device. Maximum Ratings are stress ratings only. Functional operation above the Recommended Operating Conditions is not implied. Extended exposure to stresses above the Recommended Operating Conditions may affect device reliability.

## RECOMMENDED OPERATING CONDITIONS

Symbol	Parameter	Min	Max	Unit
V <sub>CC</sub>	DC Supply Voltage	1.65	5.5	V
V <sub>L</sub>	DC Supply Voltage	1.65	5.5	V
V <sub>EN</sub>	Enable Control Pin Voltage	GND	5.5	V
V <sub>IO</sub>	Enable Control Pin Voltage	GND	5.5	V
T <sub>A</sub>	Operating Temperature Range	-40	+85	°C

## DC ELECTRICAL CHARACTERISTICS (V<sub>CC</sub> = 1.65 V to 5.5 V and V<sub>L</sub> = 1.65 V to 5.5 V, unless otherwise specified)

Symbol	Parameter	Test Conditions	-40°C to +85°C			Unit
			Min	Typ (Notes 1, 2)	Max	
V <sub>IHC</sub>	I/O V <sub>CC</sub> Input HIGH Voltage		V <sub>CC</sub> - 0.4	-	-	V
V <sub>ILC</sub>	I/O V <sub>CC</sub> Input LOW Voltage		-	-	0.15	V
V <sub>IHL</sub>	I/O V <sub>L</sub> Input HIGH Voltage		V <sub>L</sub> - 0.4	-	-	V
V <sub>ILL</sub>	I/O V <sub>L</sub> Input LOW Voltage		-	-	0.15	V
V <sub>IH</sub>	Control Pin Input HIGH Voltage		0.65 * V <sub>L</sub>	-	-	V
V <sub>IL</sub>	Control Pin Input LOW Voltage		-	-	0.35 * V <sub>L</sub>	V
V <sub>OHC</sub>	I/O V <sub>CC</sub> Output HIGH Voltage	I/O V <sub>CC</sub> Source Current = 20 μA	0.8 * V <sub>CC</sub>	-	-	V
V <sub>OLC</sub>	I/O V <sub>CC</sub> Output LOW Voltage	I/O V <sub>CC</sub> Sink Current = 1.0 mA I/O_V <sub>L</sub> ≤ 0.15 V	-	-	0.4	V
V <sub>OHL</sub>	I/O V <sub>L</sub> Output HIGH Voltage	I/O V <sub>L</sub> Source Current = 20 μA	0.8 * V <sub>L</sub>	-	-	V
V <sub>OLL</sub>	I/O V <sub>L</sub> Output LOW Voltage	I/O V <sub>L</sub> Sink Current = 1.0 mA I/O_V <sub>CC</sub> ≤ 0.15 V	-	-	0.4	V
I <sub>QVCC</sub>	V <sub>CC</sub> Supply Current	I/O V <sub>CC</sub> and I/O V <sub>L</sub> Unconnected, V <sub>EN</sub> = V <sub>L</sub>	-	0.5	2.0	μA
I <sub>QVL</sub>	V <sub>L</sub> Supply Current	I/O V <sub>CC</sub> and I/O V <sub>L</sub> Unconnected, V <sub>EN</sub> = V <sub>L</sub>	-	0.3	1.0	μA
I <sub>TS-VCC</sub>	V <sub>CC</sub> Tristate Output Mode Supply Current	I/O V <sub>CC</sub> and I/O V <sub>L</sub> Unconnected, V <sub>EN</sub> = GND	-	0.1	1.0	μA
I <sub>TS-VL</sub>	V <sub>L</sub> Tristate Output Mode Supply Current	I/O V <sub>CC</sub> and I/O V <sub>L</sub> Unconnected, V <sub>EN</sub> = GND	-	0.1	1.0	μA
I <sub>OZ</sub>	I/O Tristate Output Mode Leakage Current	T <sub>A</sub> = +25°C	-	0.1	1.0	μA
R <sub>PU</sub>	Pullup Resistor I/O V <sub>L</sub> and V <sub>CC</sub>	T <sub>A</sub> = +25°C	-	10	-	kΩ

1. Typical values are for V<sub>CC</sub> = +2.8 V, V<sub>L</sub> = +1.8 V and T<sub>A</sub> = +25°C.
2. All units are production tested at T<sub>A</sub> = +25°C. Limits over the operating temperature range are guaranteed by design.

# NLSX4378

## TIMING CHARACTERISTICS – RAIL-TO-RAIL DRIVING CONFIGURATIONS

(I/O test circuit of Figures 2 and 3,  $C_{LOAD} = 15 \text{ pF}$ , driver output impedance  $\leq 50 \Omega$ ,  $R_{LOAD} = 1 \text{ M}\Omega$ )

Symbol	Parameter	Test Conditions	-40°C to +85°C (Note 3)			Unit
			Min	Typ	Max	

**$V_L = 1.65 \text{ V}$ ,  $V_{CC} = 5.5 \text{ V}$**

$t_{RVCC}$	I/O $V_{CC}$ Risetime				15	ns
$t_{FVCC}$	I/O $V_{CC}$ Falltime				20	ns
$t_{RVL}$	I/O $V_L$ Risetime				30	ns
$t_{FVL}$	I/O $V_L$ Falltime				10	ns
$t_{PDVL-VCC}$	Propagation Delay (Driving I/O $V_L$ )				20	ns
$t_{PDVCC-VL}$	Propagation Delay (Driving I/O $V_{CC}$ )				20	ns
$t_{PPSKEW}$	Part-to-Part Skew				5	nS
MDR	Maximum Data Rate		24			Mb/s

**$V_L = 1.8 \text{ V}$ ,  $V_{CC} = 2.8 \text{ V}$**

$t_{RVCC}$	I/O $V_{CC}$ Risetime				15	ns
$t_{FVCC}$	I/O $V_{CC}$ Falltime				15	ns
$t_{RVL}$	I/O $V_L$ Risetime				25	ns
$t_{FVL}$	I/O $V_L$ Falltime				10	ns
$t_{PDVL-VCC}$	Propagation Delay (Driving I/O $V_L$ )				15	ns
$t_{PDVCC-VL}$	Propagation Delay (Driving I/O $V_{CC}$ )				15	ns
$t_{PPSKEW}$	Part-to-Part Skew				5	nS
MDR	Maximum Data Rate		24			Mb/s

**$V_L = 2.5 \text{ V}$ ,  $V_{CC} = 3.6 \text{ V}$**

$t_{RVCC}$	I/O $V_{CC}$ Risetime				15	ns
$t_{FVCC}$	I/O $V_{CC}$ Falltime				10	ns
$t_{RVL}$	I/O $V_L$ Risetime				15	ns
$t_{FVL}$	I/O $V_L$ Falltime				10	ns
$t_{PDVL-VCC}$	Propagation Delay (Driving I/O $V_L$ )				15	ns
$t_{PDVCC-VL}$	Propagation Delay (Driving I/O $V_{CC}$ )				15	ns
$t_{PPSKEW}$	Part-to-Part Skew				5	nS
MDR	Maximum Data Rate		24			Mb/s

**$V_L = 2.8 \text{ V}$ ,  $V_{CC} = 1.8 \text{ V}$**

$t_{RVCC}$	I/O $V_{CC}$ Risetime				25	ns
$t_{FVCC}$	I/O $V_{CC}$ Falltime				10	ns
$t_{RVL}$	I/O $V_L$ Risetime				20	ns
$t_{FVL}$	I/O $V_L$ Falltime				15	ns
$t_{PDVL-VCC}$	Propagation Delay (Driving I/O $V_L$ )				15	ns
$t_{PDVCC-VL}$	Propagation Delay (Driving I/O $V_{CC}$ )				15	ns
$t_{PPSKEW}$	Part-to-Part Skew				5	nS
MDR	Maximum Data Rate		24			Mb/s

3. All units are production tested at  $T_A = +25^\circ\text{C}$ . Limits over the operating temperature range are guaranteed by design.

# NLSX4378

## TIMING CHARACTERISTICS – RAIL-TO-RAIL DRIVING CONFIGURATIONS

(I/O test circuit of Figures 2 and 3,  $C_{LOAD} = 15 \text{ pF}$ , driver output impedance  $\leq 50 \Omega$ ,  $R_{LOAD} = 1 \text{ M}\Omega$ )

Symbol	Parameter	Test Conditions	-40°C to +85°C (Note 3)			Unit
			Min	Typ	Max	
<b><math>V_L = 3.6 \text{ V}</math>, <math>V_{CC} = 2.5 \text{ V}</math></b>						
$t_{RVCC}$	I/O $V_{CC}$ Risetime				15	ns
$t_{FVCC}$	I/O $V_{CC}$ Falltime				10	ns
$t_{RVL}$	I/O $V_L$ Risetime				15	ns
$t_{FVL}$	I/O $V_L$ Falltime				15	ns
$t_{PDVL-VCC}$	Propagation Delay (Driving I/O $V_L$ )				15	ns
$t_{PDVCC-VL}$	Propagation Delay (Driving I/O $V_{CC}$ )				15	ns
$t_{PPSKEW}$	Part-to-Part Skew				5	nS
MDR	Maximum Data Rate		24			Mb/s

**$V_L = 5.5 \text{ V}$ ,  $V_{CC} = 1.65 \text{ V}$**

$t_{RVCC}$	I/O $V_{CC}$ Risetime				30	ns
$t_{FVCC}$	I/O $V_{CC}$ Falltime				10	ns
$t_{RVL}$	I/O $V_L$ Risetime				15	ns
$t_{FVL}$	I/O $V_L$ Falltime				20	ns
$t_{PDVL-VCC}$	Propagation Delay (Driving I/O $V_L$ )				20	ns
$t_{PDVCC-VL}$	Propagation Delay (Driving I/O $V_{CC}$ )				20	ns
$t_{PPSKEW}$	Part-to-Part Skew				5	nS
MDR	Maximum Data Rate		24			Mb/s

3. All units are production tested at  $T_A = +25^\circ\text{C}$ . Limits over the operating temperature range are guaranteed by design.

## TIMING CHARACTERISTICS – OPEN DRAIN DRIVING CONFIGURATIONS

(I/O test circuit of Figures 4 and 5,  $C_{LOAD} = 15 \text{ pF}$ , driver output impedance  $\leq 50 \Omega$ ,  $R_{LOAD} = 1 \text{ M}\Omega$ )

Symbol	Parameter	Test Conditions	-40°C to +85°C (Note 4)			Unit
			Min	Typ	Max	
<b><math>+1.65 \leq V_L</math>, <math>V_{CC} \leq +5.5 \text{ V}</math></b>						
$t_{RVCC}$	I/O $V_{CC}$ Risetime				400	ns
$t_{FVCC}$	I/O $V_{CC}$ Falltime				50	ns
$t_{RVL}$	I/O $V_L$ Risetime				400	ns
$t_{FVL}$	I/O $V_L$ Falltime				60	ns
$t_{PDVL-VCC}$	Propagation Delay (Driving I/O $V_L$ )				1000	ns
$t_{PDVCC-VL}$	Propagation Delay (Driving I/O $V_{CC}$ )				1000	ns
$t_{PPSKEW}$	Part-to-Part Skew				50	nS
MDR	Maximum Data Rate		2			Mb/s

4. All units are production tested at  $T_A = +25^\circ\text{C}$ . Limits over the operating temperature range are guaranteed by design. Limits over the operating temperature range are guaranteed by design.

# NLSX4378

## TEST SETUPS

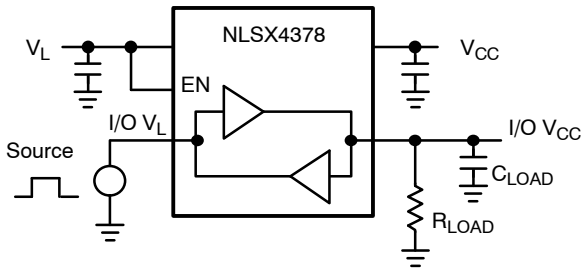

Figure 2. Rail-to-Rail Driving I/O  $V_L$

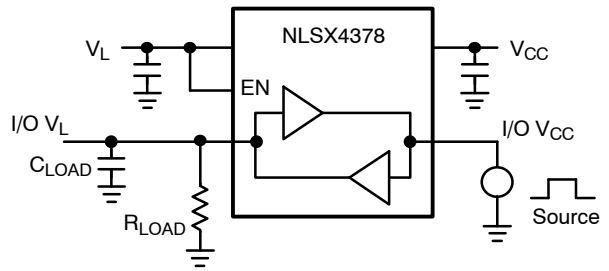

Figure 3. Rail-to-Rail Driving I/O  $V_{CC}$

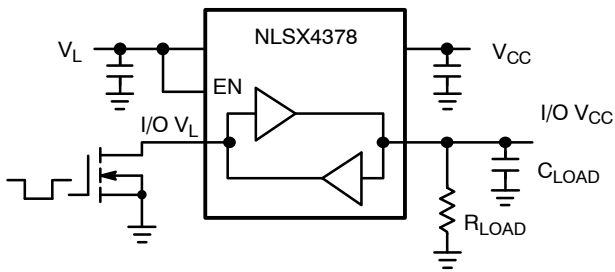

Figure 4. Open-Drain Driving I/O  $V_L$

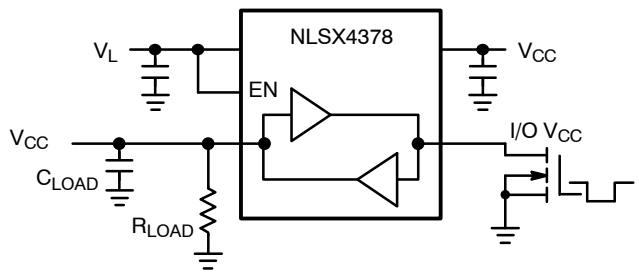

Figure 5. Open-Drain Driving I/O  $V_{CC}$

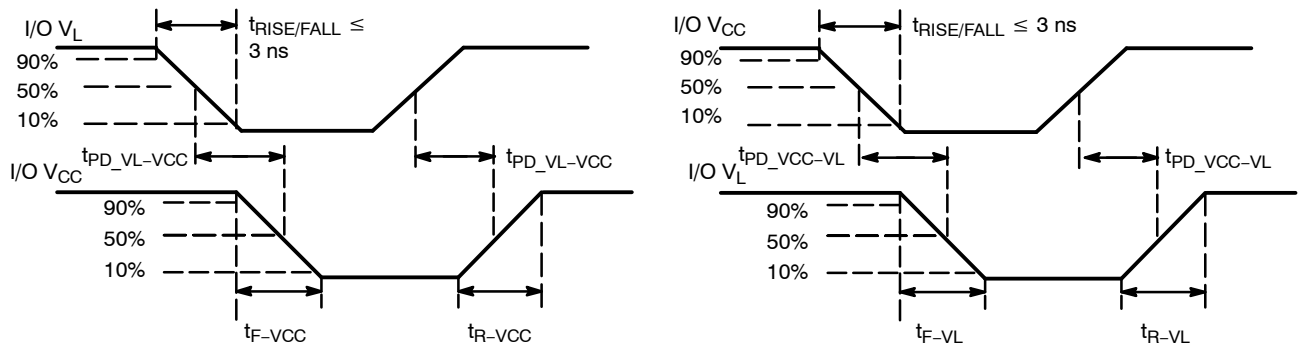
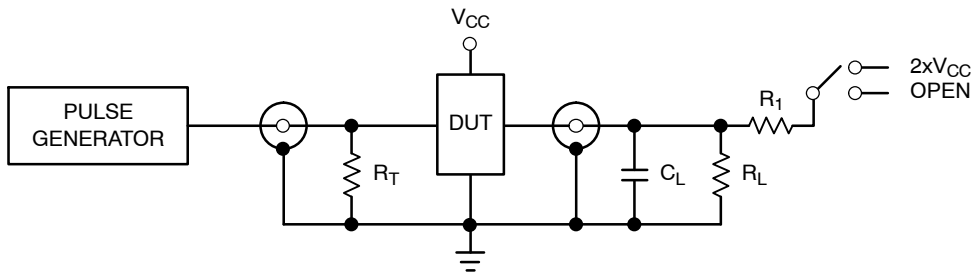

Figure 6. Definition of Timing Specification Parameters

# NLSX4378



Test	Switch
$t_{PZH}$ , $t_{PHZ}$	Open
$t_{PZL}$ , $t_{PLZ}$	$2 \times V_{CC}$

$C_L = 15 \text{ pF}$  or equivalent (Includes jig and probe capacitance)  
 $R_L = R_1 = 50 \text{ k}\Omega$  or equivalent  
 $R_T = Z_{OUT}$  of pulse generator (typically  $50 \Omega$ )

**Figure 7. Test Circuit for Enable/Disable Time Measurement**

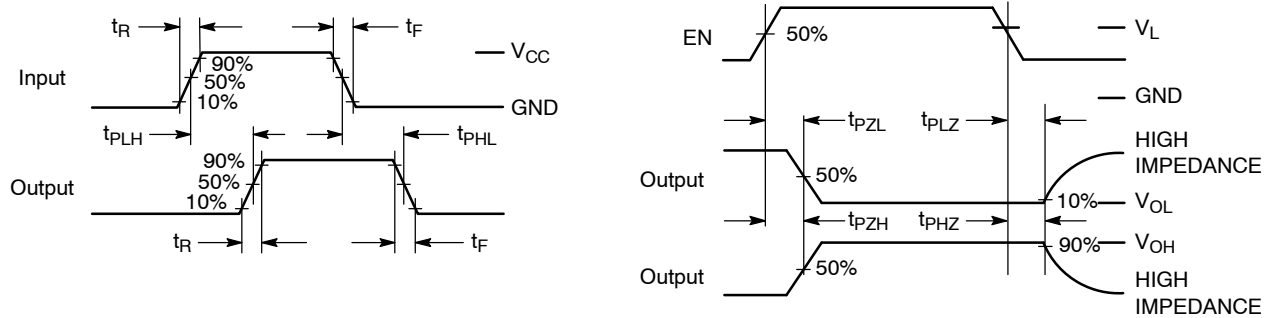

**Figure 8. Timing Definitions for Propagation Delays and Enable/Disable Measurement**

## APPLICATIONS INFORMATION

### Level Translator Architecture

The NLSX4378 auto sense translator provides bi-directional voltage level shifting to transfer data in multiple supply voltage systems. This device has two supply voltages,  $V_L$  and  $V_{CC}$ , which set the logic levels on the input and output sides of the translator. When used to transfer data from the  $V_L$  to the  $V_{CC}$  ports, input signals referenced to the  $V_L$  supply are translated to output signals with a logic level matched to  $V_{CC}$ . In a similar manner, the  $V_{CC}$  to  $V_L$  translation shifts input signals with a logic level compatible to  $V_{CC}$  to an output signal matched to  $V_L$ .

The NLSX4378 consists of two bi-directional channels that independently determine the direction of the data flow without requiring a directional pin. The one-shot circuits are used to detect the rising input signals. In addition, the one shots decrease the rise time of the output signal for low-to-high transitions.

Each input/output channel has an internal 10 k $\Omega$  pull. The magnitude of the pullup resistors can be reduced by connecting external resistors in parallel to the internal 10 k $\Omega$  resistors.

### Input Driver Requirements

The rise ( $t_R$ ) and fall ( $t_F$ ) timing parameters of the open drain outputs depend on the magnitude of the pull-up resistors. In addition, the propagation times ( $t_{PD}$ ), skew ( $t_{PSKEW}$ ) and maximum data rate depend on the impedance of the device that is connected to the translator. The timing

parameters listed in the data sheet assume that the output impedance of the drivers connected to the translator is less than 50  $\Omega$ .

### Enable Input (EN)

The NLSX4378 has an Enable pin (EN) that provides tri-state operation at the I/O pins. Driving the Enable pin to a low logic level minimizes the power consumption of the device and drives the I/O  $V_{CC}$  and I/O  $V_L$  pins to a high impedance state. Normal translation operation occurs when the EN pin is equal to a logic high signal. The EN pin is referenced to the  $V_L$  supply and has Overvoltage Tolerant (OVT) protection.

### Power Supply Guidelines

During normal operation, supply voltage  $V_L$  can be greater than, less than or equal to  $V_{CC}$ . The sequencing of the power supplies will not damage the device during the power up operation.

For optimal performance, 0.01  $\mu$ F to 0.1  $\mu$ F decoupling capacitors should be used on the  $V_L$  and  $V_{CC}$  power supply pins. Ceramic capacitors are a good design choice to filter and bypass any noise signals on the voltage lines to the ground plane of the PCB. The noise immunity will be maximized by placing the capacitors as close as possible to the supply and ground pins, along with minimizing the PCB connection traces.

## ORDERING INFORMATION

Device	Package	Shipping†
NLSX4378FCT1G	$\mu$ Bump12 (Pb-Free)	3000 / Tape & Reel
NLSX4378BFCT1G	$\mu$ Bump12 (Backside Laminate Coating) (Pb-Free)	3000 / Tape & Reel

†For information on tape and reel specifications, including part orientation and tape sizes, please refer to our Tape and Reel Packaging Specifications Brochure, BRD8011/D.



# NLSX4378

## PACKAGE DIMENSIONS

**μBump12, 2.02x1.54, 0.5P**  
**CASE 499AU**  
**ISSUE O**

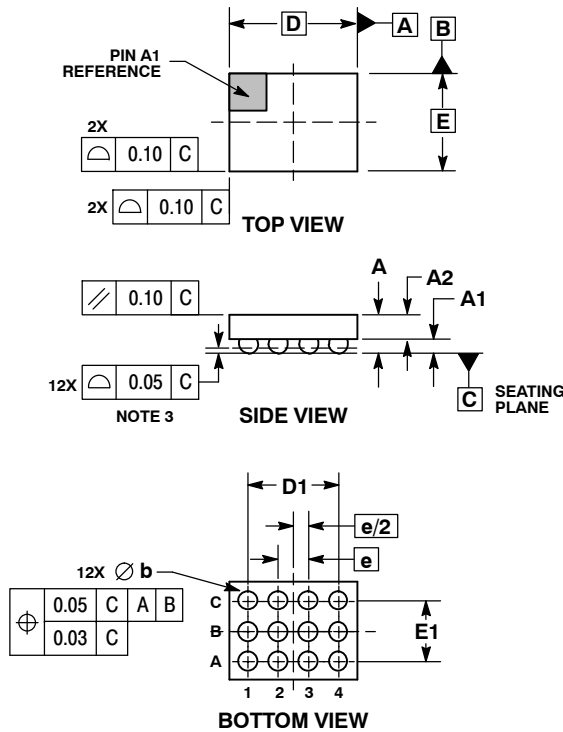

**NOTES:**

1. DIMENSIONING AND TOLERANCING PER ASME Y14.5M, 1994.
2. CONTROLLING DIMENSION: MILLIMETERS.
3. COPLANARITY APPLIES TO SPHERICAL CROWNS OF SOLDER BALLS.

DIM	MILLIMETERS	
	MIN	MAX
A	---	0.66
A1	0.21	0.27
A2	0.33	0.39
b	0.29	0.34
D	2.02 BSC	
D1	1.50 BSC	
E	1.54 BSC	
E1	1.00 BSC	
e	0.50 BSC	

**ON Semiconductor** and  are registered trademarks of Semiconductor Components Industries, LLC (SCILLC). SCILLC owns the rights to a number of patents, trademarks, copyrights, trade secrets, and other intellectual property. A listing of SCILLC's product/patent coverage may be accessed at [www.onsemi.com/site/pdf/Patent-Marking.pdf](http://www.onsemi.com/site/pdf/Patent-Marking.pdf). SCILLC reserves the right to make changes without further notice to any products herein. SCILLC makes no warranty, representation or guarantee regarding the suitability of its products for any particular purpose, nor does SCILLC assume any liability arising out of the application or use of any product or circuit, and specifically disclaims any and all liability, including without limitation special, consequential or incidental damages. "Typical" parameters which may be provided in SCILLC data sheets and/or specifications can and do vary in different applications and actual performance may vary over time. All operating parameters, including "Typicals" must be validated for each customer application by customer's technical experts. SCILLC does not convey any license under its patent rights nor the rights of others. SCILLC products are not designed, intended, or authorized for use as components in systems intended for surgical implant into the body, or other applications intended to support or sustain life, or for any other application in which the failure of the SCILLC product could create a situation where personal injury or death may occur. Should Buyer purchase or use SCILLC products for any such unintended or unauthorized application, Buyer shall indemnify and hold SCILLC and its officers, employees, subsidiaries, affiliates, and distributors harmless against all claims, costs, damages, and expenses, and reasonable attorney fees arising out of, directly or indirectly, any claim of personal injury or death associated with such unintended or unauthorized use, even if such claim alleges that SCILLC was negligent regarding the design or manufacture of the part. SCILLC is an Equal Opportunity/Affirmative Action Employer. This literature is subject to all applicable copyright laws and is not for resale in any manner.

### PUBLICATION ORDERING INFORMATION

**LITERATURE FULFILLMENT:**  
 Literature Distribution Center for ON Semiconductor  
 P.O. Box 5163, Denver, Colorado 80217 USA  
**Phone:** 303-675-2175 or 800-344-3860 Toll Free USA/Canada  
**Fax:** 303-675-2176 or 800-344-3867 Toll Free USA/Canada  
**Email:** [orderlit@onsemi.com](mailto:orderlit@onsemi.com)

**N. American Technical Support:** 800-282-9855 Toll Free  
 USA/Canada  
**Europe, Middle East and Africa Technical Support:**  
 Phone: 421 33 790 2910  
**Japan Customer Focus Center**  
 Phone: 81-3-5817-1050

**ON Semiconductor Website:** [www.onsemi.com](http://www.onsemi.com)  
**Order Literature:** <http://www.onsemi.com/orderlit>

For additional information, please contact your local Sales Representative

## X-ON Electronics

Largest Supplier of Electrical and Electronic Components

*Click to view similar products for [Translation - Voltage Levels](#) category:*

*Click to view products by [ON Semiconductor](#) manufacturer:*

Other Similar products are found below :

[NLSX4373DMR2G](#) [NLSX5012MUTAG](#) [NLSX0102FCT2G](#) [NLSX4302EBMUTCG](#) [PCA9306FMUTAG](#) [MC100EPT622MNG](#)  
[NLSX5011MUTCG](#) [NLV9306USG](#) [NLVSX4014MUTAG](#) [NLSV4T3144MUTAG](#) [NLVSX4373MUTAG](#) [NB3U23CMNTAG](#)  
[MAX3371ELT+T](#) [NLSX3013BFCT1G](#) [NLV7WBD3125USG](#) [NLSX3012DMR2G](#) [74AVCH1T45FZ4-7](#) [NLVSV1T244MUTBG](#)  
[74AVC1T45GS-Q100H](#) [CLVC16T245MDGGREP](#) [MC10H124FNG](#) [CAVCB164245MDGGREP](#) [CD40109BPWR](#) [MC10H350FNG](#)  
[MC10H125FNG](#) [MC100EPT21MNR4G](#) [MC100EP91DWG](#) [NLSX3018MUTAG](#) [NLSV2T244MUTAG](#) [NLSX3013FCT1G](#)  
[NLSX5011AMX1TCG](#) [PCA9306USG](#) [SN74GTL1655DGGR](#) [SN74AVCA406LZQSR](#) [NLSX4014DTR2G](#) [NLSX3018DTR2G](#)  
[LTC1045CSW#PBF](#) [LTC1045CN#PBF](#) [SY100EL92ZG](#) [74AXP1T34GMH](#) [74AXP1T34GNH](#) [LSF0204DPWR](#) [PI4ULS3V204LE](#)  
[ADG3245BRUZ-REEL7](#) [ADG3123BRUZ](#) [ADG3245BRUZ](#) [ADG3246BCPZ](#) [ADG3308BCPZ-REEL](#) [ADG3233BRJZ-REEL7](#)  
[ADG3233BRMZ](#)