

NS5B1G384

Single (NC) Normally Closed SPST Analog Switch

The NS5B1G384 is Single Pole Single Throw (SPST) high-speed TTL-compatible switch. The low resistance and capacitance characteristics of this switch make it ideal for low-distortion audio, video, and data routing applications. The switch has a normally closed logic configuration meaning the switch is on (NC connected to COM) when IN is low. These switches are available in 5-pin SC-70 and 5-pin TSOP-5 (SOT23-5) packages for operation over the industrial (-40°C to +85°C) temperature range.

Features

- V_{CC} Operating Range: 2.0 V to 5.5 V
- Low On Resistance : R_{ON} : 4.0 Ω Typical @ $V_{CC} = 4.5$ V
- Minimal Propagation Delay : $t_{pd} < 0.5$ ns
- Control Input Compatible with TTL Levels
- ESD Performance: Human Body Model $> \pm 2$ kV
- 5-Pin SC-70 or 5-Pin TSOP-5 Packages Available
- These are Pb-Free Devices

Typical Applications

- Audio, Video, and High-Speed Data Switching
- Mobile Phones
- Portable Devices
- Desktop & Notebook Computing



ON Semiconductor®

<http://onsemi.com>

MARKING DIAGRAMS



SC-70
CASE 419A

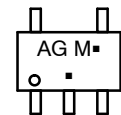

TSOP-5
(SOT23-5)
CASE 483

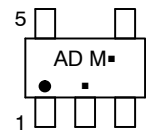

AG = For SC-70

AD = For TSOP-5

M = Date Code

▪ = Pb-Free Package

(Note: Microdot may be in either location)

LOGIC DIAGRAM

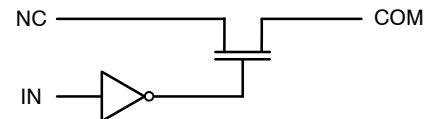

PIN ASSIGNMENTS

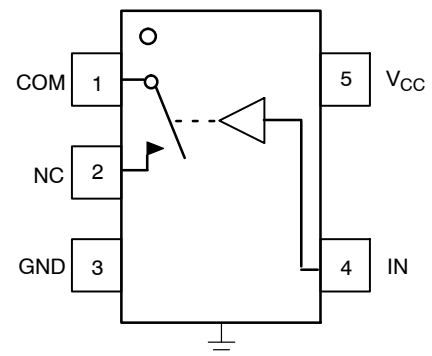

ORDERING INFORMATION

See detailed ordering and shipping information in the package dimensions section on page 4 of this data sheet.

NS5B1G384

PIN DESCRIPTION

PIN #	Name	Direction	Description
1	COM	I/O	Common Signal Line
2	NC	I/O	Normally Closed Signal Line
3	GND	Input	Ground
4	IN	Input	Control Signal Line
5	V _{CC}	Input	Voltage Supply

TRUTH TABLE

IN Control Input	Function
L	NC Connected to COM
H	NC Disconnected from COM

MAXIMUM RATINGS

Symbol	Pins	Rating	Value	Condition	Unit
V _{CC}	V _{CC}	Positive DC Supply Voltage	-0.5 to +7.0		V
V _{IS}	NC or COM	Analog Signal Voltage	-0.5 to V _{CC} + 0.5		V
V _{IN}	IN	Control Input Voltage	-0.5 to +7.0		V
I _{IS_CON}	NC or COM	Analog Signal Continuous Current	± 300	Closed Switch	mA
I _{IS_PK}	NC or COM	Analog Signal Peak Current	± 500	10% Duty Cycle	mA
I _{IN}	IN	Control Input Current	± 20		mA
T _{STG}		Storage Temperature Range	-65 to 150		°C

Stresses exceeding Maximum Ratings may damage the device. Maximum Ratings are stress ratings only. Functional operation above the Recommended Operating Conditions is not implied. Extended exposure to stresses above the Recommended Operating Conditions may affect device reliability.

RECOMMENDED OPERATING CONDITIONS

Symbol	Pins	Parameter	Value	Condition	Unit
V _{CC}	V _{CC}	Positive DC Supply Voltage	2.0 to 5.5		V
V _{IS}	NC or COM	Analog Signal Voltage	GND to V _{CC}		V
V _{IN}	IN	Control Input Voltage	GND to 5.5		V
T _A		Operating Temperature Range	-40 to +85		°C
t _r , t _f		Input Rise or Fall Time	20	V _{CC} = 3.3 V	ns/V
			10	V _{CC} = 5.0 V	

Minimum and maximum values are guaranteed through test or design across the **Recommended Operating Conditions**, where applicable. Typical values are listed for guidance only and are based on the particular conditions listed for each section, where applicable. These conditions are valid for all values found in the characteristics tables unless otherwise specified in the test conditions.

ESD PROTECTION

Pins	Description	Minimum Voltage
All Pins	Human Body Model	2 kV

NS5B1G384

DC ELECTRICAL CHARACTERISTICS

CONTROL INPUT (Typical: T = 25°C)

Symbol	Pins	Parameter	Test Conditions	V _{CC} (V)	-40°C to +85°C			Unit
					Min	Typ	Max	
V _{IH}	IN	Control Input High		4.5 – 5.5	2.0			V
V _{IL}	IN	Control Input Low		4.5 – 5.5			0.8	V
I _{IN}	IN	Control Input Leakage	0 ≤ V _{IN} ≤ V _{CC}	5.0		±0.1	±0.5	μA

SUPPLY CURRENT AND LEAKAGE (Typical: T = 25°C)

Symbol	Pins	Parameter	Test Conditions	V _{CC} (V)	-40°C to +85°C			Unit
					Min	Typ	Max	
I _{NC} (OFF)	NC	OFF State Leakage	V _{IN} = V _{IL} or V _{IH} V _{NC} = 1.0 V V _{COM} = 4.5 V	5.5		±10	±100	nA
I _{COM} (OFF)	COM	OFF State Leakage	V _{IN} = V _{IL} or V _{IH} V _{NC} = 4.5 V V _{COM} = 1.0 V	5.5		±10	±100	nA
I _{CC}	V _{CC}	Quiescent Supply	V _{IN} and V _{IS} = V _{CC} or GND I _D = 0 A	2.0 – 5.5		±0.1	±1.0	μA
I _{OFF}	IN	Power Off Leakage	V _{IN} = 5.5 V or GND	0		±0.5	±1.0	μA

ON RESISTANCE (Typical: T = 25°C)

Symbol	Pins	Parameter	Test Conditions	V _{CC} (V)	-40°C to +85°C			Unit
					Min	Typ	Max	
R _{ON}	NC, COM	ON Resistance	V _{IS} = 0 V, I _{ON} = 30 mA V _{IS} = 0 V, I _{ON} = 64 mA V _{IS} = 2.4 V, I _{ON} = 15 mA	4.5 4.5 4.5		4.0 4.0 11.5	7.0 7.0 15	Ω

NS5B1G384

AC ELECTRICAL CHARACTERISTICS

TIMING/FREQUENCY (Typical: T = 25°C, R_L = 50 Ω, C_L = 35 pF, f = 1 MHz)

Symbol	Pins	Parameter	Test Conditions	V _{CC} (V)	-40°C to +85°C			Unit
					Min	Typ	Max	
t _{ON}	IN to NC	Turn On Time	As Above, Figures 1 and 2	4.5			6.0	ns
t _{OFF}	IN to NC	Turn Off Time	As Above, Figures 1 and 2	4.5			2.0	ns
t _{PD}	NC to COM	Propagation Delay		4.5			0.5	ns
BW		-3dB Bandwidth	C _L = 5 pF, Figures 3 and 4	4.5		330		MHz

CAPACITANCE (Typical: T = 25°C, R_L = 50 Ω, C_L = 5 pF, f = 1 MHz)

Symbol	Pins	Parameter	Test Conditions	V _{CC} (V)	-40°C to +85°C			Unit
					Min	Typ	Max	
C _{IN}	IN	Control Input		0 V		2.2		pF
C _{ON}	NC to COM	Through Switch	V _{IN} = 0V	4.5 V		12		pF
C _{OFF}	NC	Unselected Port	V _{IS} = 4.5 V, V _{IN} = 4.5 V	4.5 V		4.1		pF

DEVICE ORDERING INFORMATION

Device Order Number	Package Type	Tape & Reel Size [†]
NS5B1G384DFT2G	SC-70 (Pb-Free)	3000 / Tape & Reel
NS5B1G384DTT1G	TSOP-5 (Pb-Free)	3000 / Tape & Reel

[†]For information on tape and reel specifications, including part orientation and tape sizes, please refer to our Tape and Reel Packaging Specifications Brochure, BRD8011/D.

NS5B1G384

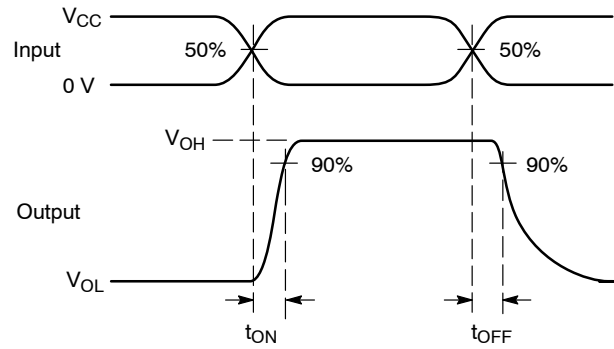
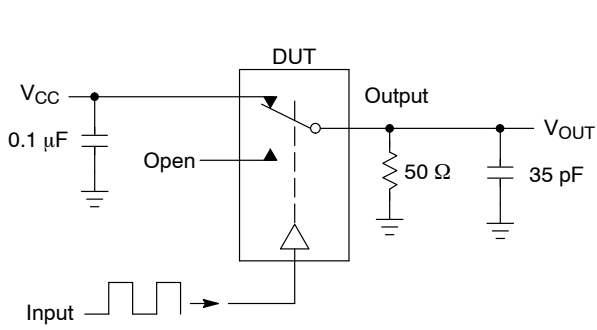

Figure 1. t_{ON}/t_{OFF}

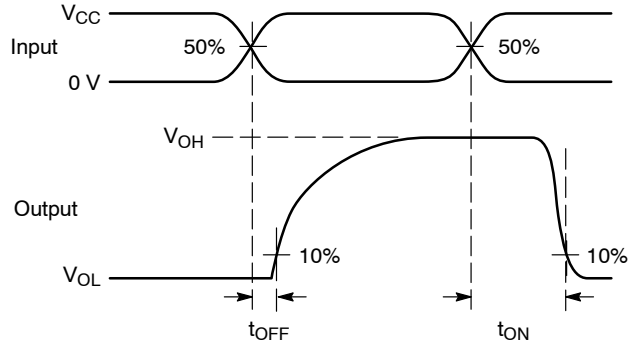
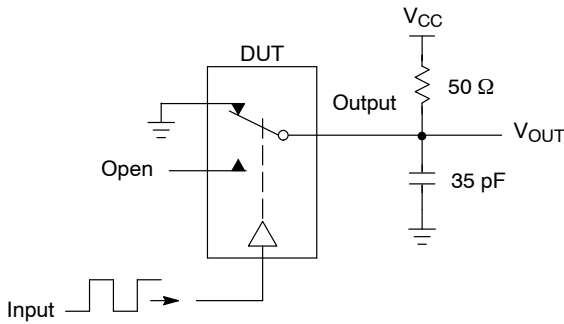
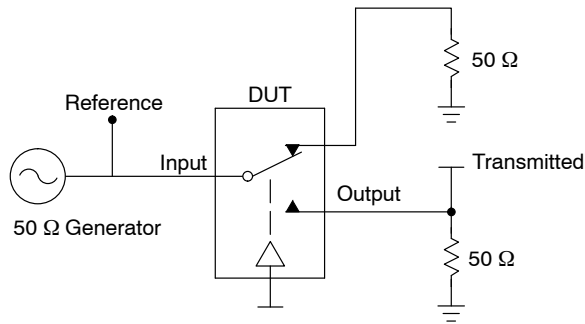

Figure 2. t_{ON}/t_{OFF}



Channel switch control/s test socket is normalized. Off isolation is measured across an off channel. On loss is the bandwidth of an On switch. V_{ISO} , Bandwidth and V_{ONL} are independent of the input signal direction.

$$V_{ISO} = \text{Off Channel Isolation} = 20 \text{ Log} \left(\frac{V_{OUT}}{V_{IN}} \right) \text{ for } V_{IN} \text{ at } 100 \text{ kHz}$$

$$V_{ONL} = \text{On Channel Loss} = 20 \text{ Log} \left(\frac{V_{OUT}}{V_{IN}} \right) \text{ for } V_{IN} \text{ at } 100 \text{ kHz to } 50 \text{ MHz}$$

Bandwidth (BW) = the frequency 3 dB below V_{ONL}

V_{CT} = Use V_{ISO} setup and test to all other switch analog input/outputs terminated with 50 Ω

Figure 3. Off Channel Isolation/On Channel Loss (BW)/Crosstalk (On Channel to Off Channel)/ V_{ONL}

NS5B1G384

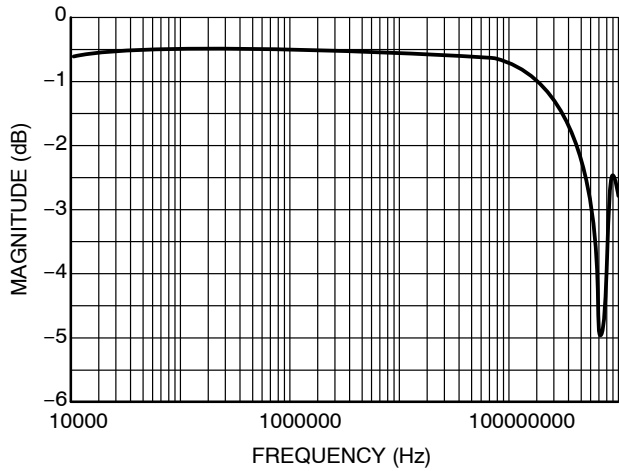

Figure 4. Typical Bandwidth @ $V_{CC} = 5.5$ V, 25°C

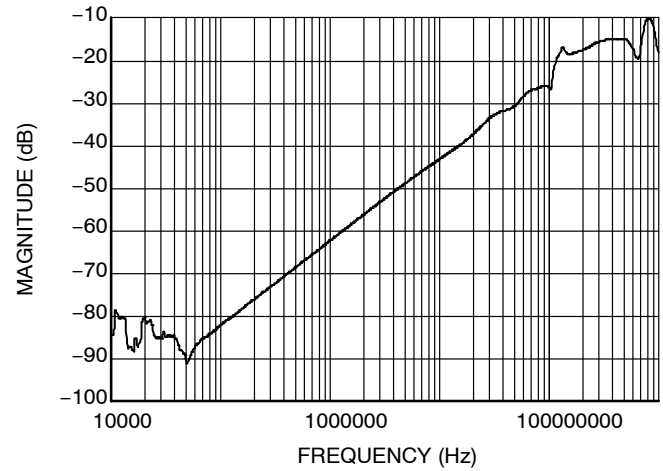

Figure 5. Off-Channel Isolation @ $V_{CC} = 5.5$ V, 25°C

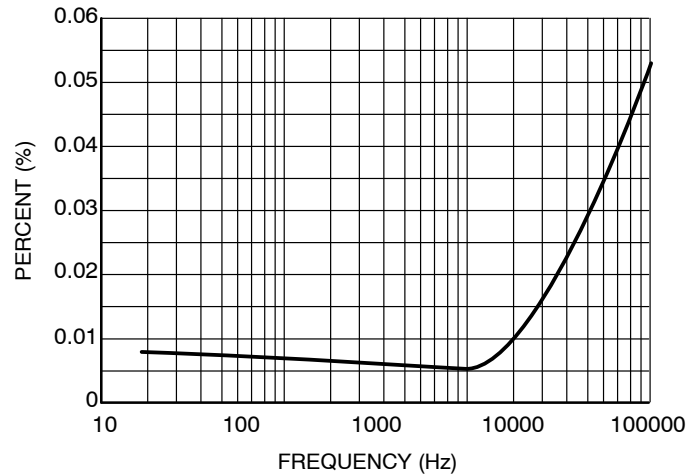

Figure 6. Typical Total Harmonic Distortion @ $V_{CC} = 4.5$ V

MECHANICAL CASE OUTLINE PACKAGE DIMENSIONS

ON Semiconductor®



SCALE 2:1

SC-88A (SC-70-5/SOT-353)
CASE 419A-02
ISSUE L

DATE 17 JAN 2013

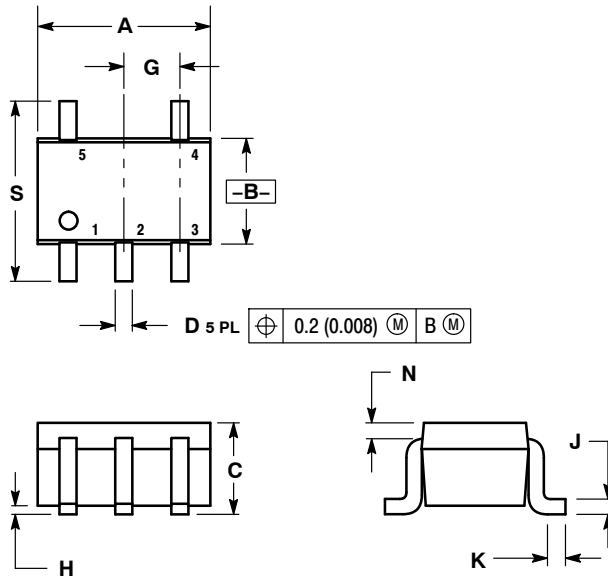

SOLDER FOOTPRINT

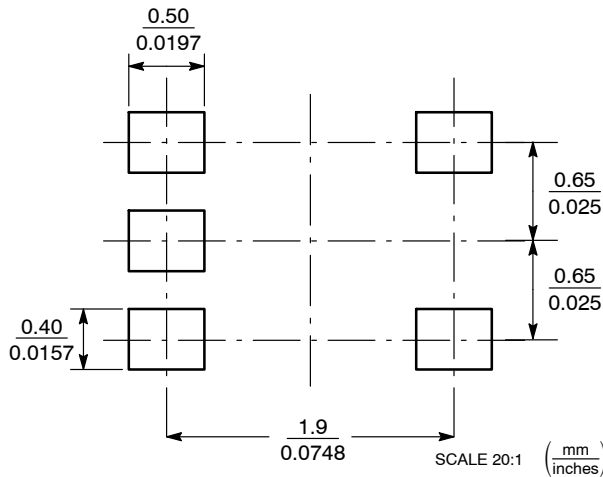

NOTES:

1. DIMENSIONING AND TOLERANCING PER ANSI Y14.5M, 1982.
2. CONTROLLING DIMENSION: INCH.
3. 419A-01 OBSOLETE. NEW STANDARD 419A-02.
4. DIMENSIONS A AND B DO NOT INCLUDE MOLD FLASH, PROTRUSIONS, OR GATE BURRS.

DIM	INCHES		MILLIMETERS	
	MIN	MAX	MIN	MAX
A	0.071	0.087	1.80	2.20
B	0.045	0.053	1.15	1.35
C	0.031	0.043	0.80	1.10
D	0.004	0.012	0.10	0.30
G	0.026 BSC		0.65 BSC	
H	---	0.004	---	0.10
J	0.004	0.010	0.10	0.25
K	0.004	0.012	0.10	0.30
N	0.008 REF		0.20 REF	
S	0.079	0.087	2.00	2.20

GENERIC MARKING DIAGRAM*

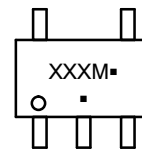

- XXX = Specific Device Code
- M = Date Code
- = Pb-Free Package

(Note: Microdot may be in either location)

*This information is generic. Please refer to device data sheet for actual part marking. Pb-Free indicator, "G" or microdot "■", may or may not be present. Some products may not follow the Generic Marking.

- | | | | | |
|--|--|--|--|--|
| <p>STYLE 1:
PIN 1. BASE
2. EMITTER
3. BASE
4. COLLECTOR
5. COLLECTOR</p> | <p>STYLE 2:
PIN 1. ANODE
2. EMITTER
3. BASE
4. COLLECTOR
5. CATHODE</p> | <p>STYLE 3:
PIN 1. ANODE 1
2. N/C
3. ANODE 2
4. CATHODE 2
5. CATHODE 1</p> | <p>STYLE 4:
PIN 1. SOURCE 1
2. DRAIN 1/2
3. SOURCE 1
4. GATE 1
5. GATE 2</p> | <p>STYLE 5:
PIN 1. CATHODE
2. COMMON ANODE
3. CATHODE 2
4. CATHODE 3
5. CATHODE 4</p> |
| <p>STYLE 6:
PIN 1. EMITTER 2
2. BASE 2
3. EMITTER 1
4. COLLECTOR
5. COLLECTOR 2/BASE 1</p> | <p>STYLE 7:
PIN 1. BASE
2. EMITTER
3. BASE
4. COLLECTOR
5. COLLECTOR</p> | <p>STYLE 8:
PIN 1. CATHODE
2. COLLECTOR
3. N/C
4. BASE
5. EMITTER</p> | <p>STYLE 9:
PIN 1. ANODE
2. CATHODE
3. ANODE
4. ANODE
5. ANODE</p> | <p>Note: Please refer to datasheet for style callout. If style type is not called out in the datasheet refer to the device datasheet pinout or pin assignment.</p> |

DOCUMENT NUMBER:	98ASB42984B	Electronic versions are uncontrolled except when accessed directly from the Document Repository. Printed versions are uncontrolled except when stamped "CONTROLLED COPY" in red.
DESCRIPTION:	SC-88A (SC-70-5/SOT-353)	PAGE 1 OF 1

ON Semiconductor and ON are trademarks of Semiconductor Components Industries, LLC dba ON Semiconductor or its subsidiaries in the United States and/or other countries. ON Semiconductor reserves the right to make changes without further notice to any products herein. ON Semiconductor makes no warranty, representation or guarantee regarding the suitability of its products for any particular purpose, nor does ON Semiconductor assume any liability arising out of the application or use of any product or circuit, and specifically disclaims any and all liability, including without limitation special, consequential or incidental damages. ON Semiconductor does not convey any license under its patent rights nor the rights of others.

MECHANICAL CASE OUTLINE PACKAGE DIMENSIONS

ON Semiconductor®

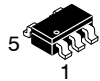

SCALE 2:1

TSOP-5 CASE 483 ISSUE N

DATE 12 AUG 2020

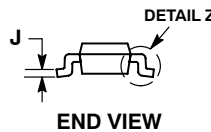
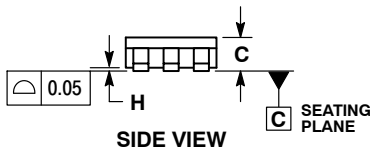
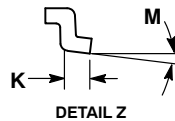
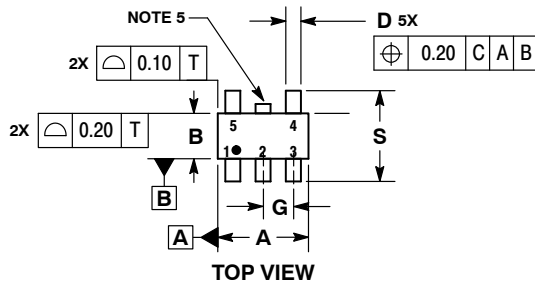

NOTES:

1. DIMENSIONING AND TOLERANCING PER ASME Y14.5M, 1994.
2. CONTROLLING DIMENSION: MILLIMETERS.
3. MAXIMUM LEAD THICKNESS INCLUDES LEAD FINISH THICKNESS. MINIMUM LEAD THICKNESS IS THE MINIMUM THICKNESS OF BASE MATERIAL.
4. DIMENSIONS A AND B DO NOT INCLUDE MOLD FLASH, PROTRUSIONS, OR GATE BURRS. MOLD FLASH, PROTRUSIONS, OR GATE BURRS SHALL NOT EXCEED 0.15 PER SIDE. DIMENSION A.
5. OPTIONAL CONSTRUCTION: AN ADDITIONAL TRIMMED LEAD IS ALLOWED IN THIS LOCATION. TRIMMED LEAD NOT TO EXTEND MORE THAN 0.2 FROM BODY.

DIM	MILLIMETERS	
	MIN	MAX
A	2.85	3.15
B	1.35	1.65
C	0.90	1.10
D	0.25	0.50
G	0.95 BSC	
H	0.01	0.10
J	0.10	0.26
K	0.20	0.60
M	0°	10°
S	2.50	3.00

SOLDERING FOOTPRINT*

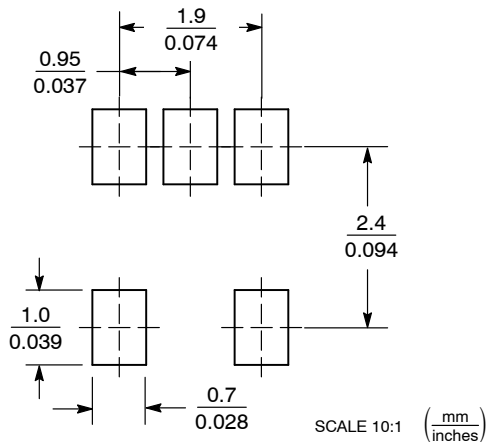

GENERIC MARKING DIAGRAM*

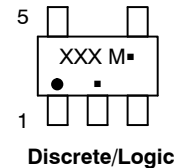
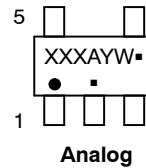

- XXX = Specific Device Code XXX = Specific Device Code
 A = Assembly Location M = Date Code
 Y = Year ■ = Pb-Free Package
 W = Work Week
 ■ = Pb-Free Package

(Note: Microdot may be in either location)

*This information is generic. Please refer to device data sheet for actual part marking. Pb-Free indicator, "G" or microdot "■", may or may not be present.

*For additional information on our Pb-Free strategy and soldering details, please download the ON Semiconductor Soldering and Mounting Techniques Reference Manual, SOLDERRM/D.

DOCUMENT NUMBER:	98ARB18753C	Electronic versions are uncontrolled except when accessed directly from the Document Repository. Printed versions are uncontrolled except when stamped "CONTROLLED COPY" in red.
DESCRIPTION:	TSOP-5	PAGE 1 OF 1

ON Semiconductor and ON are trademarks of Semiconductor Components Industries, LLC dba ON Semiconductor or its subsidiaries in the United States and/or other countries. ON Semiconductor reserves the right to make changes without further notice to any products herein. ON Semiconductor makes no warranty, representation or guarantee regarding the suitability of its products for any particular purpose, nor does ON Semiconductor assume any liability arising out of the application or use of any product or circuit, and specifically disclaims any and all liability, including without limitation special, consequential or incidental damages. ON Semiconductor does not convey any license under its patent rights nor the rights of others.

onsemi, **Onsemi**, and other names, marks, and brands are registered and/or common law trademarks of Semiconductor Components Industries, LLC dba "**onsemi**" or its affiliates and/or subsidiaries in the United States and/or other countries. **onsemi** owns the rights to a number of patents, trademarks, copyrights, trade secrets, and other intellectual property. A listing of **onsemi**'s product/patent coverage may be accessed at www.onsemi.com/site/pdf/Patent-Marking.pdf. **onsemi** reserves the right to make changes at any time to any products or information herein, without notice. The information herein is provided "as-is" and **onsemi** makes no warranty, representation or guarantee regarding the accuracy of the information, product features, availability, functionality, or suitability of its products for any particular purpose, nor does **onsemi** assume any liability arising out of the application or use of any product or circuit, and specifically disclaims any and all liability, including without limitation special, consequential or incidental damages. Buyer is responsible for its products and applications using **onsemi** products, including compliance with all laws, regulations and safety requirements or standards, regardless of any support or applications information provided by **onsemi**. "Typical" parameters which may be provided in **onsemi** data sheets and/or specifications can and do vary in different applications and actual performance may vary over time. All operating parameters, including "Typicals" must be validated for each customer application by customer's technical experts. **onsemi** does not convey any license under any of its intellectual property rights nor the rights of others. **onsemi** products are not designed, intended, or authorized for use as a critical component in life support systems or any FDA Class 3 medical devices or medical devices with a same or similar classification in a foreign jurisdiction or any devices intended for implantation in the human body. Should Buyer purchase or use **onsemi** products for any such unintended or unauthorized application, Buyer shall indemnify and hold **onsemi** and its officers, employees, subsidiaries, affiliates, and distributors harmless against all claims, costs, damages, and expenses, and reasonable attorney fees arising out of, directly or indirectly, any claim of personal injury or death associated with such unintended or unauthorized use, even if such claim alleges that **onsemi** was negligent regarding the design or manufacture of the part. **onsemi** is an Equal Opportunity/Affirmative Action Employer. This literature is subject to all applicable copyright laws and is not for resale in any manner.

PUBLICATION ORDERING INFORMATION

LITERATURE FULFILLMENT:

Email Requests to: orderlit@onsemi.com

onsemi Website: www.onsemi.com

TECHNICAL SUPPORT

North American Technical Support:

Voice Mail: 1 800-282-9855 Toll Free USA/Canada

Phone: 011 421 33 790 2910

Europe, Middle East and Africa Technical Support:

Phone: 00421 33 790 2910

For additional information, please contact your local Sales Representative

X-ON Electronics

Largest Supplier of Electrical and Electronic Components

Click to view similar products for [Analogue Switch ICs](#) category:

Click to view products by [ON Semiconductor](#) manufacturer:

Other Similar products are found below :

[FSA3051TMX](#) [NLAS4684FCTCG](#) [NLAS5223BLMNR2G](#) [NLX2G66DMUTCG](#) [425541DB](#) [425528R](#) [099044FB](#) [NLAS5123MNR2G](#)
[PI5A4157CEX](#) [NLAS4717EPFCT1G](#) [PI5A3167CCEX](#) [SLAS3158MNR2G](#) [PI5A392AQE](#) [PI5A4157ZUEX](#) [PI5A3166TAEX](#) [FSA634UCX](#)
[XS3A1T3157GMX](#) [TC4066BP\(N,F\)](#) [DG302BDJ-E3](#) [PI5A100QEX](#) [HV2605FG-G](#) [HV2301FG-G](#) [RS2117YUTQK10](#) [RS2118YUTQK10](#)
[RS2227XUTQK10](#) [ADG452BRZ-REEL7](#) [MAX4066ESD+](#) [MAX391CPE+](#) [MAX4730EXT+T](#) [MAX314CPE+](#) [BU4066BCFV-E2](#)
[MAX313CPE+](#) [BU4S66G2-TR](#) [NLASB3157MTR2G](#) [TS3A4751PWR](#) [NLAST4599DFT2G](#) [NLAST4599DTT1G](#) [DG300BDJ-E3](#)
[DG2503DB-T2-GE1](#) [TC4W53FU\(Te12L,F\)](#) [74HC2G66DC.125](#) [DG3257DN-T1-GE4](#) [ADG619BRMZ-REEL](#) [ADG1611BRUZ-REEL7](#)
[DG2535EDQ-T1-GE3](#) [LTC201ACN#PBF](#) [74LV4066DB,118](#) [ISL43410IUZ](#) [FSA2275AUMX](#) [DIO1500WL12](#)