

NV8664ST50T3GEVB

NCV8664 Evaluation Board User's Manual



ON Semiconductor®

<http://onsemi.com>

EVAL BOARD USER'S MANUAL

Description

The NCV8664 is a precision 3.3 V and 5.0 V fixed output, low dropout integrated voltage regulator with an output current capability of 150 mA. Careful management of light load current consumption, combined with a low leakage process, achieve a typical quiescent ground current of 22 μ A. The output voltage is accurate within $\pm 2.0\%$, and maximum dropout voltage is 600 mV at full rated load current. The following ceramic capacitors are the recommended values to be used with these devices; $C_{in} = 0.1 \mu$ F, $C_{out} = 10 \mu$ F.

Features

- $\pm 2.0\%$ Output Accuracy, Over Full Temperature Range
- 30 μ A Maximum Quiescent Current at $I_{out} = 100 \mu$ A
- 600 mV Maximum Dropout Voltage at 150 mA Load Current

- Wide Input Voltage Operating Range of 5.5 V to 45 V
- Internal Fault Protection
 - -42 V Reverse Voltage
 - Short Circuit/Overcurrent
 - Thermal Overload

Board Notes

Max voltage on V_{in} cap not to exceed 35 V.

Board Layouts

These boards are shown in sets of 2 due to the minimum board size requirement of most board fabrication houses. When sent out for fabrication, it must be indicated that the center line of the board set be V-scored to allow board separation.

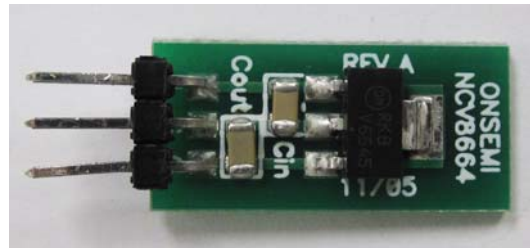

Figure 1. Evaluation Board Photo

NV8664ST50T3GEVB

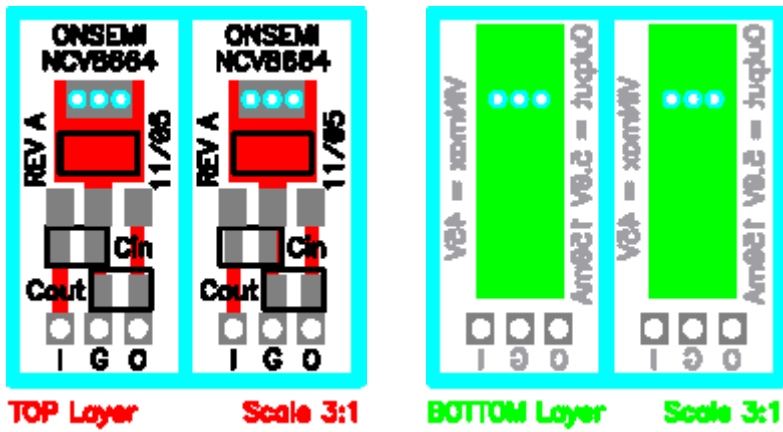

Figure 2. SOT-223 Evaluation Board

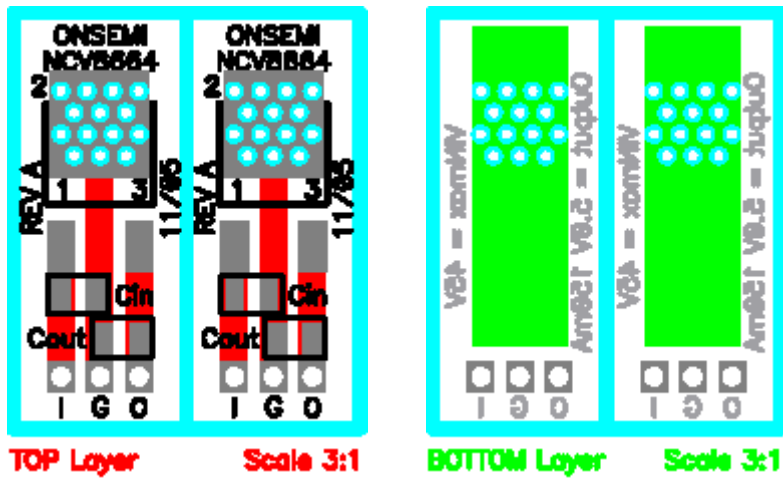

Figure 3. DPAK Evaluation Board

SCHEMATIC FOR THE NCV8664 EVALUATION BOARD

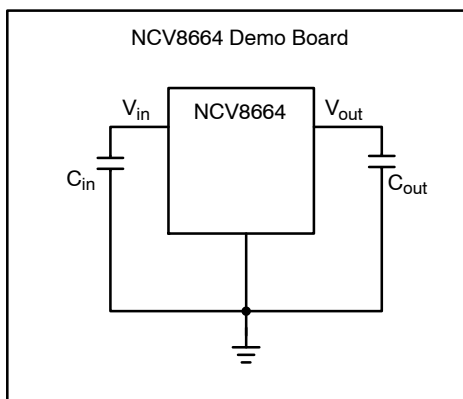

Figure 4. NCV8664 Evaluation Board Circuit

NV8664ST50T3GEVB

Table 1. BILL OF MATERIALS FOR THE NCV8664 EVALUATION BOARD

Value	Tolerance	Footprint	Manufacturer	Part Number	Substitution Allowed	Lead Free
-------	-----------	-----------	--------------	-------------	----------------------	-----------

SOT223 BOM

-	-	-	Advanced Circuits	NCV8664DPAK3DemoBoard	No	Yes
-	-	SOT223	On Semiconductor	NCV8664ST50R3G	No	Yes
-	-	-	Molex/Waldom Electronics Corporation	22-28-8030	Yes	Yes
0.1 μ F	10%	1206	Murata Electronics North America	GRM319R71H104KA01D	Yes	Yes
10 μ F	10%	1206	Murata Electronics North America	GRM31CR71C106KAC7L	Yes	Yes

DPAK BOM

-	-	-	Advanced Circuits	NCV8664DPAK3DemoBoard	No	Yes
-	-	DPAK	On Semiconductor	NCV8664DT50RKG	No	Yes
-	-	-	Molex/Waldom Electronics Corporation	22-28-8030	Yes	Yes
0.1 μ F	10%	1206	Murata Electronics North America	GRM319R71H104KA01D	Yes	Yes
10 μ F	10%	1206	Murata Electronics North America	GRM31CR71C106KAC7L	Yes	Yes

Test Procedure

Required Equipment:

- Resistive Load
- 2 Multimeters
- One NCV8664 Evaluation Board
- DC Power Supply

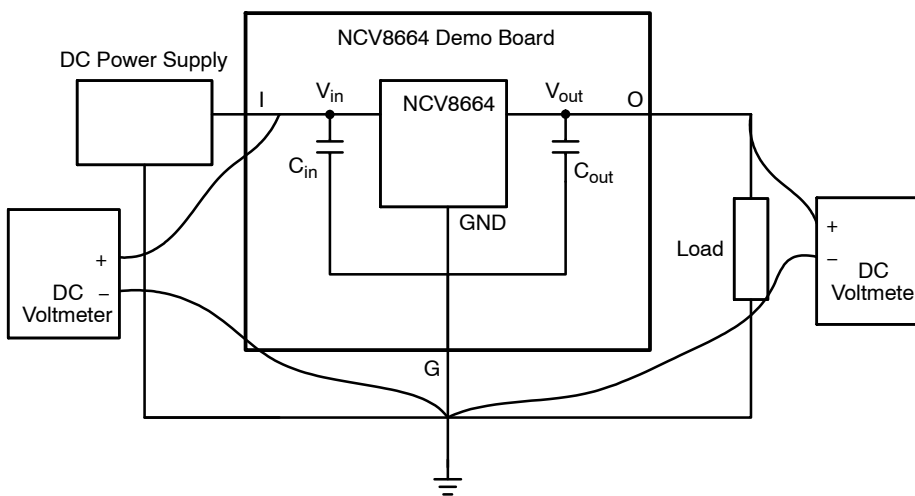

Figure 5. Dropout Voltage Test Setup

Dropout Voltage Verification Steps

1. Connect circuit as shown in Figure 5.
2. Set $V_{in} = 13.5$ V, Record V_{out} .
3. Reduce V_{in} until V_{out} has dropped by 100 mV.
4. Subtract V_{out} from V_{in} . Resulting Voltage is Dropout Voltage.

NV8664ST50T3GEVB

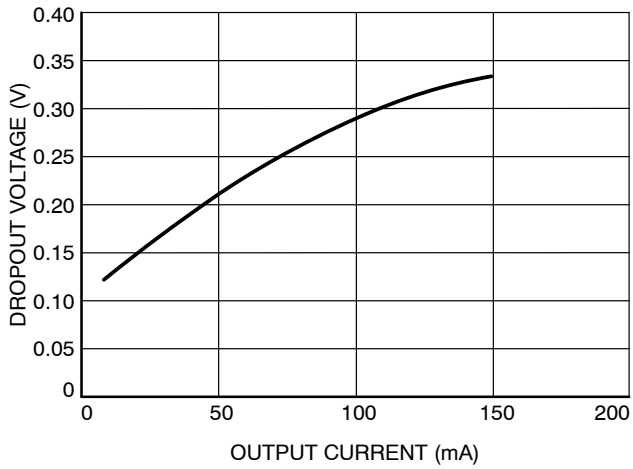

Figure 6. Dropout Voltage vs. Output Current

Quiescent Current Verification Steps

1. Connect circuit as shown in Figure 7.
2. Set $V_{in} = 13.5$ V.
3. Subtract Output Current from Input Current.

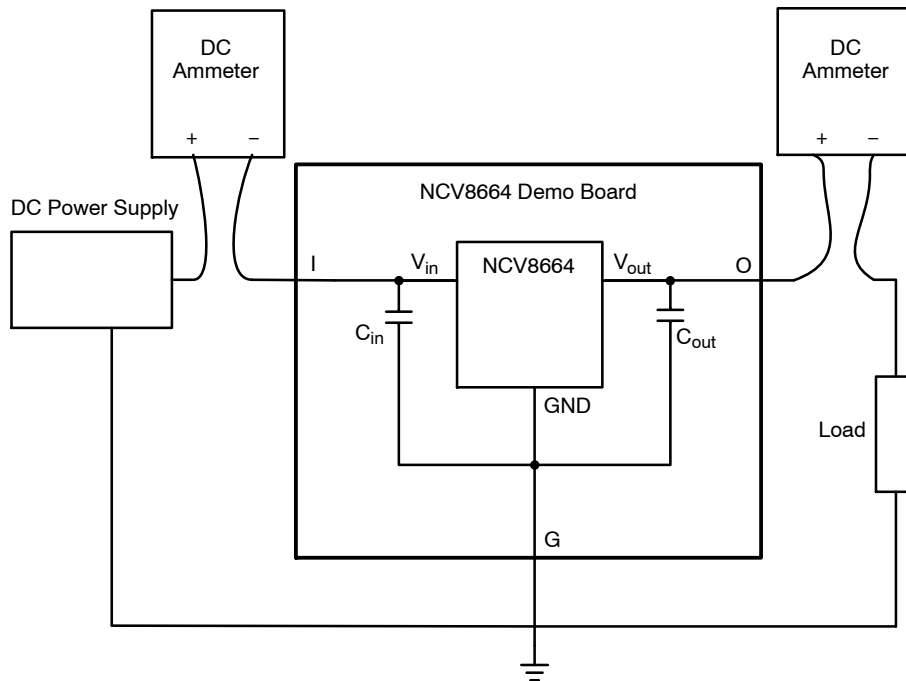

Figure 7. Quiescent Current Verification Setup

NV8664ST50T3GEVB

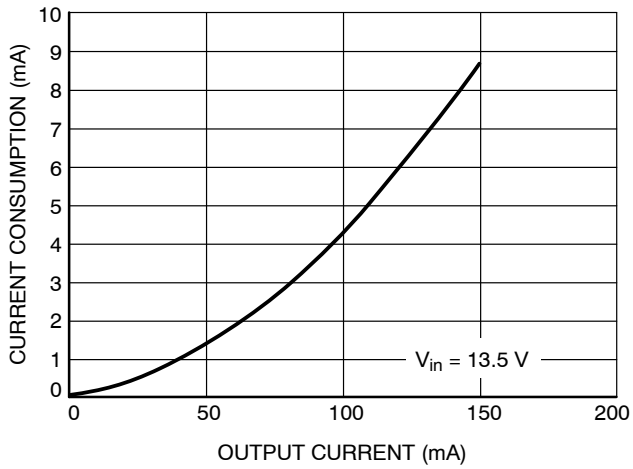

Figure 8. Current Consumption vs. Output Current

Output Voltage Verification Steps

1. Connect circuit as shown in Figure 9.
2. Set output load to $100\ \Omega$, Set $V_{in} = 0\ \text{V}$, Record V_{out} .
3. Increase V_{in} , measure V_{out} .

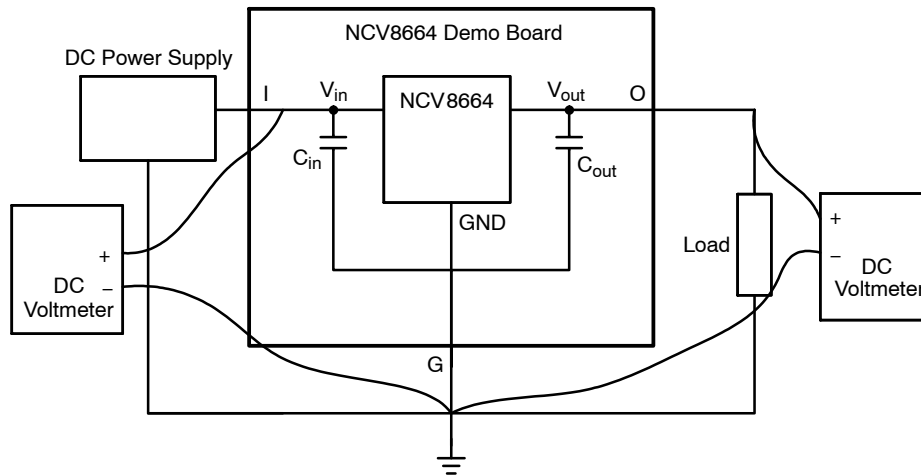

Figure 9. Quiescent Current Verification Setup

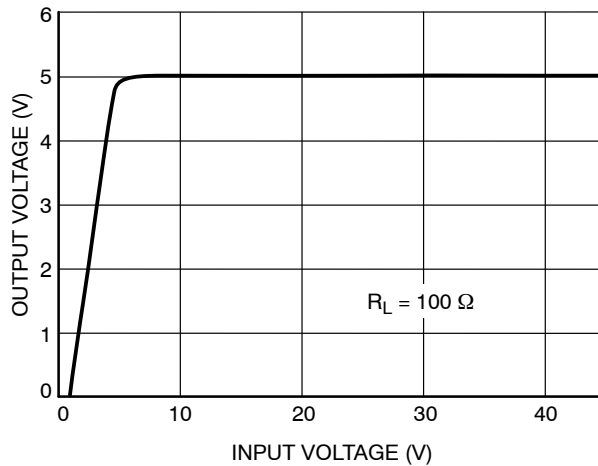



Figure 10. Input Voltage vs. Output Voltage

NV8664ST50T3GEVB

ON Semiconductor and  are registered trademarks of Semiconductor Components Industries, LLC (SCILLC). SCILLC reserves the right to make changes without further notice to any products herein. SCILLC makes no warranty, representation or guarantee regarding the suitability of its products for any particular purpose, nor does SCILLC assume any liability arising out of the application or use of any product or circuit, and specifically disclaims any and all liability, including without limitation special, consequential or incidental damages. "Typical" parameters which may be provided in SCILLC data sheets and/or specifications can and do vary in different applications and actual performance may vary over time. All operating parameters, including "Typicals" must be validated for each customer application by customer's technical experts. SCILLC does not convey any license under its patent rights nor the rights of others. SCILLC products are not designed, intended, or authorized for use as components in systems intended for surgical implant into the body, or other applications intended to support or sustain life, or for any other application in which the failure of the SCILLC product could create a situation where personal injury or death may occur. Should Buyer purchase or use SCILLC products for any such unintended or unauthorized application, Buyer shall indemnify and hold SCILLC and its officers, employees, subsidiaries, affiliates, and distributors harmless against all claims, costs, damages, and expenses, and reasonable attorney fees arising out of, directly or indirectly, any claim of personal injury or death associated with such unintended or unauthorized use, even if such claim alleges that SCILLC was negligent regarding the design or manufacture of the part. SCILLC is an Equal Opportunity/Affirmative Action Employer. This literature is subject to all applicable copyright laws and is not for resale in any manner.

PUBLICATION ORDERING INFORMATION

LITERATURE FULFILLMENT:

Literature Distribution Center for ON Semiconductor
P.O. Box 5163, Denver, Colorado 80217 USA
Phone: 303-675-2175 or 800-344-3860 Toll Free USA/Canada
Fax: 303-675-2176 or 800-344-3867 Toll Free USA/Canada
Email: orderlit@onsemi.com

N. American Technical Support: 800-282-9855 Toll Free
USA/Canada
Europe, Middle East and Africa Technical Support:
Phone: 421 33 790 2910
Japan Customer Focus Center
Phone: 81-3-5817-1050

ON Semiconductor Website: www.onsemi.com
Order Literature: <http://www.onsemi.com/orderlit>
For additional information, please contact your local
Sales Representative

X-ON Electronics

Largest Supplier of Electrical and Electronic Components

Click to view similar products for [Power Management IC Development Tools](#) *category:*

Click to view products by [ON Semiconductor](#) *manufacturer:*

Other Similar products are found below :

[EVAL-ADM1168LQEBZ](#) [EVB-EP5348UI](#) [MIC23451-AAAYFL EV](#) [MIC5281YMME EV](#) [DA9063-EVAL](#) [ADP122-3.3-EVALZ](#) [ADP130-0.8-EVALZ](#) [ADP130-1.2-EVALZ](#) [ADP130-1.5-EVALZ](#) [ADP130-1.8-EVALZ](#) [ADP1712-3.3-EVALZ](#) [ADP1714-3.3-EVALZ](#) [ADP1715-3.3-EVALZ](#) [ADP1716-2.5-EVALZ](#) [ADP1740-1.5-EVALZ](#) [ADP1752-1.5-EVALZ](#) [ADP1828LC-EVALZ](#) [ADP1870-0.3-EVALZ](#) [ADP1871-0.6-EVALZ](#) [ADP1873-0.6-EVALZ](#) [ADP1874-0.3-EVALZ](#) [ADP1882-1.0-EVALZ](#) [ADP199CB-EVALZ](#) [ADP2102-1.25-EVALZ](#) [ADP2102-1.875EVALZ](#) [ADP2102-1.8-EVALZ](#) [ADP2102-2-EVALZ](#) [ADP2102-3-EVALZ](#) [ADP2102-4-EVALZ](#) [ADP2106-1.8-EVALZ](#) [ADP2147CB-110EVALZ](#) [AS3606-DB](#) [BQ24010EVM](#) [BQ24075TEVM](#) [BQ24155EVM](#) [BQ24157EVM-697](#) [BQ24160EVM-742](#) [BQ24296MEVM-655](#) [BQ25010EVM](#) [BQ3055EVM](#) [NCV891330PD50GEVB](#) [ISLUSBI2CKIT1Z](#) [LM2744EVAL](#) [LM2854EVAL](#) [LM3658SD-AEV/NOPB](#) [LM3658SDEV/NOPB](#) [LM3691TL-1.8EV/NOPB](#) [LM4510SDEV/NOPB](#) [LM5033SD-EVAL](#) [LP38512TS-1.8EV](#)