

P3MS650103H

1.8V/2.5V/3.3V, LVCMOS Peak EMI Reduction Clock Generator

Product Description

P3MS650103H device is a spread spectrum frequency modulator clock generator with 1.8 V/2.5 V/3.3 V LVCMOS output designed specifically for clock frequencies between 15 MHz and 60 MHz. P3MS650103H reduces electromagnetic interference (EMI) at the clock source, allowing system wide reduction of EMI of all clock dependent signals. The device allows significant system cost savings by reducing the number of circuit board layers, ferrite beads, and shielding that are traditionally required to pass EMI regulations.

P3MS650103H accepts an LVCMOS input from an external reference clock and locks to a 1x modulated clock output. P3MS650103H goes to power down mode for power save when no clock is present on CLKIN pin. ModOUT goes 'low' in power down mode.

P3MS650103H operates over -20°C to $+85^{\circ}\text{C}$ and is available in a 4 Pin WDFN, (1.2mmX1.0mm) Package.

Features

- Peak EMI Reduction Clock Generator with LVCMOS Output
- Supply Voltage and Input / Output Clock Frequency Range
 - 1.6 V – 2.0 V: 15 MHz – 30 MHz
 - 2.3 V – 3.6 V: 15 MHz – 60 MHz
- Frequency Deviation: $\pm 0.45\%$ @ 24 MHz
- Power Down current less than 1 μA
- 4-pin WDFN (1.2mmX1.0mm) Package
- Output Drive Current: 1.8 V: 8 mA
2.5 V/3.3 V: 16 mA
- Operating temperature range: -20°C to $+85^{\circ}\text{C}$
- These Devices are Pb-Free, Halogen Free/BFR Free and are RoHS Compliant

Applications

- P3MS650103H is targeted towards consumer electronic applications like mobile Phones, tablets, net books and MIDs

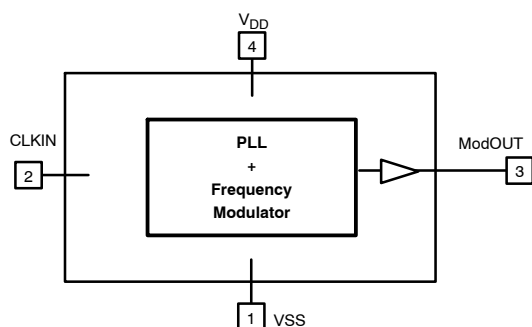

Figure 1. Simplified Block Diagram



ON Semiconductor®

<http://onsemi.com>

MARKING DIAGRAM



WDFN4
CASE 511BS



B = Specific Device Code
M = Date Code

PIN CONFIGURATION

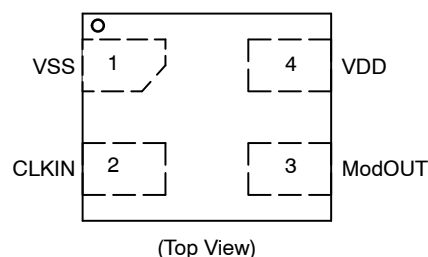

ORDERING INFORMATION

See detailed ordering and shipping information in the package dimensions section on page 6 of this data sheet.

P3MS650103H

Table 1. PIN DESCRIPTION

Pin #	Pin Name	Type	Description
1	VSS	Power	Ground connection.
2	CLKIN	Input	LVC MOS External reference clock input.
3	ModOUT	Output	Spread Spectrum Clock Output.
4	VDD	Power	Power supply for the entire chip

Table 2. OPERATING CONDITIONS

Symbol	Description	Min	Max	Unit
V_{DD} (1.8 V)	Supply Voltage with respect to V_{SS}	1.6	2.0	V
V_{DD} (2.5 V/3.3 V)		2.3	3.6	
T_A	Operating temperature	-20	+85	°C
C_L	Load Capacitance		15	pF
C_{IN}	Input Capacitance		5	pF

Table 3. ABSOLUTE MAXIMUM RATING

Symbol	Description	Rating	Unit
V_{DD}, V_{IN}	Voltage on any input pin with respect to V_{SS}	-0.5 to +4.6	V
T_{STG}	Storage temperature	-65 to +125	°C
T_s	Max. Soldering Temperature (10 sec)	260	°C
T_J	Junction Temperature	150	°C
T_{DV}	Static Discharge Voltage (As per JEDEC STD22- A114-B)	2	kV

Stresses exceeding Maximum Ratings may damage the device. Maximum Ratings are stress ratings only. Functional operation above the Recommended Operating Conditions is not implied. Extended exposure to stresses above the Recommended Operating Conditions may affect device reliability.

P3MS650103H

Table 4. DC Electrical Characteristics $V_{DD} = 1.6\text{ V} - 2.0\text{ V}$, $T_A = -20^\circ\text{C}$ to $+85^\circ\text{C}$

Symbol	Parameter	Min	Typ	Max	Unit
V_{DD}	Supply Voltage with respect to VSS	1.6	1.8	2.0	V
I_{DD}	Dynamic supply current (Unloaded Output)	15MHz	1.3	1.8	mA
		30MHz	2	2.8	
I_{CC}	Static supply current (No Clock @ CLKIN)			1	μA
V_{IH}	Input high voltage	$0.65 \cdot V_{DD}$			V
V_{IL}	Input low voltage			$0.3 \cdot V_{DD}$	V
I_{IH}	Input high current (CLKIN pin)			10	μA
I_{IL}	Input low current (CLKIN pin)			10	μA
V_{OH}	Output high voltage, $I_{OH} = -8\text{mA}$	$0.75 \cdot V_{DD}$			V
V_{OL}	Output low voltage, $I_{OL} = 8\text{mA}$			$0.2 \cdot V_{DD}$	V
Z_{OUT}	Output impedance		28		Ω

Table 5. AC ELECTRICAL CHARACTERISTICS $V_{DD} = 1.6\text{ V} - 2.0\text{ V}$, $T_A = -20^\circ\text{C}$ to $+85^\circ\text{C}$

Symbol	Parameter	Min	Typ	Max	Unit
CLKIN	Input Clock frequency	15		30	MHz
ModOUT	Output Clock frequency	15		30	MHz
t_{LH} (Notes 1 and 2)	Output rise time (Measured between 20% to 80%)		1.7	2.7	nS
t_{HL} (Notes 1 and 2)	Output fall time (Measured between 80% to 20%)		1.4	2.4	nS
t_{JC} (Notes 2)	Cycle-to-cycle Jitter, Peak (1000 cycles)	15 MHz		400	pS
		24 MHz		250	
		30 MHz			
t_D (Notes 1 and 2)	Output duty cycle (Measured @ 50%)	45	50	55	%
t_{ON} (Notes 1 and 2)	PLL lock Time (Stable power supply, valid clock presented on CLKIN)			3	mS
fd	Frequency Deviation @ 24 MHz		± 0.45	± 0.52	%

1. All parameters are specified with 15 pF loaded output.
2. Parameter is guaranteed by design and characterization. Not 100% tested in production

P3MS650103H

Table 6. DC ELECTRICAL CHARACTERISTICS $V_{DD} = 2.3\text{ V} - 3.6\text{ V}$, $T_A = -20^\circ\text{C}$ to $+85^\circ\text{C}$

Symbol	Parameter	Min	Typ	Max	Unit
V_{DD}	Supply Voltage with respect to VSS	2.3	2.8	3.6	V
I_{DD}	Dynamic supply current (Unloaded Output)	15MHz	1.7	3	mA
		30MHz	2.8	5	
		60MHz	5	9	
I_{CC}	Static supply current (No Clock @ CLKIN)			2	μA
V_{IH}	Input high voltage	$0.65 * V_{DD}$			V
V_{IL}	Input low voltage			$0.3 * V_{DD}$	V
I_{IH}	Input high current (CLKIN pin)			10	μA
I_{IL}	Input low current (CLKIN pin)			10	μA
V_{OH}	Output high voltage, $I_{OH} = -16\text{ mA}$	$0.75 * V_{DD}$			V
V_{OL}	Output low voltage, $I_{OL} = 16\text{ mA}$			$0.2 * V_{DD}$	V
Z_{OUT}	Output impedance		20		Ω

Table 7. AC ELECTRICAL CHARACTERISTICS $V_{DD} = 2.3\text{ V} - 3.6\text{ V}$, $T_A = -20^\circ\text{C}$ to $+85^\circ\text{C}$

Symbol	Parameter	Min	Typ	Max	Unit
CLKIN	Input Clock frequency	15		60	MHz
ModOUT	Output Clock frequency	15		60	MHz
t_{LH} (Notes 3 and 4)	Output rise time (Measured between 20% to 80%)		0.8	1.6	nS
t_{HL} (Notes 3 and 4)	Output fall time (Measured between 80% to 20%)		0.8	1.6	nS
t_{JC} (Notes 4)	Cycle-to-cycle Jitter, Peak (1000 cycles)	15 MHz		350	μs
		24 MHz		250	
		60 MHz		100	
t_D (Notes 3 and 4)	Output duty cycle	45	50	55	%
t_{ON} (Notes 3 and 4)	PLL lock Time (Stable power supply, valid clock presented on CLKIN)			3	mS
fd	Frequency Deviation @ 24 MHz		± 0.45	± 0.70	%

3. All parameters are specified with 15 pF loaded output.

4. Parameter is guaranteed by design and characterization. Not 100% tested in production

P3MS650103H

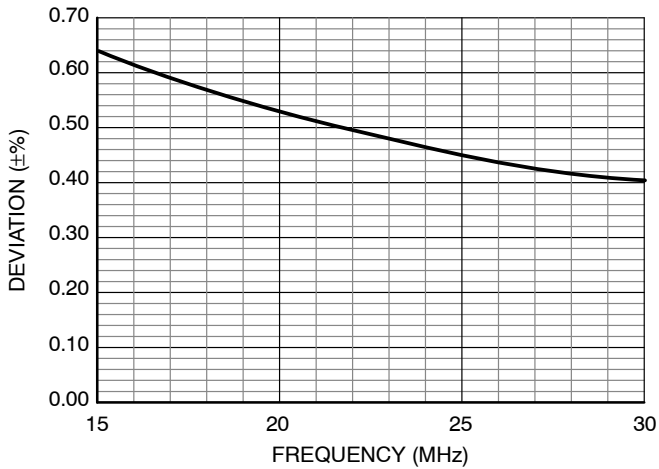

Figure 2. Deviation vs. Frequency
(V_{DD} = 1.6 V - 2.0 V)

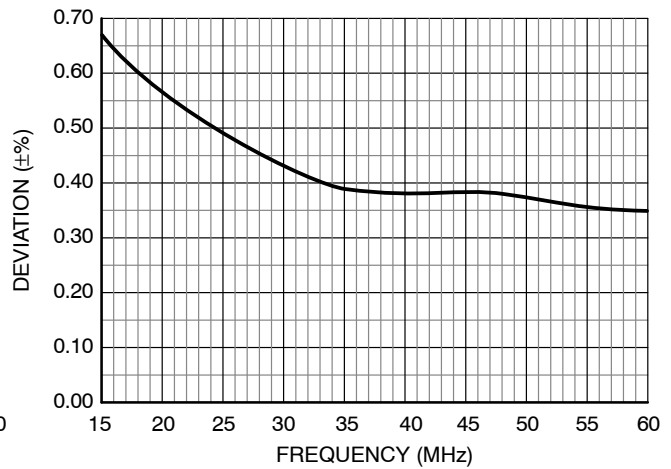
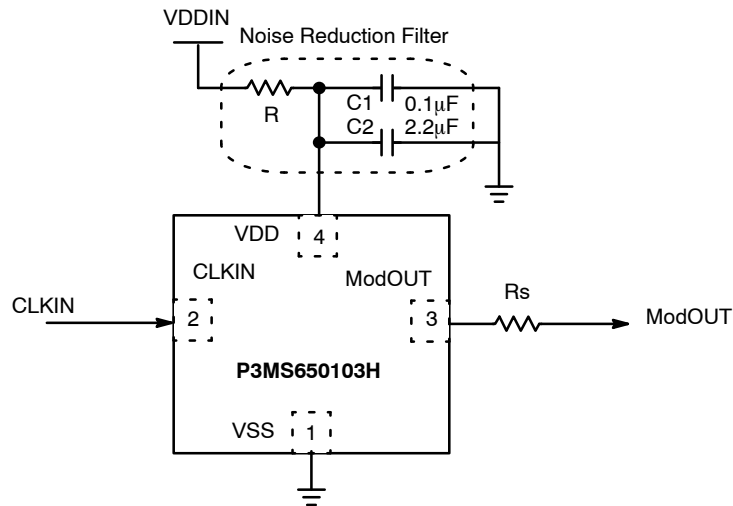

Figure 3. Deviation vs. Frequency
(V_{DD} = 2.3 V - 3.6 V)



Rs = Trace Impedance of PCB – Output Impedance of Device (Z₀)
 Note: Refer Pin Description table for Functionality details

Figure 4. Typical Application Schematic

PCB Layout Recommendation

For optimum device performance, following guidelines are recommended.

- ◆ Dedicated V_{DD} and GND planes.
- ◆ The device must be isolated from system power supply noise. A 0.1µF and a 2.2 µF decoupling capacitor should be mounted on the component side of the board as close to the VDD pin as possible. No vias should be used between the decoupling capacitor and VDD pin. The PCB trace to VDD pin and the ground via should be kept as short as possible. All the VDD pins should have decoupling capacitors.
- ◆ In an optimum layout all components are on the same side of the board, minimizing vias through other signal layers.

P3MS650103H

A typical layout is shown in the figure below.

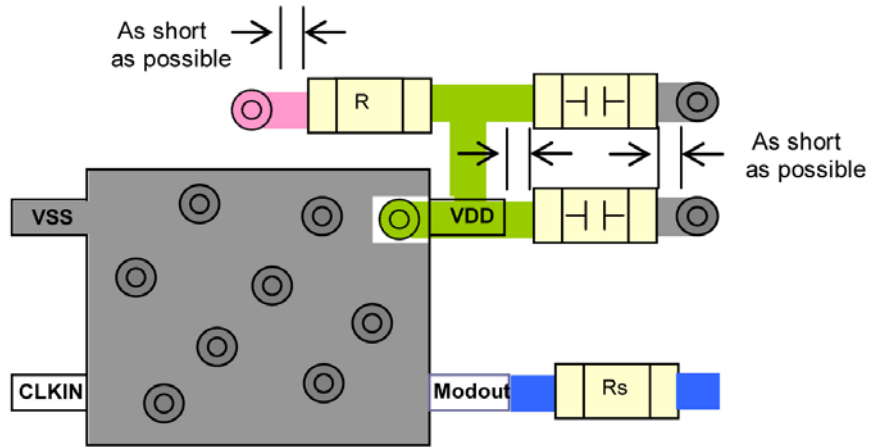

Figure 5. Recommended PCB Layout

ORDERING INFORMATION

Ordering Code	Marking	Temperature	Package Type	Shipping [†]
P3MS650103H-4CR	B	-20°C to +85°C	4-pin (1.2 mm x 1.0 mm) WDFN (Pb-Free)	3000 / Tape & Reel

[†]For information on tape and reel specifications, including part orientation and tape sizes, please refer to our Tape and Reel Packaging Specifications Brochure, BRD8011/D.

*A "microdot" placed at the end of last row of marking or just below the last row toward the center of package indicates Pb-Free.

P3MS650103H

PACKAGE DIMENSIONS

WDFN4, 1.0x1.2, 0.5P
CASE 511BS-01
ISSUE O

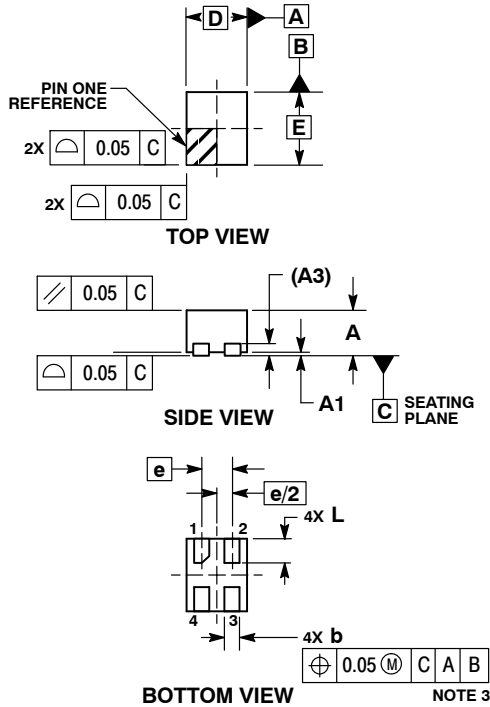

NOTES:

1. DIMENSIONING AND TOLERANCING PER ASME Y14.5M, 1994.
2. CONTROLLING DIMENSION: MILLIMETERS.
3. DIMENSION b APPLIES TO PLATED TERMINAL AND IS MEASURED BETWEEN 0.15 AND 0.20 mm FROM THE TERMINAL TIPS.
4. PACKAGE DIMENSIONS EXCLUSIVE OF BURRS AND MOLD FLASH.

MILLIMETERS		
DIM	MIN	MAX
A	0.70	0.80
A1	0.00	0.05
A3	0.20 REF	
b	0.20	0.30
D	1.00 BSC	
E	1.20 BSC	
e	0.50 BSC	
L	0.35	0.45

RECOMMENDED MOUNTING FOOTPRINT*

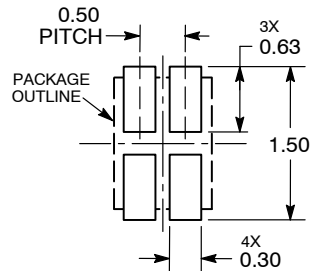

*For additional information on our Pb-Free strategy and soldering details, please download the ON Semiconductor Soldering and Mounting Techniques Reference Manual, SOLDERRM/D.

ON Semiconductor and are registered trademarks of Semiconductor Components Industries, LLC (SCILLC). SCILLC reserves the right to make changes without further notice to any products herein. SCILLC makes no warranty, representation or guarantee regarding the suitability of its products for any particular purpose, nor does SCILLC assume any liability arising out of the application or use of any product or circuit, and specifically disclaims any and all liability, including without limitation special, consequential or incidental damages. "Typical" parameters which may be provided in SCILLC data sheets and/or specifications can and do vary in different applications and actual performance may vary over time. All operating parameters, including "Typicals" must be validated for each customer application by customer's technical experts. SCILLC does not convey any license under its patent rights nor the rights of others. SCILLC products are not designed, intended, or authorized for use as components in systems intended for surgical implant into the body, or other applications intended to support or sustain life, or for any other application in which the failure of the SCILLC product could create a situation where personal injury or death may occur. Should Buyer purchase or use SCILLC products for any such unintended or unauthorized application, Buyer shall indemnify and hold SCILLC and its officers, employees, subsidiaries, affiliates, and distributors harmless against all claims, costs, damages, and expenses, and reasonable attorney fees arising out of, directly or indirectly, any claim of personal injury or death associated with such unintended or unauthorized use, even if such claim alleges that SCILLC was negligent regarding the design or manufacture of the part. SCILLC is an Equal Opportunity/Affirmative Action Employer. This literature is subject to all applicable copyright laws and is not for resale in any manner.

PUBLICATION ORDERING INFORMATION

LITERATURE FULFILLMENT:
Literature Distribution Center for ON Semiconductor
P.O. Box 5163, Denver, Colorado 80217 USA
Phone: 303-675-2175 or 800-344-3860 Toll Free USA/Canada
Fax: 303-675-2176 or 800-344-3867 Toll Free USA/Canada
Email: orderlit@onsemi.com

N. American Technical Support: 800-282-9855 Toll Free
USA/Canada
Europe, Middle East and Africa Technical Support:
Phone: 421 33 790 2910
Japan Customer Focus Center
Phone: 81-3-5773-3850

ON Semiconductor Website: www.onsemi.com
Order Literature: <http://www.onsemi.com/orderlit>
For additional information, please contact your local Sales Representative

X-ON Electronics

Largest Supplier of Electrical and Electronic Components

Click to view similar products for [Clock Generators & Support Products](#) category:

Click to view products by [ON Semiconductor](#) manufacturer:

Other Similar products are found below :

[CV183-2TPAG](#) [950810CGLF](#) [9DBV0741AKILF](#) [9VRS4420DKLF](#) [CY25404ZXI226](#) [CY25422SXI-004](#) [MPC9893AE](#) [NB3H5150-01MNTXG](#) [PL602-20-K52TC](#) [PI6LC48P0101LIE](#) [82P33814ANLG](#) [840021AGLF](#) [ZL30244LFG7](#) [PI6LC48C21LE](#) [ZL30245LFG7](#) [PI6LC48P0405LIE](#) [PI6LC48P03LE](#) [MAX24505EXG+](#) [ZL30163GDG2](#) [5L1503L-000NVTG8](#) [ZL30673LFG7](#) [MAX24188ETK2](#) [ZL30152GGG2](#) [5L1503-000NVTG8](#) [PI6C557-01BZHIEX](#) [PI6LC48C21LIE](#) [CY2542QC002](#) [5P35023-106NLGI](#) [5X1503L-000NLGI8](#) [ZL30121GGG2V2](#) [ZL30282LDG1](#) [ZL30102QDG1](#) [ZL30159GGG2](#) [DS1070K](#) [ZL30145GGG2](#) [ZL30312GKG2](#) [MAX24405EXG2](#) [ZL30237GGG2](#) [SY100EL34LZG](#) [9FGV1002BQ506LTGI](#) [AD9518-4ABCPZ](#) [MX852BB0030](#) [PI6LC4840ZHE](#) [AD9516-0BCPZ-REEL7](#) [AD9574BCPZ-REEL7](#) [PL602-21TC-R](#) [ZL30105QDG1](#) [ZL30100QDG1](#) [ZL30142GGG2](#) [ZL30250LDG1](#)