

# RFD16N05LSM

## Product Preview

### **MOSFET** - Power, N-Channel, Logic Level 50 V, 16 A, 47 m $\Omega$

These are N-Channel logic level power MOSFETs manufactured using the MegaFET process. This process, which uses feature sizes approaching those of LSI integrated circuits gives optimum utilization of silicon, resulting in outstanding performance. They were designed for use with logic level (5 V) driving sources in applications such as programmable controllers, switching regulators, switching converters, motor relay drivers and emitter switches for bipolar transistors. This performance is accomplished through a special gate oxide design which provides full rated conductance at gate biases in the 3 V to 5 V range, thereby facilitating true on-off power control directly from logic circuit supply voltages.

Formerly developmental type TA09871.

#### Features

- 16 A, 50 V
- $I_{DS(ON)} = 0.047 \Omega$
- UIS SOA Rating Curve (Single Pulse)
- Design Optimized for 5 V Gate Drives
- Can be Driven Directly from CMOS, NMOS, TTL Circuits
- SOA is Power Dissipation Limited
- Nanosecond Switching Speeds
- Linear Transfer Characteristics
- High Input Impedance
- Majority Carrier Device
- Related Literature
  - ◆ TB334 "Guidelines for Soldering Surface Mount Components to PC Boards"



ON Semiconductor®

[www.onsemi.com](http://www.onsemi.com)

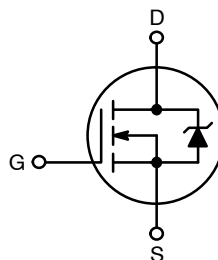

DPAK  
TO-252  
CASE 369AS

#### MARKING DIAGRAM

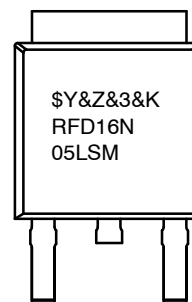

&Y = ON Semiconductor Logo  
&Z = Assembly Plant Code  
&3 = Numeric Date Code  
&K = Lot Code  
RFD16N05LSM = Specific Device Code

#### ORDERING INFORMATION

Part Number	Package	Brand
RFD16N05LSM9A	TO-252AA	RFD16N05LSM

# RFD16N05LSM

## MAXIMUM RATINGS

Rating	Symbol	RFD16N05LSM9A	Units
Drain to Source Voltage (Note 1)	$V_{DS}$	50	V
Drain to Gate Voltage ( $R_{GS}$ 20 k $\Omega$ ) (Note 1)	$V_{DGR}$	50	V
Continuous Drain Current	$I_D$	16	A
Pulsed Drain Current (Note 3)	$I_{DM}$	45	A
Gate to Source Voltage	$V_{GS}$	$\pm 10$	V
Maximum Power Dissipation	$P_D$	60	W
Derate Above 25°C		0.48	W/°C
Operating and Storage Temperature	$T_J, T_{STG}$	-55 to 150	°C
Maximum Temperature for Soldering			
Leads at 0.063 in (1.6 mm) from Case for 10 s	$T_L$	300	°C
Package Body for 10 s, See Techbrief 334	$T_{pkg}$	260	°C

Stresses exceeding those listed in the Maximum Ratings table may damage the device. If any of these limits are exceeded, device functionality should not be assumed, damage may occur and reliability may be affected.

1.  $T_J = 25^\circ\text{C}$  to  $125^\circ\text{C}$ .

## ELECTRICAL SPECIFICATIONS ( $T_C = 25^\circ\text{C}$ unless otherwise specified)

PARAMETER	SYMBOL	TEST CONDITIONS	MIN	TYP	MAX	UNITS
Drain to Source Breakdown Voltage	$BV_{DSS}$	$I_D = 250$ mA, $V_{GS} = 0$ V, Figure 10	50	-	-	V
Gate to Threshold Voltage	$V_{GS(TH)}$	$V_{GS} = V_{DS}$ , $I_D = 250$ $\mu\text{A}$ , Figure 9	1	-	2	V
Zero Gate Voltage Drain Current	$I_{DSS}$	$V_{DS} = 40$ V, $V_{GS} = 0$ V	-	-	1	$\mu\text{A}$
		$T_C = 150^\circ\text{C}$	-	-	50	$\mu\text{A}$
Gate to Source Leakage Current	$I_{GSS}$	$V_{GS} = \pm 10$ V, $V_{DS} = 0$ V	-	-	100	nA
Drain to Source On Resistance (Note 2)	$r_{DS(ON)}$	$I_D = 16$ A, $V_{GS} = 5$ V	-	-	0.047	$\Omega$
		$I_D = 16$ A, $V_{GS} = 4$ V	-	-	0.056	$\Omega$
Turn-On Time	$t_{(ON)}$	$V_{DD} = 25$ V, $I_D = 8$ A, $V_{GS} = 5$ V, $R_{GS} = 12.5$ $\Omega$ Figures 15, 16	-	-	60	ns
Turn-On Delay Time	$t_{d(ON)}$		-	14	-	ns
Rise Time	$t_r$		-	30	-	ns
Turn-Off Delay Time	$t_{d(OFF)}$		-	42	-	ns
Fall Time	$t_f$		-	14	-	ns
Turn-Off Time	$t_{(OFF)}$		-	-	-	ns
Total Gate Charge	$Q_g(TOT)$		$V_{GS} = 0$ V to 10 V	-	-	80
Gate Charge at 5 V	$Q_{g(5)}$	$V_{GS} = 0$ V to 5 V				
Threshold Gate Charge	$Q_{g(TH)}$	$V_{GS} = 0$ V to 1 V				
Thermal Resistance Junction to Case	$R_{\theta JC}$		-	-	2.083	°C/W
Thermal Resistance Junction to Ambient	$R_{\theta JA}$		-	-	100	°C/W

## SOURCE TO DRAIN DIODE SPECIFICATIONS

PARAMETER	SYMBOL	TEST CONDITIONS	MIN	TYP	MAX	UNITS
Source to Drain Diode Voltage	$V_{SD}$	$I_{SD} = 16$ A	-	-	1.5	V
Diode Reverse Recovery Time	$t_{rr}$	$I_{SD} = 16$ A, $dI_{SD}/dt = 100$ A/ $\mu\text{s}$	-	-	125	ns

2. Pulse Test: Pulse Width  $\leq 300$  ms, Duty Cycle  $\leq 2\%$ .

3. Repetitive Rating: Pulse Width limited by max junction temperature.

# RFD16N05LSM

## TYPICAL PERFORMANCE CURVES (Unless Otherwise Specified)

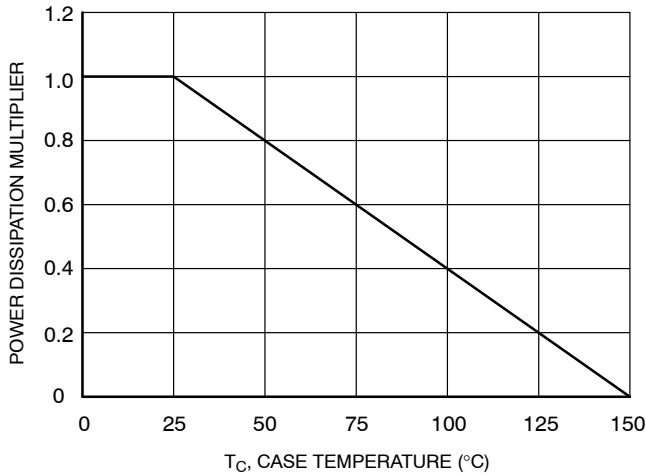

**Figure 1. Normalized Power Dissipation vs Case Temperature**

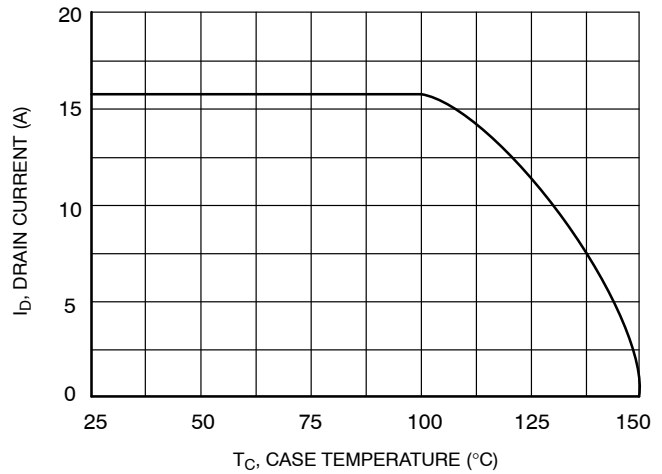

**Figure 2. Maximum Continuous Drain Current vs Case Temperature**

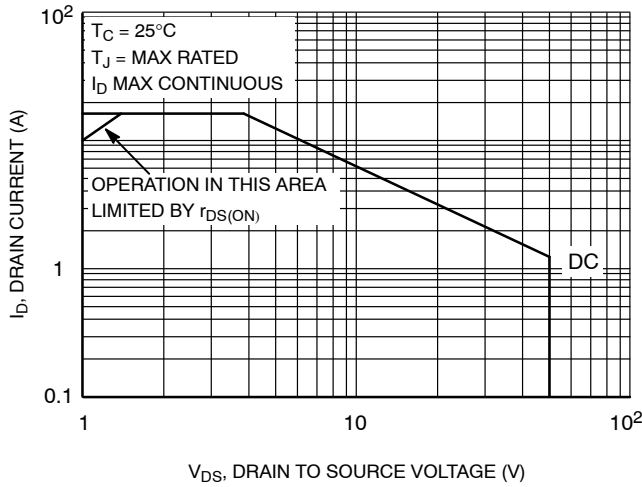

**Figure 3. Forward Bias Safe Operating Area**

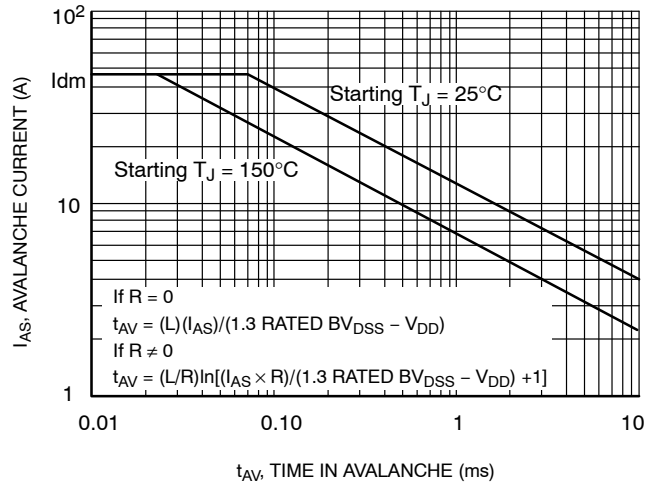

**Figure 4. Unclamped Inductive Switching SOA (Single Pulse UIS SOA)**

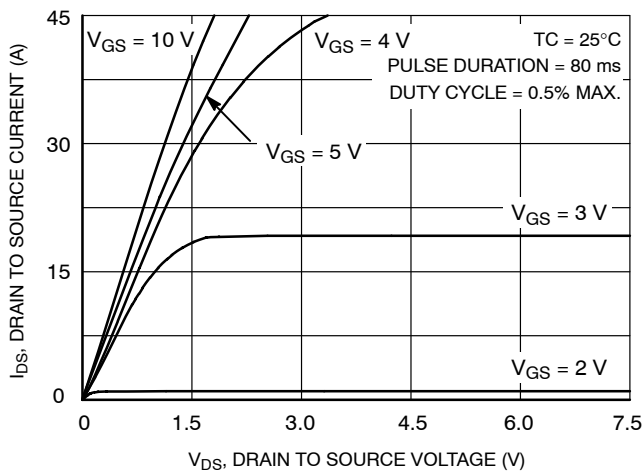

**Figure 5. Saturation Characteristics**

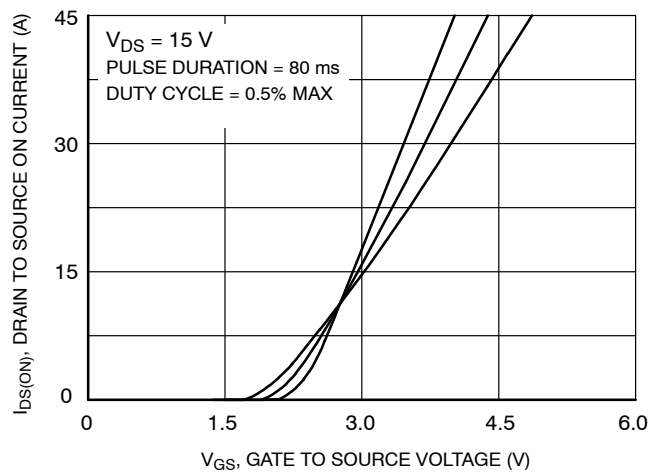

**Figure 6. Transfer Characteristics**

TYPICAL PERFORMANCE CURVES (Unless Otherwise Specified) (continued)

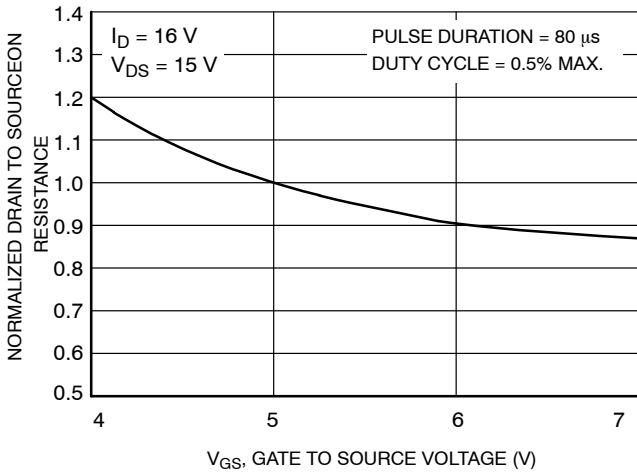

Figure 7. Drain to Source on Resistance vs Gate Voltage and Drain Current

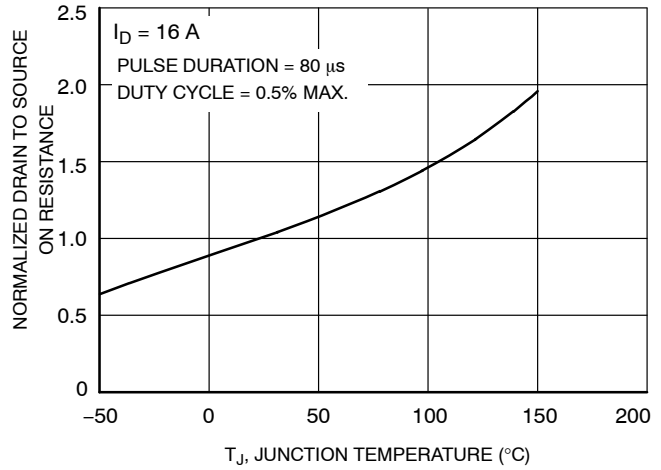

Figure 8. Normalized Drain to Source on Resistance vs. Junction Temperature

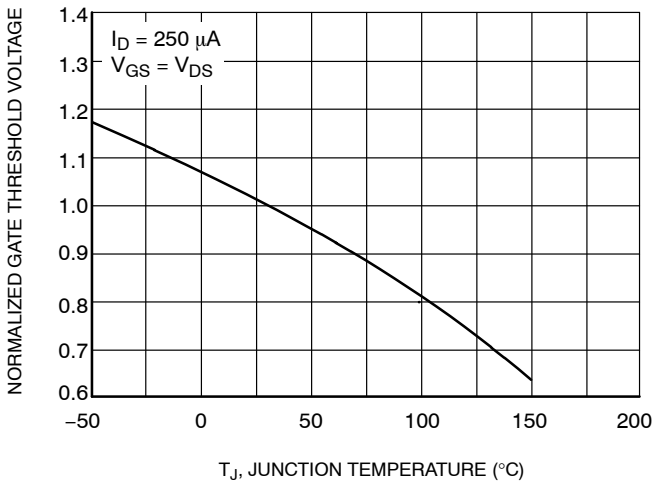

Figure 9. Normalized Gate Threshold vs Junction Temperature

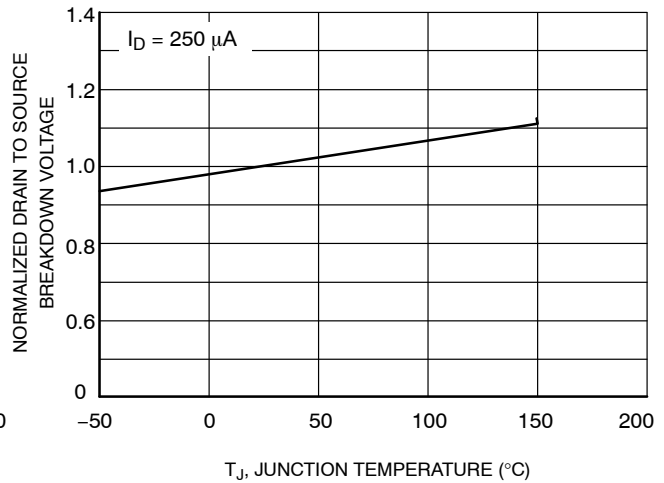

Figure 10. Normalized Drain to Source Breakdown Voltage vs Junction Temperature

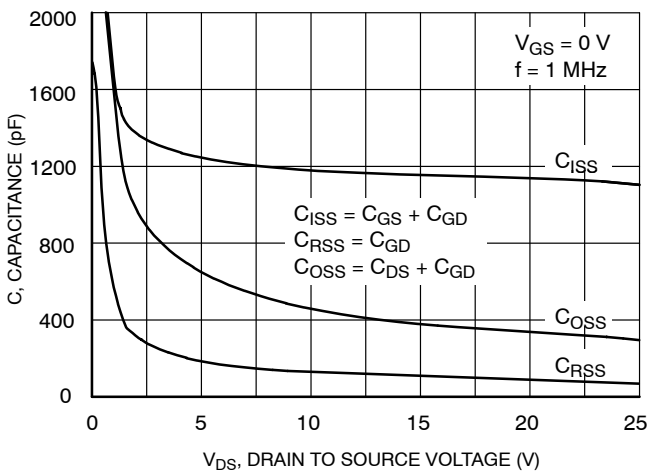

Figure 11. Capacitance vs Drain to Source Voltage

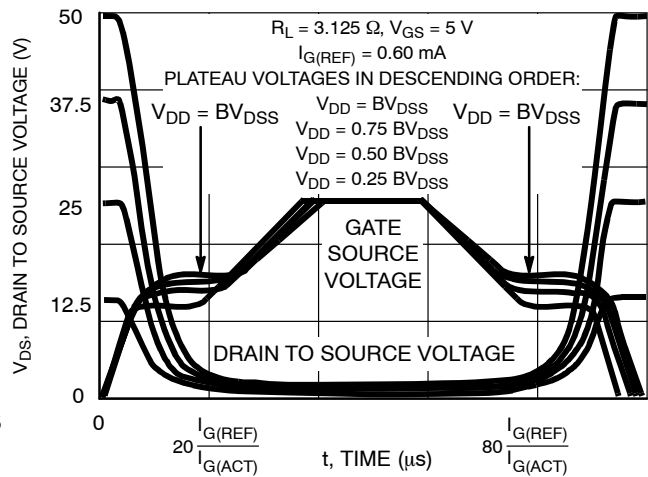

Figure 12. Normalized Switching Waveforms for Constant Gate Current

TEST CIRCUITS AND WAVEFORMS

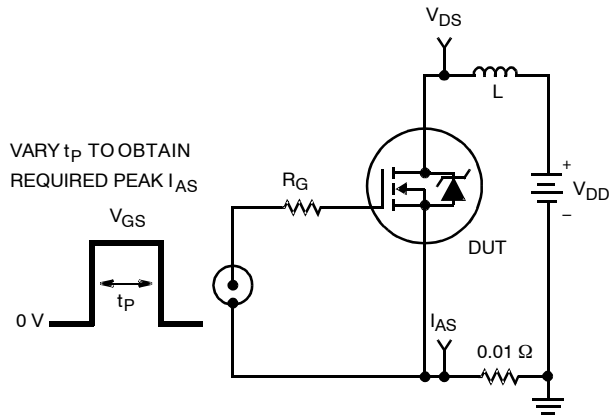

Figure 13. Unclamped Energy Test Circuit

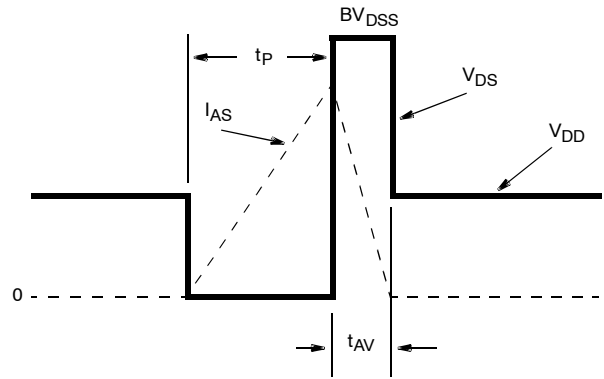

Figure 14. Unclamped Energy Waveforms

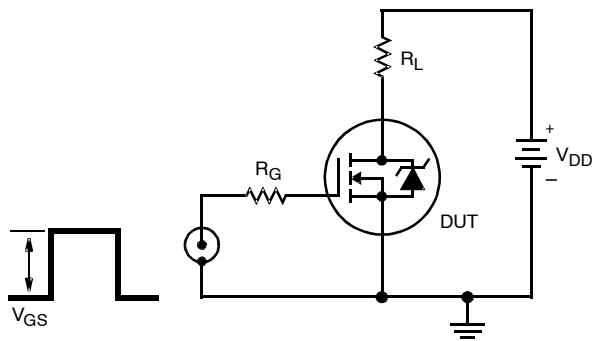

Figure 15. Switching Time Test Circuit

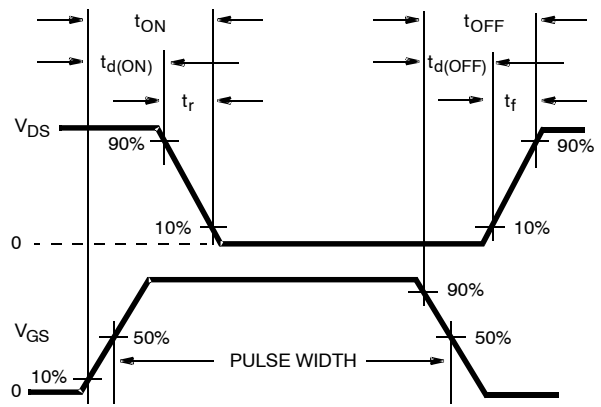

Figure 16. Resistive Switching Waveforms

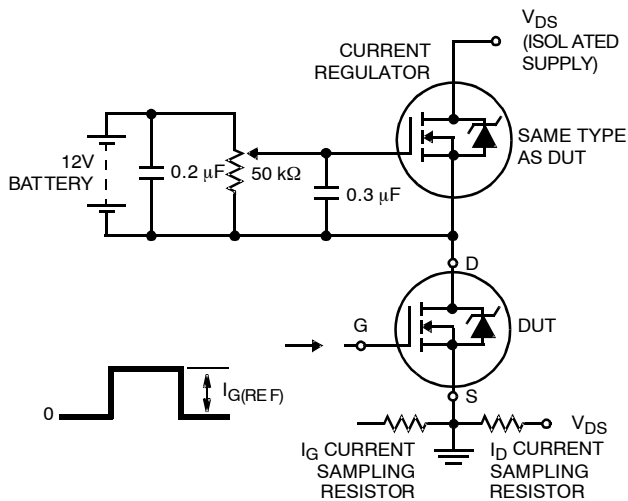

Figure 17. Gate Charge Test Circuit

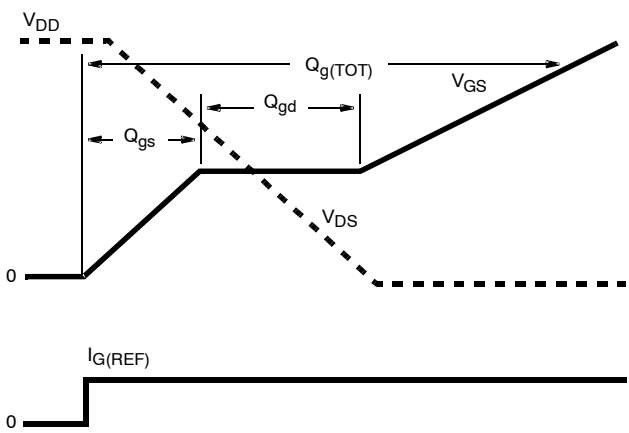

Figure 18. Gate Charge Waveforms

# RFD16N05LSM

## PSPICE ELECTRICAL MODEL

```
.SUBCKT RFD16N05L 2 1 3 ; REV 4/8/92

Ca 12 8 3.33e-9
Cb 15 14 3.11e-9
Cin 6 8 1.21e-9

Dbody 7 5 DBDMOD
Dbreak 5 11 DBKMOD
Dplcap 10 5 DPLCAPMOD

Ebreak 11 7 17 18 70.9
Eds 14 8 5 8 1
Egs 13 8 6 8 1
Esg 6 10 6 8 1
Evto 20 6 18 8 1

IT 8 17 1

Lgate 1 9 1.38e-9
Ldrain 2 5 1.0e-12
Lsource 3 7 1.0e-9

Mos1 16 6 8 8 MOSMOD M = 0.99
Mos2 16 21 8 8 MOSMOD M = 0.01

Rin 6 8 1e9
Rbreak 17 18 RBKMOD 1
Rdrain 5 16 RDSMOD 27.38e-3
Rgate 9 20 2.98
Rsource 8 7 RDSMOD 0.614e-3
Rvto 18 19 RVTOMOD 1

S1a 6 12 13 8 S1AMOD
S1b 13 12 13 8 S1BMOD
S2a 6 15 14 13 S2AMOD
S2b 13 15 14 13 S2BMOD

Vbat 8 19 DC 1
Vto 21 6 0.448

.MODEL DBDMOD D (IS = 1.34e-13 RS = 1.21e-2 TRS1 = 1.64e-3 TRS2 = 2.59e-6 +CJO = 1.13e-9
TT = 4.14e-8)
.MODEL DBKMOD D (RS = 8.82e-2 TRS1 = -2.01e-3 TRS2 = 7.32e-10)
.MODEL DPLCAPMOD D (CJO = 0.522e-9 IS = 1e-30 N = 10)
.MODEL MOSMOD NMOS (VTO = 2.054 KP = 24.73 IS = 1e-30 N = 10 TOX = 1 L = 1u W = 1u)
.MODEL RBKMOD RES (TC1 = 1.01e-3 TC2 = 5.21e-8)
.MODEL RDSMOD RES (TC1 = 3.66e-3 TC2 = 1.46e-5)
.MODEL RVTOMOD RES (TC1 = -1.81e-3 TC2 = 1.41e-6)
.MODEL S1AMOD VSWITCH (RON = 1e-5 ROFF = 0.1 VON = -4.25 VOFF = -2.25)
.MODEL S1BMOD VSWITCH (RON = 1e-5 ROFF = 0.1 VON = -2.25 VOFF = -4.25)
.MODEL S2AMOD VSWITCH (RON = 1e-5 ROFF = 0.1 VON = -0.65 VOFF = 4.35)
.MODEL S2BMOD VSWITCH (RON = 1e-5 ROFF = 0.1 VON = 4.35 VOFF = -0.65)

.ENDS
```

NOTE: For further discussion of the PSPICE model, consult *A New PSPICE Sub-Circuit for the Power MOSFET Featuring Global Temperature Options*; written by William J. Hepp and C. Frank Wheatley.

# RFD16N05LSM

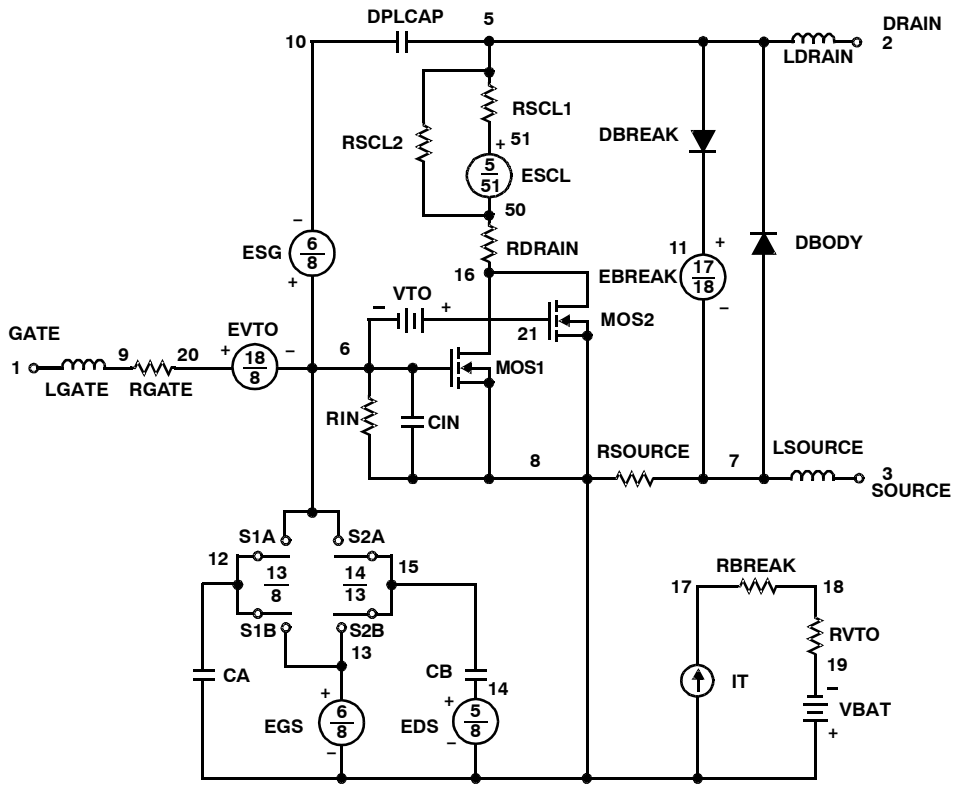

Figure 19.

# MECHANICAL CASE OUTLINE

## PACKAGE DIMENSIONS

ON Semiconductor®



### DPAK3 (TO-252 3 LD)

#### CASE 369AS

#### ISSUE O

DATE 30 SEP 2016

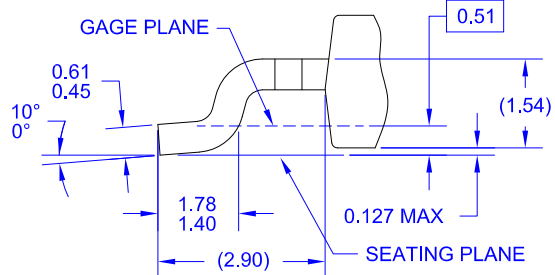
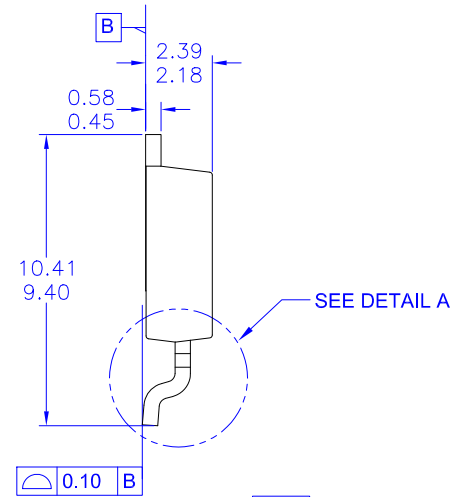
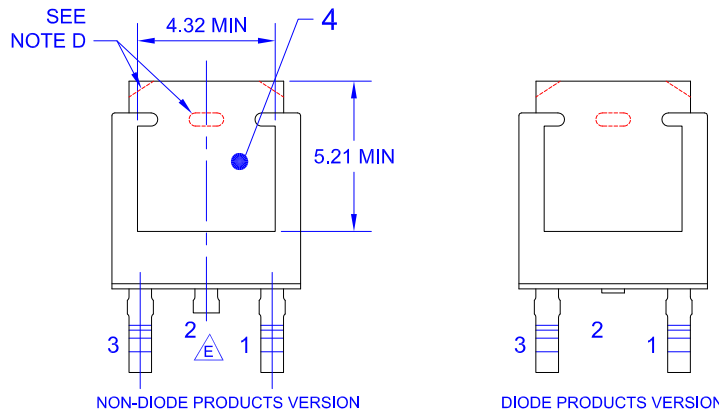
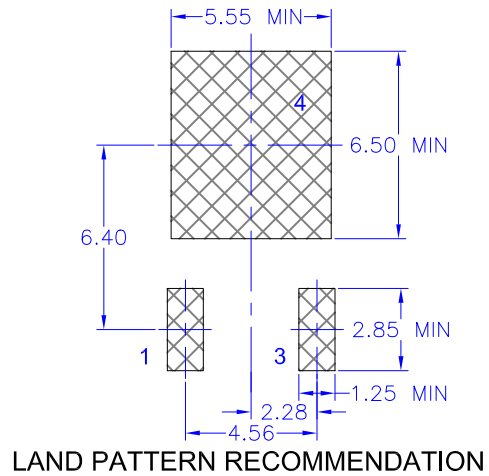
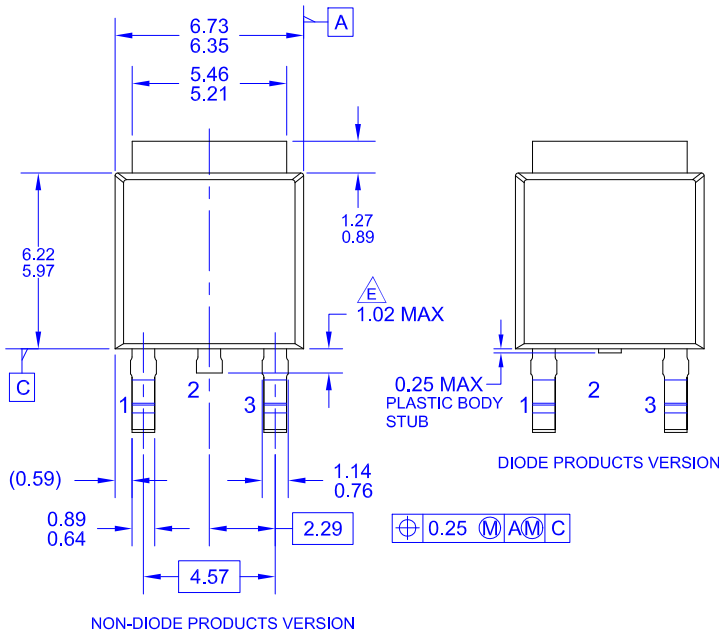

- NOTES: UNLESS OTHERWISE SPECIFIED
- A) THIS PACKAGE CONFORMS TO JEDEC, TO-252, ISSUE C, VARIATION AA.
  - B) ALL DIMENSIONS ARE IN MILLIMETERS.
  - C) DIMENSIONING AND TOLERANCING PER ASME Y14.5M-2009.
  - D) SUPPLIER DEPENDENT MOLD LOCKING HOLES OR CHAMFERED CORNERS OR EDGE PROTRUSION.
  - E) TRIMMED CENTER LEAD IS PRESENT ONLY FOR DIODE PRODUCTS
  - F) DIMENSIONS ARE EXCLUSIVE OF BURRS, MOLD FLASH AND TIE BAR EXTRUSIONS.
  - G) LAND PATTERN RECOMMENDATION IS BASED ON IPC7351A STD TO228P991X239-3N.

<b>DOCUMENT NUMBER:</b>	<b>98AON13810G</b>	Electronic versions are uncontrolled except when accessed directly from the Document Repository. Printed versions are uncontrolled except when stamped "CONTROLLED COPY" in red.
<b>DESCRIPTION:</b>	<b>DPAK3 (TO-252 3 LD)</b>	<b>PAGE 1 OF 1</b>

ON Semiconductor and are trademarks of Semiconductor Components Industries, LLC dba ON Semiconductor or its subsidiaries in the United States and/or other countries. ON Semiconductor reserves the right to make changes without further notice to any products herein. ON Semiconductor makes no warranty, representation or guarantee regarding the suitability of its products for any particular purpose, nor does ON Semiconductor assume any liability arising out of the application or use of any product or circuit, and specifically disclaims any and all liability, including without limitation special, consequential or incidental damages. ON Semiconductor does not convey any license under its patent rights nor the rights of others.



**onsemi**, **Onsemi**, and other names, marks, and brands are registered and/or common law trademarks of Semiconductor Components Industries, LLC dba "**onsemi**" or its affiliates and/or subsidiaries in the United States and/or other countries. **onsemi** owns the rights to a number of patents, trademarks, copyrights, trade secrets, and other intellectual property. A listing of **onsemi**'s product/patent coverage may be accessed at [www.onsemi.com/site/pdf/Patent-Marking.pdf](http://www.onsemi.com/site/pdf/Patent-Marking.pdf). **onsemi** reserves the right to make changes at any time to any products or information herein, without notice. The information herein is provided "as-is" and **onsemi** makes no warranty, representation or guarantee regarding the accuracy of the information, product features, availability, functionality, or suitability of its products for any particular purpose, nor does **onsemi** assume any liability arising out of the application or use of any product or circuit, and specifically disclaims any and all liability, including without limitation special, consequential or incidental damages. Buyer is responsible for its products and applications using **onsemi** products, including compliance with all laws, regulations and safety requirements or standards, regardless of any support or applications information provided by **onsemi**. "Typical" parameters which may be provided in **onsemi** data sheets and/or specifications can and do vary in different applications and actual performance may vary over time. All operating parameters, including "Typicals" must be validated for each customer application by customer's technical experts. **onsemi** does not convey any license under any of its intellectual property rights nor the rights of others. **onsemi** products are not designed, intended, or authorized for use as a critical component in life support systems or any FDA Class 3 medical devices or medical devices with a same or similar classification in a foreign jurisdiction or any devices intended for implantation in the human body. Should Buyer purchase or use **onsemi** products for any such unintended or unauthorized application, Buyer shall indemnify and hold **onsemi** and its officers, employees, subsidiaries, affiliates, and distributors harmless against all claims, costs, damages, and expenses, and reasonable attorney fees arising out of, directly or indirectly, any claim of personal injury or death associated with such unintended or unauthorized use, even if such claim alleges that **onsemi** was negligent regarding the design or manufacture of the part. **onsemi** is an Equal Opportunity/Affirmative Action Employer. This literature is subject to all applicable copyright laws and is not for resale in any manner.

## PUBLICATION ORDERING INFORMATION

### LITERATURE FULFILLMENT:

Email Requests to: [orderlit@onsemi.com](mailto:orderlit@onsemi.com)

**onsemi Website:** [www.onsemi.com](http://www.onsemi.com)

### TECHNICAL SUPPORT

**North American Technical Support:**

Voice Mail: 1 800-282-9855 Toll Free USA/Canada

Phone: 011 421 33 790 2910

**Europe, Middle East and Africa Technical Support:**

Phone: 00421 33 790 2910

For additional information, please contact your local Sales Representative

## X-ON Electronics

Largest Supplier of Electrical and Electronic Components

*Click to view similar products for [MOSFET](#) category:*

*Click to view products by [ON Semiconductor](#) manufacturer:*

Other Similar products are found below :

[614233C](#) [648584F](#) [IRFD120](#) [JANTX2N5237](#) [FCA20N60\\_F109](#) [FDZ595PZ](#) [2SK2545\(Q,T\)](#) [405094E](#) [423220D](#) [TPCC8103,L1Q\(CM](#)  
[MIC4420CM-TR](#) [VN1206L](#) [SBVS138LT1G](#) [614234A](#) [715780A](#) [NTNS3166NZT5G](#) [SSM6J414TU,LF\(T](#) [751625C](#) [BUK954R8-60E](#)  
[NTE6400](#) [SQJ402EP-T1-GE3](#) [2SK2614\(TE16L1,Q\)](#) [2N7002KW-FAI](#) [DMN1017UCP3-7](#) [EFC2J004NUZTDG](#) [ECH8691-TL-W](#)  
[FCAB21350L1](#) [P85W28HP2F-7071](#) [DMN1053UCP4-7](#) [NTE221](#) [NTE222](#) [NTE2384](#) [NTE2903](#) [NTE2941](#) [NTE2945](#) [NTE2946](#) [NTE2960](#)  
[NTE2967](#) [NTE2969](#) [NTE2976](#) [NTE455](#) [NTE6400A](#) [NTE2910](#) [NTE2916](#) [NTE2956](#) [NTE2911](#) [DMN2080UCB4-7](#) [TK10A80W,S4X\(S](#)  
[SSM6P69NU,LF](#) [DMP22D4UFO-7B](#)