

Operational Amplifiers, Dual Power, 1.0 A Output Current

TCA0372, TCA0372B, NCV0372B

The TCA0372 is a monolithic circuit intended for use as a power operational amplifier in a wide range of applications, including servo amplifiers and power supplies. No deadband crossover distortion provides better performance for driving coils.

Features

- Output Current to 1.0 A
- Slew Rate of 1.3 V/ μ s
- Wide Bandwidth of 1.1 MHz
- Internal Thermal Shutdown
- Single or Split Supply Operation
- Excellent Gain and Phase Margins
- Common Mode Input Includes Ground
- Zero Deadband Crossover Distortion
- NCV devices are AEC-Q100 Qualified and PPAP Capable
- These Devices are Pb-Free, Halogen Free/BFR Free and are RoHS Compliant

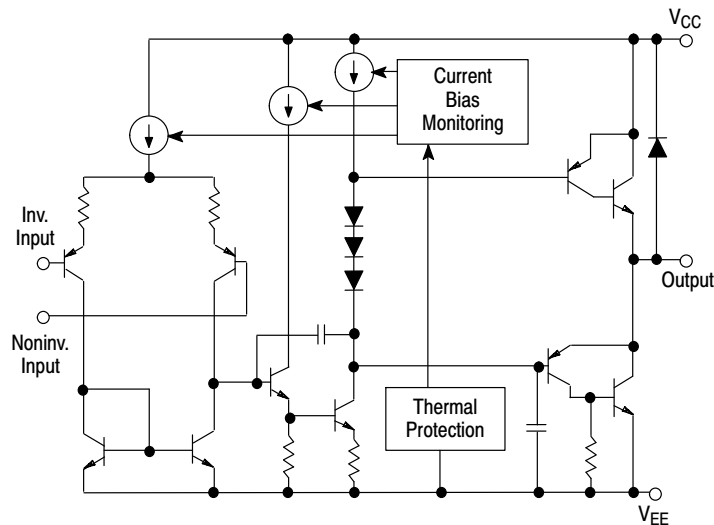
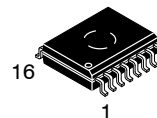

Figure 1. Representative Block Diagram



ON Semiconductor®

www.onsemi.com



SOIC-16W
DW SUFFIX
CASE 751G

MARKING DIAGRAMS

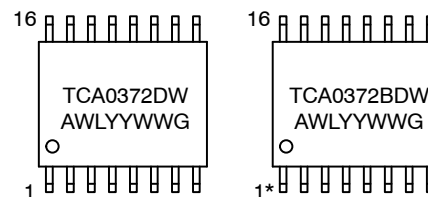

*Also applies to NCV0372BDWR2G.

A = Assembly Location
WL = Wafer Lot
YY = Year
WW = Work Week
G = Pb-Free Package

PIN CONNECTIONS

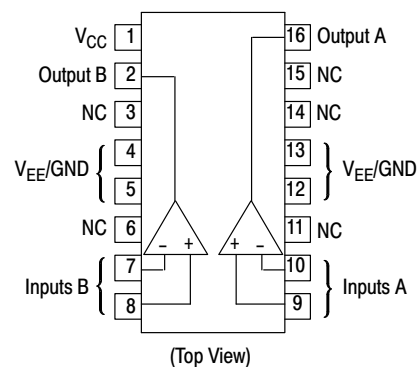

ORDERING INFORMATION

See detailed ordering and shipping information in the package dimensions section on page 5 of this data sheet.

TCA0372, TCA0372B, NCV0372B

MAXIMUM RATINGS

Rating	Symbol	Value	Unit
Supply Voltage (from V_{CC} to V_{EE})	V_S	40	V
Input Differential Voltage Range	V_{IDR}	Note 1	V
Input Voltage Range	V_{IR}	Note 1	V
Junction Temperature (Note 2)	T_J	+150	°C
Operating Temperature Range	T_A	-40 to +125	°C
Storage Temperature Range	T_{stg}	-55 to +150	°C
DC Output Current	I_O	1.0	A
Peak Output Current (Nonrepetitive)	$I_{(max)}$	1.5	A
Thermal Resistance, Junction-to-Air	$R_{\theta JA}$	80	°C/W
Thermal Resistance, Junction-to-Case	$R_{\theta JC}$	12	°C/W

Stresses exceeding those listed in the Maximum Ratings table may damage the device. If any of these limits are exceeded, device functionality should not be assumed, damage may occur and reliability may be affected.

1. Either or both input voltages should not exceed the magnitude of V_{CC} or V_{EE} .
2. Power dissipation must be considered to ensure maximum junction temperature (T_J) is not exceeded.

TCA0372, TCA0372B, NCV0372B

DC ELECTRICAL CHARACTERISTICS ($V_{CC} = +15\text{ V}$, $V_{EE} = -15\text{ V}$, R_L connected to ground, $T_A = -40^\circ$ to $+125^\circ\text{C}$.)

Characteristics	Symbol	Min	Typ	Max	Unit
Input Offset Voltage ($V_{CM} = 0$) $T_A = +25^\circ\text{C}$ T_A, T_{low} to T_{high}	V_{IO}	–	1.0	15 20	mV
Average Temperature Coefficient of Offset Voltage	$\Delta V_{IO}/\Delta T$	–	20	–	$\mu\text{V}/^\circ\text{C}$
Input Bias Current ($V_{CM} = 0$)	I_{IB}	–	100	500	nA
Input Offset Current ($V_{CM} = 0$)	I_{IO}	–	10	50	nA
Large Signal Voltage Gain $V_O = \pm 10\text{ V}$, $R_L = 2.0\text{ k}$	A_{VOL}	30	100	–	V/mV
Output Voltage Swing ($I_L = 100\text{ mA}$) $T_A = +25^\circ\text{C}$ $T_A = T_{low}$ to T_{high} $T_A = +25^\circ\text{C}$ $T_A = T_{low}$ to T_{high}	V_{OH} V_{OL}	14.0 13.9	14.2 –	– – –14.0 –13.9	V
Output Voltage Swing ($I_L = 1.0\text{ A}$) $V_{CC} = +24\text{ V}$, $V_{EE} = 0\text{ V}$, $T_A = +25^\circ\text{C}$ $V_{CC} = +24\text{ V}$, $V_{EE} = 0\text{ V}$, $T_A = T_{low}$ to T_{high} $V_{CC} = +24\text{ V}$, $V_{EE} = 0\text{ V}$, $T_A = +25^\circ\text{C}$ $V_{CC} = +24\text{ V}$, $V_{EE} = 0\text{ V}$, $T_A = T_{low}$ to T_{high}	V_{OH} V_{OL}	22.5 22.5	22.7 –	– – 1.5 1.6	V
Input Common Mode Voltage Range $T_A = +25^\circ\text{C}$ $T_A = T_{low}$ to T_{high}	V_{ICR}	V_{EE} to $(V_{CC} - 1.0)$ V_{EE} to $(V_{CC} - 1.3)$			V
Common Mode Rejection Ratio ($R_S = 10\text{ k}$)	CMRR	70	90	–	dB
Power Supply Rejection Ratio ($R_S = 100\ \Omega$)	PSRR	70	90	–	dB
Power Supply Current $T_A = +25^\circ\text{C}$ $T_A = T_{low}$ to T_{high}	I_D	–	5.0 8.0 – –	10 10 14 14	mA
					TCA0372 TCA0372B/NCV0372B TCA0372 TCA0372B/NCV0372B

AC ELECTRICAL CHARACTERISTICS ($V_{CC} = +15\text{ V}$, $V_{EE} = -15\text{ V}$, R_L connected to ground, $T_A = +25^\circ\text{C}$, unless otherwise noted.)

Characteristics	Symbol	Min	Typ	Max	Unit
Slew Rate ($V_{in} = -10\text{ V}$ to $+10\text{ V}$, $R_L = 2.0\text{ k}$, $C_L = 100\text{ pF}$) $A_V = -1.0$, $T_A = T_{low}$ to T_{high}	SR	1.0	1.4	–	V/ μs
Gain Bandwidth Product ($f = 100\text{ kHz}$, $C_L = 100\text{ pF}$, $R_L = 2.0\text{ k}$) $T_A = 25^\circ\text{C}$ $T_A = T_{low}$ to T_{high}	GBW	0.9 0.7	1.4 –	– –	MHz
Phase Margin $T_J = T_{low}$ to T_{high} $R_L = 2.0\text{ k}$, $C_L = 100\text{ pF}$	ϕ_m	–	65	–	Degrees
Gain Margin $R_L = 2.0\text{ k}$, $C_L = 100\text{ pF}$	A_m	–	15	–	dB
Equivalent Input Noise Voltage $R_S = 100\ \Omega$, $f = 1.0$ to 100 kHz	e_n	–	22	–	nV/ $\sqrt{\text{Hz}}$
Total Harmonic Distortion $A_V = -1.0$, $R_L = 50\ \Omega$, $V_O = 0.5\text{ VRMS}$, $f = 1.0\text{ kHz}$	THD	–	0.02	–	%

NOTE: In case V_{EE} is disconnected before V_{CC} , a diode between V_{EE} and Ground is recommended to avoid damaging the device.

TCA0372, TCA0372B, NCV0372B

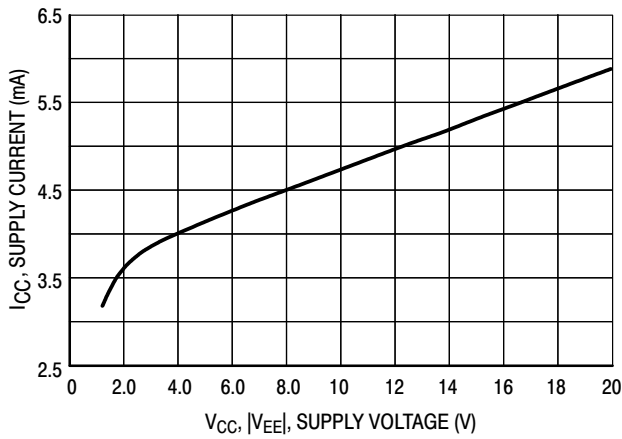

Figure 2. Supply Current versus Supply Voltage with No Load

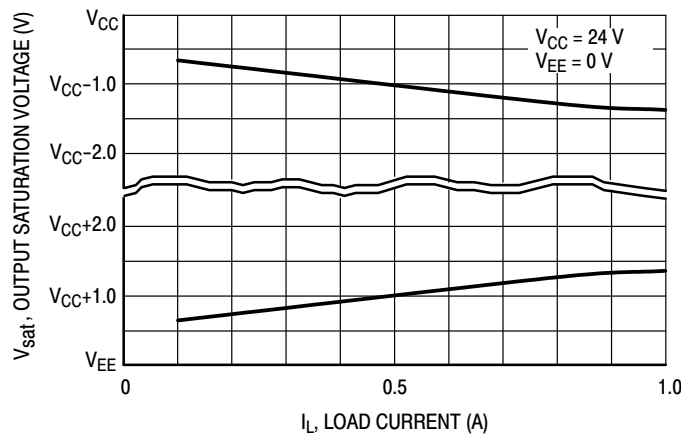

Figure 3. Output Saturation Voltage versus Load Current

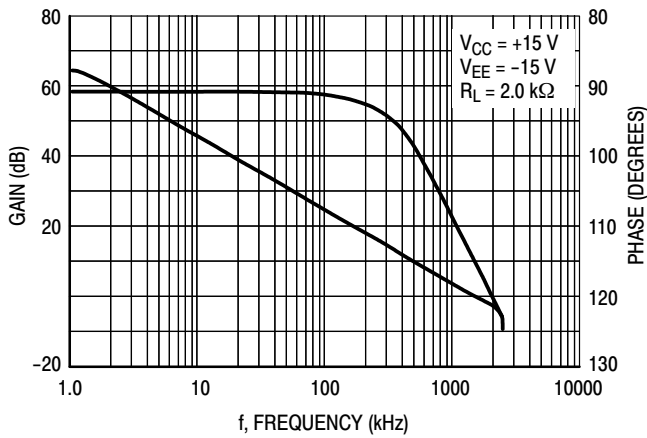

Figure 4. Voltage Gain and Phase versus Frequency

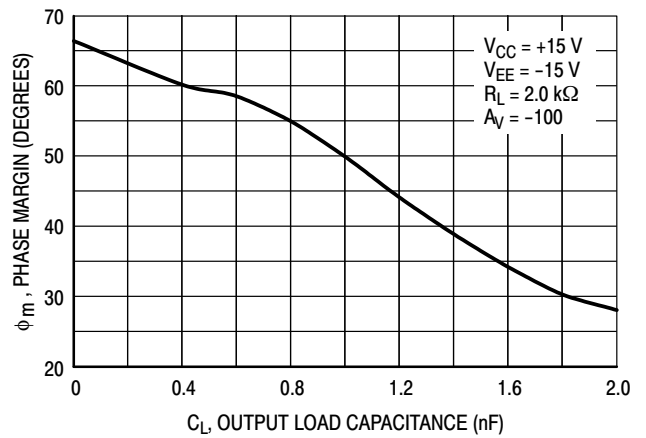

Figure 5. Phase Margin versus Output Load Capacitance

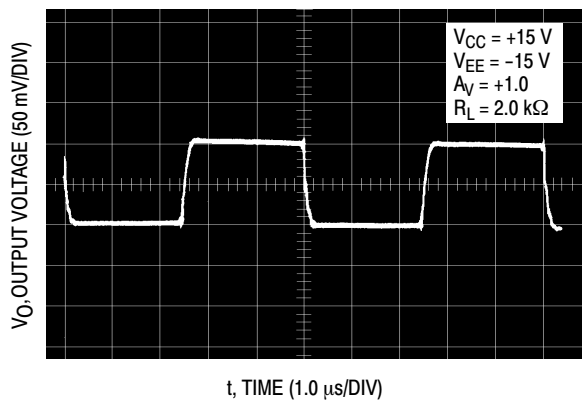

Figure 6. Small Signal Transient Response

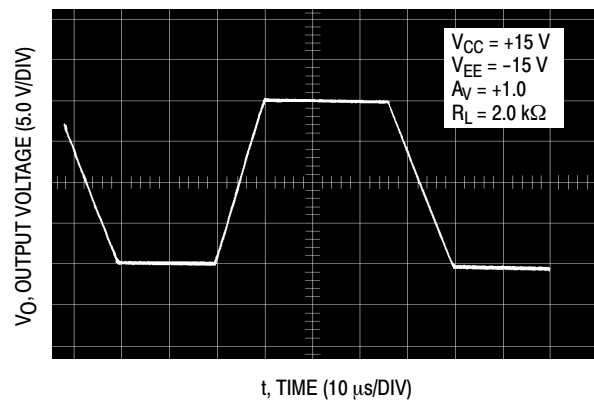

Figure 7. Large Signal Transient Response

TCA0372, TCA0372B, NCV0372B

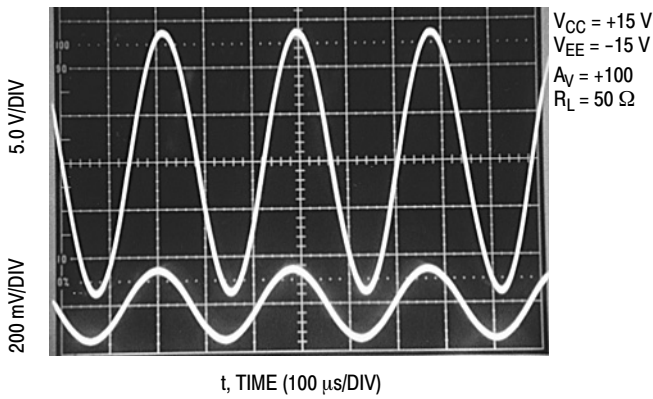

Figure 8. Sine Wave Response

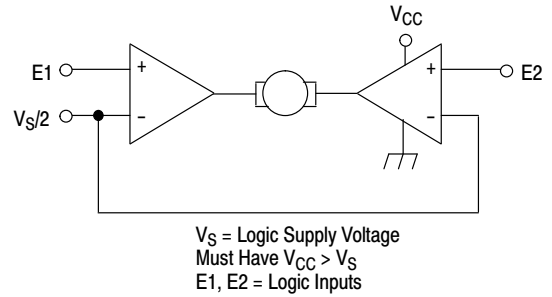
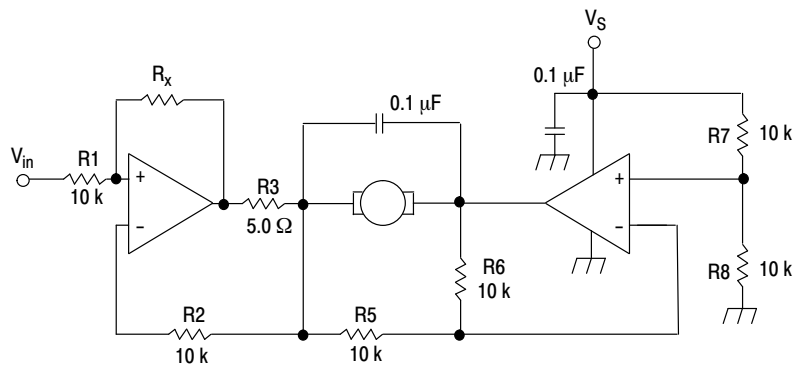

Figure 9. Bidirectional DC Motor Control with Microprocessor-Compatible Inputs



For circuit stability, ensure that $R_x > \frac{2R_3 \cdot R_1}{R_M}$ where, R_M = internal resistance of motor.
 The voltage available at the terminals of the motor is: $V_M = 2(V_1 - \frac{V_S}{2}) + |R_0| \cdot I_M$
 where, $|R_0| = \frac{2R_3 \cdot R_1}{R_x}$ and I_M is the motor current.

Figure 10. Bidirectional Speed Control of DC Motors

ORDERING INFORMATION

Device	Package	Shipping†
TCA0372DWR2G	SOIC-16W (Pb-Free)	1000 / Tape & Reel
TCA0372BDWR2G	SOIC-16W (Pb-Free)	1000 / Tape & Reel
NCV0372BDWR2G*	SOIC-16W (Pb-Free)	1000 / Tape & Reel

†For information on tape and reel specifications, including part orientation and tape sizes, please refer to our Tape and Reel Packaging Specifications Brochure, BRD8011/D.

*AEC-Q100 Qualified and PPAP Capable

MECHANICAL CASE OUTLINE PACKAGE DIMENSIONS



1
SCALE 1:1

SOIC-16 WB
CASE 751G
ISSUE E

DATE 08 OCT 2021

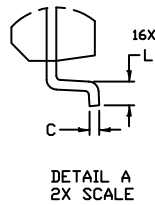

NOTES:

1. DIMENSIONING AND TOLERANCING PER ASME Y14.5M, 1994.
2. CONTROLLING DIMENSION: MILLIMETERS
3. DIMENSION b DOES NOT INCLUDE DAMBAR PROTRUSION. ALLOWABLE PROTRUSION SHALL BE 0.13 TOTAL IN EXCESS OF B DIMENSION AT MAXIMUM MATERIAL CONDITION.
4. DIMENSIONS D AND E DO NOT INCLUDE MOLD PROTRUSIONS.
5. MAXIMUM MOLD PROTRUSION OR FLASH TO BE 0.15 PER SIDE.

DIM	MILLIMETERS	
	MIN.	MAX.
A	2.35	2.65
A1	0.10	0.25
B	0.35	0.49
C	0.23	0.32
D	10.15	10.45
E	7.40	7.60
e	1.27 BSC	
H	10.05	10.55
h	0.53 REF	
L	0.50	0.90
M	0°	7°

GENERIC MARKING DIAGRAM*

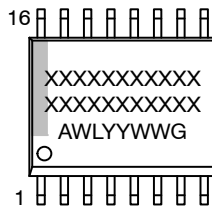

- XXXXX = Specific Device Code
- A = Assembly Location
- WL = Wafer Lot
- YY = Year
- WW = Work Week
- G = Pb-Free Package

*This information is generic. Please refer to device data sheet for actual part marking. Pb-Free indicator, "G" or microdot "▪", may or may not be present. Some products may not follow the Generic Marking.

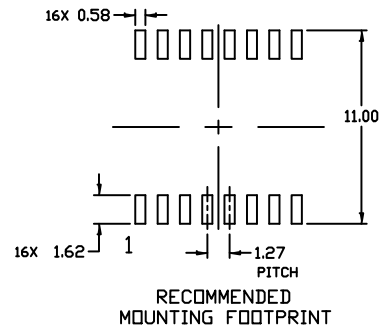

DOCUMENT NUMBER:	98ASB42567B	Electronic versions are uncontrolled except when accessed directly from the Document Repository. Printed versions are uncontrolled except when stamped "CONTROLLED COPY" in red.
DESCRIPTION:	SOIC-16 WB	PAGE 1 OF 1

onsemi and ONSEMI are trademarks of Semiconductor Components Industries, LLC dba onsemi or its subsidiaries in the United States and/or other countries. onsemi reserves the right to make changes without further notice to any products herein. onsemi makes no warranty, representation or guarantee regarding the suitability of its products for any particular purpose, nor does onsemi assume any liability arising out of the application or use of any product or circuit, and specifically disclaims any and all liability, including without limitation special, consequential or incidental damages. onsemi does not convey any license under its patent rights nor the rights of others.

onsemi, **Onsemi**, and other names, marks, and brands are registered and/or common law trademarks of Semiconductor Components Industries, LLC dba "**onsemi**" or its affiliates and/or subsidiaries in the United States and/or other countries. **onsemi** owns the rights to a number of patents, trademarks, copyrights, trade secrets, and other intellectual property. A listing of **onsemi**'s product/patent coverage may be accessed at www.onsemi.com/site/pdf/Patent-Marking.pdf. **onsemi** reserves the right to make changes at any time to any products or information herein, without notice. The information herein is provided "as-is" and **onsemi** makes no warranty, representation or guarantee regarding the accuracy of the information, product features, availability, functionality, or suitability of its products for any particular purpose, nor does **onsemi** assume any liability arising out of the application or use of any product or circuit, and specifically disclaims any and all liability, including without limitation special, consequential or incidental damages. Buyer is responsible for its products and applications using **onsemi** products, including compliance with all laws, regulations and safety requirements or standards, regardless of any support or applications information provided by **onsemi**. "Typical" parameters which may be provided in **onsemi** data sheets and/or specifications can and do vary in different applications and actual performance may vary over time. All operating parameters, including "Typicals" must be validated for each customer application by customer's technical experts. **onsemi** does not convey any license under any of its intellectual property rights nor the rights of others. **onsemi** products are not designed, intended, or authorized for use as a critical component in life support systems or any FDA Class 3 medical devices or medical devices with a same or similar classification in a foreign jurisdiction or any devices intended for implantation in the human body. Should Buyer purchase or use **onsemi** products for any such unintended or unauthorized application, Buyer shall indemnify and hold **onsemi** and its officers, employees, subsidiaries, affiliates, and distributors harmless against all claims, costs, damages, and expenses, and reasonable attorney fees arising out of, directly or indirectly, any claim of personal injury or death associated with such unintended or unauthorized use, even if such claim alleges that **onsemi** was negligent regarding the design or manufacture of the part. **onsemi** is an Equal Opportunity/Affirmative Action Employer. This literature is subject to all applicable copyright laws and is not for resale in any manner.

PUBLICATION ORDERING INFORMATION

LITERATURE FULFILLMENT:

Email Requests to: orderlit@onsemi.com

onsemi Website: www.onsemi.com

TECHNICAL SUPPORT

North American Technical Support:

Voice Mail: 1 800-282-9855 Toll Free USA/Canada

Phone: 011 421 33 790 2910

Europe, Middle East and Africa Technical Support:

Phone: 00421 33 790 2910

For additional information, please contact your local Sales Representative

X-ON Electronics

Largest Supplier of Electrical and Electronic Components

Click to view similar products for [Operational Amplifiers - Op Amps](#) category:

Click to view products by [ON Semiconductor](#) manufacturer:

Other Similar products are found below :

[NCV33072ADR2G](#) [LM258AYDT](#) [LM358SNG](#) [430227FB](#) [UPC824G2-A](#) [LT1678IS8](#) [042225DB](#) [058184EB](#) [UPC822G2-A](#) [UPC259G2-A](#)
[UPC258G2-A](#) [NCV33202DMR2G](#) [NTE925](#) [AZV358MTR-G1](#) [AP4310AUMTR-AG1](#) [HA1630D02MMEL-E](#) [HA1630S01LPEL-E](#)
[SCY33178DR2G](#) [NJU77806F3-TE1](#) [NCV5652MUTWG](#) [NCV20034DR2G](#) [LM324EDR2G](#) [LM2902EDR2G](#) [NTE7155](#) [NTE778S](#) [NTE871](#)
[NTE924](#) [NTE937](#) [MCP6V17T-E/MNY](#) [MCP6V19-E/ST](#) [MXD8011HF](#) [MCP6V17T-E/MS](#) [SCY6358ADR2G](#) [ADA4523-1BCPZ](#)
[LTC2065HUD#PBF](#) [ADA4523-1BCPZ-RL7](#) [2SD965T-R](#) [RS6332PXK](#) [BDM8551](#) [BDM321](#) [MD1324](#) [COS8052SR](#) [COS8552SR](#)
[COS8554SR](#) [COS2177SR](#) [COS2353SR](#) [COS724TR](#) [ASOPD4580S-R](#) [RS321BKXF](#) [ADA4097-1HUIZ-RL7](#)