

Darlington Complementary Silicon Power Transistors



ON Semiconductor®

www.onsemi.com

TIP140, TIP141, TIP142, (NPN); TIP145, TIP146, TIP147, (PNP)

Designed for general-purpose amplifier and low frequency switching applications.

Features

- High DC Current Gain –
 $\text{Min } h_{FE} = 1000 @ I_C = 5.0 \text{ A, } V_{CE} = 4 \text{ V}$
- Collector–Emitter Sustaining Voltage – @ 30 mA
 $V_{CEO(sus)} = 60 \text{ Vdc (Min) – TIP140, TIP145}$
 $= 80 \text{ Vdc (Min) – TIP141, TIP146}$
 $= 100 \text{ Vdc (Min) – TIP142, TIP147}$
- Monolithic Construction with Built–In Base–Emitter Shunt Resistor
- These are Pb–Free Devices*

MAXIMUM RATINGS

Rating	Symbol	TIP140 TIP145	TIP141 TIP146	TIP142 TIP147	Unit
Collector – Emitter Voltage	V_{CEO}	60	80	100	Vdc
Collector – Base Voltage	V_{CB}	60	80	100	Vdc
Emitter – Base Voltage	V_{EB}	5.0			Vdc
Collector Current – Continuous – Peak (Note 1)	I_C	10 15			Adc
Base Current – Continuous	I_B	0.5			Adc
Total Power Dissipation @ $T_C = 25^\circ\text{C}$	P_D	125			W
Operating and Storage Junction Temperature Range	T_J, T_{stg}	–65 to +150			$^\circ\text{C}$

THERMAL CHARACTERISTICS

Characteristic	Symbol	Max	Unit
Thermal Resistance, Junction–to–Case	$R_{\theta JC}$	1.0	$^\circ\text{C/W}$
Thermal Resistance, Junction–to–Ambient	$R_{\theta JA}$	35.7	$^\circ\text{C/W}$

Stresses exceeding those listed in the Maximum Ratings table may damage the device. If any of these limits are exceeded, device functionality should not be assumed, damage may occur and reliability may be affected.

1. 5 ms, $\leq 10\%$ Duty Cycle.

*For additional information on our Pb–Free strategy and soldering details, please download the ON Semiconductor Soldering and Mounting Techniques Reference Manual, SOLDERRM/D.

10 AMPERE DARLINGTON COMPLEMENTARY SILICON POWER TRANSISTORS 60–100 VOLTS, 125 WATTS

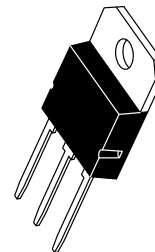

SOT–93 (TO–218)
CASE 340D
STYLE 1

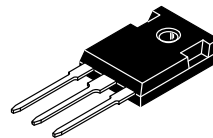

TO–247
CASE 340L
STYLE 3

NOTE: Effective June 2012 this device will be available only in the TO–247 package. Reference FPCN# 16827.

ORDERING INFORMATION

See detailed ordering and shipping information in the package dimensions section on page 2 of this data sheet.

TIP140, TIP141, TIP142, (NPN); TIP145, TIP146, TIP147, (PNP)

MARKING DIAGRAMS

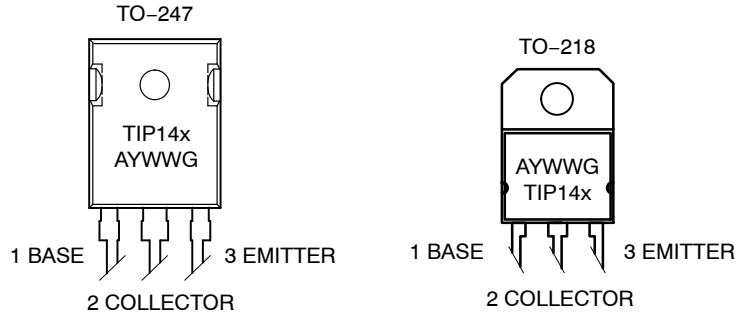

TIP14x = Device Code
 A = Assembly Location
 Y = Year
 WW = Work Week
 G = Pb-Free Package

DARLINGTON SCHEMATICS

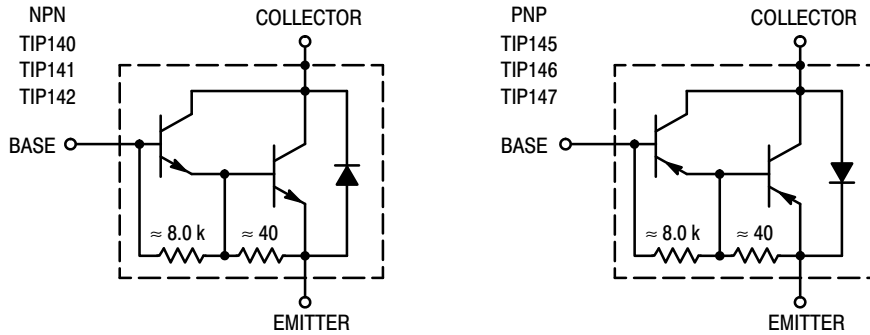

ORDERING INFORMATION

Device	Package	Shipping
TIP140G	SOT-93 (TO-218) (Pb-Free)	30 Units / Rail
TIP141G	SOT-93 (TO-218) (Pb-Free)	30 Units / Rail
TIP142G	SOT-93 (TO-218) (Pb-Free)	30 Units / Rail
TIP145G	SOT-93 (TO-218) (Pb-Free)	30 Units / Rail
TIP146G	SOT-93 (TO-218) (Pb-Free)	30 Units / Rail
TIP147G	SOT-93 (TO-218) (Pb-Free)	30 Units / Rail
TIP140G	TO-247 (Pb-Free)	30 Units / Rail
TIP141G	TO-247 (Pb-Free)	30 Units / Rail
TIP142G	TO-247 (Pb-Free)	30 Units / Rail
TIP145G	TO-247 (Pb-Free)	30 Units / Rail
TIP146G	TO-247 (Pb-Free)	30 Units / Rail
TIP147G	TO-247 (Pb-Free)	30 Units / Rail

TIP140, TIP141, TIP142, (NPN); TIP145, TIP146, TIP147, (PNP)

ELECTRICAL CHARACTERISTICS ($T_C = 25^\circ\text{C}$ unless otherwise noted)

Characteristic	Symbol	Min	Typ	Max	Unit
OFF CHARACTERISTICS					
Collector–Emitter Sustaining Voltage (Note 2) ($I_C = 30\text{ mA}$, $I_B = 0$)	$V_{CE(sus)}$	60 80 100	– – –	– – –	Vdc
Collector Cutoff Current ($V_{CE} = 30\text{ Vdc}$, $I_B = 0$) ($V_{CE} = 40\text{ Vdc}$, $I_B = 0$) ($V_{CE} = 50\text{ Vdc}$, $I_B = 0$)	I_{CEO}	– – –	– – –	2.0 2.0 2.0	mA
Collector Cutoff Current ($V_{CB} = 60\text{ V}$, $I_E = 0$) ($V_{CB} = 80\text{ V}$, $I_E = 0$) ($V_{CB} = 100\text{ V}$, $I_E = 0$)	I_{CBO}	– – –	– – –	1.0 1.0 1.0	mA
Emitter Cutoff Current ($V_{BE} = 5.0\text{ V}$)	I_{EBO}	–	–	2.0	mA

ON CHARACTERISTICS (Note 2)

DC Current Gain ($I_C = 5.0\text{ A}$, $V_{CE} = 4.0\text{ V}$) ($I_C = 10\text{ A}$, $V_{CE} = 4.0\text{ V}$)	h_{FE}	1000 500	– –	– –	–
Collector–Emitter Saturation Voltage ($I_C = 5.0\text{ A}$, $I_B = 10\text{ mA}$) ($I_C = 10\text{ A}$, $I_B = 40\text{ mA}$)	$V_{CE(sat)}$	– –	– –	2.0 3.0	Vdc
Base–Emitter Saturation Voltage ($I_C = 10\text{ A}$, $I_B = 40\text{ mA}$)	$V_{BE(sat)}$	–	–	3.5	Vdc
Base–Emitter On Voltage ($I_C = 10\text{ A}$, $V_{CE} = 4.0\text{ Vdc}$)	$V_{BE(on)}$	–	–	3.0	Vdc

SWITCHING CHARACTERISTICS

Resistive Load (See Figure 1)						
Delay Time	$(V_{CC} = 30\text{ V}$, $I_C = 5.0\text{ A}$, $I_B = 20\text{ mA}$, Duty Cycle $\leq 2.0\%$, $I_{B1} = I_{B2}$, R_C & R_B Varied, $T_J = 25^\circ\text{C}$)	t_d	–	0.15	–	μs
Rise Time		t_r	–	0.55	–	μs
Storage Time		t_s	–	2.5	–	μs
Fall Time		t_f	–	2.5	–	μs

2. Pulse Test: Pulse Width = 300 μs , Duty Cycle $\leq 2.0\%$.

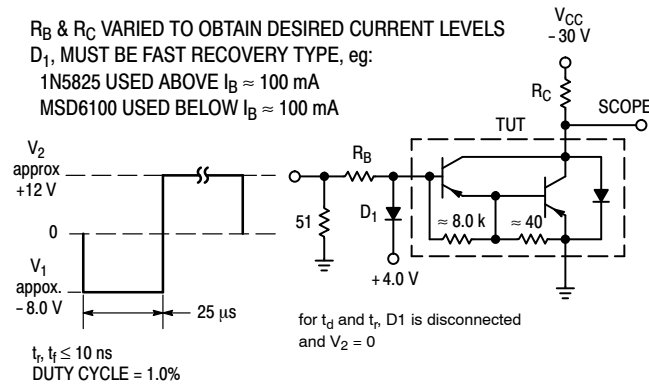

For NPN test circuit reverse diode and voltage polarities.

Figure 1. Switching Times Test Circuit

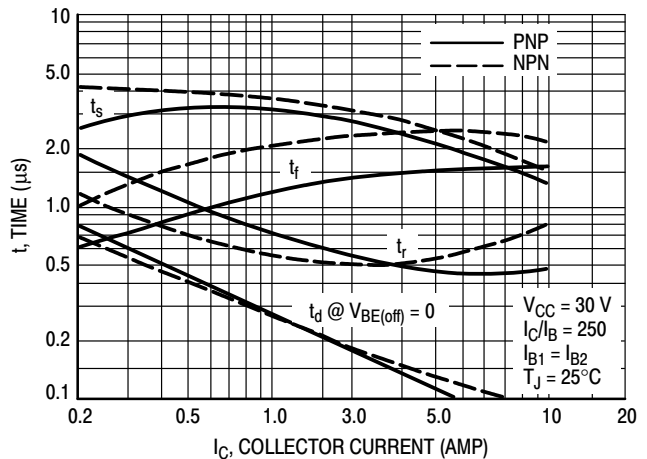

Figure 2. Switching Times

TIP140, TIP141, TIP142, (NPN); TIP145, TIP146, TIP147, (PNP)

TYPICAL CHARACTERISTICS

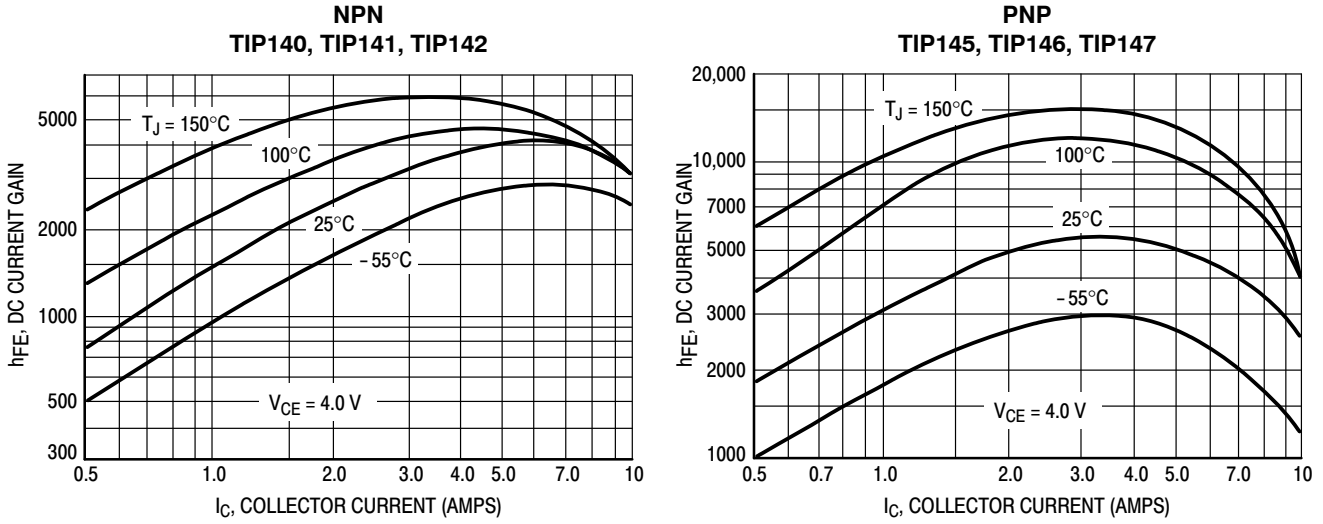

Figure 3. DC Current Gain versus Collector Current

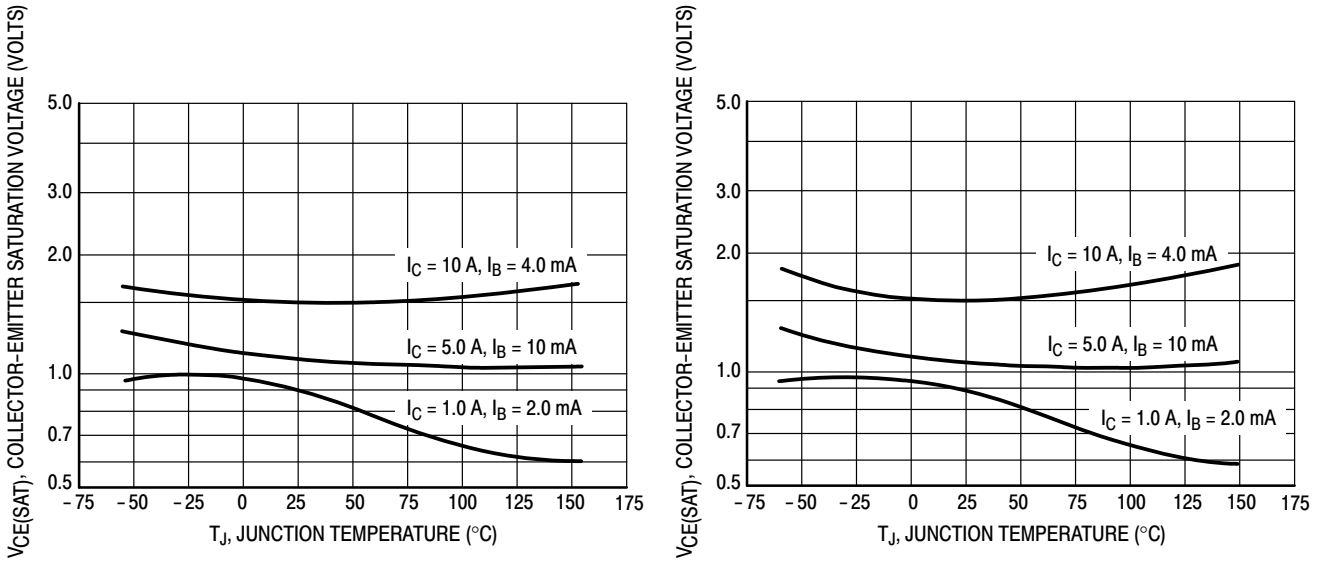

Figure 4. Collector-Emitter Saturation Voltage

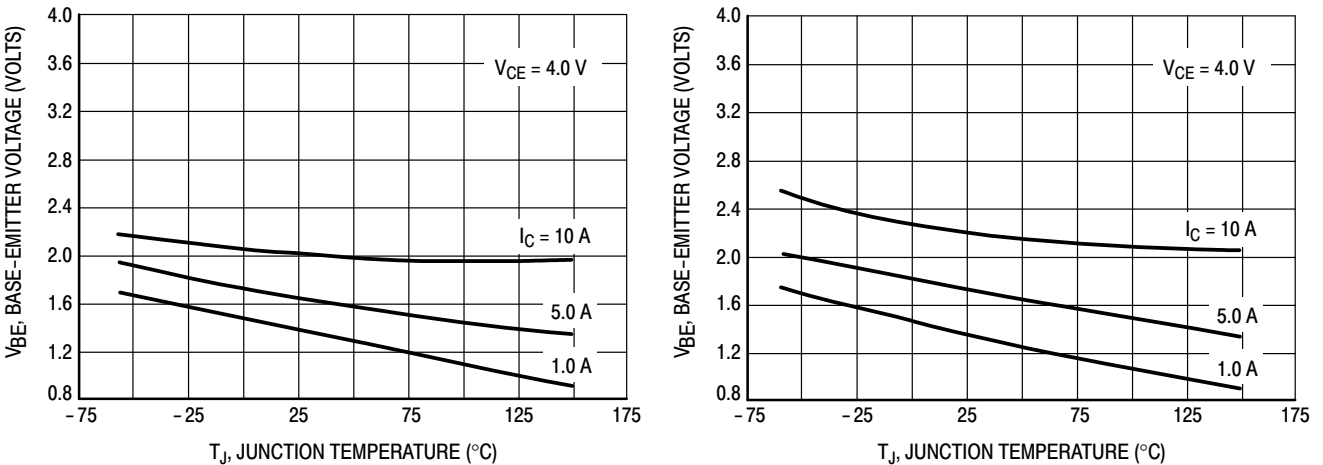

Figure 5. Base-Emitter Voltage

TIP140, TIP141, TIP142, (NPN); TIP145, TIP146, TIP147, (PNP)

ACTIVE-REGION SAFE OPERATING AREA

There are two limitations on the power handling ability of a transistor: average junction temperature and second breakdown. Safe operating area curves indicate $I_C - V_{CE}$ limits of the transistor that must be observed for reliable operation; i.e., the transistor must not be subjected to greater dissipation than the curves indicate.

The data of Figure 6 is based on $T_{J(pk)} = 150^\circ\text{C}$; T_C is variable depending on conditions. At high case temperatures, thermal limitations will reduce the power that can be handled to values less than the limitations imposed by second breakdown.

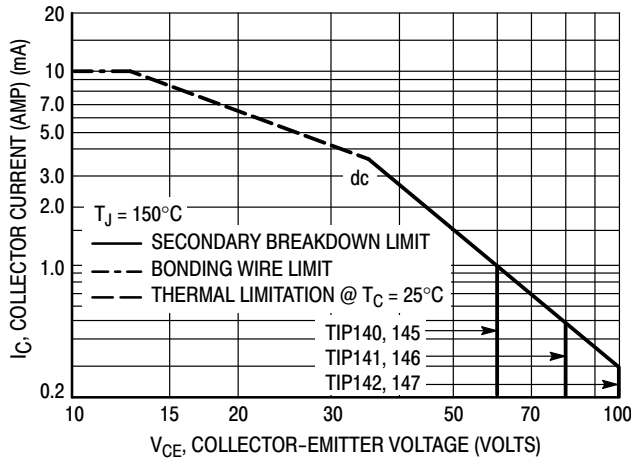

Figure 6. Active-Region Safe Operating Area

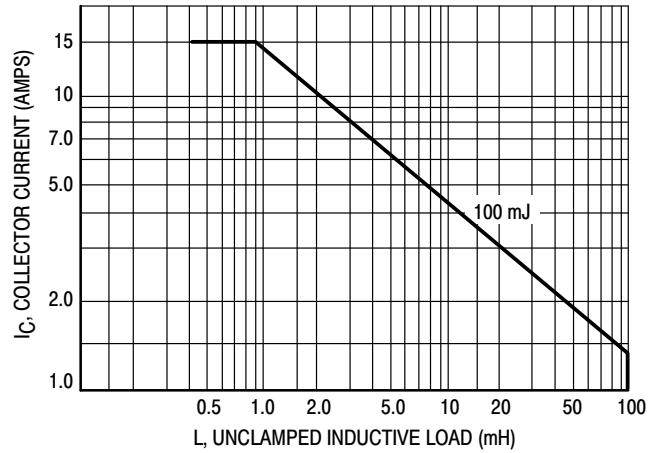
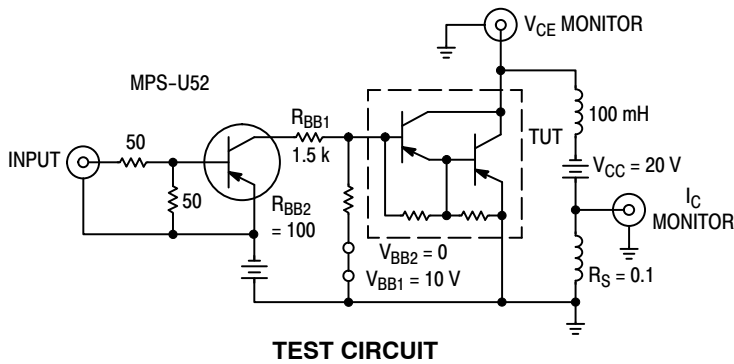
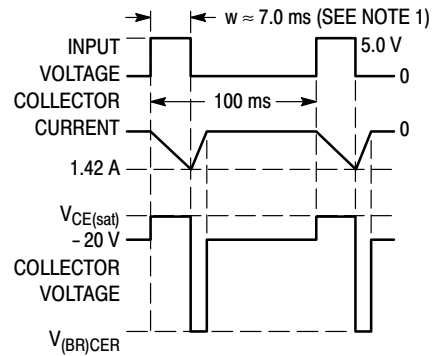

Figure 7. Unclamped Inductive Load



TEST CIRCUIT

NOTE 1: Input pulse width is increased until $I_{CM} = 1.42\text{ A}$.
NOTE 2: For NPN test circuit reverse polarities.



VOLTAGE AND CURRENT WAVEFORMS

Figure 8. Inductive Load

TIP140, TIP141, TIP142, (NPN); TIP145, TIP146, TIP147, (PNP)

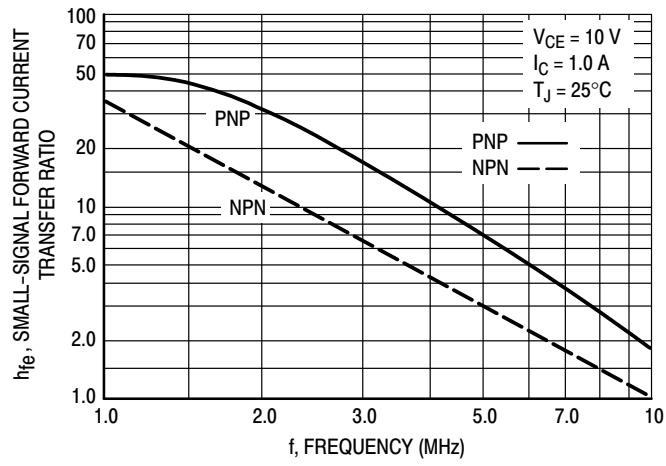

Figure 9. Magnitude of Common Emitter Small-Signal Short-Circuit Forward Current Transfer Ratio

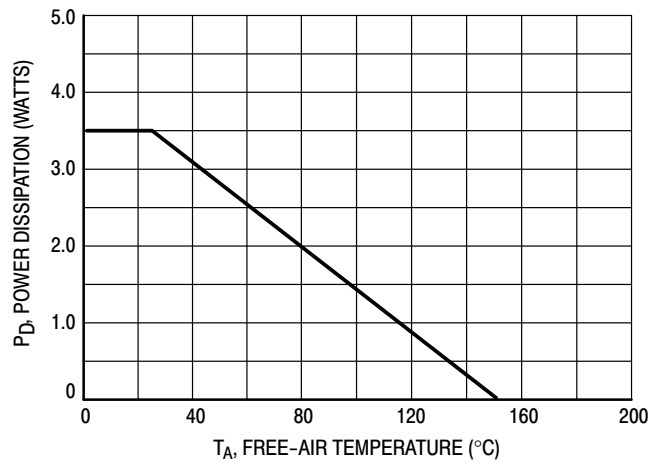

Figure 10. Free-Air Temperature Power Derating

MECHANICAL CASE OUTLINE

PACKAGE DIMENSIONS

ON Semiconductor®



SOT-93 (TO-218) CASE 340D-02 ISSUE E

DATE 01/03/2002

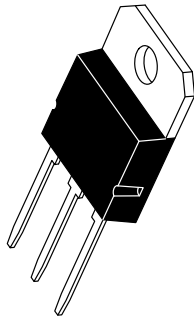

SCALE 1:1

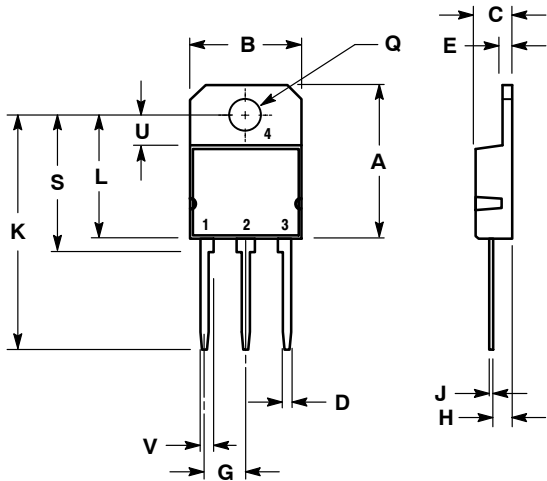

STYLE 1:
PIN 1. BASE
2. COLLECTOR
3. EMITTER
4. COLLECTOR

STYLE 2:
PIN 1. ANODE
2. CATHODE
3. ANODE
4. CATHODE

- NOTES:
1. DIMENSIONING AND TOLERANCING PER ANSI Y14.5M, 1982.
2. CONTROLLING DIMENSION: MILLIMETER.

DIM	MILLIMETERS		INCHES	
	MIN	MAX	MIN	MAX
A	---	20.35	---	0.801
B	14.70	15.20	0.579	0.598
C	4.70	4.90	0.185	0.193
D	1.10	1.30	0.043	0.051
E	1.17	1.37	0.046	0.054
G	5.40	5.55	0.213	0.219
H	2.00	3.00	0.079	0.118
J	0.50	0.78	0.020	0.031
K	31.00 REF		1.220 REF	
L	---	16.20	---	0.638
Q	4.00	4.10	0.158	0.161
S	17.80	18.20	0.701	0.717
U	4.00 REF		0.157 REF	
V	1.75 REF		0.069	

MARKING DIAGRAM

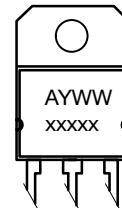

A = Assembly Location
Y = Year
WW = Work Week
xxxxx = Device Code

DOCUMENT NUMBER:	98ASB42643B	Electronic versions are uncontrolled except when accessed directly from the Document Repository. Printed versions are uncontrolled except when stamped "CONTROLLED COPY" in red.
DESCRIPTION:	SOT-93	PAGE 1 OF 1

ON Semiconductor and are trademarks of Semiconductor Components Industries, LLC dba ON Semiconductor or its subsidiaries in the United States and/or other countries. ON Semiconductor reserves the right to make changes without further notice to any products herein. ON Semiconductor makes no warranty, representation or guarantee regarding the suitability of its products for any particular purpose, nor does ON Semiconductor assume any liability arising out of the application or use of any product or circuit, and specifically disclaims any and all liability, including without limitation special, consequential or incidental damages. ON Semiconductor does not convey any license under its patent rights nor the rights of others.

MECHANICAL CASE OUTLINE PACKAGE DIMENSIONS

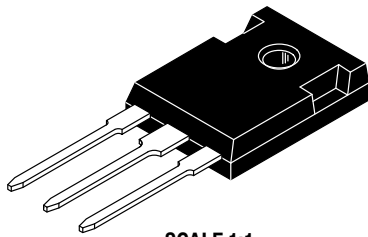

TO-247
CASE 340L
ISSUE G

DATE 06 OCT 2021

SCALE 1:1

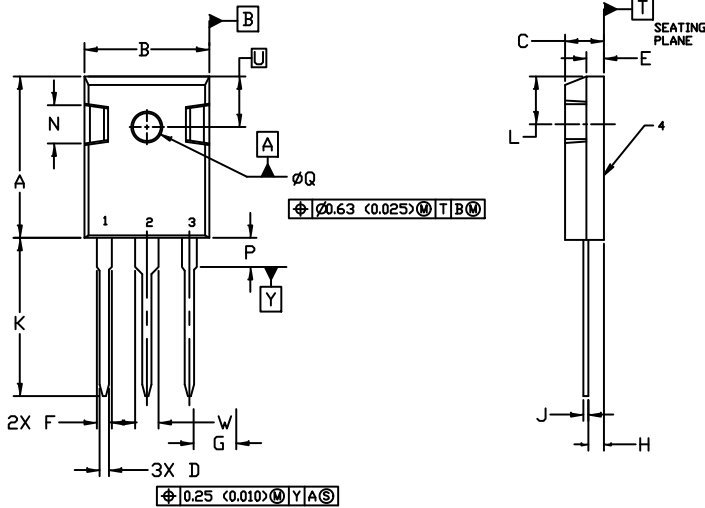

NOTES:

1. DIMENSIONING AND TOLERANCING PER ASME Y14.5M, 1982.
2. CONTROLLING DIMENSION: MILLIMETER

DIM	MILLIMETERS		INCHES	
	MIN.	MAX.	MIN.	MAX.
A	20.32	21.08	0.800	0.830
B	15.75	16.26	0.620	0.640
C	4.70	5.30	0.185	0.209
D	1.00	1.40	0.040	0.055
E	1.90	2.60	0.075	0.102
F	1.65	2.13	0.065	0.084
G	5.45 BSC		0.215 BSC	
H	1.50	2.49	0.059	0.098
J	0.40	0.80	0.016	0.031
K	19.81	20.83	0.780	0.820
L	5.40	6.20	0.212	0.244
N	4.32	5.49	0.170	0.216
P	----	4.50	----	0.177
Q	3.55	3.65	0.140	0.144
U	6.15 BSC		0.242 BSC	
W	2.87	3.12	0.113	0.123

GENERIC
MARKING DIAGRAM*

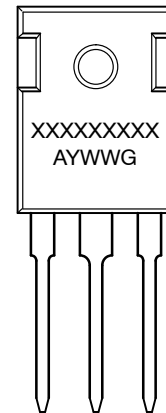

- | | | | |
|--|--|--|--|
| <p>STYLE 1:
PIN 1. GATE
2. DRAIN
3. SOURCE
4. DRAIN</p> | <p>STYLE 2:
PIN 1. ANODE
2. CATHODE (S)
3. ANODE 2
4. CATHODES (S)</p> | <p>STYLE 3:
PIN 1. BASE
2. COLLECTOR
3. EMITTER
4. COLLECTOR</p> | <p>STYLE 4:
PIN 1. GATE
2. COLLECTOR
3. EMITTER
4. COLLECTOR</p> |
| <p>STYLE 5:
PIN 1. CATHODE
2. ANODE
3. GATE
4. ANODE</p> | <p>STYLE 6:
PIN 1. MAIN TERMINAL 1
2. MAIN TERMINAL 2
3. GATE
4. MAIN TERMINAL 2</p> | | |

- XXXXXX = Specific Device Code
A = Assembly Location
Y = Year
WW = Work Week
G = Pb-Free Package

*This information is generic. Please refer to device data sheet for actual part marking. Pb-Free indicator, "G" or microdot "▪", may or may not be present. Some products may not follow the Generic Marking.

DOCUMENT NUMBER:	98ASB15080C	Electronic versions are uncontrolled except when accessed directly from the Document Repository. Printed versions are uncontrolled except when stamped "CONTROLLED COPY" in red.
DESCRIPTION:	TO-247	PAGE 1 OF 1

onsemi and onsemi are trademarks of Semiconductor Components Industries, LLC dba onsemi or its subsidiaries in the United States and/or other countries. onsemi reserves the right to make changes without further notice to any products herein. onsemi makes no warranty, representation or guarantee regarding the suitability of its products for any particular purpose, nor does onsemi assume any liability arising out of the application or use of any product or circuit, and specifically disclaims any and all liability, including without limitation special, consequential or incidental damages. onsemi does not convey any license under its patent rights nor the rights of others.

onsemi, **Onsemi**, and other names, marks, and brands are registered and/or common law trademarks of Semiconductor Components Industries, LLC dba "**onsemi**" or its affiliates and/or subsidiaries in the United States and/or other countries. **onsemi** owns the rights to a number of patents, trademarks, copyrights, trade secrets, and other intellectual property. A listing of **onsemi**'s product/patent coverage may be accessed at www.onsemi.com/site/pdf/Patent-Marking.pdf. **onsemi** reserves the right to make changes at any time to any products or information herein, without notice. The information herein is provided "as-is" and **onsemi** makes no warranty, representation or guarantee regarding the accuracy of the information, product features, availability, functionality, or suitability of its products for any particular purpose, nor does **onsemi** assume any liability arising out of the application or use of any product or circuit, and specifically disclaims any and all liability, including without limitation special, consequential or incidental damages. Buyer is responsible for its products and applications using **onsemi** products, including compliance with all laws, regulations and safety requirements or standards, regardless of any support or applications information provided by **onsemi**. "Typical" parameters which may be provided in **onsemi** data sheets and/or specifications can and do vary in different applications and actual performance may vary over time. All operating parameters, including "Typicals" must be validated for each customer application by customer's technical experts. **onsemi** does not convey any license under any of its intellectual property rights nor the rights of others. **onsemi** products are not designed, intended, or authorized for use as a critical component in life support systems or any FDA Class 3 medical devices or medical devices with a same or similar classification in a foreign jurisdiction or any devices intended for implantation in the human body. Should Buyer purchase or use **onsemi** products for any such unintended or unauthorized application, Buyer shall indemnify and hold **onsemi** and its officers, employees, subsidiaries, affiliates, and distributors harmless against all claims, costs, damages, and expenses, and reasonable attorney fees arising out of, directly or indirectly, any claim of personal injury or death associated with such unintended or unauthorized use, even if such claim alleges that **onsemi** was negligent regarding the design or manufacture of the part. **onsemi** is an Equal Opportunity/Affirmative Action Employer. This literature is subject to all applicable copyright laws and is not for resale in any manner.

PUBLICATION ORDERING INFORMATION

LITERATURE FULFILLMENT:

Email Requests to: orderlit@onsemi.com

onsemi Website: www.onsemi.com

TECHNICAL SUPPORT

North American Technical Support:

Voice Mail: 1 800-282-9855 Toll Free USA/Canada

Phone: 011 421 33 790 2910

Europe, Middle East and Africa Technical Support:

Phone: 00421 33 790 2910

For additional information, please contact your local Sales Representative

X-ON Electronics

Largest Supplier of Electrical and Electronic Components

Click to view similar products for [Darlington Transistors](#) category:

Click to view products by [ON Semiconductor](#) manufacturer:

Other Similar products are found below :

[NJVMJD128T4G](#) [281287X](#) [BDV64B](#) [NJVMJD117T4G](#) [LB1205-L-E](#) [2N6053](#) [MPSA14](#) [TIP140](#) [MPSA13](#) [TIP127L-BP](#) [2N6383](#)
[ULN2003ACM/TR](#) [2N7371](#) [2N6058](#) [2N6059](#) [2N6051](#) [MJ2501](#) [MJ3001](#) [2SB1560](#) [2SB852KT146B](#) [2SD2560](#) [TIP112TU](#) [BCV27](#)
[MMBTA13-TP](#) [MMSTA28T146](#) [NTE2557](#) [NJVNJD35N04T4G](#) [MPSA29-D26Z](#) [FJB102TM](#) [BSP61H6327XTSA1](#) [BU941ZPFI](#)
[2SD1980TL](#) [NTE2350](#) [NTE245](#) [NTE246](#) [NTE2649](#) [NTE46](#) [NTE98](#) [ULN2003ADR2G](#) [NTE2344](#) [NTE2349](#) [NTE2405](#) [NTE243](#) [NTE244](#)
[NTE247](#) [NTE248](#) [NTE249](#) [NTE253](#) [NTE2548](#) [NTE261](#)