

SNAP B-SERIES RACKS

Features

- > Secure mounting for SNAP I/O modules plus a SNAP brain or on-the-rack SNAP controller
- > Analog, digital, and serial modules on the same rack
- > Panel or DIN-rail mounting
- > Modules snap into place

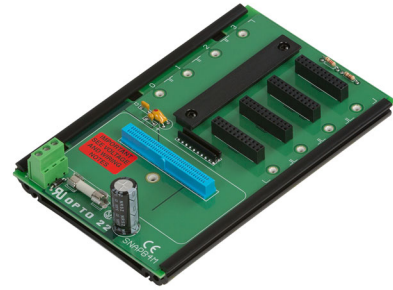

SNAP B-Series Rack

DESCRIPTION

NOTE: For racks to use with SNAP PAC controllers and brains, see Opto 22 form #1684, the *SNAP PAC Racks Data Sheet*.

NOTE: M-series racks (such as the SNAP-M64), used with SNAP Simple brains and SNAP-UP1-M64 controllers, have been replaced by SNAP PAC racks. See form #1684.

SNAP B-series mounting racks are designed to hold an intelligent SNAP I/O processor—either a SNAP brain or an on-the-rack controller—and several I/O modules.

This rack family includes racks that are compatible with ARCNET and serial SNAP brains, including those using Modbus® and Profibus® protocols, and with some Ethernet-based SNAP Ultimate I/O™ on-the-rack controllers and SNAP Ethernet I/O™ brains. For specific processor compatibility, see “Specifications” on page 3.

Since SNAP analog, digital, and serial I/O modules have the same footprint, customers using most SNAP B-series racks can mix modules on the same I/O mounting rack. However, module types, features, and positions on the rack vary depending on the capabilities of the brain or on-the-rack controller used. See the brain or controller data sheet for details.

Field devices are wired directly to the top-mounted removable connectors on the modules plugged into each rack. SNAP B-series racks can accommodate up to 4, 8, 12, or 16 modules. The module and rack design allows modules to simply “snap” on and off the mounting rack.

SNAP racks use a retention rail locking system that holds modules securely to the rack. Normally, a hold-down screw is not required. However, for applications that require additional module security, SNAP racks have provisions for two 4-40 by ½-inch standard machine screws to hold each module in position.

MC and MC-P model racks provide an auxiliary screw-type terminal strip for field wiring common connections such as loop power distribution. MC racks use a fixed terminal strip, while MC-P racks use removable connectors for easy maintenance (see enlarged view on the following page).

All SNAP racks offer panel mounting and the option of DIN-rail mounting. SNAP racks require a 5 VDC power source.

Part Numbers

Part	Description
SNAP-B4M	4-module rack
SNAP-B8M	8-module rack
SNAP-B12M	12-module rack
SNAP-B16M	16-module rack
SNAP-B8MC	8-module rack with extra terminal block for field wiring
SNAP-B12MC	12-module rack with extra terminal block for field wiring
SNAP-B16MC	16-module rack with extra terminal block for field wiring
SNAP-B8MC-P [OBSOLETE]	[OBSOLETE] 8-module rack with extra terminal block for field wiring, pluggable
SNAP-B12MC-P [OBSOLETE]	[OBSOLETE] 12-module rack with extra terminal block for field wiring, pluggable
SNAP-B16MC-P [OBSOLETE]	[OBSOLETE] 16-module rack with extra terminal block for field wiring, pluggable
SNAP-D64RS [OBSOLETE]	[OBSOLETE] 16-module rack for digital-only SNAP Ultimate, SNAP Ethernet, and SNAP-PDPRS64 Profibus brains
SNAP-FUSE7.5AB	7.5-amp fuse, 25-pack
SNAP-FUSE4AB	4-amp fuse, 25-pack
SNAP-FUSE1AB	1-amp fuse, 25-pack
SNAP-TEX-DRC10	SNAP PAC rack DIN-rail adapter clip, 10-pack
SNAP-TEX-REC10N	Narrow end cap for SNAP PAC racks DIN-rail assemblies, 10-pack
SNAP-TEX-REC10W	Wide end cap for SNAP PAC racks DIN-rail assemblies with terminal strips, 10-pack

DESCRIPTION (CONTINUED)

SNAP-B8M (8-Module Position I/O Mounting Rack)

Shown with B3000 brain (purchased separately)

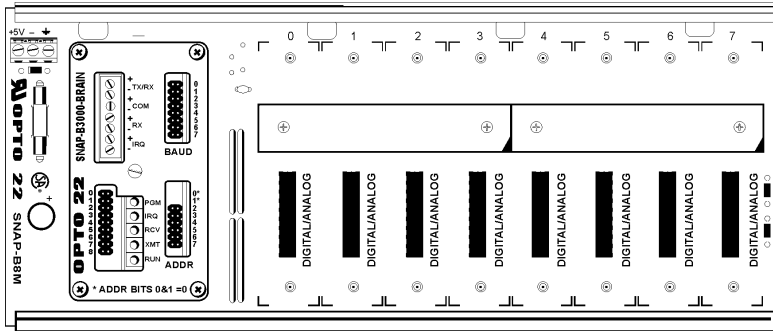

SNAP-B8MC (8-Module Position I/O Mounting Rack)

Shown with B3000 brain (purchased separately)

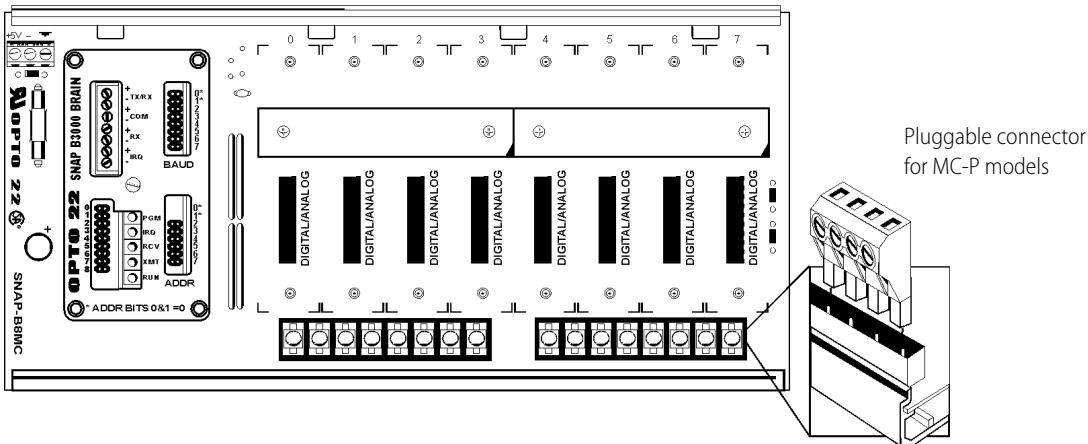

SPECIFICATIONS

Part Number	Description ¹	Power ² Requirements	I/O Processor ³ Compatibility	Replacement Fuse	Operating Temperature	Relative Humidity
SNAP-B4M ⁶	4-module mixed	5.0 to 5.2 VDC @ 1.8 Amps max				
SNAP-B8M ⁶	8-module mixed					
SNAP-B8MC ⁶	8-module mixed, terminal block	5.0 to 5.2 VDC @ 2.6 Amps max	SNAP-UP1-ADS SNAP-B3000-ENET SNAP-ENET-RTC			
SNAP-B8MC-P ⁶ [OBSOLETE]	8-module mixed, pluggable terminal block		B3000			
SNAP-B12M ⁶	12-module mixed ⁴		B3000-HA	SNAP-FUSE4A or Bel ⁵ 5HF4		
SNAP-B12MC ⁶	12-module mixed ⁴ , terminal block	5.0 to 5.2 VDC @ 3.4 Amps max	SNAP-B4 SNAP-B6 SNAP-BRS		0 to 70 °C	95%, non-con- densing
SNAP-B12MC-P ⁶ [OBSOLETE]	12-module mixed ⁴ , pluggable terminal block		SNAP-BRS-HA SNAP-B3000- MODBUS			
SNAP-B16M ⁶	16-module mixed ⁴					
SNAP-B16MC ⁶	16-module mixed ⁴ , terminal block	5.0 to 5.2 VDC @ 4.2 Amps max				
SNAP-B16MC-P ⁶ [OBSOLETE]	16-module mixed ⁴ , pluggable terminal block					
SNAP-D64RS ⁷ [OBSOLETE]	16-module digital only (limited digital functions)	5.0 to 5.2 VDC @ 1.8 Amps max	SNAP-UP1-D64 SNAP-ENET-D64 SNAP-PDPRS64	SNAP-FUSE1A or Buss ⁵ GDC1A		

1 "Mixed" means the rack can hold analog, digital, and serial modules. Most Ethernet-based I/O processors handle all these types of modules; other processors do not. See the processor's data sheet for details.

2 Power requirements shown are for a rack, a processor, and a full load of 2-channel analog modules (for the SNAP-D64RS, a full load of 4-channel digital modules). Power requirements for other SNAP modules are higher. See module data sheets.

3 "I/O Processor" means a SNAP brain or on-the-rack controller.

4 Four-channel SNAP digital modules can be used in positions 0–7 only.

5 Manufacturer's part number (not available through Opto 22).

6 Agency Approvals include: UL, CE, RoHS, DFARS; UKCA

7 Agency Approvals include: CE, RoHS, DFARS; UKCA

Verification Environment

All models:

Power schematic

For fuse part numbers, see Specifications on [page 3](#).

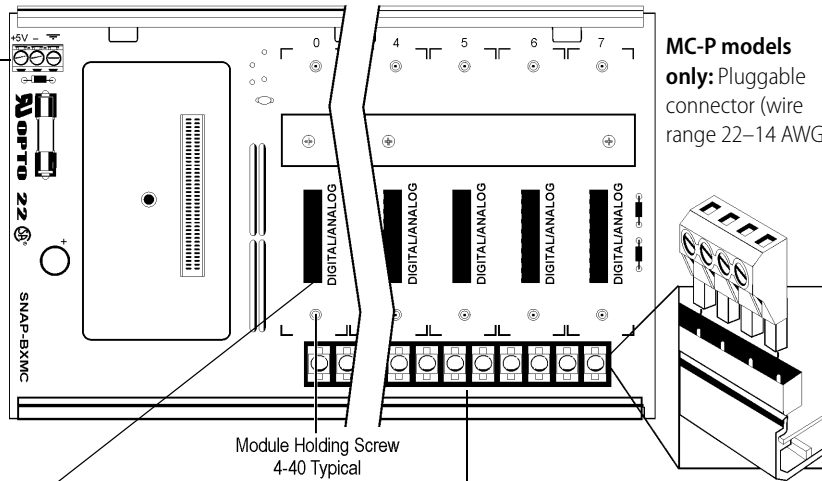
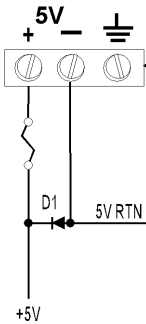

All models: Module mating connector pinout (female)

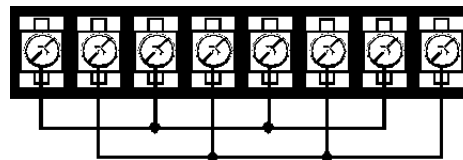
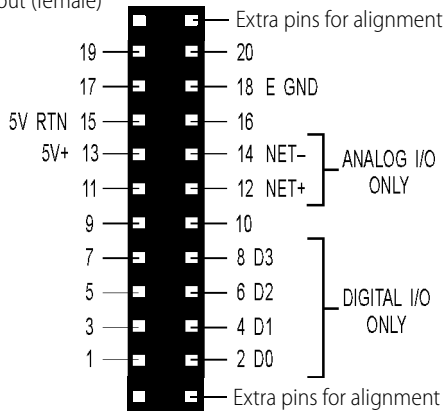

MC and MC-P models only: For detailed information on terminal strip usage, see [page 12](#) through [page 16](#).

IMPORTANT: The mounting rack connector has 24 pins; the module connector has 20 pins. The extra pins on the mounting rack connector prevent misalignment of the module during installation.

DIMENSIONAL DRAWINGS

Dimensions—SNAP-D64RS Rack and B-Series Racks with Terminal Strips

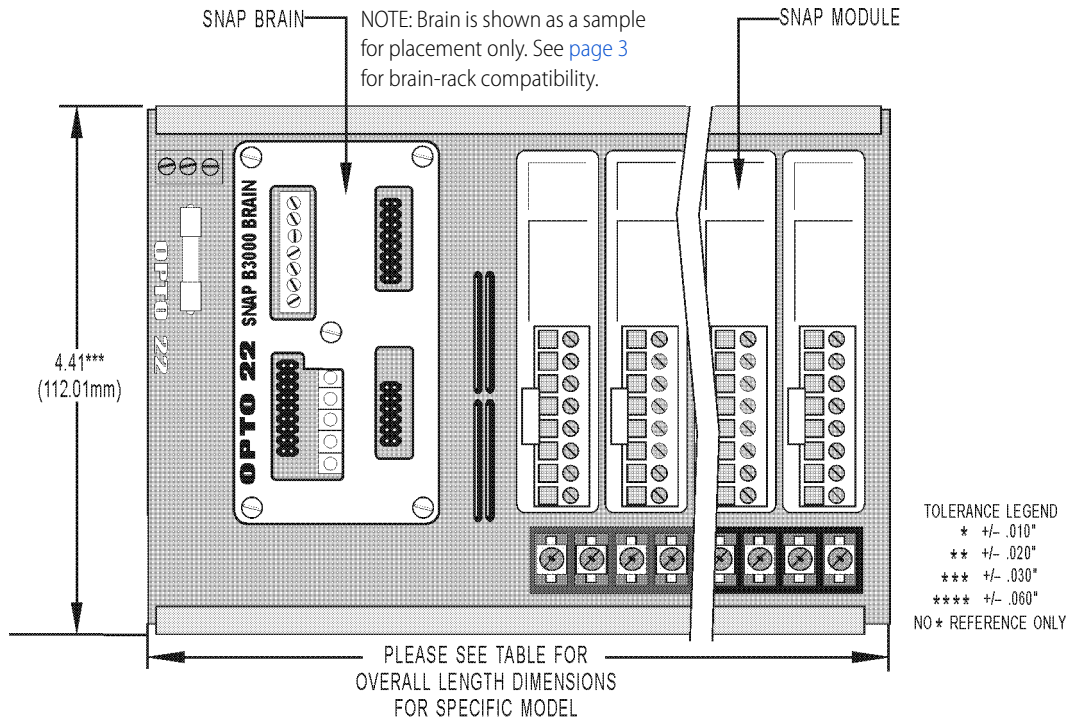

Overall Length Dimensions (SNAP-D64RS and B-series racks with terminal strips)

Part Number	Description	Width (inches)	Width (mm)	Length (inches)	Length (mm)
SNAP-B8MC SNAP-B8MC-P [OBSOLETE]	8-module rack for other brains, with terminal block	4.41	112.01	9.25	234.95
SNAP-B12MC SNAP-B12MC-P [OBSOLETE]	12-module rack for other brains, with terminal block	4.41	112.01	12.25	311.15
SNAP-B16MC SNAP-B16MC-P [OBSOLETE]	16-module rack for other brains, with terminal block	4.41	112.01	15.25	387.35
SNAP-D64RS [OBSOLETE]	16-module rack, digital only	4.41	112.01	15.25	387.35

DIMENSIONAL DRAWINGS (CONTINUED)

Dimensions—B-Series Racks Without Terminal Strips

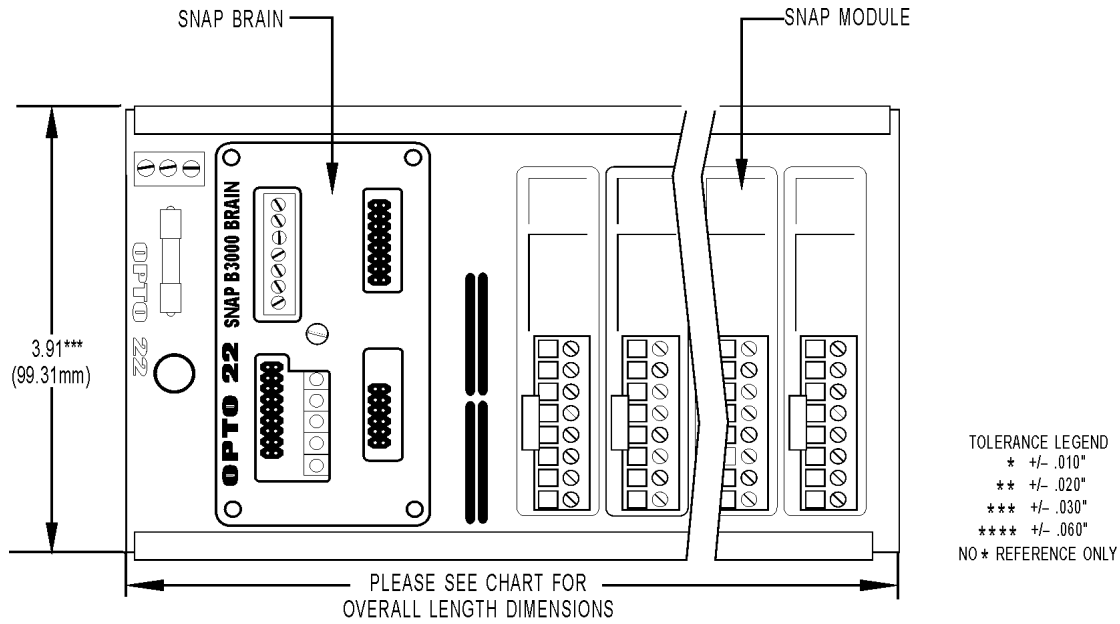

Overall Length Dimensions (B-series racks without terminal strips)

Part Number	Description	Width (inches)	Width (mm)	Length (inches)	Length (mm)
SNAP-B4M	4-module rack	3.91	99.31	6.24	158.41
SNAP-B8M	8-module rack	3.91	99.31	9.24	234.70
SNAP-B12M	12-module rack	3.91	99.31	12.24	310.90
SNAP-B16M	16-module rack	3.91	99.31	15.24	387.10

DIMENSIONAL DRAWINGS (CONTINUED)

SNAP-D64RS [OBSOLETE] Rack and B-Series Racks with Terminal Strips:
Right Side View with DIN-Rail Option Installed

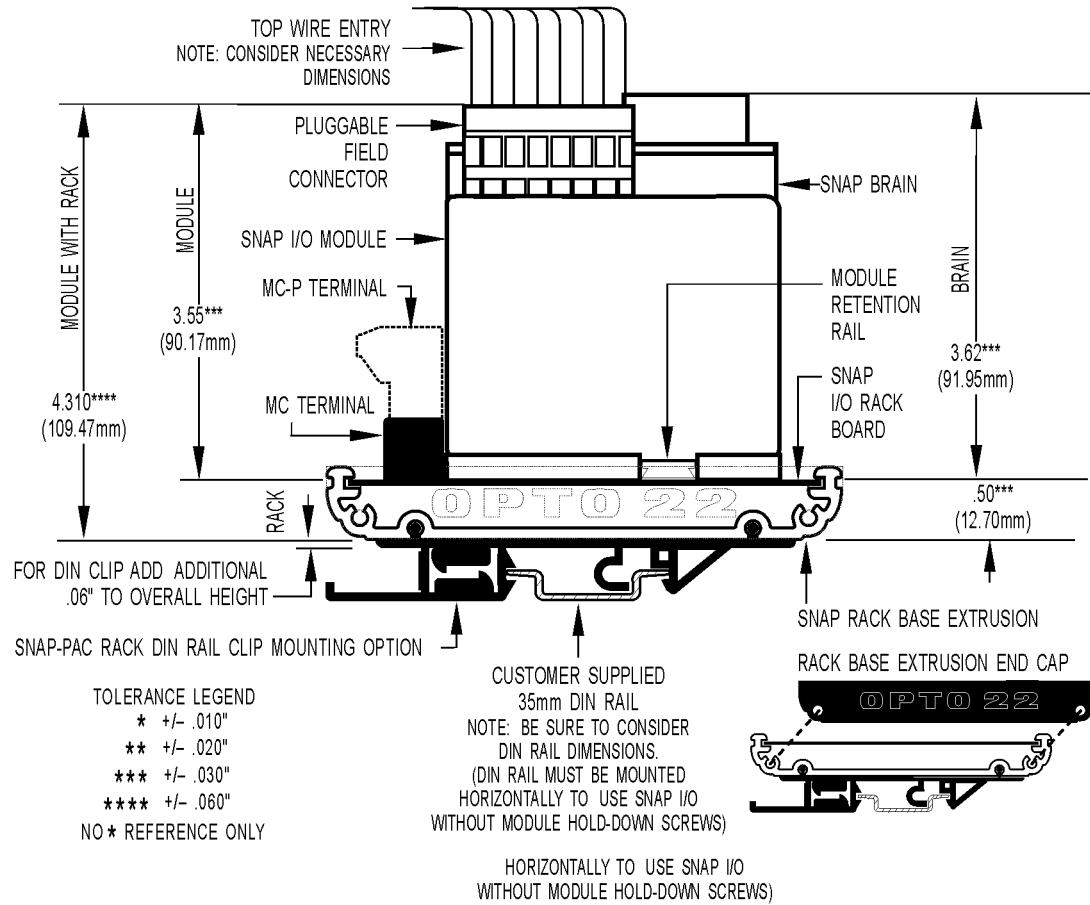

Processor Height*	Processor Part Number	Rack		
4.12 in. (104.6 mm)	SNAP-UP1-ADS	B-series		
	SNAP-B3000-ENET			
	SNAP-ENET-RTC			
3.70 in. (95.9 mm)	SNAP-UP1-D64	SNAP-D64RS		
	SNAP-ENET-D64			
	B3000		B3000-HA	B-series
	SNAP-B4		SNAP-BRS-HA	
SNAP-B6	SNAP-B3000-MODBUS			
	SNAP-BRS			

* Height listed is from the processor's mounting surface to the highest part of the processor. Height does not include wiring or cables.

DIMENSIONAL DRAWINGS (CONTINUED)

B-Series Racks Without Terminal Strips:
Right Side View with DIN-Rail Option Installed

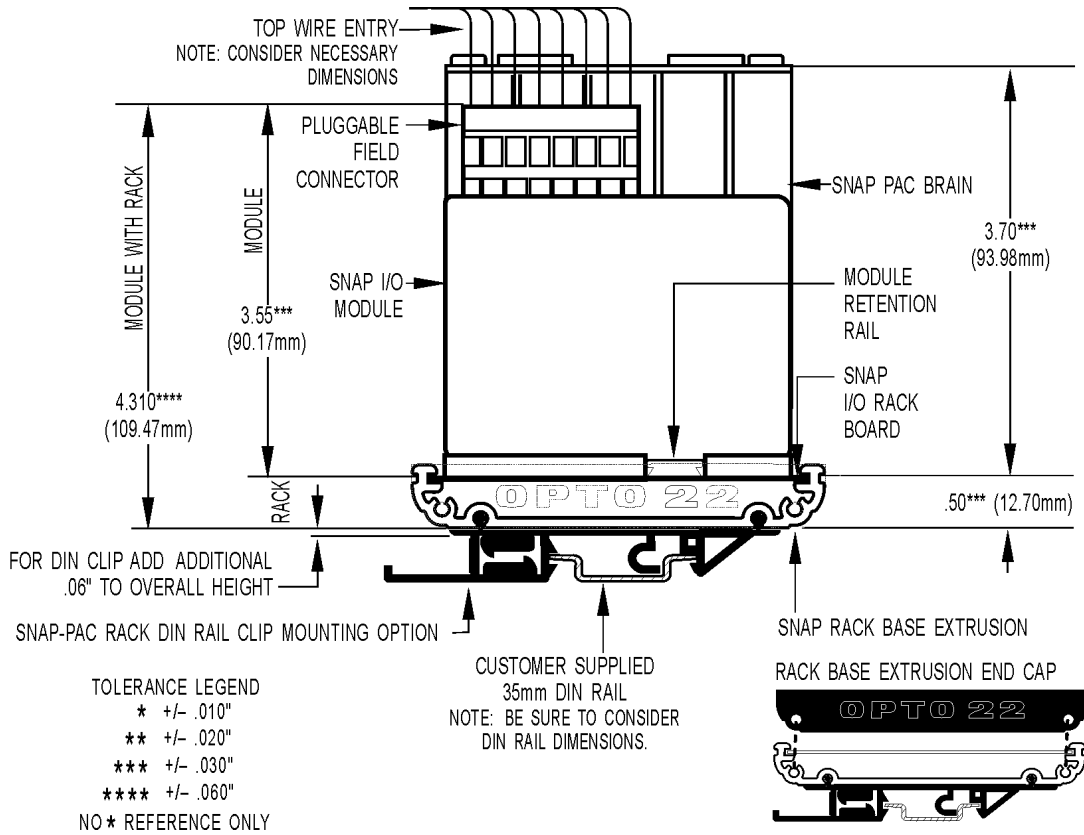

Processor Height*	Processor Part Number	
4.12 in. (104.6 mm)	SNAP-UP1-ADS SNAP-B3000-ENET	SNAP-ENET-RTC
3.70 in. (95.9 mm)	B3000 SNAP-B4 SNAP-B6 B3000-HA	SNAP-BRS SNAP-BRS-HA SNAP-B3000-MODBUS

* Height listed is from the processor's mounting surface to the highest part of the processor. It does not include wiring or cables.

MOUNTING

NOTE: If you are not using hold-down screws, the SNAP rack assembly should be mounted horizontally.

Use the following steps to mount racks as shown in the diagrams on the next two pages.

Preferred Method: Template

(Product on site)

1. Use SNAP rack mounting extrusion as template.
2. Be sure to use the diagrams on the next two pages to determine required product and option clearances.

Alternate Method: Prefabrication of Panels

(No product on site)

Mounting holes are in sets of two, located on lower left and upper right with respect to a center line (CL).

1. Using the diagrams on the next two pages, determine CL1 mounting hole positions. (CL1 is located on the left side of all SNAP rack mounting extrusions.)
2. Use the center-to-center length specification table below to determine the offset between center lines and the number of center line positions for each model.
3. Repeat the process for each center line position.

Center-to-Center Length (All Models)

Part Number	Description	Center-to-Center Length	Number of Center Positions
SNAP-B4M	4-module rack	4.01 in.	2
SNAP-B8M SNAP-B8MC SNAP-B8MC-P [OBSOLETE]	8-module rack	3.51 in.	3
SNAP-B12M SNAP-B12MC SNAP-B12MC-P [OBSOLETE]	12-module rack	5.01 in.	3
SNAP-B16M SNAP-B16MC SNAP-B16MC-P [OBSOLETE] SNAP-D64RS [OBSOLETE]	16-module rack	4.34 in.	4

MOUNTING (CONTINUED)

SNAP-D64RS [OBSOLETE] Rack and B-Series Racks with Terminal Strips:
Typical Plain View of SNAP Mounting Extrusion

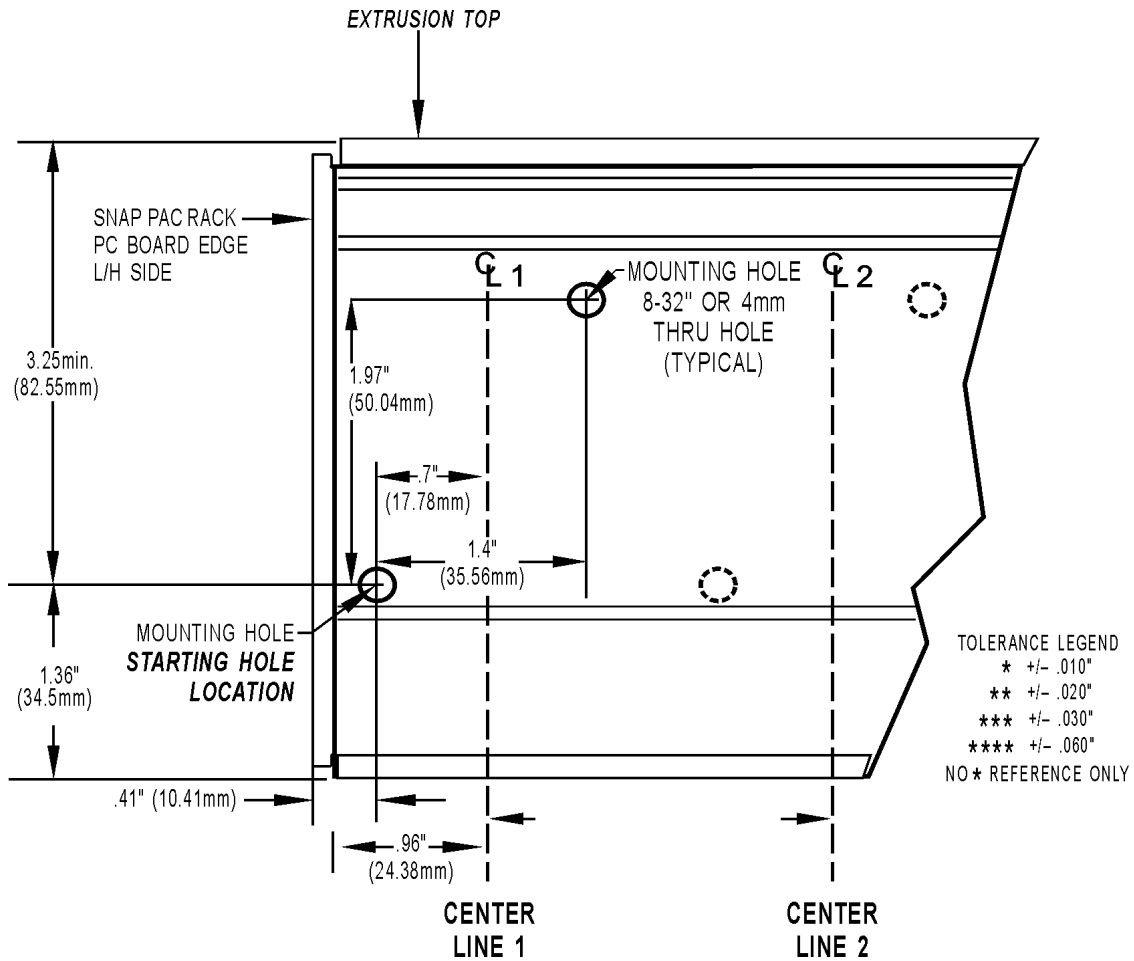

See instructions and table on [page 9](#).

MOUNTING (CONTINUED)

B-Series Racks Without Terminal Strips:
Typical Plain View of SNAP Mounting Extrusion

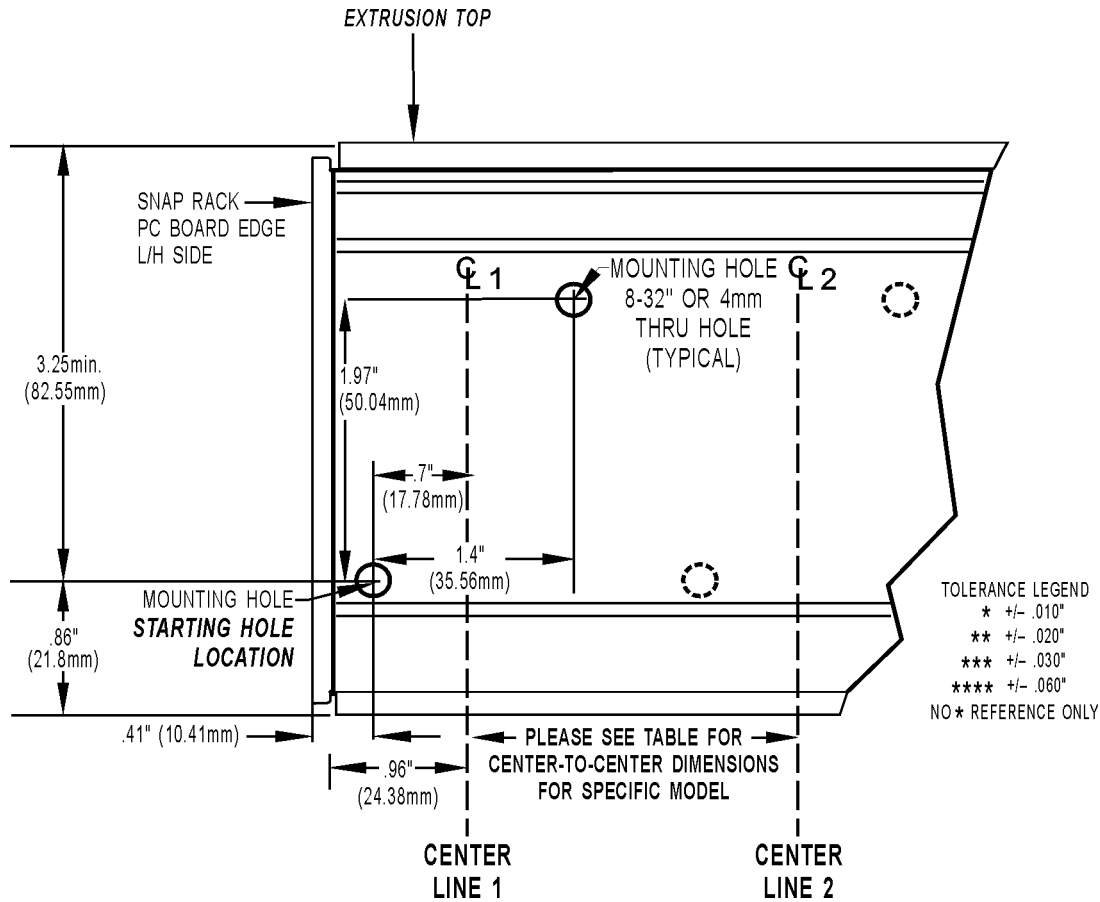

See instructions and table on [page 9](#).

WIRING DIAGRAMS—B-SERIES MODELS WITH TERMINAL STRIPS

Terminal Strip Usage—Digital

NOTE: Consult the SNAP module data sheet for your specific module for additional wiring information.

Example: Digital Input Using Terminal Strip

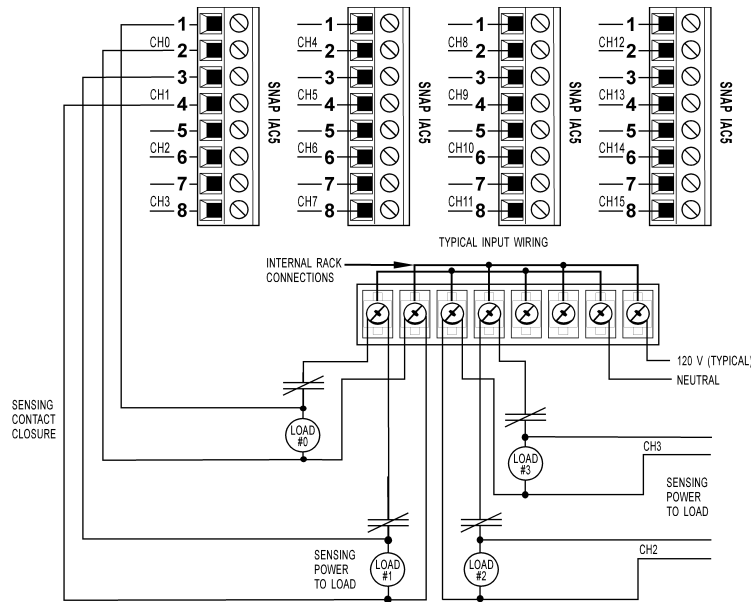

Example: Digital AC Output Using Terminal Strip

TYPICAL WIRING FOR "SNAP OAC5" DIGITAL OUTPUT MODULE ON A FOUR-MODULE SNAP RACK

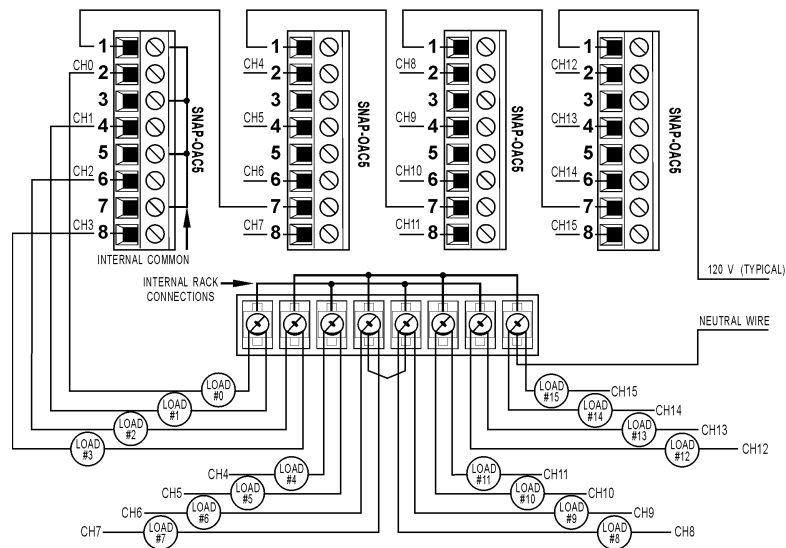

WIRING DIAGRAMS—B-SERIES MODELS WITH TERMINAL STRIPS

Terminal Strip Usage—Digital (continued)

Example: Digital DC Output (Sourcing) Using Terminal Strip

NOTE: Consult the SNAP module data sheet for your specific module for additional wiring information.

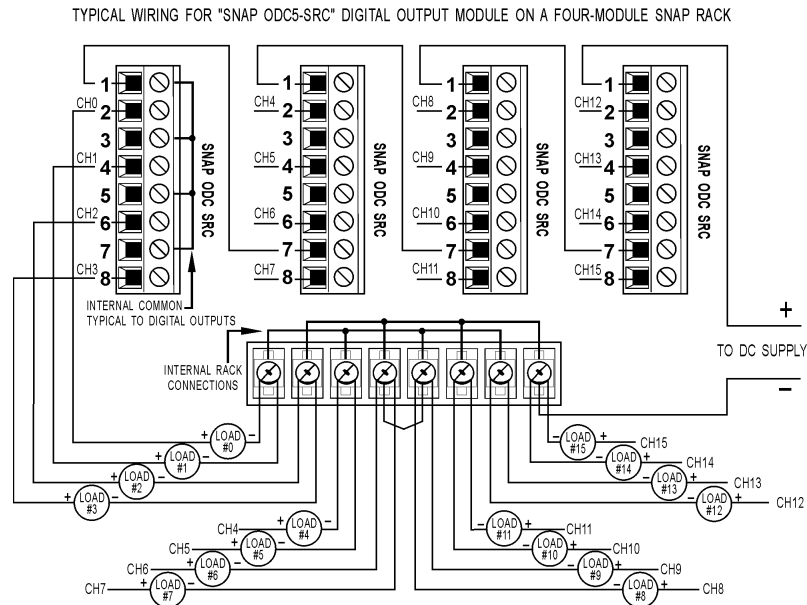

Example: Digital DC Output (Sinking) Using Terminal Strip

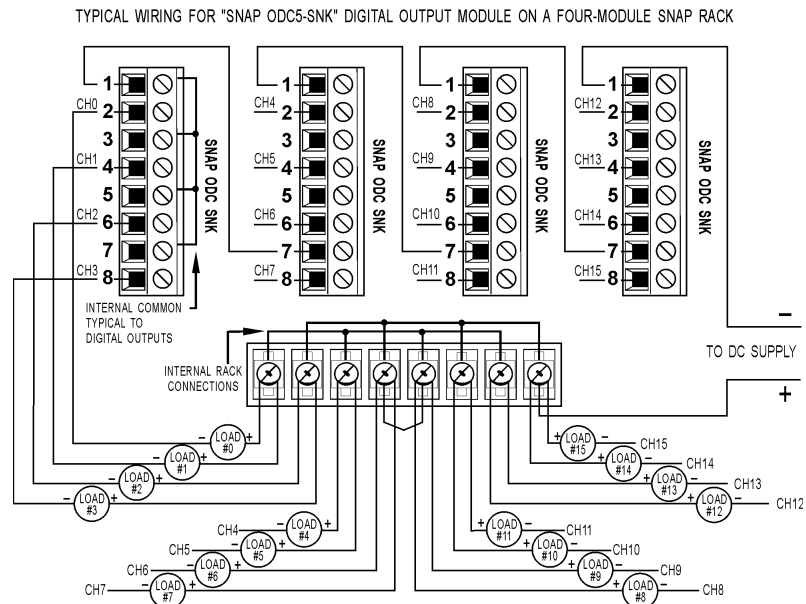

WIRING DIAGRAMS—B-SERIES MODELS WITH TERMINAL STRIPS

Terminal Strip Usage—Analog

NOTE: Consult the SNAP module data sheet for your specific module for additional wiring information.

Example: Analog Input (Current: Negative) Using Terminal Strip

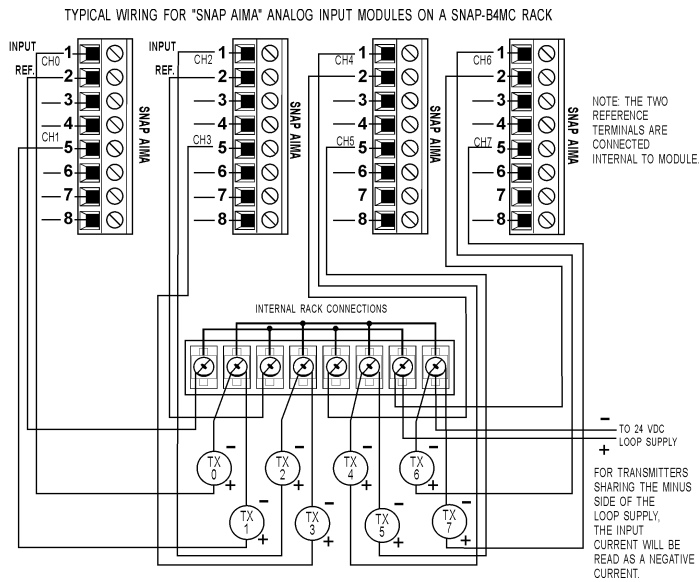

Example: Analog Input (Current: Positive) Using Terminal Strip

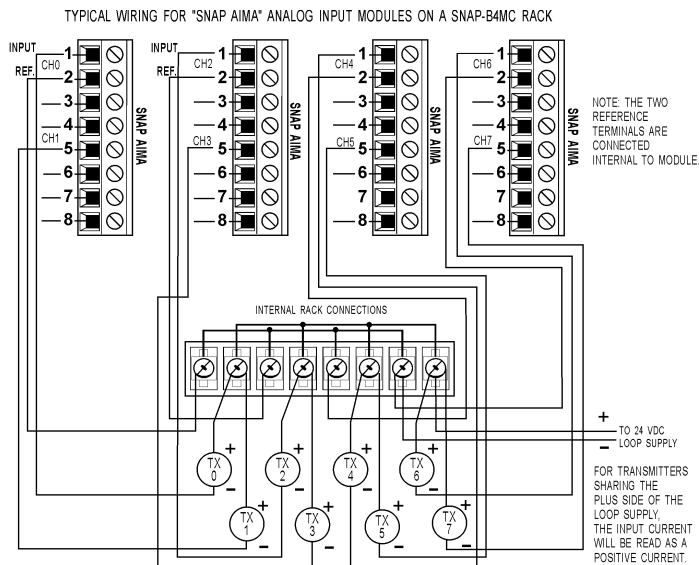

WIRING DIAGRAMS—B-SERIES MODELS WITH TERMINAL STRIPS

Terminal Strip Usage—Analog (continued)

Example: Analog Output (4–20 mA Current: Sourcing) Using Terminal Strip

NOTE: Consult the SNAP module data sheet for your specific module for additional wiring information.

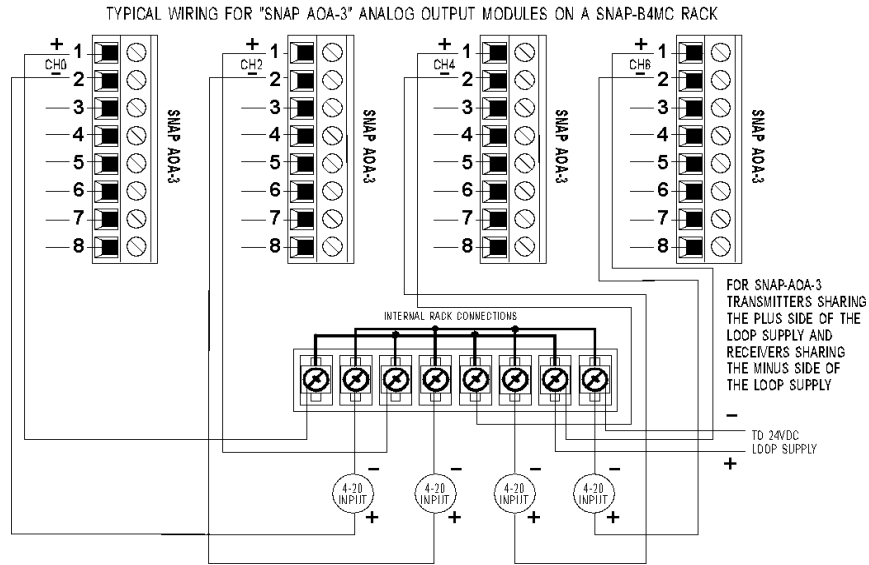

Example: Analog Output (4–20 mA Current: Sinking) Using Terminal Strip

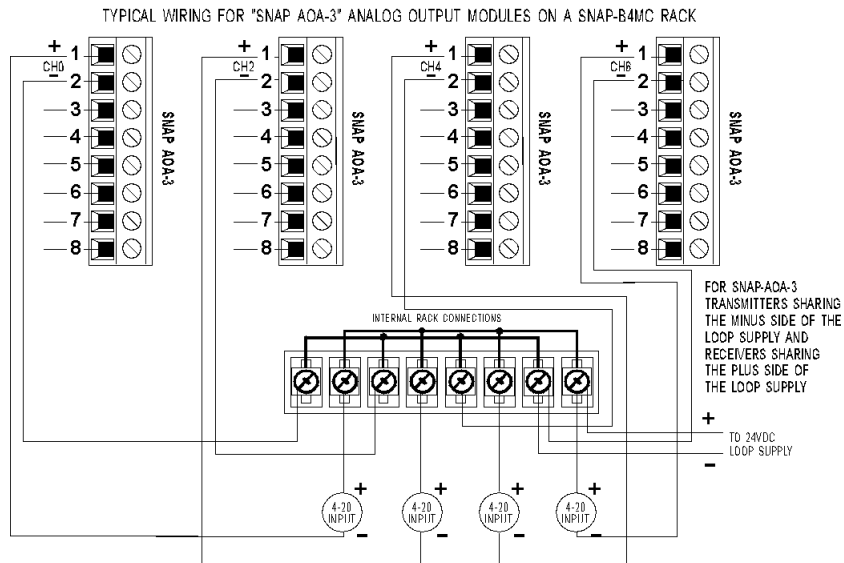

WIRING DIAGRAMS—B-SERIES MODELS WITH TERMINAL STRIPS

Terminal Strip Usage—Analog (continued)

Example: Analog Input (Voltage) Using Terminal Strip

NOTE: Consult the SNAP module data sheet for your specific module for additional wiring information.

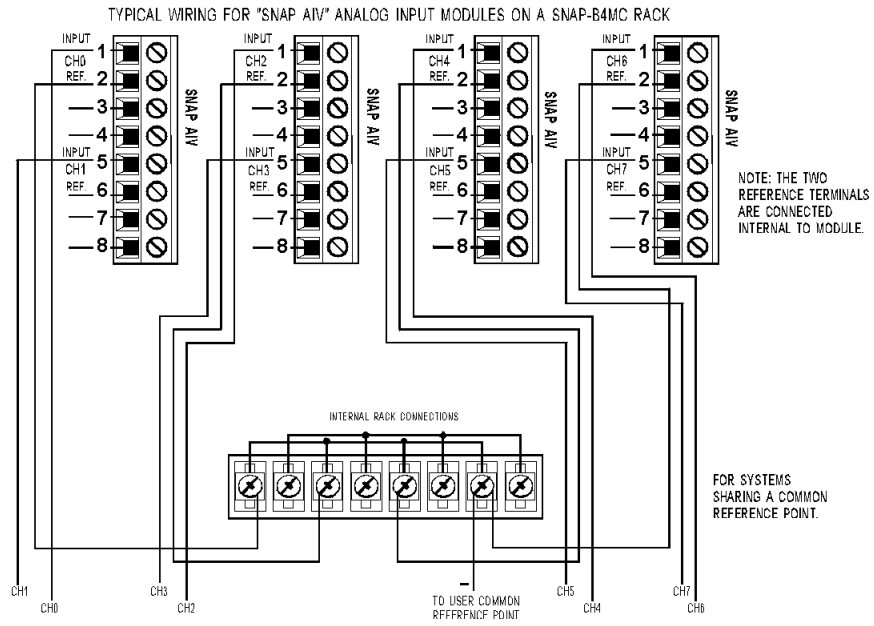

PRODUCTS

Opto 22 develops and manufactures reliable, easy-to-use, open standards-based hardware and software products. Industrial automation, process control, remote monitoring, data acquisition, and industrial internet of things (IIoT) applications worldwide all rely on Opto 22.

groov RIO®

[groov RIO edge I/O](#) offers a single, compact, PoE-powered industrial package with web-based configuration and IIoT software built in, support for multiple OT and IT protocols, and security features like a device firewall, data encryption, and user account control.

Standing alone, *groov* RIO connects to sensors, equipment, and legacy systems, collecting and securely publishing data from field to cloud. Choose a universal I/O model with thousands of possible field I/O configurations, with or without Ignition from Inductive Automation®, or a [RIO EMU energy monitoring unit](#) that reports 64 energy data values from 3-phase loads up to 600 VAC, Delta or Wye.

You can even write an IEC 61131-3 compliant control program to run on *groov* RIO, using CODESYS. You can also use *groov* RIO with a Modbus/TCP master or as remote I/O for a *groov* EPIC system.

groov EPIC® System

Opto 22's [groov Edge Programmable Industrial Controller \(EPIC\) system](#) gives you industrially hardened control with a flexible Linux®-based processor with gateway functions, guaranteed-for-life I/O, and software for your automation and IIoT applications.

groov EPIC Processor

The heart of the system is the *groov* EPIC processor. It handles a wide range of digital, analog, and serial functions for data collection, remote monitoring, process control, and discrete and hybrid manufacturing.

In addition, the EPIC provides secure data communications among physical assets, control systems, software applications, and online services, both on premises and in the cloud. No industrial PC needed.

Configuring and troubleshooting I/O and networking is easier with the EPIC's integrated high-resolution color touchscreen. Authorized users can manage the system locally on the touchscreen, on a monitor connected via the HDMI or USB ports, or on a PC or mobile device with a web browser.

groov EPIC I/O

groov I/O connects locally to sensors and equipment. Modules have a spring-clamp terminal strip, integrated wireway, swing-away cover, and LEDs indicating module health and discrete channel status. *groov* I/O is hot swappable, UL Hazardous Locations approved, and ATEX compliant.

groov EPIC Software

The *groov* EPIC processor comes ready to run the software you need:

- Programming: Choose flowchart-based PAC Control, CODESYS Development System for IEC61131-3 compliant programs, or secure shell access (SSH) to the Linux OS for custom applications
- Node-RED for creating simple IIoT logic flows from pre-built nodes
- Efficient MQTT data communications with string or Sparkplug data formats
- Multiple OPC UA server options
- HMI: *groov* View to build your own HMI viewable on touchscreen, PCs, and mobile devices; PAC Display for a

Windows HMI; Node-RED dashboard UI

- Ignition or Ignition Edge® from Inductive Automation (requires license purchase) with OPC-UA drivers to Allen-Bradley®, Siemens®, and other control systems, and MQTT communications

Older products

From solid state relays, to world-famous G4 and SNAP I/O, to SNAP PAC controllers, older Opto 22 products are still supported and working hard at thousands of installations worldwide. You can count on us for the reliability and service you expect, now and in the future.

QUALITY

Founded in 1974, Opto 22 has established a worldwide reputation for high-quality products. All are made in the U.S.A. at our manufacturing facility in Temecula, California.

Because we test each product twice before it leaves our factory rather than testing a sample of each batch, we can afford to guarantee most solid-state relays and optically isolated I/O modules for life.

FREE PRODUCT SUPPORT

Opto 22's California-based Product Support Group offers free technical support for Opto 22 products from engineers with decades of training and experience. Support is available in English and Spanish by phone or email, Monday–Friday, 7 a.m. to 5 p.m. PST.

Support is always available on our website, including [free online training](#) at OptoU, how-to [videos](#), [user's guides](#), the Opto 22 KnowledgeBase, and [OptoForums](#).

PURCHASING OPTO 22 PRODUCTS

Opto 22 products are sold directly and through a worldwide network of distributors, partners, and system integrators. For more information, contact Opto 22 headquarters at **800-321-6786** (toll-free in the U.S. and Canada) or **+1-951-695-3000**, or visit our website at www.opto22.com.



X-ON Electronics

Largest Supplier of Electrical and Electronic Components

Click to view similar products for [Controller Accessories](#) category:

Click to view products by [Opto 22](#) manufacturer:

Other Similar products are found below :

[1043501](#) [1061701](#) [1088134](#) [1088135](#) [1624092](#) [2200000258](#) [2400195](#) [24679702](#) [26546842](#) [26546843](#) [26546846](#) [26546849](#) [2688129](#)
[2700992](#) [2701182](#) [2701185](#) [2701189](#) [2701190](#) [2701250](#) [2702275](#) [2740850](#) [2860947](#) [2866116](#) [2878599](#) [2885359](#) [2900889](#) [2908739](#)
[2908783](#) [2908788](#) [2913157](#) [2913158](#) [2962463](#) [2981897](#) [2988146](#) [2988162](#) [2988793](#) [3005013](#) [3F88L-CR002C](#) [3G3AX-AL2025](#) [3G3AX-](#)
[CUSBM002-E](#) [3G3AX-EFIB3](#) [3G3AXNFI24](#) [3G3AX-NFO02](#) [3G3AX-OP01](#) [3G3AX-OPCN1](#) [3G3AX-OPCN3](#) [3G3AX-ZCL2](#)
[3RK19042AB02](#) [50073216-08](#) [50073217-08](#)