

■ **Features**

- High Luminous LEDs
- 5mm Round Standard Directivity
- UV Resistant Epoxy
- Fewer Color Diffused Type

■ **Applications**

- Electronic Signs And Signals
- Small Area Illuminations
- Back Lighting
- Other Lighting

■ **Outline Dimension**

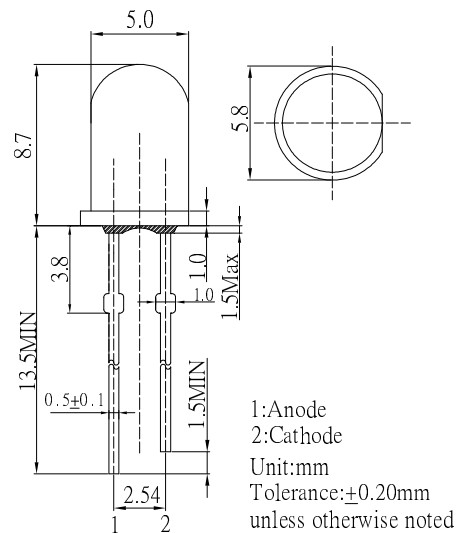

■ **Absolute Maximum Rating (Ta=25°C)**

Item	Symbol	Value	Unit
DC Forward Current	I _F	50	mA
Pulse Forward Current#	I _{FP}	100	mA
Reverse Voltage	V _R	5	V
Power Dissipation	P _D	130	mW
Operating Temperature	T _{opr}	-30 ~ +85	°C
Storage Temperature	T _{stg}	-40 ~ +100	°C
Lead Soldering Temperature	T _{sol}	260°C / 5sec	-

■ **Directivity**

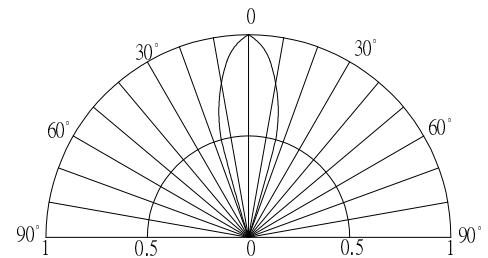

#Pulse width Max.10ms Duty ratio max 1/10

■ **Electrical -Optical Characteristics (Ta=25°C)**

Item	Symbol	Condition	Min.	Typ.	Max.	Unit
DC Forward Voltage*	V _F	I _F =20mA	1.8	2.1	2.6	V
DC Reverse Current	I _R	V _R =5V	-	-	10	μA
Domi. Wavelength*	λ _D	I _F =20mA	600	605	610	nm
Luminous Intensity*	I _v	I _F =20mA	6600	8000	-	mcd
50% Power Angle	2θ _{1/2}	I _F =20mA	-	30	-	deg

*1 Tolerance of measurements of dominant wavelength is ±1nm

*2 Tolerance of measurements of luminous intensity is ±15%

*3 Tolerance of measurements of forward voltage is ±0.1V

AlGaInP LED

TYPICAL ELECTRICAL/OPTICAL CHARACTERISTIC CURVES

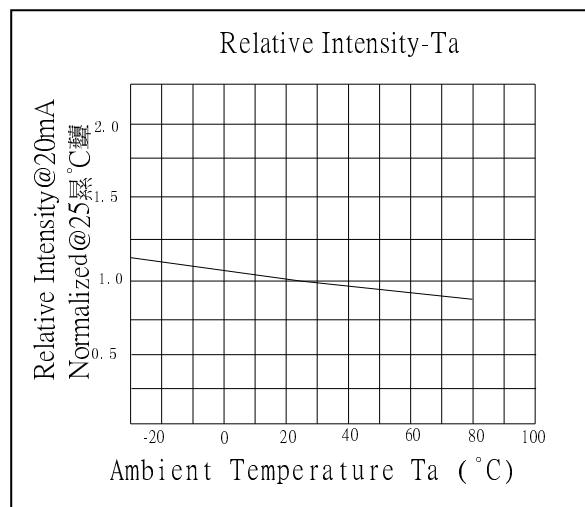
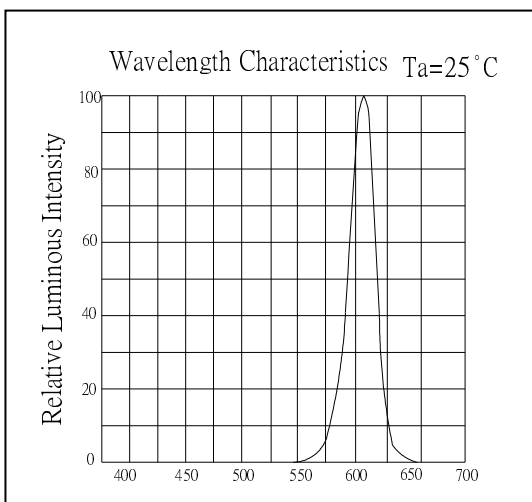
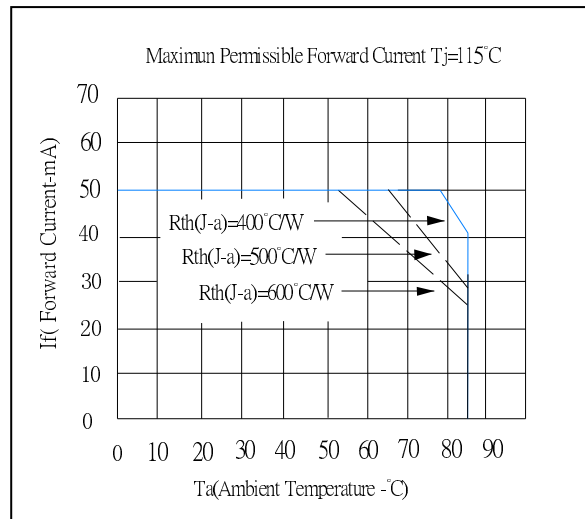
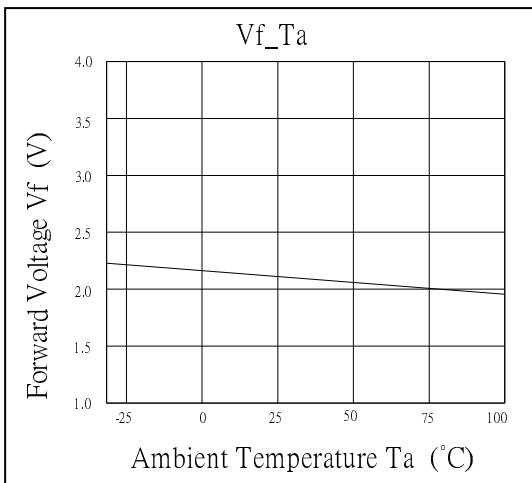
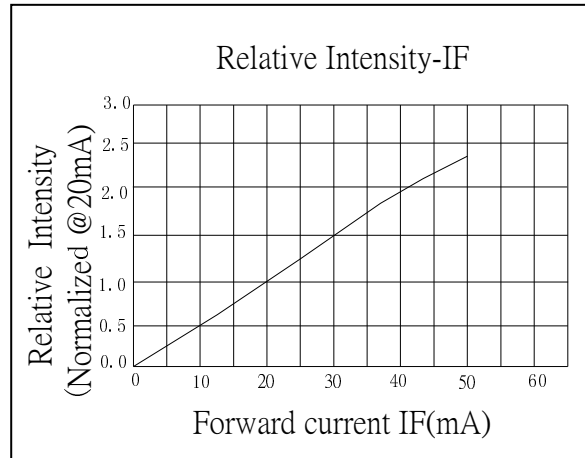
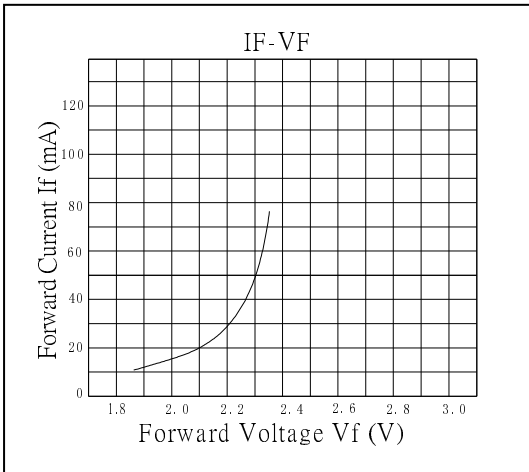

RELIABILITY TEST REPORT

CLASSIFICATION	TEST ITEM	TEST CONDITION
ENDURANCE TEST	ROOM TEMPERATURE OPERATION LIFE	If: 20mA Ta:25±5 °C TEST TIME=1000HRS
	HIGH TEMPERATURE HIGH HUMIDITY STORAGE	R.H:90~95% Ta:65±5°C TEST TIME=240HRS(+2HRS)
	HIGH TEMPERATURE STORAGE	Ta:100°C TEST TIME=500HRS(-24HRS,+48HRS)
	LOW TEMPERATURE STORAGE	Ta:-40°C TEST TIME=500HRS(-24HRS,+48HRS)
ENVIRONMENTAL TEST	TEMPERATURE CYCLING	-40°C ~25°C ~100°C ~25°C 30min 5min 30min 5min 20cycles
	RESISTANCE TO SOLDERING HEAT	Ta:260±5°C TEST TIME=10±1sec
	SOLDERABILITY	Ta:245±5°C TEST TIME=5±1sec

JUDGMENT CRITERIA OF FAILURE FOR THE RELIABILITY

MEASURING ITME	SYMBOL	CONDITIONS	FAILURE CRITERIA
LUMINOUS INTENSITY	IV	IF=20mA	IV<0.5*L.S.L
FORWARD VOLTAGE	VF	IF=20mA	VF>1.2*U.S.L
REVERSE CURRENT	IR	Vr=5V	IR>2*U.S.L
SOLDERABILITY	-	-	LESS THAN 95% SOLDER COVERAGE

U.S.L : Upper Specification Limit

L.S.L : Lower Specification Limit

OPERATION LIFE TEST LUMINANCE RATE CURVE

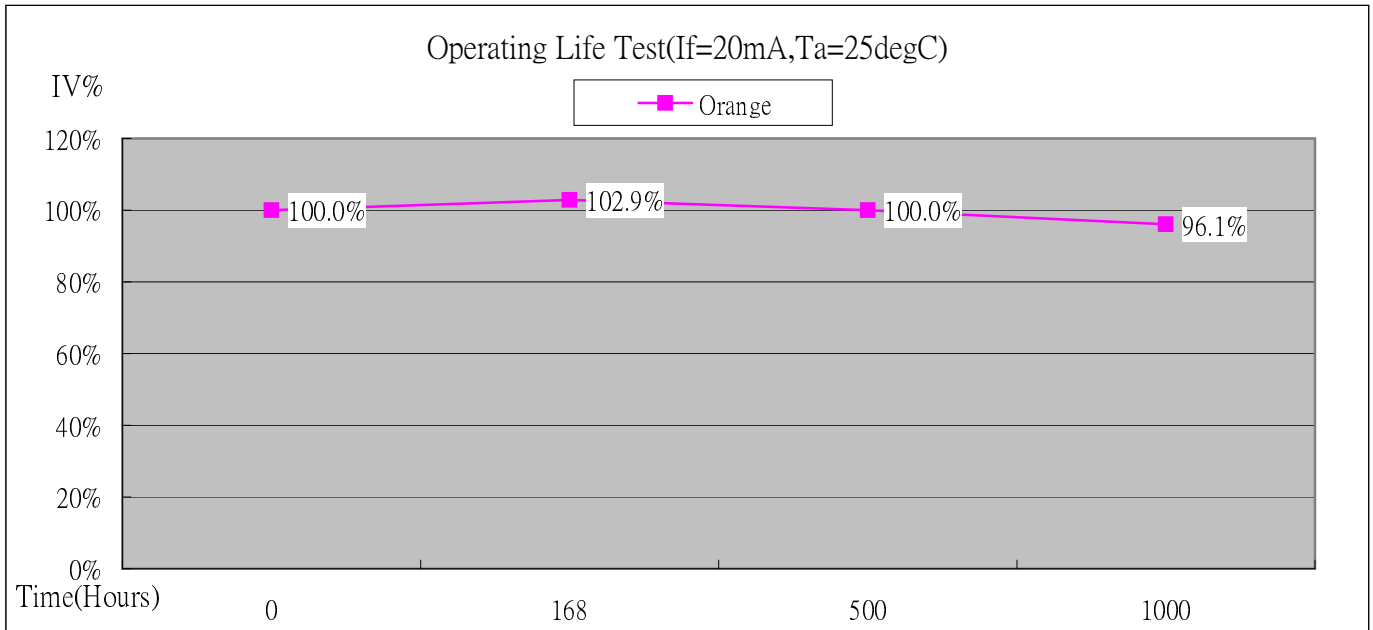

*Burn-in condition: 20mA

*Projection of Statistical Average Light Output Degradation Performance for LED Technology
Extrapolated from OptoSupply QA Dept. Test Data.

*According to OptoSupply outgoing Packaged Products Specification

*MTBF:50,000hrs, 90% Confidence (A Failure is Any LED Which is Open, shorted or fails to Emit Light)

*The Projected Data is Base on The Feature of LED Itself Under Normal Operation Conditions.

*Any Improper Circuit Design or External Factors Might Cause a Different Result.

LAMP APPLICATION (PB FREE SOLDERJING)

Apply to LAMP (DIP) SERIES.

Description:

(1) Manual soldering (Solder Iron)

- (1.1) Temperature at tip of the iron: 350°C Max.
- (1.2) It's banned to load any stress on the resin during soldering.
- (1.3) Soldering time: 3sec.Max.(one time only.)
- (1.4) Leave 3mm of minimum distance from the base of the epoxy.

(2) Dip Soldering (Wave Soldering-Solder Bath)

- (2.1) Leave 3mm of minimum distance from the base of the epoxy.
Soldering beyond the base of the tie bar (stand off) is recommended.
- (2.2) When soldering, do not put stress on the LEDs during heating.
- (2.3) Cutting the lead frames at high temperatures may cause LED failure.
- (2.4) Never take next process until the component is cooled down to room temperature after reflow.
- (2.5) After soldering, do not warp the circuit board.
- (2.6) The recommended dip soldering profile is the following.

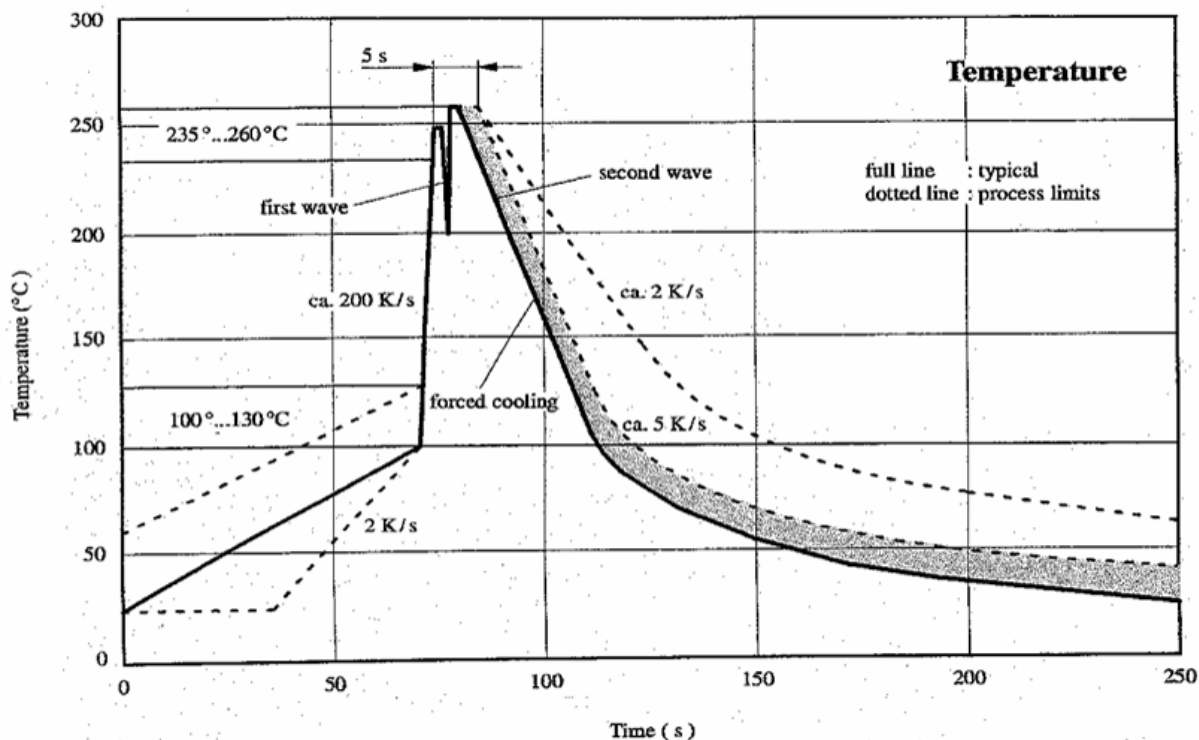

Wave soldering of double wave optodevices

LAMP PACKING

500pcs/Bag

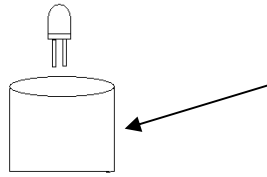

LED LAMPS	
PART NO:	_____
LOT NO:	_____
IV:	_____
VF:	_____
COLOR:	_____
QTY:	_____
QC:	_____

BOX
Dimension (mm)
396*305*324
40Bags/Box

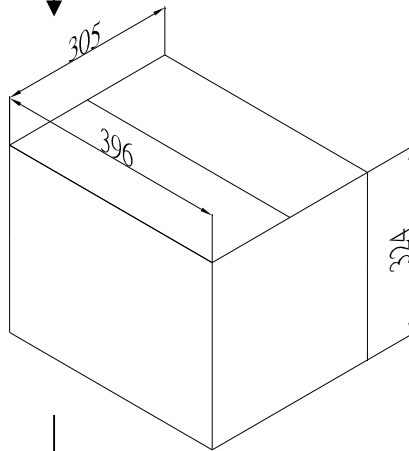

Carton
Dimension (mm)
675*410*320
2Boxes/Carton

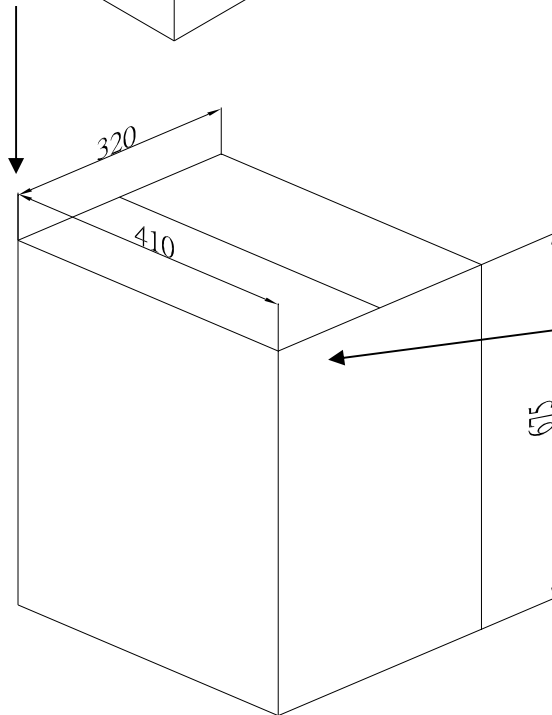

LED LAMPS	
PART NO:	_____
LOT NO:	_____
IV:	_____
VF:	_____
COLOR:	_____
QTY:	_____
QC:	_____

X-ON Electronics

Largest Supplier of Electrical and Electronic Components

Click to view similar products for [Optosupply](#) manufacturer:

Other Similar products are found below :

[OSB5SA5111A-CRLED16](#) [OSB5SA83C1A](#) [OSX10201-YGR1](#) [OS5YKP5111A](#) [OS5YPM8131A](#) [OS5YAA5HA4D-1-ST](#) [OS6OGA5B61P](#)
[OSW5DK5A31A-CRLED18](#) [OSY5PA5A31A-1MA](#) [OSB4YU39B4B](#) [OSO5JA3FE1B-12V](#) [OKLEDT30606A](#) [OSPT9054X3A](#)
[OKLEDT5050RPW](#) [OSL10564-IB](#) [OSO5PA58A1B-12V](#) [OKLEDT8050G5W](#) [OKLEDT8050RPW](#) [OSGGD251A5A](#) [OKLEDT3050RBW](#)
[OSYYP251A5A](#) [OKLEDT5050B5W](#) [OSB5DA3HA1F](#) [OSYBP2A131A](#) [OKLEDT3050RBV](#) [OKLEDT3050WAW](#) [OSL12306-16-IRA](#)
[OSY5MP5A34A-6.8HZ](#) [OKLEDT5050RBV](#) [OKLEDT8050RBV](#) [OKLEDT3050RPW](#) [OKLEDT5050WAV](#) [OSWRP23962B](#)
[OKLEDT5050TAW](#) [OKLEDT8050G5V](#) [OKLEDT8050WAW](#) [OSY5MSA131A](#) [OSXD2201-AGA](#) [OKLEDT3050RPV](#) [OKLEDT5050RBW](#)
[OSL10601-IRA](#) [OSCM4TS4C1A](#) [OSM5XAHEE1E](#) [OS6OGA3131P](#) [OSL10564-IYG](#) [OSO5PA56A1A-CRLED14](#) [OSRGH23NE2A](#)
[OST1MCA132A](#) [OKLEDT31206A](#) [OSPTYJ53X2T](#)