

Photo-Coupler	
THD Type:	PS817
SMD Type:	PS817-SMD

Features

- Current transfer ratio (CTR: MIN. 50% at $I_F=5\text{mA}$, $V_{CE}=5\text{V}$)
- High input-output isolation voltage ($V_{ISO}=5,000\text{Vrms}$)
- Response time (t_r : TYP. $4\mu\text{s}$ at $V_{CE}=2\text{V}$, $I_C=2\text{mA}$, $R_L=100\ \Omega$)
- CQC approved
- UL approved
- CSA approved

Description

- The 817 series are optically coupled isolators containing a GaAs light emitting diode and an NPN silicon phototransistor
- The lead pitch is 2.54mm

Applications

1. Computer terminals.
2. System appliances, measuring instruments.
3. Registers, copiers, automatic vending machines.
4. Electric home appliances, such as fan heaters, etc.
5. Signal transmission between circuits of different potentials and impedances.

Outline Dimensions

PS817

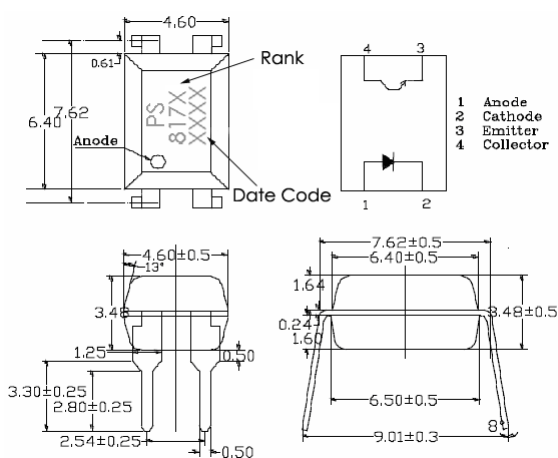

PS817-SMD

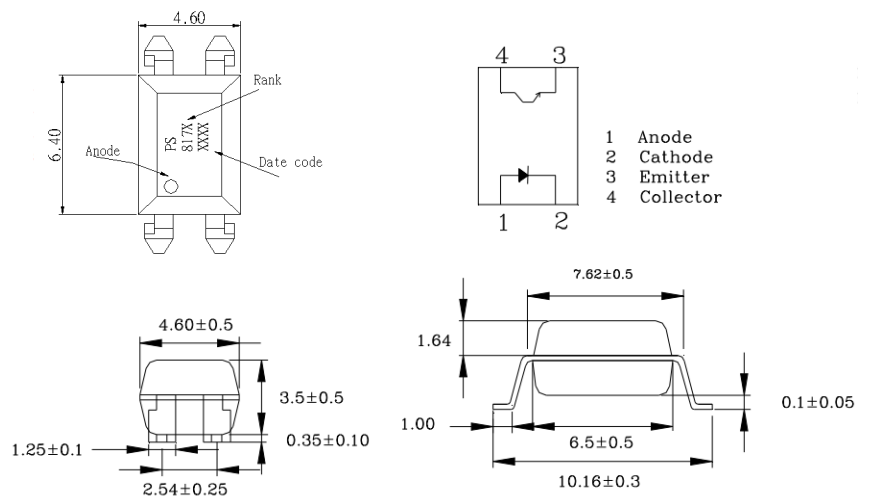

Photo-Coupler	
THD Type:	PS817
SMD Type:	PS817-SMD

Absolute Maximum Ratings (Ta=25°C)

Parameter		Symbol	Rating	Unit
INPUT	Forward Current	I _F	50	mA
	Reverse Voltage	V _R	6	V
	Power Dissipation	P	70	mW
OUTPUT	Collector-Emitter Voltage	V _{CEO}	70	V
	Emitter-Collector Voltage	V _{ECO}	6	V
	Collector Current	I _C	50	mA
	Collector Power Dissipation	P _C	150	mW
	Total Power Dissipation	P _{tot}	200	mW
Isolation Voltage (Note 1)		V _{iso}	5,000	V _{rms}
Operating Temperature		T _{opr}	-30 to + 100	°C
Storage Temperature		T _{stg}	-55 to + 125	
Soldering Temperature(Note 2)		T _{sol}	260	

Note:

1. AC for 1 minute, R.H. =40~60%

Isolation voltage shall be measured using the following method:

- (a) Short between anode and cathode on the primary side and between collector and emitter on the secondary side
- (b) The waveform of applied voltage shall be a sine wave

2. For 10 Seconds

Electrical and Optical Characteristics (Ta=25°C)

Parameter		Symbol	Conditions	MIN.	TYP.	MAX	Unit
INPUT	Forward Voltage	V _F	IF=20mA	---	1.2	1.4	V
	Reverse Current	I _R	VR=4V	---	---	10	μA
	Terminal Capacitance	C _t	V=0, f=1KHz	---	30	250	pF
OUTPUT	Collector Dark Current	I _{CEO}	VCE=20V, IF=0	---	---	100	nA
	Collector-Emitter Breakdown Voltage	BV _{CEO}	IC=0.1mA IF=0	70	100	---	V
	Emitter-Collector Breakdown Voltage	BV _{ECO}	IE=10μA IF=0	6	9	---	V
	Collector Current 2	I _c	IF=5mA VCE=5V	2.5	---	30	mA
	Current Transfer Ratio 2 (Note 1)	CTR	130	---	400	%	

Photo-Coupler	
THD Type:	PS817
SMD Type:	PS817-SMD

Collector-Emitter Saturation Voltage	$V_{CE(sat)}$	IF=20mA IC=1mA	---	0.1	0.2	V
Isolation Resistance	R_{iso}	DC500V 40~60%R.H.	5×10^{10}	1×10^{11}	---	Ω
Floating Capacitance	C_f	V=0, f=1MHz	---	0.6	1	pF
Cut-Off Frequency	f_c	VCE=5V, IC=2mA RL=100 Ω , -3dB	---	80	---	kHz
Response Time(Rise)	t_r	VCE=2V, IC=2mA RL=100 Ω	---	4	18	μ s
Response Time(Fall)	t_f		---	3	18	μ s

Note:

1. $CTR = IC / IF \times 100\%$

Rank Table of Current Transfer Ratio (CTR)

(Conditions: IF=5mA, VCE=5V, Ta=25°C.)

RANK MARK	Min. (%)	Max. (%)
B	130	260
C	200	400

Reliability Test

Classification	Test Item	Reference Standard	Test Conditions	Result
Endurance Test	Operation Life	MIL-STD-750:1026 MIL-STD-883:1005 JIS C 7021 :B-1	Connect with a power If=50mA Ta=Under room temperature Test time=1,000hrs	0/20
	High Temperature High Humidity Reverse Bias (H3TRB)	JIS C 7021 :B-11	Ta=+85°C \pm 5°C, RH=85% PTR=VCE absolute max rating*80% Test time=1000hrs	0/20
	High Temperature Reverse Bias (HTRB)	JIS C 7021 :B-8	Ta=+105°C \pm 5°C PTR=VCE absolute max rating Test time=1000hrs	0/20
	High Temperature Storage	MIL-STD-883:1008 JIS C 7021 :B-10	High Ta=+125°C \pm 5°C Test time=1,000hrs	0/20

Photo-Coupler	
THD Type:	PS817
SMD Type:	PS817-SMD

	Low Temperature Storage	JIS-C-7021 :B-12	Low Ta=-55℃±5℃ Test time=1,000hrs	0/20
	Autoclave	JESD 22-A102-B	P=15PSIG, Ta=121℃ Humi. =100%RH, 48hrs	0/20
Environmental Test	Temperature Cycling	MIL-STD-202:107D MIL-STD-750:1051 MIL-STD-883:1010 JIS C 7021 :A-4	125℃ ~ 25℃ ~ -55℃ ~ 25℃ 30min 5min 30min 5min Test Time=20cycle	0/20
	Thermal Shock	MIL-STD-202:107D MIL-STD-750:1051 MIL-STD-883:1011	125℃ ~ -55℃ 20min 20min Test Time=20cycle	0/20
	Solder Resistance	MIL-STD-202:201A MIL-STD-750:2031 JIS C 7021 :A-1	Operation heating: 260℃, within 10±1seconds	0/20
	Solder Ability	MIL-S-883:2003 JIS C 7021 :A-2	Operation heating: 235℃, within 5±1seconds.	0/20

Judgment Criteria of Failure for the Reliability

Symbol	Measuring conditions	Judgment criteria for failure
V _F (V)	I _F =50mA	Over Ux1.0
I _r (uA)	V _r =5V	Over Ux1.0
CTR(%)	I _F =5mA, V _{CE} =5V	Shift>1.2
V _{CE(sat)}	I _F =20mA, I _C = 1mA	Over Ux1.0
BV _{CEO}	I _C =0.1mA, I _F =0	Over Lx1.0
BV _{ECO}	I _E =10μA, I _F =0	Over Lx1.0

Photo-Coupler	
THD Type:	PS817
SMD Type:	PS817-SMD

Characteristics Curves

Fig.1 Forward Current vs. Ambient Temperature

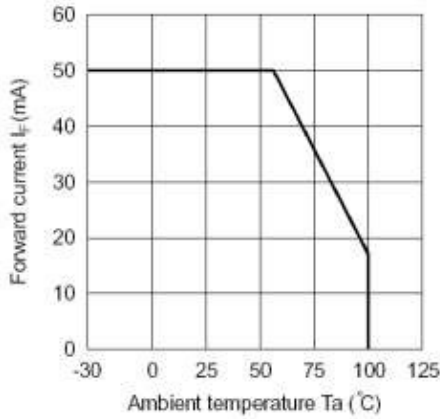

Fig.2 Collector Power Dissipation vs. Ambient Temperature

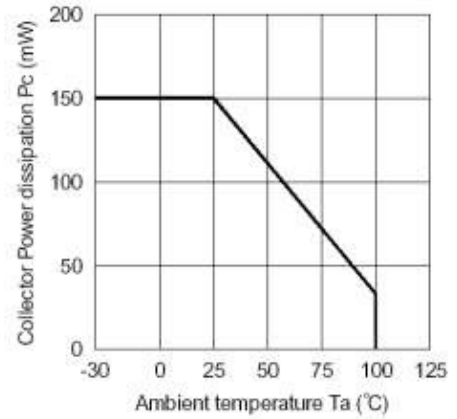

Fig.3 Collector-emitter Saturation Voltage vs. Forward Current

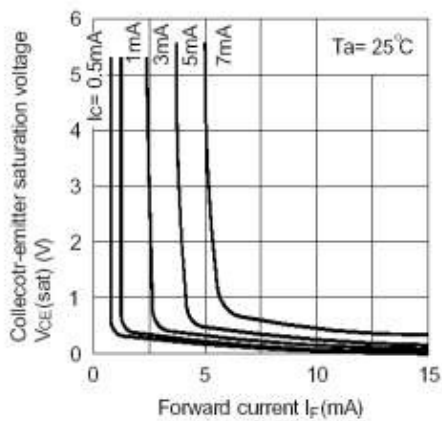

Fig.4 Forward Current vs. Forward Voltage

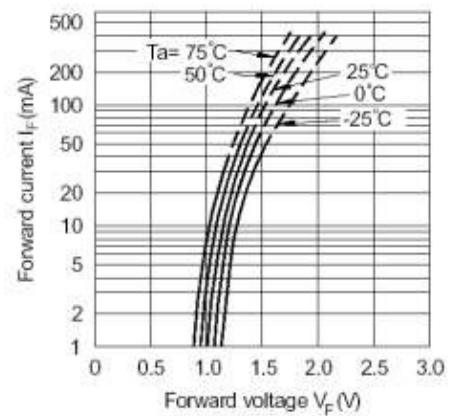

Fig.5 Current Transfer Ratio vs. Forward Current

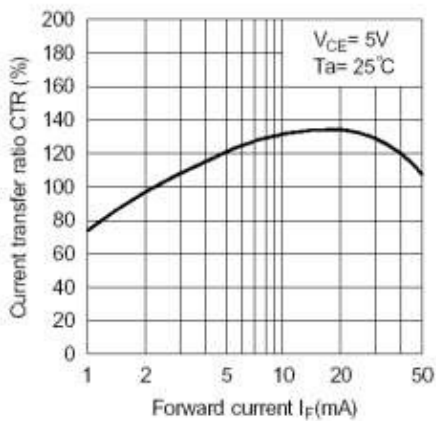

Fig.6 Collector Current vs. Collector-emitter Voltage

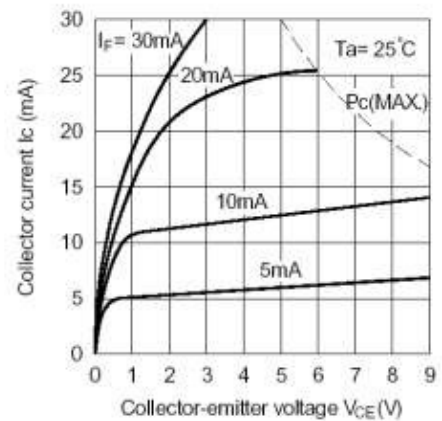

Photo-Coupler	
THD Type:	PS817
SMD Type:	PS817-SMD

Fig.7 Relative Current Transfer Ratio vs. Ambient Temperature

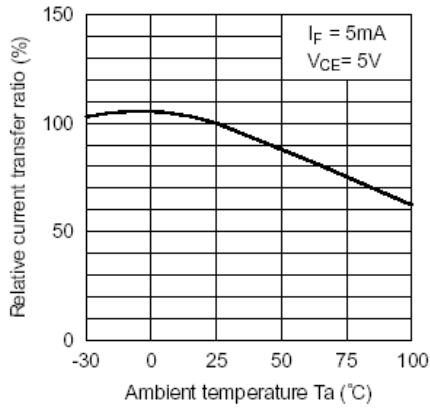

Fig.8 Collector-emitter Saturation Voltage vs. Ambient Temperature

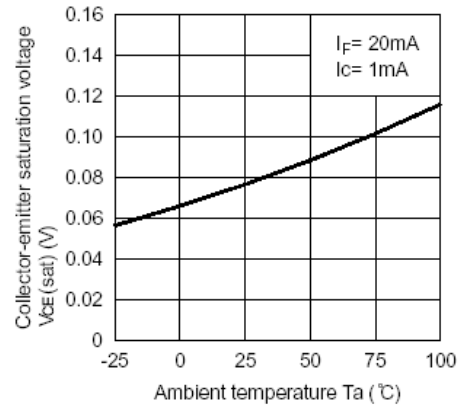

Fig.9 Collector Dark Current vs. Ambient Temperature

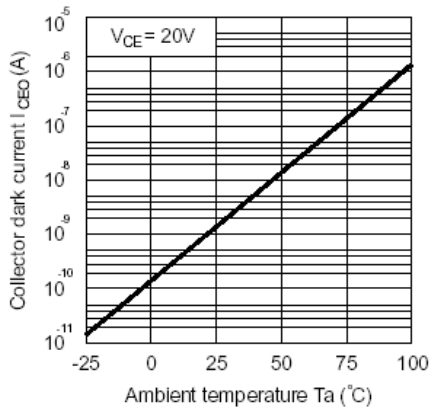

Fig.10 Response Time vs. Load Resistance

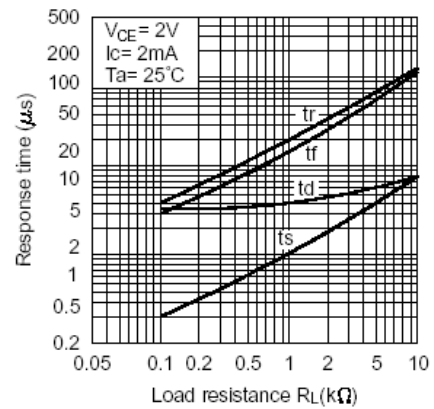
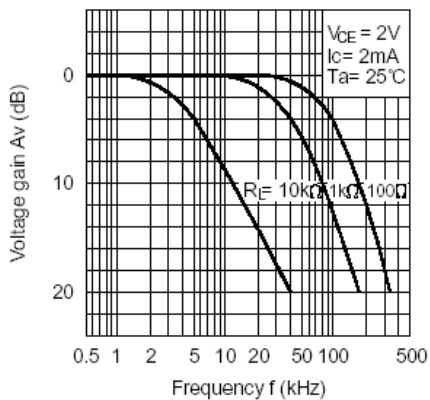
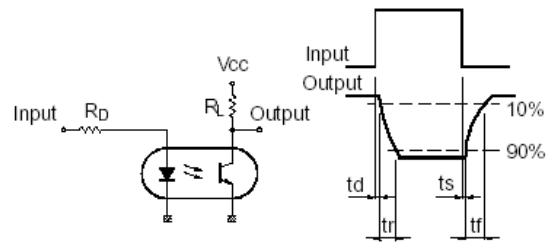

Fig.11 Frequency Response



Test Circuit for Response Time



Test Circuit for Frequency Response

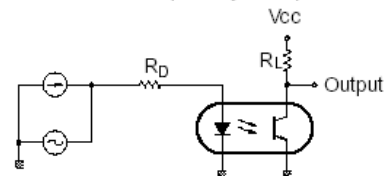

Photo-Coupler	
THD Type:	PS817
SMD Type:	PS817-SMD

Packing Information

Model: PS817

Packing Type: Tube

A. Dimensions of tube for dip type(Units: mm)

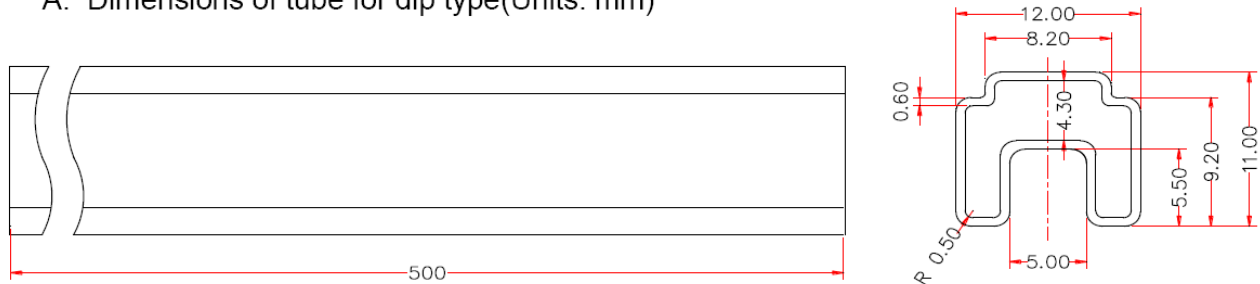

B. Inner Carton (Units: mm)

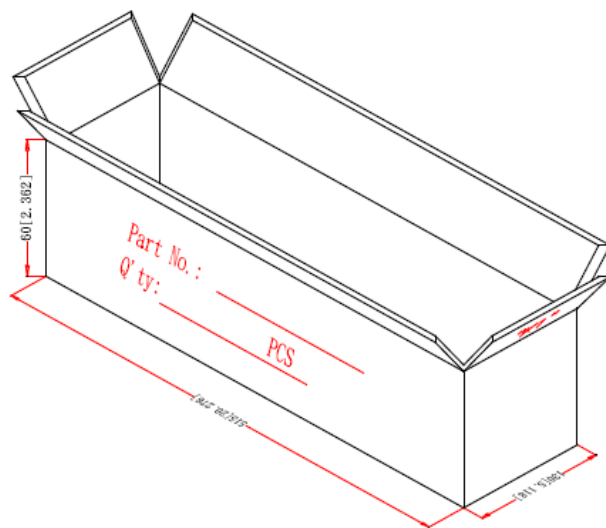

C. Outside Carton(Units: mm)

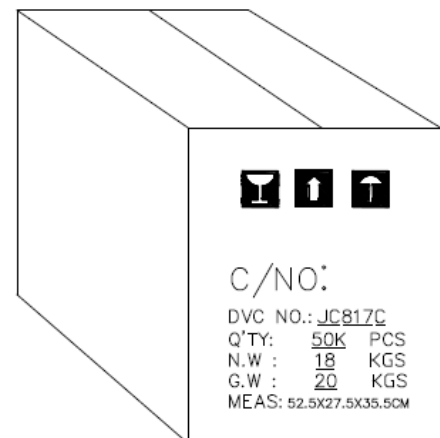

D. Packing Quantity

100 pcs per Tube;

50 Tubes per Inner Carton;

10 Inner Cartons per Outside Carton

Photo-Coupler	
THD Type:	PS817
SMD Type:	PS817-SMD

Packing Information

Model: PS817-SMD

Packing Type: Tape & Reel

A. Dimensions of Reel

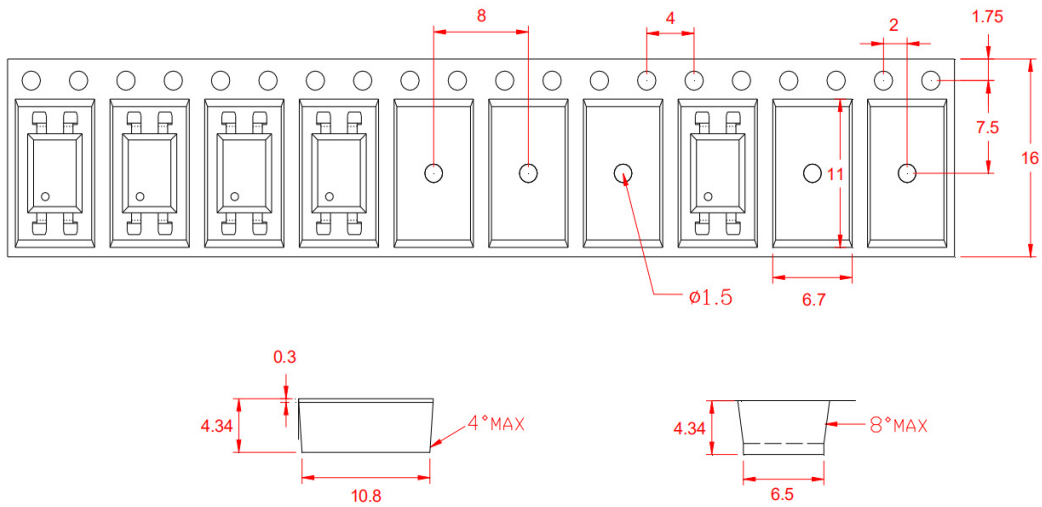

B. Dimensions of Tape

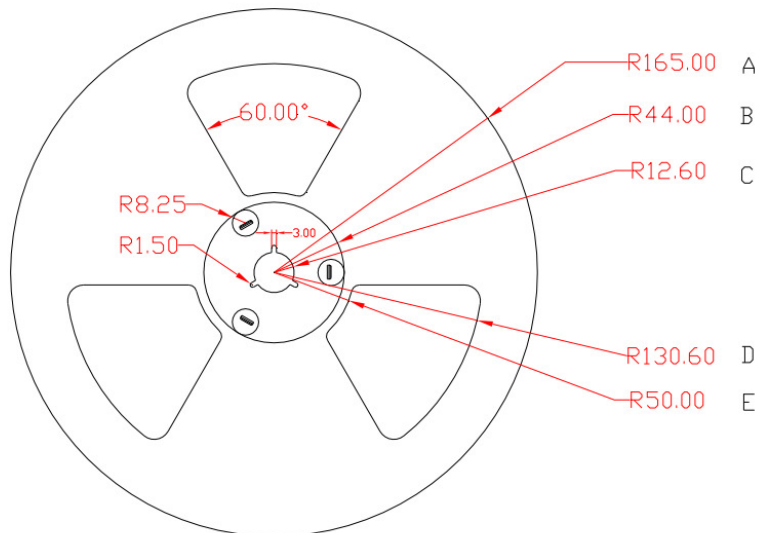

C. Packing Quantity

- 2 Kpcs per Reel;
- 3 Reel per Inner Carton;
- 5 Inner Carton per Outside Carton

X-ON Electronics

Largest Supplier of Electrical and Electronic Components

Click to view similar products for [Transistor Output Optocouplers](#) category:

Click to view products by [Optosupply](#) manufacturer:

Other Similar products are found below :

[LTV-814S-TA](#) [LTV-824HS](#) [LTV-852S](#) [66095-001](#) [MCT6-X007](#) [MOC8101-X017T](#) [PS2561-1-A](#) [PS2561A-1-W-A](#) [PS2561B-1-L-A](#)
[PS2561L-1-V-A](#) [MRF658](#) [IL755-1X007](#) [ILD74-X001](#) [ILQ615-3X016](#) [LDA102S](#) [LDA110S](#) [SFH615AGR-X007T](#) [PS2561-1-V-W-A](#)
[PS2561AL-1-V-A](#) [PS2561L1-1-L-A](#) [PS2701A-1-F3-P-A](#) [PS2801-1-F3-P-A](#) [PS2911-1-L-AX](#) [CNY17-4X001](#) [CNY17-4X017](#) [CNY17F-](#)
[1X007](#) [CNY17F-2X017](#) [CNY17F-4X001](#) [CNY17G-1](#) [LTV-214](#) [LTV-702V](#) [LTV-702VB](#) [LTV-733S](#) [LTV-816S-TA](#) [LTV-825S](#) [TCET2100](#)
[4N25-X007T](#) [IL215AT](#) [ILD615-1X007](#) [ILQ2-X007](#) [VOS615A-2T](#) [WPPC-A11066AA](#) [WPPC-A11066AD](#) [WPPC-A11084ASS](#) [WPPC-](#)
[A21068AA](#) [WPPC-D11066AA](#) [WPPC-D21068ED](#) [WPPC-D410616EA](#) [WPPC-D410616ED](#) [X4IAC24A](#)