



ORIENT

Photo coupler

Product Data Sheet

Part Number: OR-0631

Customer: _____

Date: _____

SHENZHEN ORIENT COMPONENTS CO., LTD

Block A 3rd Floor No.4 Building, Tian'an Cyber Park, Huangge Rd, LongGang Dist, Shenzhen, GD

TEL: 0755-29681816

FAX: 0755-29681200

www.orient-opto.com

1. Features

- (1) High speed 10Mbit/s.
- (1) 10kV/μs minimum common mode transient immunity at VCM= 1KV.
- (2) Wide operating temperature range of -40°C to 105°C.
- (3) Logic gate output.
- (4) High isolation voltage between input and output(Viso=3750 V rms).
- (5) Safety approval
 - UL approved(No.E323844)
 - VDE approved(No.40029733)
 - CQC approved (No.CQC19001231254)
- (6) In compliance with RoHS, REACH standards
- (7) MSL Level 1

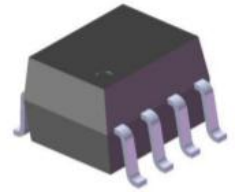

2. Instructions

The OR-0631 devices each consists of an infrared emitting diode optically coupled to a high speed integrated photo detector logic gate with a strobable output.

The devices are packaged in an 8-pin small outline package which conforms to the standard SO8 footprint.

3. Application Range

- (1)Ground loop elimination
- (2)LSTTL to TTL, LSTTL or 5 volt CMOS
- (3)Line receiver, data transmission
- (4)Data multiplexing
- (5)Switching power supplies
- (6)Pulse transformer replacement
- (7)Computer peripheral interface
- (8)High speed logic ground isolation

4. Functional Diagram

Schematic

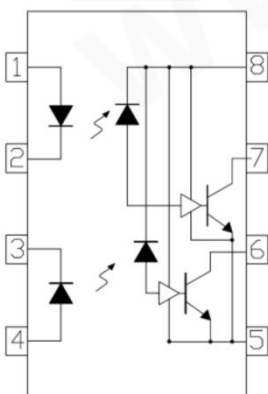

Pin Configuration

- 1. Anode
- 2. Cathode
- 3. Cathode
- 4. Anode
- 5. Gnd
- 6. Vout 2
- 7. Vout 1
- 8. VCC

Truth Table (Positive Logic)

Input	Output
H	L
L	H

5. Absolute Maximum Ratings (Ta=25°C)*1

Parameter		Symbol	Rated Value	Unit
Input	Average Forward Input Current	I_F	15	mA
	Reverse Input Voltage	V_R	5	V
	Power Dissipation	P_I	40	mW
Output	Output Collector Current	I_O	50	mA
	Output Collector Voltage	V_O	7	V
	Output Collector Power Dissipation	P_O	60	mW
Supply Voltage		V_{CC}	7	V
Insulation Voltage		V_{iso}	3750	Vrms
Working Temperature		T_{opr}	-40 ~ +105	°C
Storage Temperature		T_{stg}	-55 ~ +125	
*2 Soldering Temperature		T_{sol}	260	

*1 AC for 1 minute, R.H.= 40 ~ 60% R.H. In this test, pins 1, 2, 3, 4 are shorted together, and pins 5, 6, 7, 8 are shorted together.

*2. soldering time is 10 seconds.

6. Recommended Operating Conditions

Parameter	Symbol	Min.	Max.	Units
Input Current Low Level	I_{FL}	0	250	μA
Input Current High Level	I_{FH}	5	15	mA
Power Supply Voltage	V_{CC}	4.5	5.5	V
Low Level Enable Voltage	V_{EL}	0	0.8	V
High Level Enable Voltage	V_{EH}	2.0	V_{CC}	V
Operating Temperature	T_A	-40	105	°C
Fan Out (at $R_L = 1\text{ k}$)	N	—	5	TTL Loads
Output Pull-up Resistor	R_L	330	4000	

7. Opto-electronic Characteristics

Over recommended temperature ($T_A = -40^{\circ}\text{C}$ to $+85^{\circ}\text{C}$) unless otherwise specified. All Typicals at $V_{CC} = 5\text{V}$, $T_A = 25^{\circ}\text{C}$. All enable test conditions apply to single channel products only.

	Parameter	Symbol	Min	Typ	Max	Unit	Condition
Input	Forward Voltage	V_F	—	—	1.8	V	$I_F = 10\text{mA}$
	Temperature Coefficient OF Forward Voltage	$\Delta V_F / \Delta T$	—	-1.5	—	mV/ $^{\circ}\text{C}$	$I_F = 10\text{mA}$
	Reverse Voltage	BV_R	5	—	—	V	$I_R = 10\mu\text{A}$
	Input Threshold Current	I_{TH}	—	2.7	5	mA	$V_{CC} = 5.5\text{V}$ $V_O = 0.6\text{V}$ $I_{OL}(\text{sinking}) = 13\text{mA}$
	Input Capacitance	C_{IN}	—	60	—	pF	$f = 1\text{MHz}$, $V_F = 0\text{V}$
Detector	High Level Supply Current	I_{CCH}	—	13	18	mA	$V_{CC} = 5.5\text{V}$, $I_F = 0\text{mA}$
	Low Level Supply Current	I_{CCL}	—	15	21	mA	$V_{CC} = 5.5\text{V}$, $I_F = 10\text{mA}$
	High Level Output Current	I_{OH}	—	1	100	μA	$V_{CC} = 5.5\text{V}$ $V_O = 5.5\text{V}$ $I_F = 250\mu\text{A}$
	Low Level Output Voltage	V_{OL}	—	0.27	0.6	V	$V_{CC} = 5.5\text{V}$ $I_F = 5\text{mA}$ $I_{OL}(\text{Sinking}) = 13\text{mA}$

8. Switching Characteristics

Over recommended temperature ($T_A = -40^{\circ}\text{C}$ to $+85^{\circ}\text{C}$) unless otherwise specified. All Typical at $V_{CC} = 5\text{V}$, $T_A = 25^{\circ}\text{C}$. All enable test conditions apply to single channel products only.

Parameter	Symbol	Min	Typ	Max	Unit	Condition
Propagation delay time to output High level	t_{PLH}	25	44	90	ns	$R_L=350\Omega$ $C_L=15\text{pF}$
Propagation delay time to output Low level	t_{PHL}	25	24	75	ns	
Pulse Width Distortion	$ t_{PLH}-t_{PHL} $	—	18	—	ns	
Output Rise Time (10 to 90%)	t_r	—	29	—	ns	
Output Fall Time (90 to 10%)	t_f	—	3	—	ns	

Parameter	Symbol	Min	Typ	Max	Unit	Condition
Logic High Common Mode Transient Immunity	$ CM_H $	10	15	—	kV/ μs	$V_{CC}=5\text{V}, V_{CM}=1000\text{V},$ $R_L=350\Omega, V_{O(MIN)}=2\text{V},$ $I_F=0\text{mA}, T_A=25^{\circ}\text{C}$
Logic Low Common Mode Transient Immunity	$ CM_L $	10	15	—		$V_{CC}=5\text{V}, I_F=7.5\text{mA},$ $V_{O(MIN)}=0.8\text{V}, V_{CM}=1000\text{V},$ $R_L=350\Omega, T_A=25^{\circ}\text{C}$

9. Order Information

Part Number

OR-0631-Y-Z

Note

0631 = Part Number.

Y = Tape and reel option (TA,TA1 or none).

Z = 'V' code for VDE safety (This options is not necessary).

* VDE Code can be selected.

Option	Description	Packing quantity
TA	Surface mount lead form (low profile) + TA tape & reel option	2000 units per reel
TA1	Surface mount lead form (low profile) + TA1 tape & reel option	2000 units per reel

10. Naming Rule

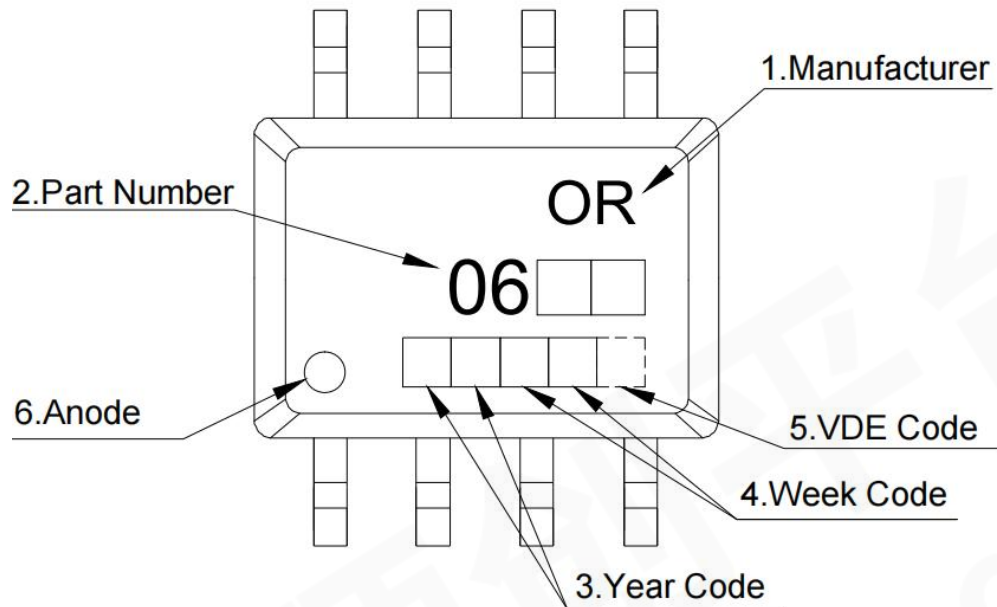

1. Manufacturer : ORIENT.
2. Part Number : 0631.
3. Year Code : '21' means '2021' and so on.
4. Week Code : 01 means the first week, 02 means the second week and so on.
5. Anode.

* VDE Mark can be selected.

11. Outer Dimension

OR-06XX

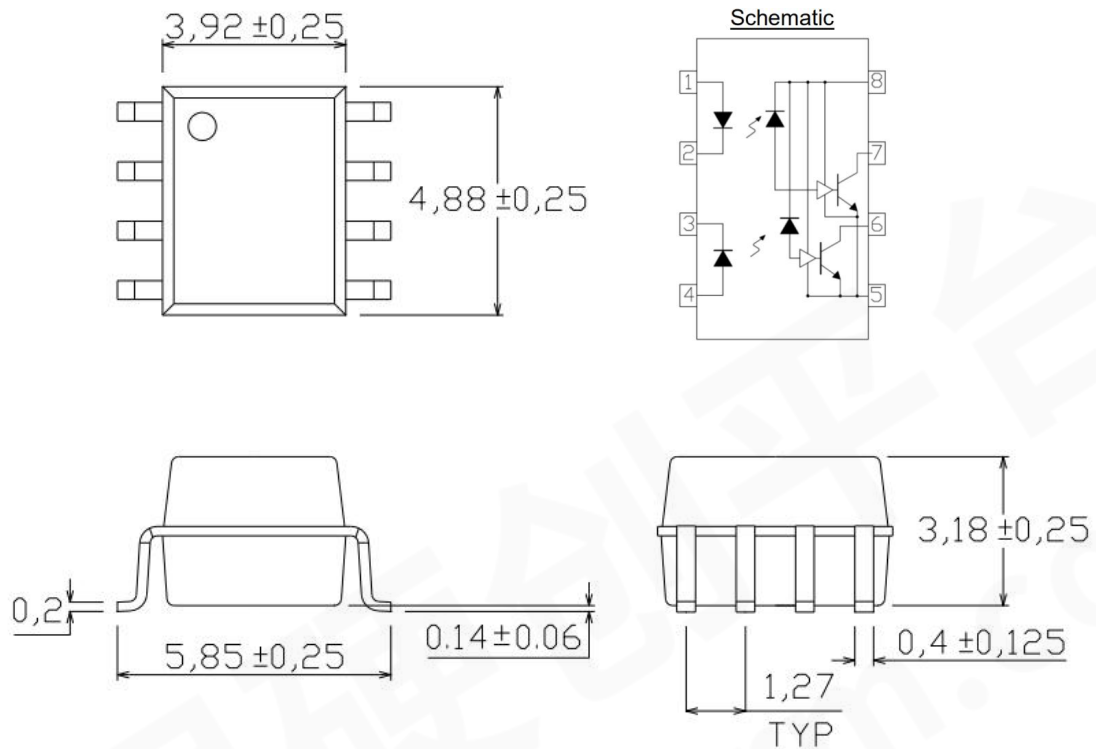

12. Recommended Foot Print Patterns (Mount Pad)

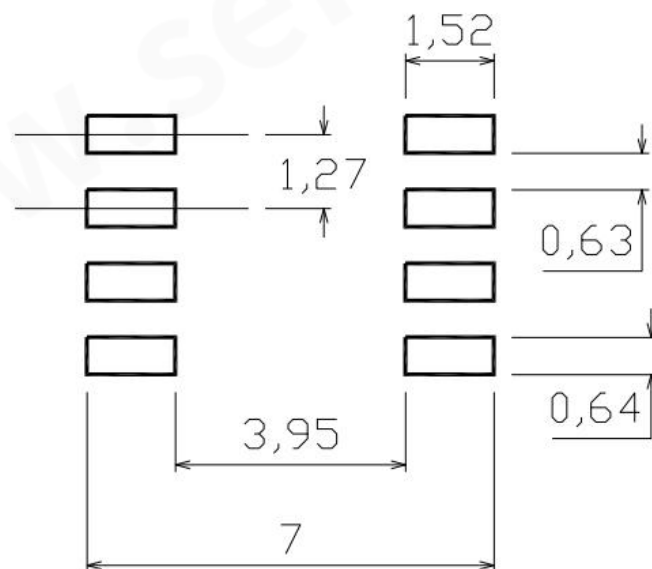

unit: mm

12. Taping Dimensions

(1)OR-06XX-TA1

(2)OR-06XX-TA

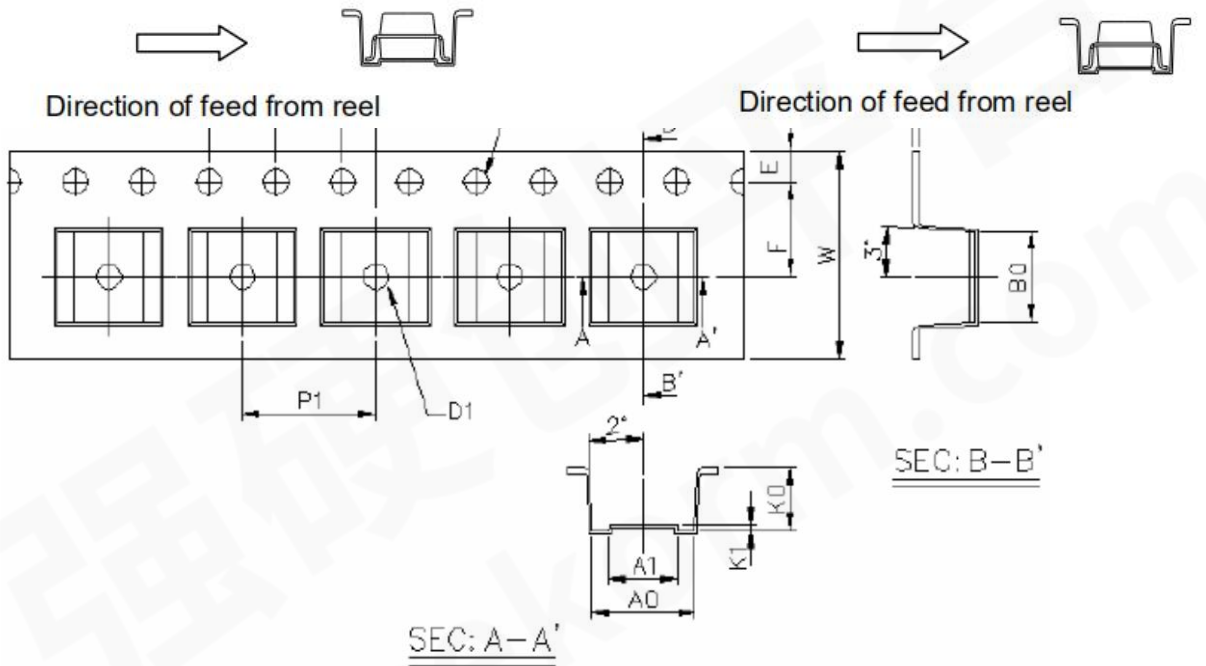
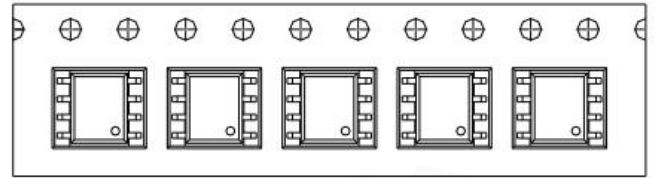
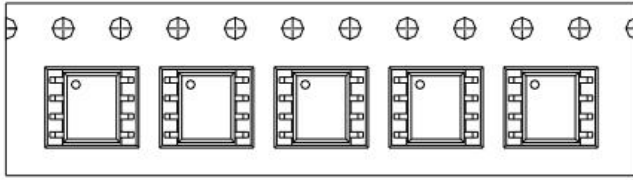

Dimension No.	A0	A1	B0	D0	D1	E	F
Dimension(mm)	6.2±0.1	4.1±0.1	5.28±0.1	1.5±0.1	1.5±0.3	1.75±0.1	5.5±0.1
Dimension No.	Po	P1	P2	t	W	K0	K1
Dimension(mm)	4.0±0.1	8.0±0.1	2.0±0.1	0.4±0.1	12.0+0.3/ -0.1	3.7±0.1	0.3±0.1

Encapsulation type	TA1/TA
amount (pcs)	2000

13. Package Dimension

(1) package dimension

Packing Information	
Packing type	Reel type
Tape Width	12mm
Qty per Reel	2,000pcs
Small box (inner) Dimension	345*345*45mm
Large box (Outer) Dimension	480x360x360mm
Max qty per small box	4,000pcs
Max qty per large box	40,000pcs

(2)Packing Label Sample







Material Code : 120PCXXXXXX
 P/N : OR-XXXXXX
 Lot No. : XXXXXX-XXXXX-TX-X
 D/C : XXXX
 Qty : XXXX PCS

内箱码 外箱码

“XXXXXXXXXXXXXXXXXX” (一体机序列码)
 Made in China

Note:

1. Material Code :Product ID.
2. P/N :Contents with "Order Information" in the specification.
3. Lot No. :Product data.
4. D/C :Product weeks.
5. Quantity :Packaging quantity.

14. Reliability Test

NO.	ITEMS	Reliability Testing				
		QTY. (Pcs)	Condition	Process	Device	Standard
1	RSH 耐焊接热	22	260±5°C	5s/3 次	锡炉	JESD22-A106
2	HTSL 高温存储	77	125°C	168 hrs	高温烤箱 测试仪	JESD22-A103
				500 hrs		
				1000 hrs		
3	LTSL 低温存储	77	-40°C	168 hrs	低温箱 测试仪	JESD22-A119
				500 hrs		
				1000 hrs		
4	TC 温度循环	77	H:125°C 15min ↓5min L:-55°C 15min	300 cycle	冷热冲击 机	JESD22-A104
5	TS 温度冲击	77	H:100°C 5min ↓15s L:-40°C 5min	300 cycle	冷热冲击 机	JESD22-A106
6	HTOL 高温操作	77	100°C IF=10mA Vcc=5V	168 hrs	高温烤箱 测试仪、 老化电路 板	JESD22-A108
				500 hrs		
				1000 hrs		
7	ESD- HBM 人体模式	22	≥8KV 1Cycle	1次	ESD静电 测试仪	JESD22-A114
8	SD 可焊性	22	Pb-free 245±5°C	5s/1次	锡炉	JESD22-B102
9	HTHB 温湿寿命 试验	77	85°C,85%RH IF=10mA,Vcc=5V	168 hrs	恒温恒湿 机, 测试 仪	JESD22-A101
				500 hrs		
				1000 hrs		
10	Autoclave 压力锅	77	Ta=121 °C,100%RH,2atm	96hrs	压力锅	JESD22-A102

15. Temperature Profile Of Soldering

(1) IR Reflow soldering (JEDEC-STD-020C compliant)

Note: one solder backflow is recommended under the conditions described below in the temperature and time profile. Do not weld more than three times.

Profile item	Conditions
Preheat - Temperature Min (T Smin) - Temperature Max (T Smax) - Time (min to max) (ts)	150°C 200°C 90±30 sec
Soldering zone - Temperature (TL) - Time (t L)	217°C 60 sec
Peak Temperature	260°C
Peak Temperature time	20 sec
Ramp-up rate	3°C / sec max.
Ramp-down rate from peak temperature	3~6°C / sec
Reflow times	≤3

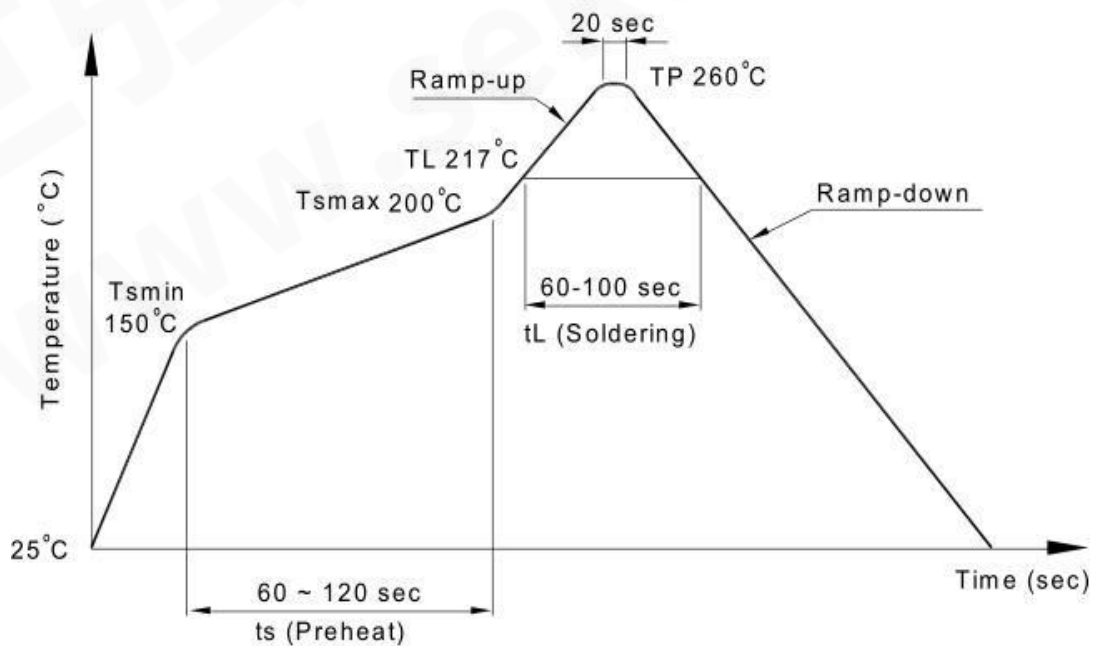

(2) Wave soldering (JEDEC22A111 compliant)

One-time welding is recommended under the temperature condition.

Temperature	260+0/-5°C
Time	10 sec
Preheat temperature	5 to 140°C
Preheat time	30 to 80 sec

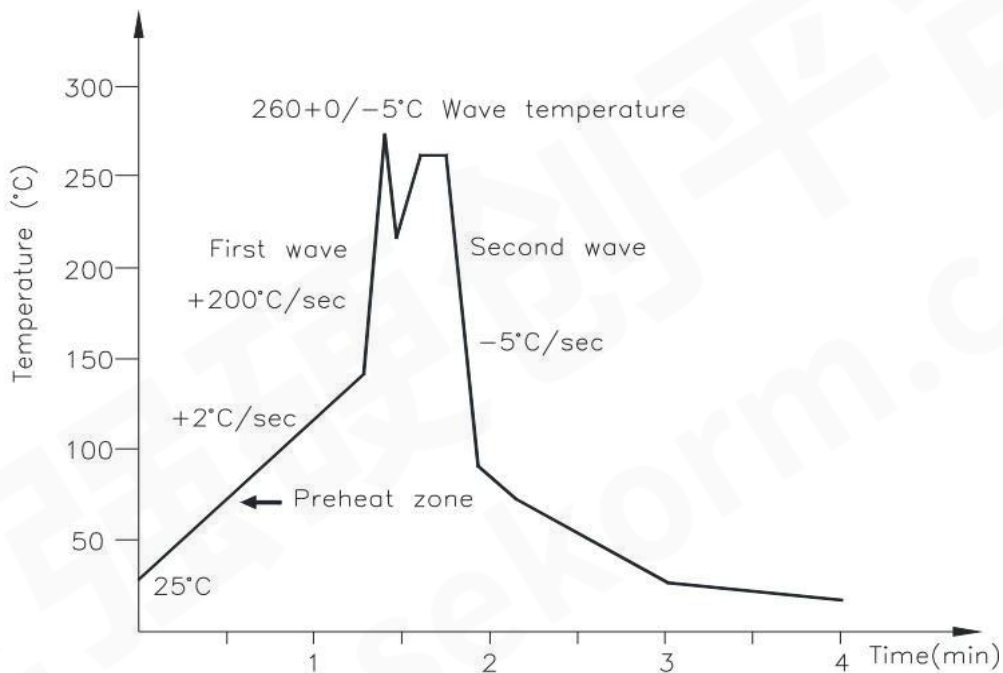

(3) Hand soldering by soldering iron

Single lead welding is allowed in each process and one-time welding is recommended.

Temperature	380+0/-5°C
Time	3 sec max

16. Characteristics Curve

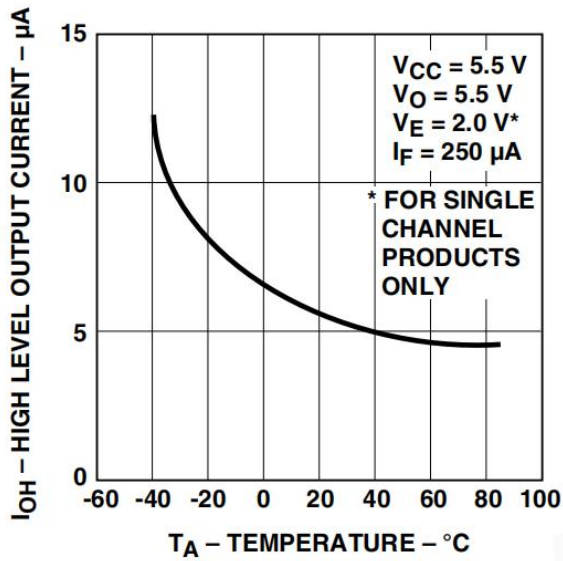

Figure 1. Typical high level output current vs. temperature.

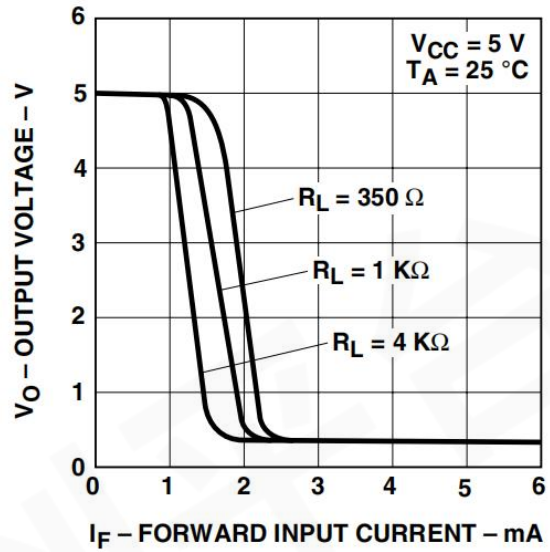

Figure 2. Typical output voltage vs. forward input current.

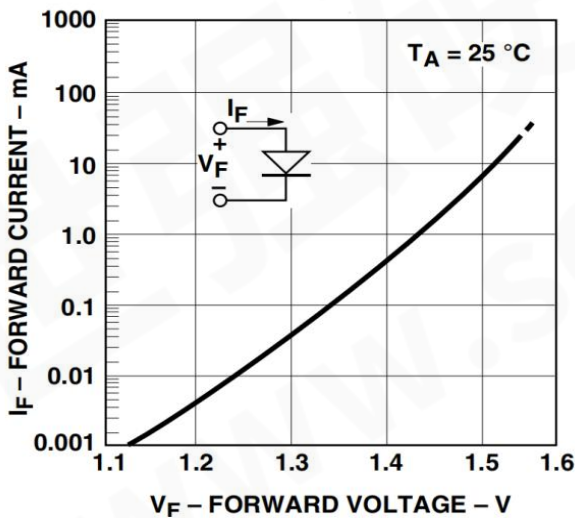

Figure 6. Typical input diode forward characteristic.

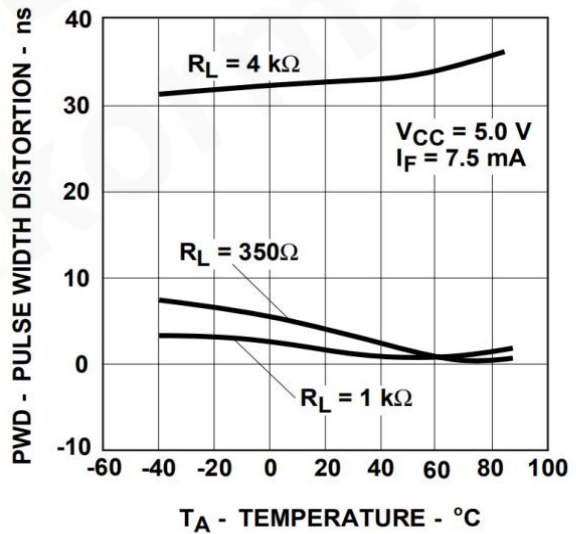

Figure 7. Typical temperature coefficient of forward voltage vs. input current.

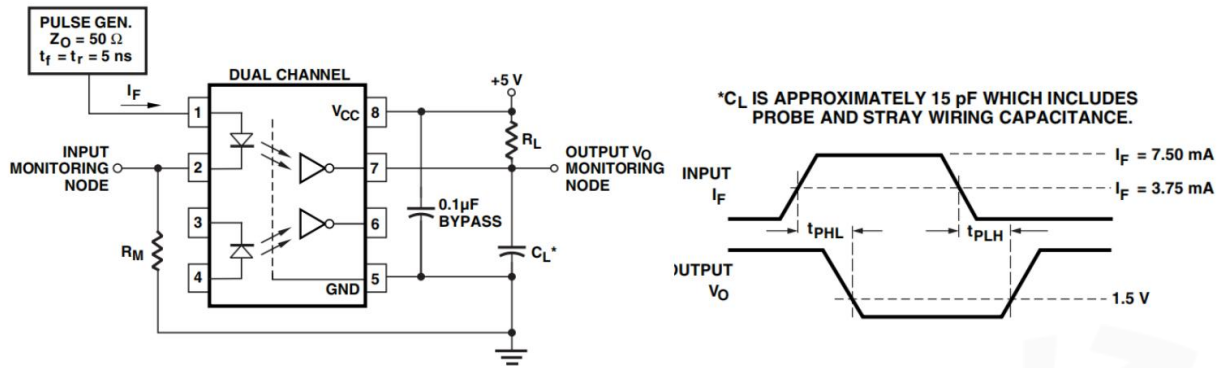

Figure 8. Test circuit for t_{pHL} and t_{pLH} .

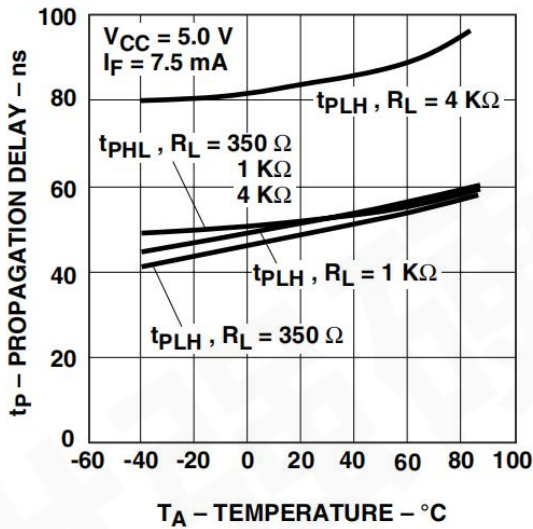

Figure 9. Typical propagation delay vs. temperature.

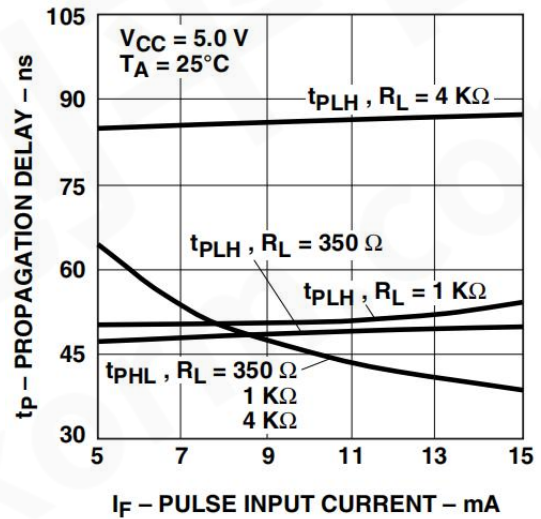

Figure 10. Typical propagation delay vs. pulse input current.

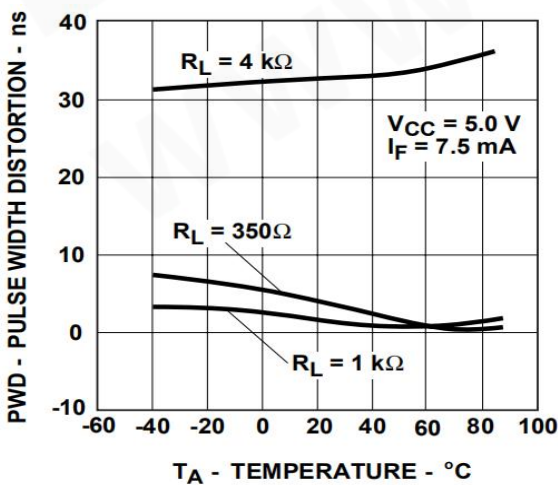

Figure 11. Typical pulse width distortion vs. temperature.

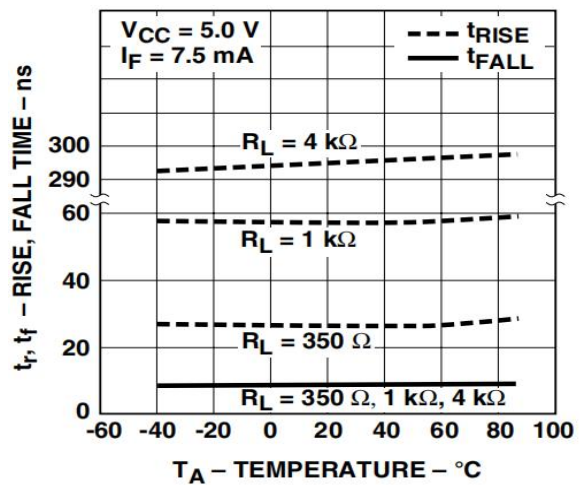

Figure 12. Typical rise and fall time vs. temperature.

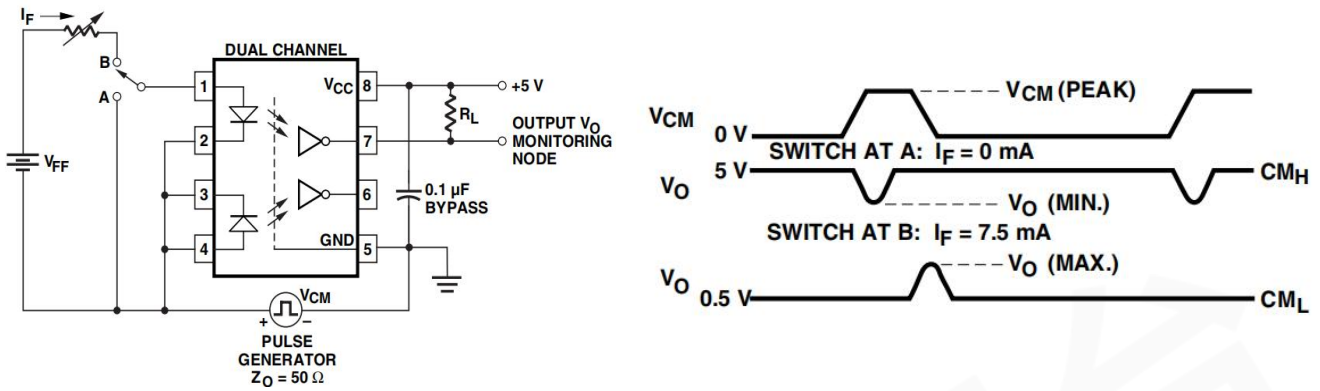

Figure 15. Test circuit for common mode transient immunity and typical waveforms.

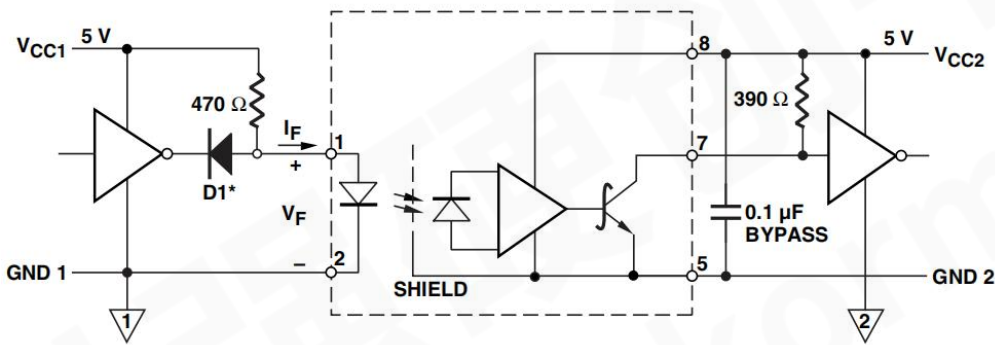

Figure 18. Recommended TTL/LSTTL to TTL/LSTTL interface circuit.

X-ON Electronics

Largest Supplier of Electrical and Electronic Components

Click to view similar products for [Logic Output Opto-couplers](#) category:

Click to view products by [Orient](#) manufacturer:

Other Similar products are found below :

[CPC1590P](#) [FOD3150A](#) [TLP5214A\(E\(O](#) [FOD3125SD](#) [FOD8482T](#) [LTV-332J-TP1](#) [TLP719F\(D4-TP,F\)](#) [LTV-T350S-TA1](#) [PC925LEYIP0F](#)
[SL3120R](#) [H11L1-JSM](#) [6N137](#) [LTV-5314W-TP1](#) [H11L1S-JSM](#) [6N136](#) [SLH11L1](#) [CY6N139](#) [CY6N137](#) [ICPL2611SM](#) [ELS3150P\(TA\)-VG](#)
[OR-0631-TA1](#) [ICPL2611SMT&R](#) [CYHCPL2630](#) [H11L1S\(TA\)](#) [H11L3SR2M](#) [HCPL-0302-000E](#) [HCPL-J312-000E](#) [LTV-3120S-TA1](#)
[TLP155E\(TPL,E\)](#) [TLP2345\(E\(T](#) [TLP2348\(E\(T](#) [TLP350H\(F\)](#) [TLP5214\(E\(O](#) [8302401EC](#) [TLP351H\(F\)](#) [TLP5214\(TP,E\(O](#) [TLP5702\(TP,E](#)
[5962-8947701PA](#) [ACPL-W343-500E](#) [TLP351H\(TP1,F\)](#) [FOD3120SDV](#) [FOD8160](#) [FOD3184TSR2V](#) [HCPL-6750](#) [TLP152\(TPL,E](#) [H11L1](#)
[TLP250\(F\)](#) [VO3150A-X017T](#) [FOD8342TR2V](#) [TLP5214A\(D4-TP,E](#)