



# ORIENT

## Photo coupler

### Product Data Sheet

Part Number: OR-M304X/OR-M306X/OR-M308X

Customer: \_\_\_\_\_

Date: \_\_\_\_\_

**SHENZHEN ORIENT COMPONENTS CO., LTD**

Block A 3rd Floor No.4 Building, Tian'an Cyber Park, Huangge Rd, LongGang Dist, Shenzhen, GD

TEL: 0755-29681816  
FAX: 0755-29681200  
[www.orient-opto.com](http://www.orient-opto.com)

### 1. Features

- (1) High isolation voltage between input and output (Viso:3750 V rms)
- (2) 4pin zero-cross optoisolators triac driver output
- (3) High repetitive peak off-state voltage VDRM :  
304X: Max. 400V,306X: Max. 600V,308X: Max. 800V
- (4) High critical rate of rise of off-state voltage dv/dt : MIN. 1000 V / us
- (5) Tape and reel packaging.
- (6) Operating temperature -40 °C to +110 °C
- (7) MSL Class I



### 2. Description

The OR-M304X, OR-M306X, OR-M308X each consist of a GaAs infrared emitting diode optically coupled to a monolithic silicon zero voltage crossing photo triac. They are designed for use with a discrete power triac in the interface of logic systems, such as solid-state relays, industrial controls, motors, solenoids and consumer appliances.

### 3. Application Range

- AC Motor Drives
- AC Motor Starters
- Static power switch
- Lighting Controls
- Solenoid/Valve Controls
- Solid State Relays
- Temperature Controls

### 4. Absolute Maximum Ratings (Ta=25°C)

Parameter		Symbol	Rated Value	Unit	
Input	Forward Current	$I_F$	50	mA	
	Junction Temperature	$T_J$	125	°C	
	Reverse Voltage	$V_R$	6	V	
	Power Dissipation	$P$	100	mW	
Output	Off-State Output Terminal Voltage	OR-M304X	$V_{DRM}$	400	V
		OR-M306X		600	
		OR-M308X		800	
	On state RMS current		$I_{T(RMS)}$	70	mA(RMS)
	Junction Temperature		$T_J$	125	°C
	Collector Power Dissipation		$P_C$	300	mW
Total Power Dissipation		$P_{tot}$	330	mW	
*1 Insulation Voltage		$V_{iso}$	3750	Vrms	
Working Temperature		$T_{opr}$	-40 ~ + 110	°C	
Deposit Temperature		$T_{stg}$	-55 ~ + 125		
*2 Soldering Temperature		$T_{sol}$	260		

Notes:

\*1 AC for 1 minute, R.H.= 40 ~ 60% R.H. In this test, pins 1, 2&3 are shorted together, and pins 4, 6 are shorted together.

\* 2 For 10 seconds

**5. Electrical Optical Characteristics at Ta=25°C**

Parameter		Symbol	Condition	Min	Typ.*	Max	Unit				
Input	Forward Voltage	$V_F$	$I_F=30\text{mA}$	---	1.2	1.6	V				
	Reverse Current	$I_R$	$V_R=6\text{V}$	---	---	5	$\mu\text{A}$				
Output	*1.Peak Blocking Current, Either Direction	$I_{\text{DRM}}$	$V_{\text{DRM}} = \text{Rated } V_{\text{DRM}}$	---	10	100	nA				
	Inhibit Voltage (MT1-MT2 voltage above which device will not trigger)	$V_{\text{INH}}$	$I_F = \text{Rated } I_{\text{FT}}$	---	---	20	V				
	Peak On-State Voltage, Either Direction	$V_{\text{TM}}$	$I_{\text{TM}}=100\text{mA Peak}$	---	1.7	3.0	V				
	*2.Critical rate of Rise of Off-State Voltage	dv/dt	$V_{\text{in}}=240\text{Vrms}$	1000	---	---	V/us				
Transfer Characteristics	*3.Led Trigger Current, Current Required to Latch Output, Either Direction	OR-M3040 OR-M3060 OR-M3080	$I_{\text{FT}}$	Main Terminal Voltage = 3V	---	---	30	mA			
		OR-M3041 OR-M3061 OR-M3081			---	---	15				
		OR-M3042 OR-M3062 OR-M3082			---	---	10				
		OR-M3043 OR-M3063 OR-M3083			---	---	5				
		OR-M3044 OR-M3064 OR-M3084			---	---	3				
		Holding Current, Either Direction			$I_{\text{H}}$	---	280		---	$\mu\text{A}$	

\*1. Test voltage must be applied within dv/dt rating.

\*2. This is static dv/dt. Commutating dv/dt is a function of the load-driving thyristor(s) only.

\*3. All devices are guaranteed to trigger at an  $I_F$  value less than or equal to max  $I_{\text{FT}}$ . Therefore, recommended operating  $I_F$  lies between max  $I_{\text{FT}}$ , 30 mA for OR-M3040 and OR-M3060 and OR-M3080, 15 mA for OR-M3041 and OR-M3061 and OR-M3081, 10 mA for OR-M3042 and OR-M3062 and OR-M3082, 5 mA for OR-M3043 and OR-M3063 and OR-M3083, 3 mA for OR-M3044, OR-M3064 and OR-M3084, and absolute max  $I_F$  (50mA).



## 6. Order Information

Part Number

**OR-M304X-Z**

or **OR-M306X-Z**

or **OR-M308X-Z**

### Note

X = Part Number(0,1,2,3 or 4)  
Z = Tape and reel option (TP or TP1).

- \* Halogen Free can be selected.
- \* VDE Code can be selected.

Option	Description	Packing quantity
TP	Surface mount lead form (low profile) + TP tape & reel option	3000 units per reel
TP1	Surface mount lead form (low profile) + TP1 tape & reel option	3000 units per reel

## 7. Naming Rule

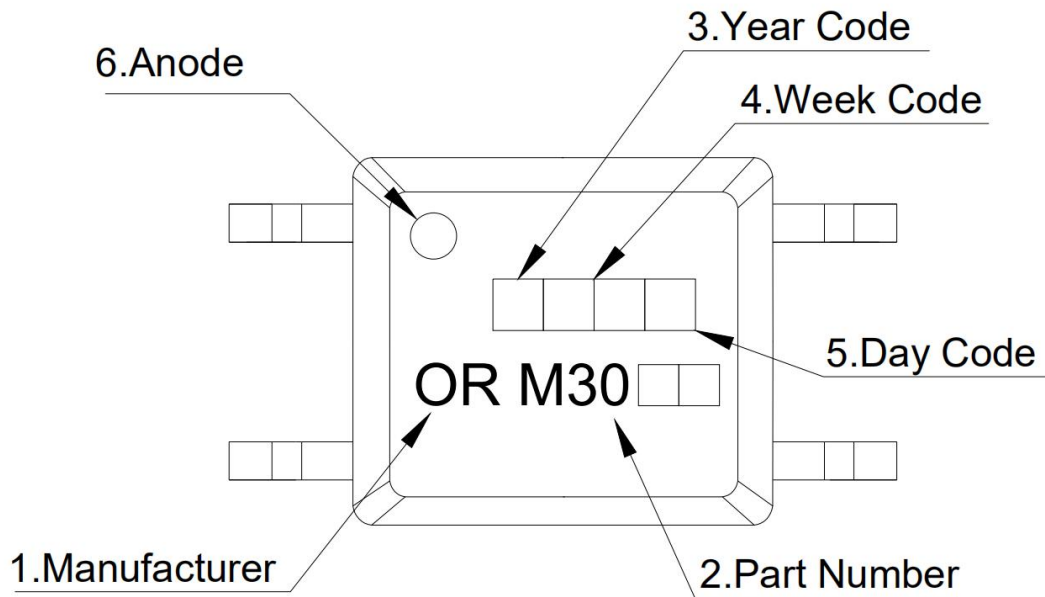

### NOTE:

- (1) ORIENT .
- (2) 30   denotes Part Number.
- (3)  denotes Year Code.
- (4)   denotes Week Code.
- (5)  denotes Day Code.
- (6) Anode.

\* If the photo coupler is Free from Halogen, there will be a ' G ' mark in the upper left corner.

\* VDE Code can be selected.

### 8. Package Dimension

OR-M30XX

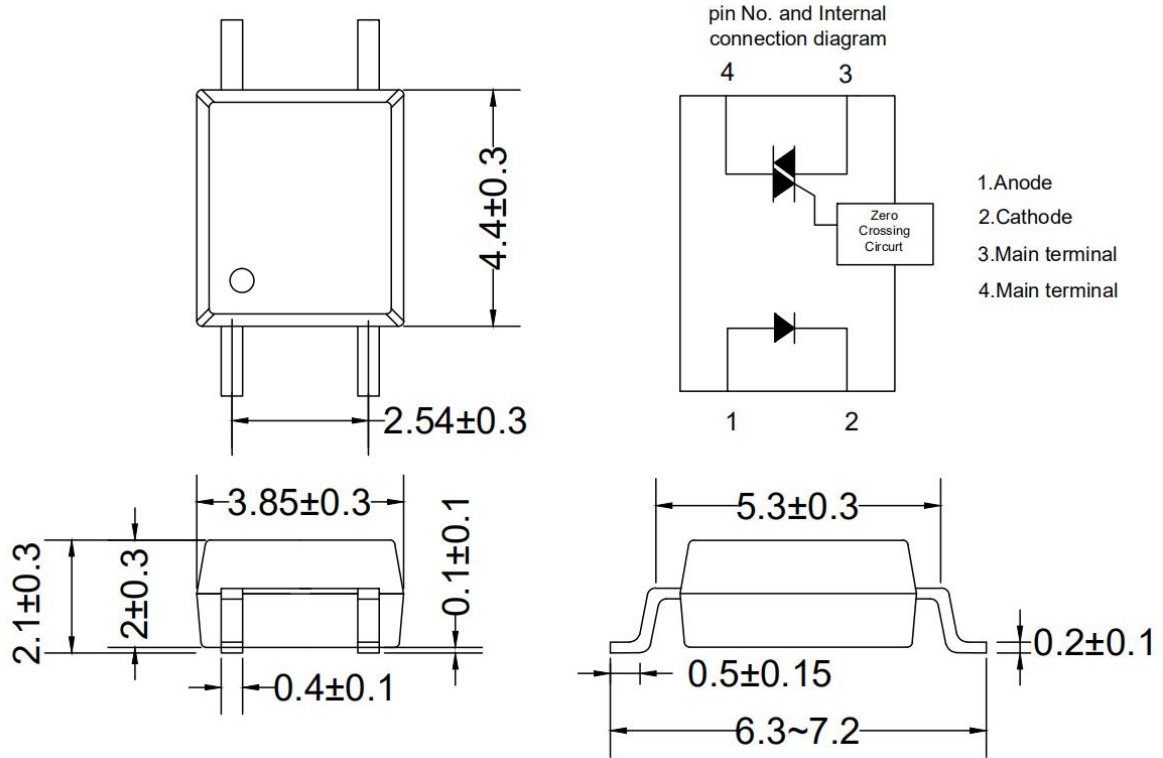

### 9. Recommended Foot Print Patterns (Mount Pad)

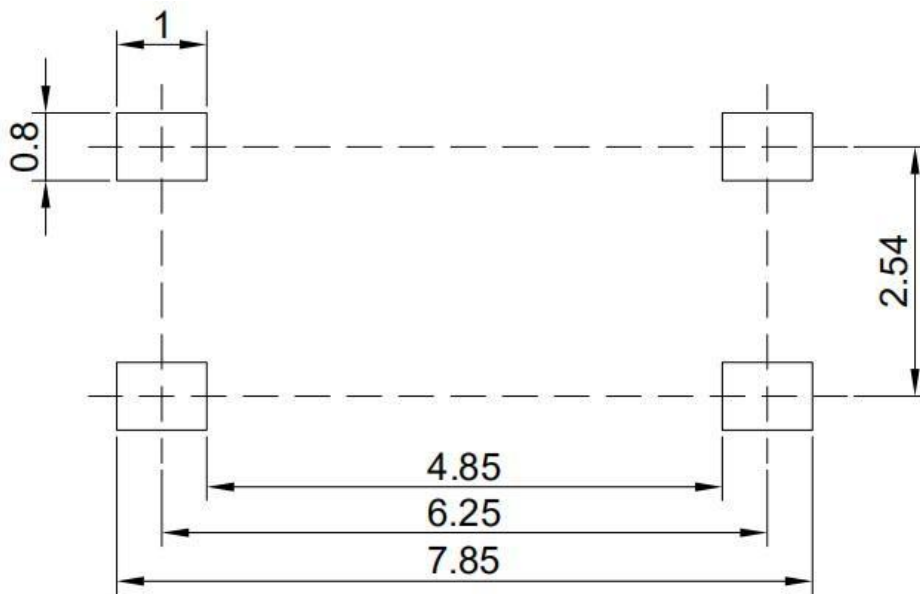

unit: mm

### 10. Taping Dimensions

#### (1)OR-M30XX-TP

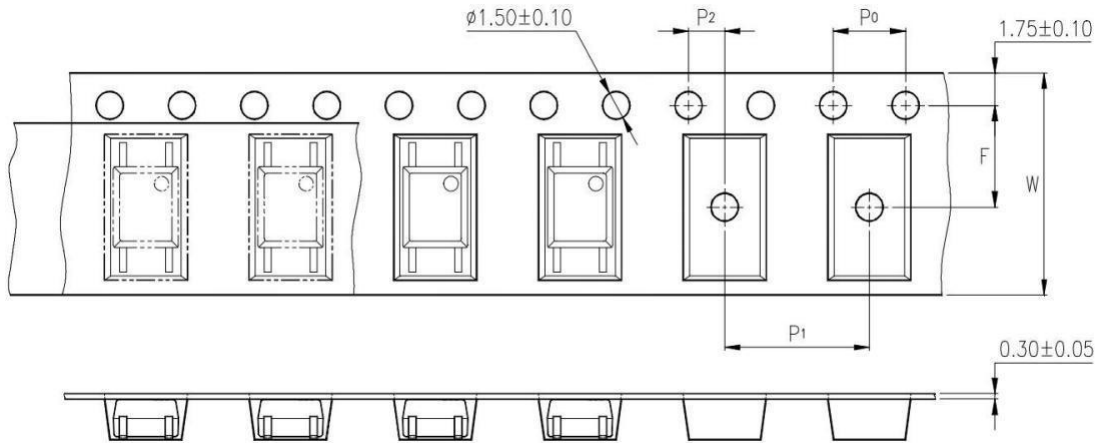

#### (2)OR-M30XX-TP1

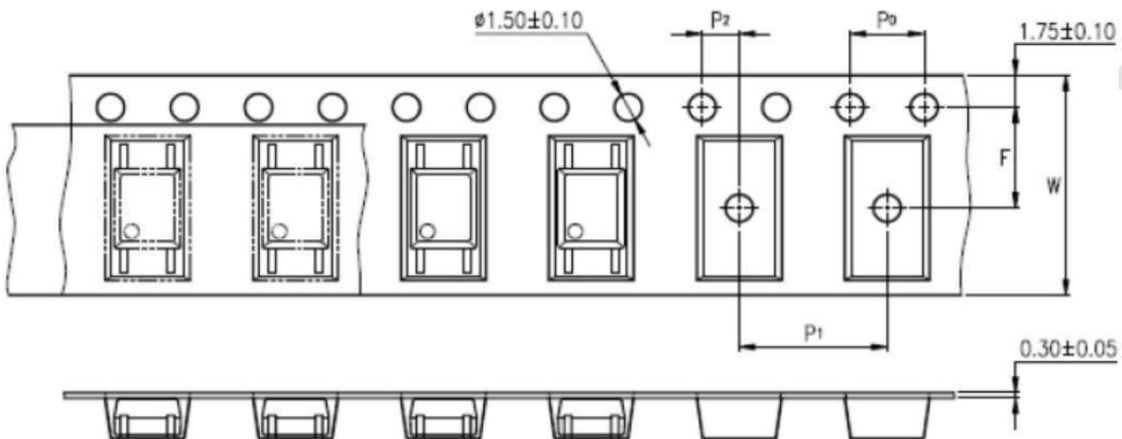

Description	Symbol	Dimension in mm (inch)
Tape wide	W	12±0.3 (0.472)
Pitch of sprocket holes	P0	4±0.1 (0.157)
Distance of compartment	F	5.5±0.1 (0.217)
	P2	2±0.1 (0.079)
Distance of compartment to compartment	P1	8±0.1 (0.315)

Package Type	TP/TP1
Quantities(pcs)	3000

## 11.Package Dimension

### (1) package dimension

#### Packing Information

Packing Information	
Packing type	Reel type
Tape Width	12mm
Qty per Reel	3,000
Small box (inner) Dimension	345*345*45mm
Max qty per small box	6,000
Large box (Outer) Dimension	480x360x360mm
Max qty per large box	60,000

### (2)Packing Label Sample



1. MTL NO:Contents with "Order Information" in the specification.
2. LOT NO:The production cycle of the product.
3. BATCH:The CTR RANK of the product.
4. Quantity:Product packaging quantity.
5. Product Data: The data when product be made.



## 12. Reliability Test

NO.	Item	Condition	Quantity	Cycle	Reference Standards
1	RSH, Resistance to Solder Heat	260±5°C, 20s/cycle	22	3 cycles	JESC22A-106
2	SD, Solderability	260±5°C, 10s/cycle	22	1 cycle	JESD22-B102
3	TC, Temperature Cycle	H: 125°C 15min ∫ 5min L: -55°C 15min	77	300cycles	JESC22A-104
4	TS, Thermal Shock	H: 100°C 5min ∫ 15s L: -10°C 5min	77	300cycles	JESC22A-106
5	LTSL, Low Temperature Storage	T: -55°C	77	1000h	JESD22-A119
6	HTSL, High Temperature Storage	T: 125°C	77	1000h	JESC22A-103
7	THB, High Temperature High Humidity	T: 85°C RH: 85%	77	1000h	JESC22A-101
8	HTOL DC Operating Life	T: 110°C IF=10mA VCC=5V	77	1000h	MIL-STD-750 Method 1037
9	ESD-HBM Human Body Model ESD	Ta=25°C, Reference JESD22-A114	6	1 cycle	JESD22-A114

### 13. Temperature Profile Of Soldering

(1).IR Reflow soldering (JEDEC-STD-020C compliant)

One time soldering reflow is recommended within the condition of temperature and time profile shown below. Do not solder more than three times.

Profile item	Conditions
Preheat - Temperature Min (T Smin ) - Temperature Max (T Smax ) - Time (min to max) (ts)	150°C 200°C 90±30 sec
Soldering zone - Temperature (TL ) - Time (t L )	217°C 60 sec
Peak Temperature	260°C
Peak Temperature time	20 sec
Ramp-up rate	3°C / sec max.
Ramp-down rate from peak temperature	3~6°C / sec
Reflow times	≤3

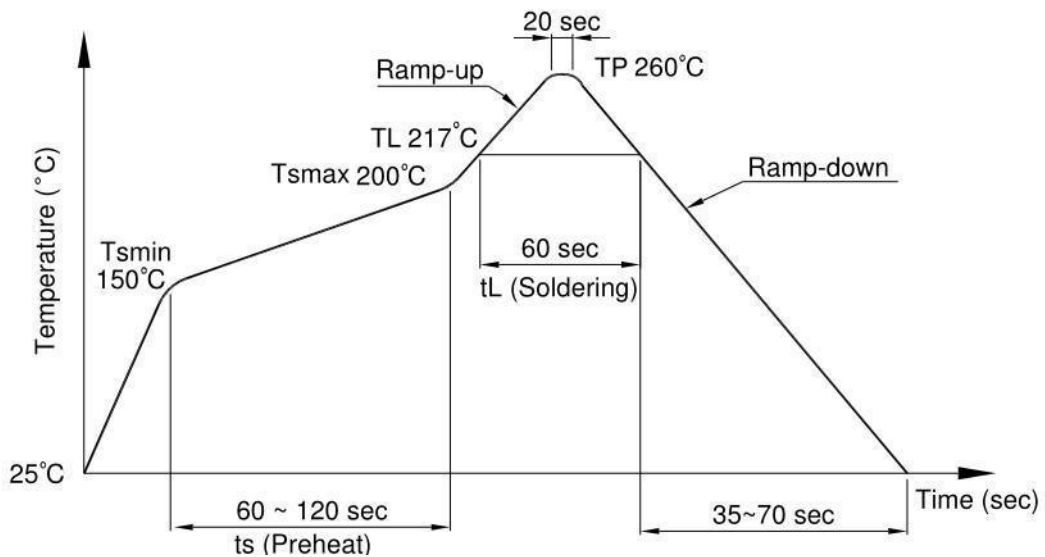

**(3) Wave soldering (JEDEC22A111 compliant)**

One time soldering is recommended within the condition of temperature.

Temperature	260+0/-5°C
Time	10 sec
Preheat temperature	5 to 140°C
Preheat time	30 to 80 sec

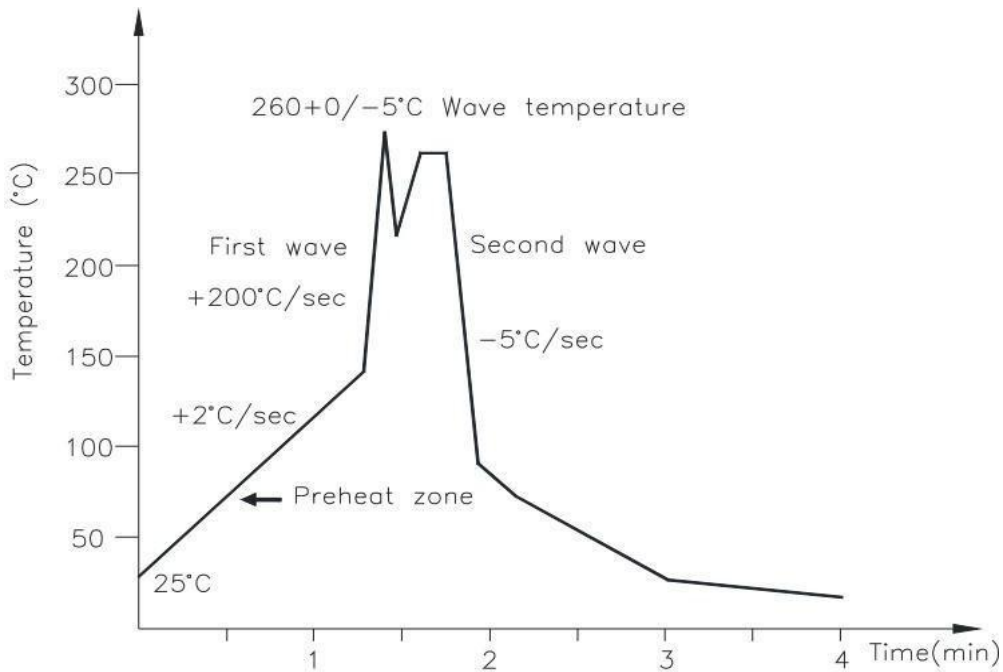

**(4) Hand soldering by soldering iron**

Allow single lead soldering in every single process. One time soldering is recommended.

Temperature	380+0/-5°C
Time	3 sec max

### 14.CHARACTERISTICS CURVES (TYPICAL PERFORMANCE)

Fig.1 Forward current vs Ambient temperature

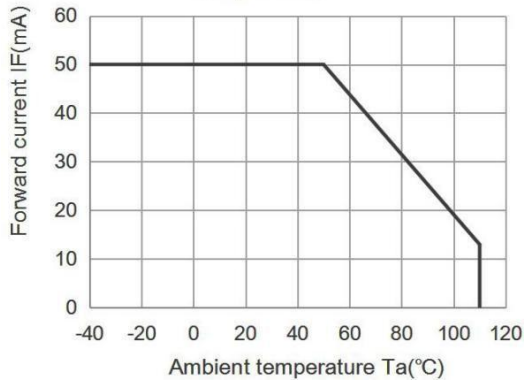

Fig.2 On-state current ITM (A) vs Ambient temperature

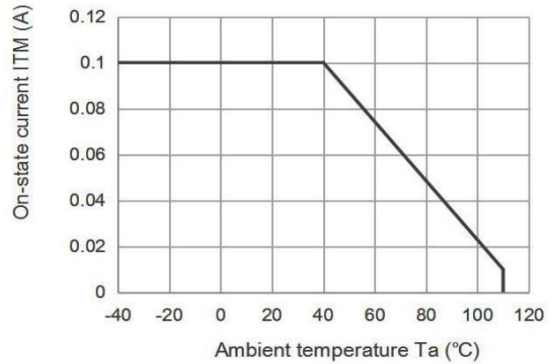

Fig.3 Minimum Trigger Current vs. Ambient temperature

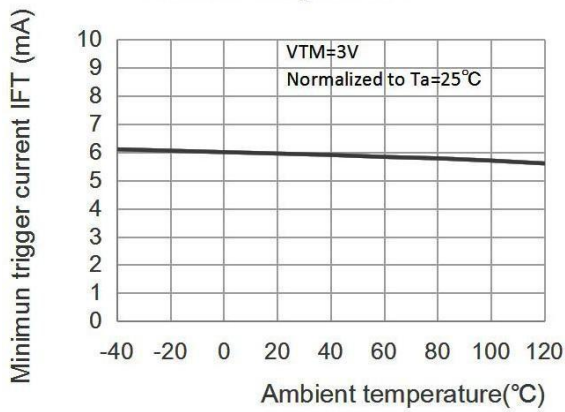

Fig.4 Forward current vs. Forward voltage

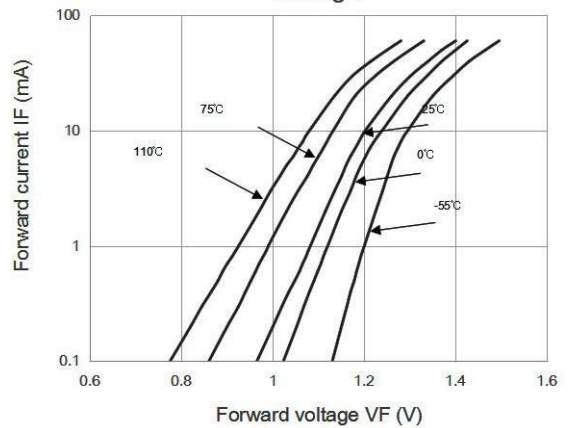

Fig.5 On-state voltage vs. Ambient temperature

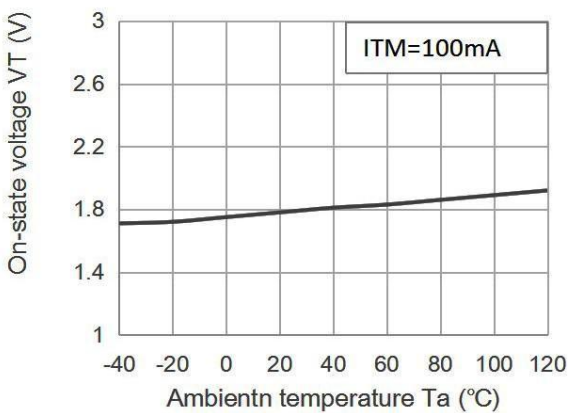

Fig.6 Holding current vs. Ambient temperature

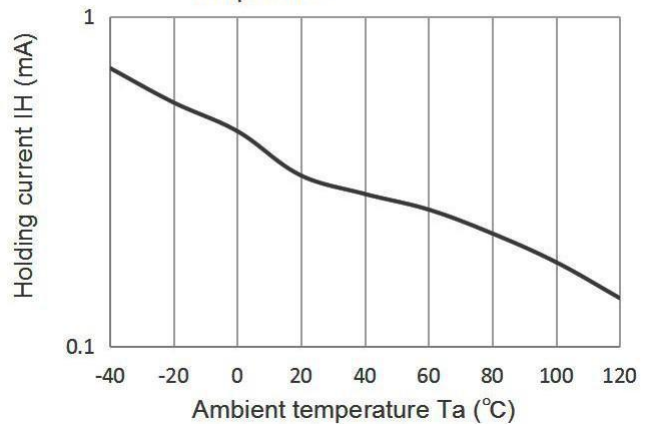

Fig.7 Repetitive peak off-state current vs. Temperature

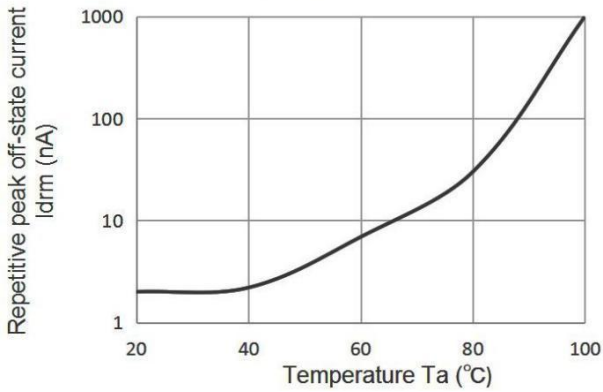

Fig.8 On-state current vs. On-state voltage

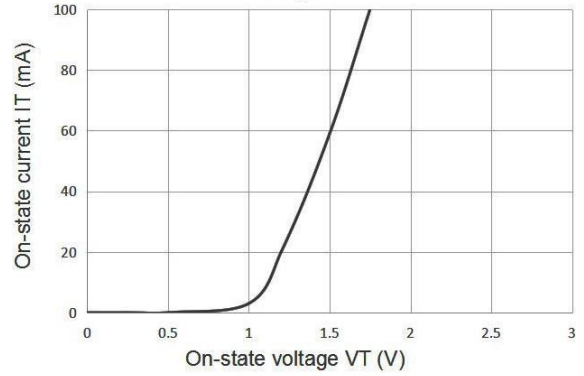

Fig9. Basic Operation Circuit Medium/High Power Triac Drive Circuit

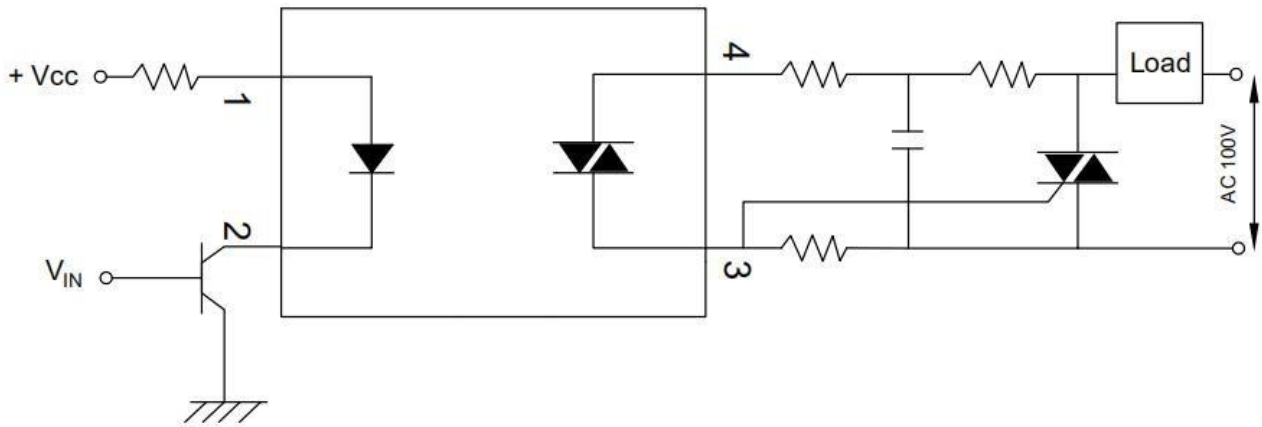
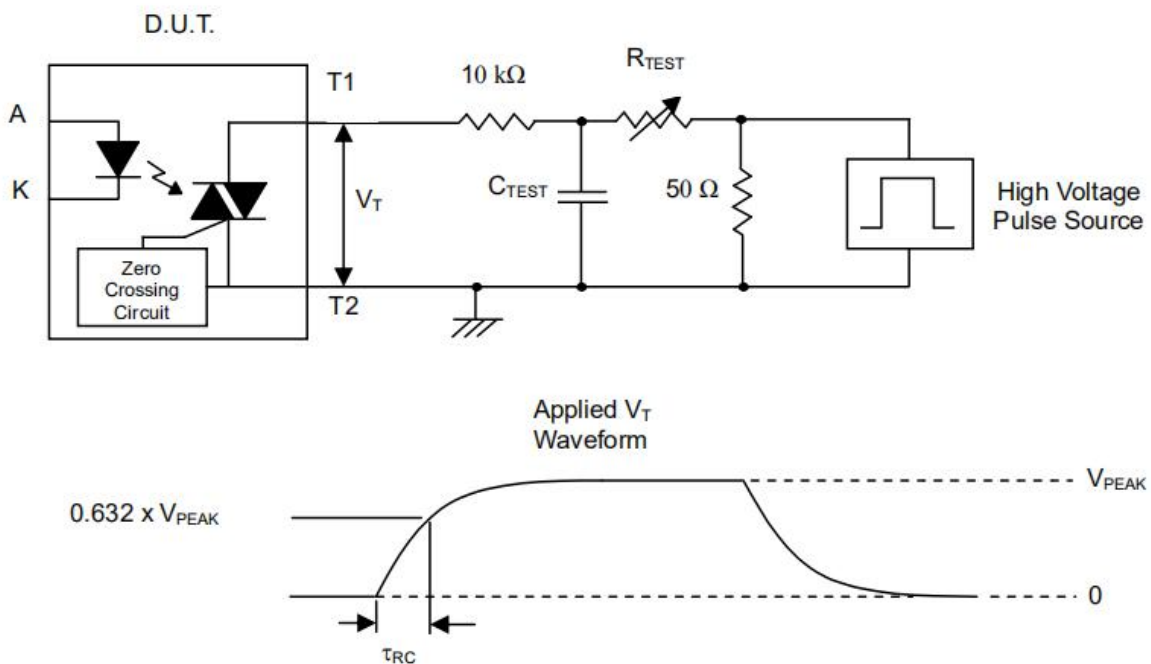

Fig10. Static dv/dt Test Circuit & Waveform



## Measurement Method

The high voltage pulse is set to the required  $V_{PEAK}$  value and applied to the D.U.T. output side through the RC circuit above. LED current is not applied. The waveform  $V_T$  is monitored using a x100 scope probe. By varying  $R_{TEST}$ , the  $dv/dt$  (slope) is increased, until the D.U.T. is observed to trigger (waveform collapses). The  $dv/dt$  is then decreased until the D.U.T. stops triggering. At this point,  $\tau_{RC}$  is recorded and the  $dv/dt$  calculated.

$$dv/dt = \frac{0.632 \times V_{PEAK}}{\tau_{RC}}$$

$$dv/dt = \frac{0.632 \times V_{PEAK}}{\tau_{RC}}$$

For example,  $V_{PEAK} = 600V$  for EL306X series. The  $dv/dt$  value is calculated as follows:

$$dv/dt = \frac{0.63 \times 600}{\tau_{RC}} = \frac{378}{\tau_{RC}}$$

## X-ON Electronics

Largest Supplier of Electrical and Electronic Components

*Click to view similar products for [Triac & SCR Output Optocouplers](#) category:*

*Click to view products by [Orient](#) manufacturer:*

Other Similar products are found below :

[MOC3063S-TA](#) [ILD207-X001T](#) [ILD615-1X007T](#) [VO2223-X001](#) [VO4254H](#) [WPPCT-N1066A](#) [WPPCT-N1566A](#) [WPPCT-Z546D](#) [523170E](#)  
[VO2223A-X007T](#) [WPPCT-Z546A](#) [WPPCT-Z1046D](#) [WPPCT-Z1046A](#) [WPPCT-N566D](#) [WPPCT-N566A](#) [WPPCT-N1566D](#)  
[FODM3053V\\_NF098](#) [TLP3042SCF](#) [VO4258D](#) [VO4256D](#) [VO4158H-X017T](#) [TLP3083\(TP1,F](#) [MOC3071SM](#) [MOC3063STA1-V](#) [IL4116-](#)  
[X007](#) [MOC3072SM](#) [VO0601-X001T](#) [OR-M3052](#) [TLP265J\(E\(T](#) [MOC3020XSM](#) [MOC3021X](#) [MOC3021XSM](#) [MOC3022X](#)  
[MOC3023SR2M](#) [MOC3041SM](#) [MOC3042XSM](#) [MOC3043SR2M](#) [MOC3043X](#) [MOC3043XSM](#) [MOC3052SM](#) [MOC3063X](#) [MOC3081X](#)  
[MOC3081XSM](#) [IS620XSM](#) [IS623X](#) [VO3062-X007T](#) [VO3063-X006](#) [PC3SG21YIZ](#) [MOC3020](#) [MOC3020X](#)