

# AC Fan Speed Control Unit

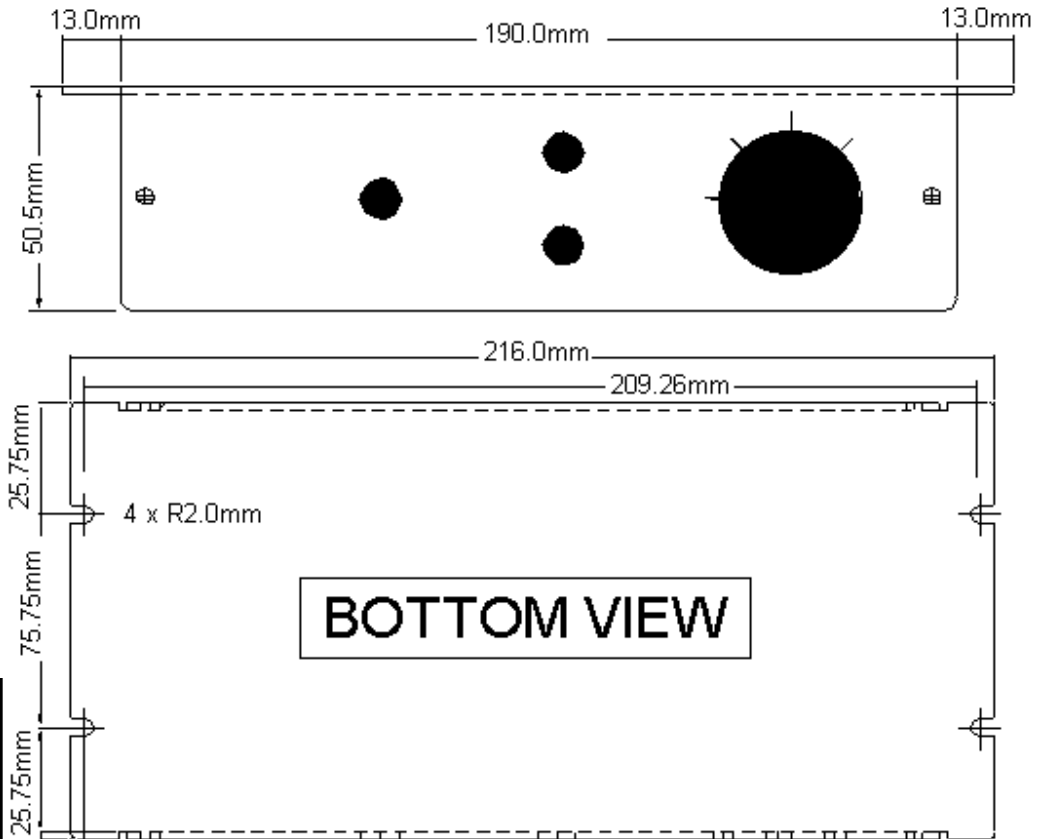

Input Voltage:	120/220 VAC±15%
Input Protection:	2A Circuit Breaker
Output Protection:	2A Circuit Breaker (Each Channel)
4 Preset Settings:	Off, Low, Medium, & High
Speed Adjustment:	External 4 Detent Rotary Switch (Off, Low, Medium, High) Internal Potentiometers for each speed
Input Connector:	IEC C14
Output Connectors:	IEC C13

## COMMENTS

Contact Manufacturer for alternate circuit breaker configurations and higher current options by special orders.

The Dual Channel Phase Control Unit allows the user to control fan speed for single or multiple fan assemblies. Effectively this allows the application engineer to specify and control fan noise, speed and air delivery very precisely according to specific application requirements. Four factory presets (user adjustable) allows for maximum flexibility with minimum setup time. This unit has been specially designed with fan trays and equipment racks in mind where noise vs airflow needs to be controlled according to immediate needs.

Knight Electronics  
10557 Metric Drive  
Dallas, Texas 75243  
(Tel) 214-340-0265  
(Fax) 214-340-5870  
www.knightonline.com

**Description:**  
Dual Channel Phase Controller

**Part No:**  
OA11/22CB



## X-ON Electronics

Largest Supplier of Electrical and Electronic Components

*Click to view similar products for [Fan Accessories](#) category:*

*Click to view products by [Orion](#) manufacturer:*

Other Similar products are found below :

[LZ31](#) [LZ32P-1](#) [63070-2-4013](#) [64442-1-7612](#) [71882-2-4053](#) [73816-2-3634](#) [854589-1](#) [95778-1-5171](#) [99485901](#) [1247-4-6254](#) [RF119](#) [2151-4-7320](#) [27453.32262](#) [95779-1-5171](#) [9614-2-4013](#) [99485906](#) [F92-B](#) [FG92-W2](#) [2170-4-7320](#) [27453.32241](#) [R88ACPU001M1](#) [R88ACPU001M2](#) [31570-2-4013](#) [LZ215](#) [LZ22-2](#) [LZ24-1](#) [LZ24B](#) [LZ30-9](#) [450-20-0021](#) [450-20-0025](#) [525-00-0009](#) [450-20-0017](#) [450-20-0020](#) [04.846.1353.0](#) [04.846.1453.0](#) [055032](#) [08121](#) [08188](#) [08195](#) [08196](#) [09576-2-4013](#) [54476-2-4013](#) [71883-2-4053](#) [52545-2-4037](#) [63071-2-4013](#) [52544-2-4037](#) [64445-1-7612](#) [66786-4-7320](#) [88601-2-2929](#) [08164](#)