

◆ Features:

- ◇ Fast switching speed
开关速度快
- ◇ High input impedance and low level drive
高输入阻抗和低电平驱动
- ◇ Avalanche energy tested
雪崩能量测试
- ◇ Improved dv/dt capability, high ruggedness
提高 dv/dt 能力, 高耐用性

◆ Applications

- ◇ High efficiency switch mode power supplies
高效率开关电源
- ◇ Power factor correction
功率因数校正
- ◇ Electronic lamp ballast
电子整流器

TO-252

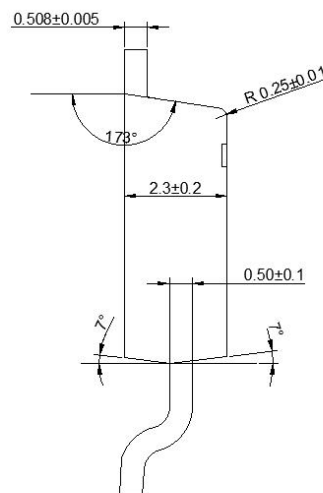
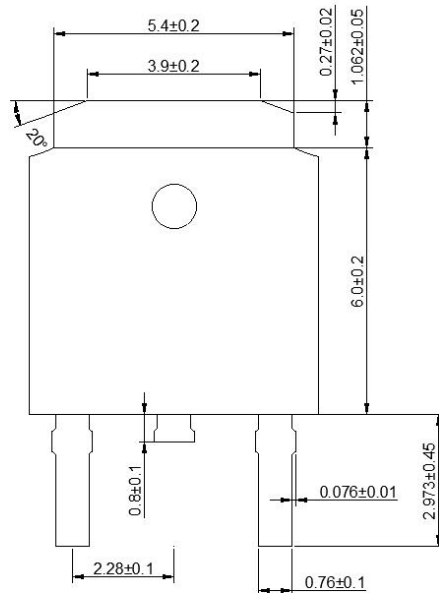
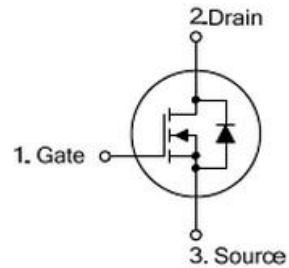
1

单位: mm
TO-252

◆ Absolute Maximum Ratings (Tc=25°C)

Symbol	Parameters	Ratings	Unit
V _{DSS}	Drain-Source Voltage 漏源电压	500	V
V _{GS}	Gate-Source Voltage-Continuous 栅源电压	±30	V
I _D	Drain Current-Continuous 漏极持续电流	12	A
I _{DM}	Drain Current-Single Plused 漏极单次脉冲电流	48	A
P _D	Power Dissipation 功率损耗	55	W
T _j	Max.Operating junction temperature 最大结温	150	°C

◆ Electrical characteristics (Tc=25°C unless otherwise noted)

Symbol	Parameters	Min	Typ	Max	Units	Conditions
Static Characteristics						
B _{VDSS}	Drain-Source Breakdown VoltageCurrent (Note 1) 漏极击穿电压	500	--	--	V	I _D =250μA, V _{GS} =0V, T _J =25°C
V _{GS(th)}	Gate Threshold Voltage 栅极开启电压	2.0	--	4.0	V	V _{DS} =V _{GS} , I _D =250μA
R _{DS(on)}	Drain-Source On-Resistance 漏源导通电阻	--	0.48	--	Ω	V _{GS} =10V, I _D =6A
I _{GSS}	Gate-Body Leakage Current 栅极漏电流	--	--	±100	nA	V _{GS} =±30V, V _{DS} =0
I _{DSS}	Zero Gate Voltage Drain Current 零栅极电压漏极电流	--	--	10	μA	V _{DS} =100V, V _{GS} =0
g _{fs}	Forward Transconductance 正向跨导	2.5	--	--	S	V _{DS} =15V, I _D =20A

Switching Characteristics						
$T_{d(on)}$	Turn-On Delay Time 开启延迟时间	--	28	65	ns	$V_{DS}=250V, I_D=12A,$ $R_G=25\Omega$
T_r	Rise Time 上升时间	--	54	120	ns	
$T_{d(off)}$	Turn-Off Delay Time 关闭延迟时间	--	75	160	ns	
T_f	Fall Time 下降时间	--	47	105	ns	
Q_g	Total Gate Charge 栅极总电荷	--	30	39	nC	$V_{DS}=400V,$ $V_{GS}=10V,$ $I_D=12A$
Q_{gs}	Gate-Source Charge 栅源极电荷	--	8	--	nC	
Q_{gd}	Gate-Drain Charge 栅漏极电荷	--	12	--	nC	
Dynamic Characteristics						
C_{iss}	Input Capacitance 输入电容	--	1450	1943	pF	$V_{DS}=25V, V_{GS}=0,$ $f=1MHz$
C_{oss}	Output Capacitance 输出电容	--	198	265	pF	
C_{rss}	Reverse Transfer Capacitance 反向传输电容	--	14.5	22	pF	
I_S	Continuous Drain-Source Diode Forward Current (Note 2) 二极管导通正向持续电流	--	--	12	A	
V_{SD}	Diode Forward On-Voltage 二极管正向导通电压	--	--	1.5	V	$I_S=12A, V_{GS}=0$
$R_{th(j-c)}$	Thermal Resistance, Junction to Case 结到外壳的热阻	--	2.27	--	$^{\circ}C/W$	

Note 1: Repetitive Rating : Pulse width limited by maximum junction temperature

Note 2: Pulse test: PW \leq 300us , duty cycle \leq 2%.



OSD12N50

500V N-CHANNEL MOSFET

X-ON Electronics

Largest Supplier of Electrical and Electronic Components

Click to view similar products for [MOSFET](#) category:

Click to view products by [OSEN](#) manufacturer:

Other Similar products are found below :

[IRFD120](#) [IRFY240C](#) [JANTX2N5237](#) [2SK2267\(Q\)](#) [BUK455-60A/B](#) [MIC4420CM-TR](#) [VN1206L](#) [NDP4060](#) [SI4482DY](#)
[IPS70R2K0CEAKMA1](#) [SQD23N06-31L-GE3](#) [TK16J60W,S1VQ\(O](#) [2SK2614\(TE16L1,Q\)](#) [DMN1017UCP3-7](#) [EFC2J004NUZTDG](#)
[DMN1053UCP4-7](#) [SQJ469EP-T1-GE3](#) [NTE2384](#) [DMC2700UDMQ-7](#) [DMN2080UCB4-7](#) [DMN61D9UWQ-13](#) [US6M2GTR](#)
[DMN31D5UDJ-7](#) [DMP22D4UFO-7B](#) [DMN1006UCA6-7](#) [DMN16M9UCA6-7](#) [STF5N65M6](#) [IRF40H233XTMA1](#) [STU5N65M6](#)
[DMN6022SSD-13](#) [DMN13M9UCA6-7](#) [DMTH10H4M6SPS-13](#) [DMN2990UFB-7B](#) [IPB80P04P405ATMA2](#) [2N7002W-G](#) [MCAC30N06Y-](#)
[TP](#) [MCQ7328-TP](#) [NTMC083NP10M5L](#) [NVMFS2D3P04M8LT1G](#) [BXP7N65D](#) [BXP4N65F](#) [AOL1454G](#) [WMJ80N60C4](#) [BXP2N20L](#)
[BXP2N65D](#) [BXT1150N10J](#) [BXT1700P06M](#) [TSM60NB380CP](#) [ROG](#) [RQ7L055BGTCR](#) [DMNH15H110SK3-13](#)