

High Voltage Fast-Switching NPN Power Transistor

◆ Features:

- ◇ High Switching Speed
开关速度快
- ◇ Low forward voltage drop
正向压降低
- ◇ High efficiency and low power loss
高效低功耗
- ◇ High current surge capability
大电流浪涌能力强



◆ Applications

- ◇ Electronic Ballast
电子镇流器
- ◇ Switching Mode Power Supply
开关电源
- ◇ Motor Controls
电机控制
- ◇ Solenoid/Relay drivers and Deflection circuits applications
电磁阀/继电器驱动器和偏转电路应用

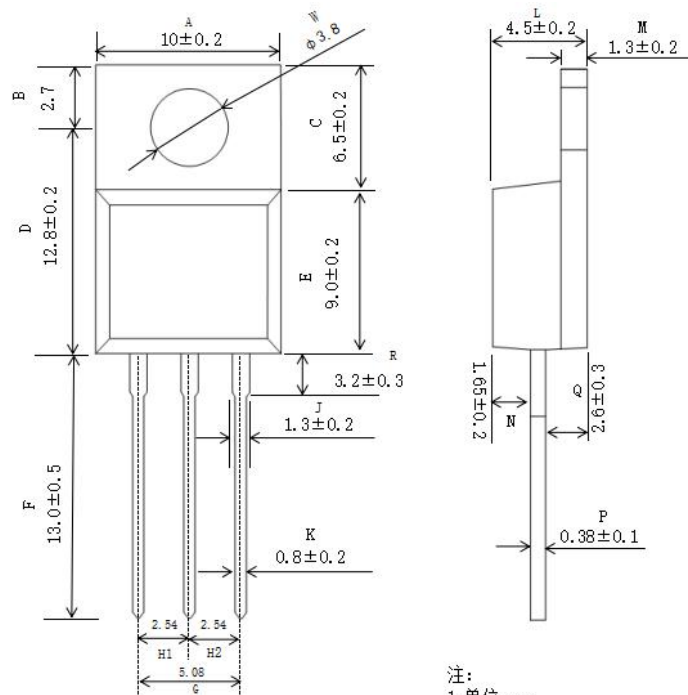
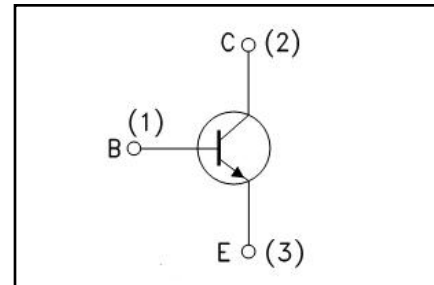

注：
1. 单位：mm
2. 未注公差：±0.2mm
(除非另有说明)

◆ Absolute Maximum Ratings (Tc=25°C)

Symbol	Parameters	Ratings	Unit
VCBO	Collector-Base Voltage 集电极 - 基极电压	700	V
VCEO	Collector-Emitter Voltage 集电极 - 发射极电压	400	V
VEBO	Emitter-Base Voltage 发射极 - 基极电压	9	V
I _c	Collector Current-Continuous 集电极连续电流	12	A
I _B	Base Current-Continuous 基极连续电流	6	A
PC	Collector Power Dissipation 耗散功率	100	W
T _j	Max.Operating junction temperature 最大结温	150	°C
T _{stg}	Storage Temperature 存储温度	-55 ~ +150	°C
θ _{JC}	Junction to Case 结到外壳	1.25	°C/W

◆ Electrical characteristics (Tc=25°C unless otherwise noted)

Symbol	Parameters	Min	Typ	Max	Units	Conditions
I _{CBO}	Collector Cutoff Current 集电极截止电流		--	10	μA	V _{CB} =700V, I _B =0
I _{EBO}	Emitter Cutoff Current 发射极截止电流		--	1	mA	V _{EB} =9V, I _C =0
BV _{CEO}	Collector Emitter Sustaining voltage(Note 1) 集电极发射极持续电压	400			V	I _C =10mA, I _B =0
V _{CE(sat)}	Collector Emitter Saturation Voltage(Note 1) 集电极发射极饱和电压	--	0.3	1.0	V	I _C =5A, I _B =0.1A
V _{BE(sat)}	Base-Emitter Saturation Voltage(Note 1) 基极发射极饱和电压	--	1.0	1.5	V	I _C =3A, I _B =0.6A
h _{FE}	DC Current Gain(Note 1) 直流电流增益	15	--	30		I _C =2A, V _{CE} =5V
f _T	Current-Gain—Bandwidth 电流增益带宽	4	--	--	MHz	V _{CE} =10V, I _C =0.5A, f=1MHz
T _s	Period of storage 贮存时间	2.0	--	8.0	us	I _C =500mA, UI9600
T _r	Up time 上升时间	--	--	1	us	
T _f	Drop-out time 下降时间	--	--	1	us	

Note 1: Pulse test: PW ≤ 300us , duty cycle ≤ 2%.

X-ON Electronics

Largest Supplier of Electrical and Electronic Components

Click to view similar products for [Bipolar Transistors - BJT category](#):

Click to view products by [OSEN manufacturer](#):

Other Similar products are found below :

[BC559C](#) [MCH4017-TL-H](#) [MMBT-2369-TR](#) [BC546/116](#) [NJVMJD148T4G](#) [NTE16](#) [NTE195A](#) [IMX9T110](#) [2N4401-A](#) [2N6728](#) [2SA1419T-TD-H](#) [2SB1204S-TL-E](#) [2SC5488A-TL-H](#) [FMC5AT148](#) [2N2369ADCSM](#) [2N2907A](#) [2N3904-NS](#) [2N5769](#) [2SC4618TLN](#) [CPH6501-TL-E](#) [BC856BW-13-F](#) [US6T6TR](#) [BAX18/A52R](#) [BC556/112](#) [IMZ2AT108](#) [MMST8098T146](#) [MCH6102-TL-E](#) [BC846B-13-F](#) [2N3879](#) [30A02MH-TL-E](#) [NTE13](#) [NTE282](#) [NTE323](#) [NTE350](#) [NTE81](#) [JANTX2N2920L](#) [JANSR2N2907AUB](#) [CMLT3946EG TR](#) [SNSS40600CF8T1G](#) [CMLT3906EG TR](#) [GRP-DATA-JANS2N2907AUB](#) [GRP-DATA-JANS2N2222AUA](#) [MMDT3946FL3-7](#) [2N4240](#) [JANS2N3019](#) [MSB30KH-13](#) [2N2221AUB](#) [2SD1815T-TL-E](#) [2N6678](#) [2N2907Ae4](#)