

◆ **Features:**

- ◇ High efficiency, low deviation
高效率, 低偏差
- ◇ Small input impedance, low consumption of power
输入阻抗小, 功耗低
- ◇ Resistant of high temperature, high humidity
抗高温、高湿
- ◇ Good stability, reliability
稳定性好, 可靠性高

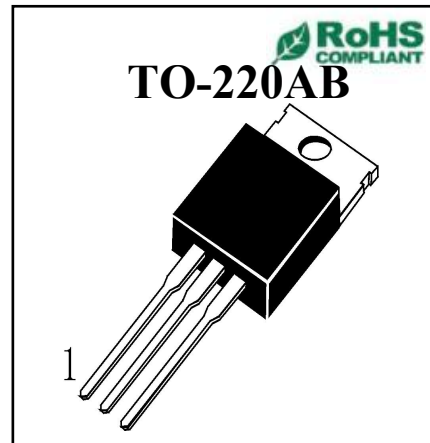

◆ **Applications**

- ◇ Audio amplifier
音频放大器
- ◇ Switching applications
开关应用
- ◇ Complement to Type TIP42C(PNP)
与 TIP42C 互补应用
- ◇ Recommend for 100W high fidelity audio frequency amplifier output stage applications
推荐用于 65W 高保真音频放大器输出级应用

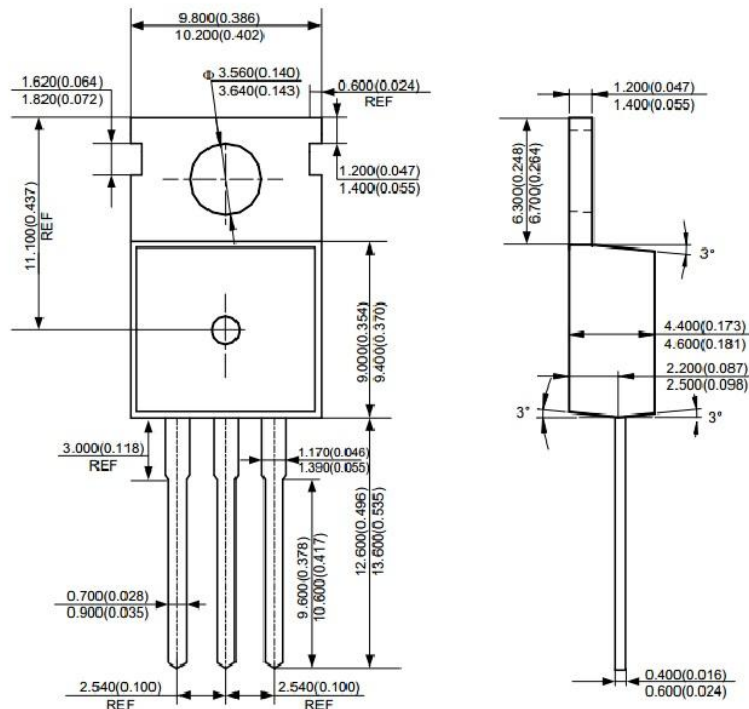
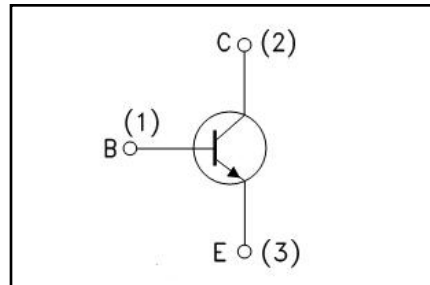

◆ Absolute Maximum Ratings ($T_c=25^{\circ}\text{C}$)

Symbol	Parameters	Ratings	Unit
VCBO	Collector-Base Voltage 集电极 - 基极电压	100	V
VCEO	Collector-Emitter Voltage 集电极 - 发射极电压	100	V
VEBO	Emitter-Base Voltage 发射极 - 基极电压	7	V
I_C	Collector Current-Continuous 集电极连续电流	6	A
I_B	Base Current-Continuous 基极连续电流	1	A
PC	Collector Power Dissipation 耗散功率	65	W
T_j	Max.Operating junction temperature 最大结温	150	$^{\circ}\text{C}$
T_{stg}	Storage Temperature 存储温度	-65 ~ +150	$^{\circ}\text{C}$

◆ Electrical characteristics (Tc=25°C unless otherwise noted)

Symbol	Parameters	Min	Typ	Max	Units	Conditions
I _{CBO}	Collector Cutoff Current 集电极截止电流	--	--	1	uA	V _{CE} =100V, V _{EB} =0
I _{EBO}	Emitter Cutoff Current 发射极截止电流	--	--	1.0	uA	V _{BE} =10V, I _C =0
BV _{CEO}	Collector Emitter Sustaining voltage(Note 1) 集电极发射极持续电压	100	--	--	V	I _C =30mA, I _B =0
V _{CE(sat)}	Collector Emitter Saturation Voltage(Note 1) 集电极发射极饱和电压	--	--	1.5	V	I _C =4A, I _B =0.4A
h _{FE}	DC Current Gain(Note 1) 直流电流增益	80	--	160		I _C =1A, V _{CE} =5V
f _T	Current-Gain—Bandwidth 电流增益带宽	10.0	--	--	MHz	V _{CE} =10V, I _C =0.5A, f=1MHz

Note 1: Pulse test: PW ≤ 300us , duty cycle ≤ 2%.

X-ON Electronics

Largest Supplier of Electrical and Electronic Components

Click to view similar products for [Bipolar Transistors - BJT category](#):

Click to view products by [OSEN manufacturer](#):

Other Similar products are found below :

[BC559C](#) [MCH4017-TL-H](#) [MMBT-2369-TR](#) [BC546/116](#) [NJVMJD148T4G](#) [NTE16](#) [NTE195A](#) [IMX9T110](#) [2N4401-A](#) [2N6728](#) [2SA1419T-TD-H](#) [2SB1204S-TL-E](#) [2SC5488A-TL-H](#) [FMC5AT148](#) [2N2369ADCSM](#) [2N2907A](#) [2N3904-NS](#) [2N5769](#) [2SC4618TLN](#) [CPH6501-TL-E](#) [BC856BW-13-F](#) [US6T6TR](#) [BAX18/A52R](#) [BC556/112](#) [IMZ2AT108](#) [MMST8098T146](#) [MCH6102-TL-E](#) [2N3879](#) [30A02MH-TL-E](#) [NTE13](#) [NTE282](#) [NTE323](#) [NTE350](#) [NTE81](#) [JANTX2N2920L](#) [JANSR2N2907AUB](#) [CMLT3946EG TR](#) [SNSS40600CF8T1G](#) [CMLT3906EG TR](#) [GRP-DATA-JANS2N2907AUB](#) [GRP-DATA-JANS2N2222AUA](#) [MMDT3946FL3-7](#) [2N4240](#) [JANS2N3019](#) [MSB30KH-13](#) [2N2221AUB](#) [2SD1815T-TL-E](#) [2N6678](#) [2N2907Ae4](#) [JAN2N3507](#)