

SOT-23

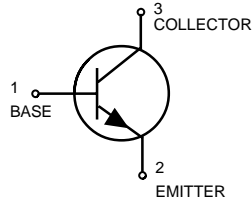
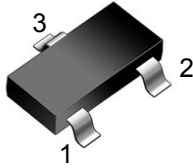

MARKING: 1AM

Features

As complementary type the PNP transistor PMBT3906 is recommended
 Epitaxial planar die construction
 Halogen free and RoHS compliant

Mechanical Data

SOT-23 Small Outline Plastic Package
 Epoxy UL: 94V-0

Summary of Packing Options

| Package | Packing Description | Packing Quantity | Industry Standard |
|---------|---------------------|------------------|-------------------|
| SOT-23 | Tape/Reel, 7" reel | 3000 | EIA-481-1 |

Maximum Ratings & Thermal Characteristics

(Ratings at 25°C ambient temperature unless otherwise specified.)

| Symbol | Parameter | Value | Units |
|------------------|--|-------------|-------|
| V _{CBO} | Collector-Base Voltage | 60 | V |
| V _{CEO} | Collector-Emitter Voltage | 40 | V |
| V _{EBO} | Emitter-Base Voltage | 6 | V |
| I _C | Collector Current -Continuous | 200 | mA |
| P _C | Total Device Dissipation | 200 | mW |
| R _{θJA} | Thermal Resistance Junction to Ambient | 625 | °C/W |
| T _J | Junction Temperature | 150 | °C |
| T _{stg} | Storage Temperature | -55 to +150 | °C |

Electrical Characteristics

(Ratings at 25°C ambient temperature unless otherwise specified.)

| Parameter | Symbol | Test conditions | MIN | MAX | UNIT |
|--------------------------------------|----------------------|--|-----|------|------|
| Collector-base breakdown voltage | V _{CBO} | I _C = 10μA, I _E =0 | 60 | | V |
| Collector-emitter breakdown voltage | V _{CEO} | I _C = 1mA, I _B =0 | 40 | | V |
| Emitter-base breakdown voltage | V _{EBO} | I _E =10μA, I _C =0 | 6 | | V |
| Collector cut-off current | I _{CBO} | V _{CB} =60V, I _E =0 | | 0.1 | μA |
| Collector cut-off current | I _{CEX} | V _{CE} =30V, V _{BE(off)} =3V | | 50 | nA |
| Emitter cut-off current | I _{EBO} | V _{EB} =5V, I _C =0 | | 0.1 | μA |
| DC current gain | h _{FE(1)} | V _{CE} =1V, I _C =10mA | 100 | 400 | |
| | h _{FE(2)} | V _{CE} =1V, I _C = 50mA | 60 | | |
| | h _{FE(3)} | V _{CE} =1V, I _C = 100mA | 30 | | |
| Collector-emitter saturation voltage | V _{CE(sat)} | I _C =50mA, I _B = 5mA | | 0.3 | V |
| Base-emitter saturation voltage | V _{BE(sat)} | I _C = 50mA, I _B = 5mA | | 0.95 | V |
| Transition frequency | f _T | V _{CE} =20V, I _C =10mA, f=100MHz | 300 | | MHz |
| Delay Time | td | V _{CC} =3V, V _{BE} =-0.5V | | 35 | nS |
| Rise Time | tr | I _C =10mA, I _{B1} =-I _{B2} =1.0mA | | 35 | nS |
| Storage Time | ts | V _{CC} =3V, I _C =10mA, | | 200 | nS |
| Fall Time | tf | I _{B1} =-I _{B2} =1mA | | 50 | nS |

CLASSIFICATION OF $h_{FE(1)}$

| | | |
|-------|---------|---------|
| HFE | 100-300 | |
| RANK | L | H |
| RANGE | 100-200 | 200-300 |

Ratings and Characteristic Curves

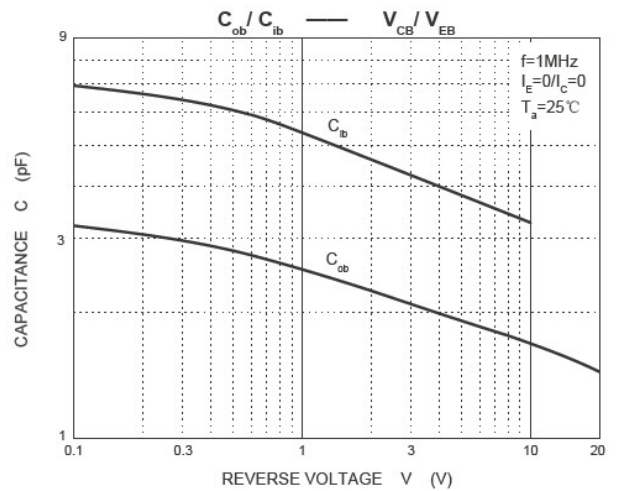
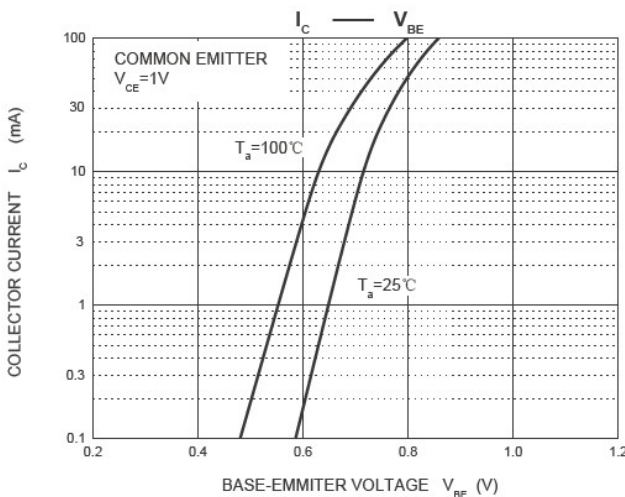
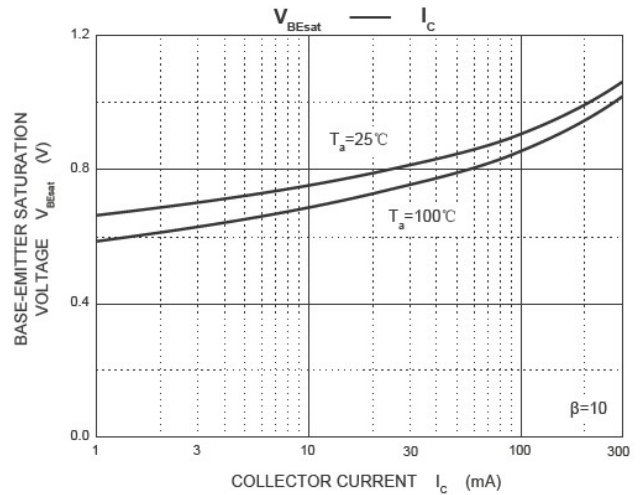
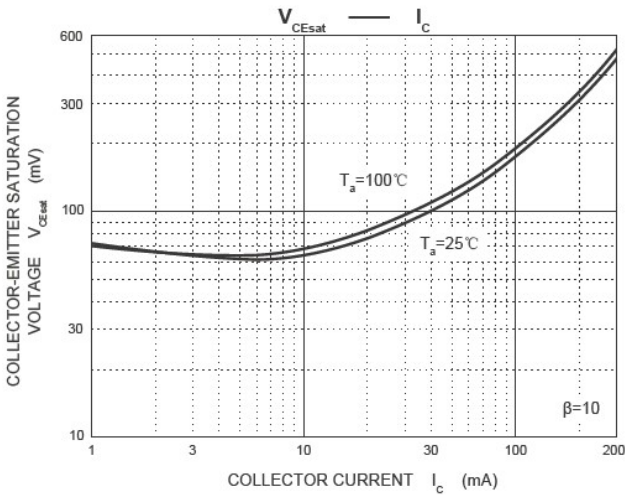
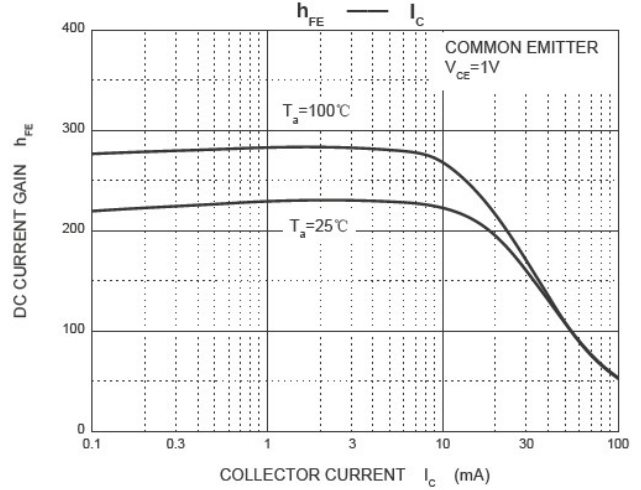
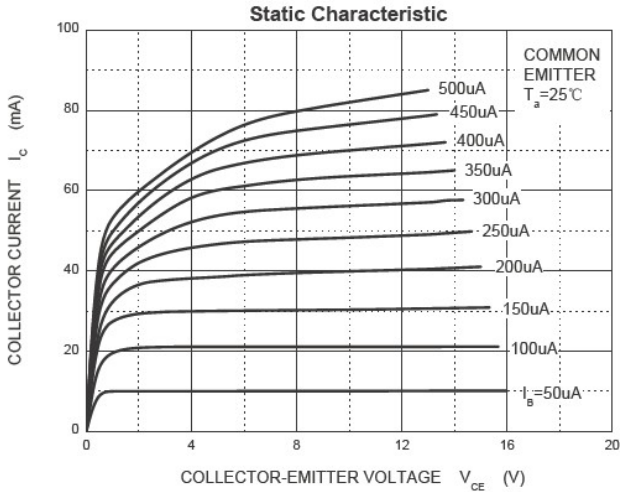

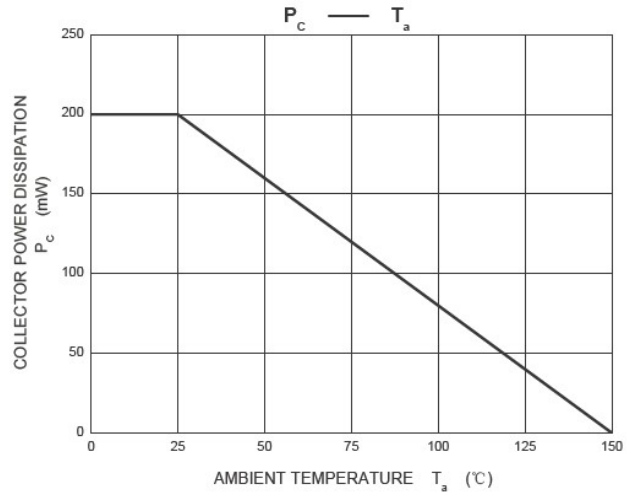
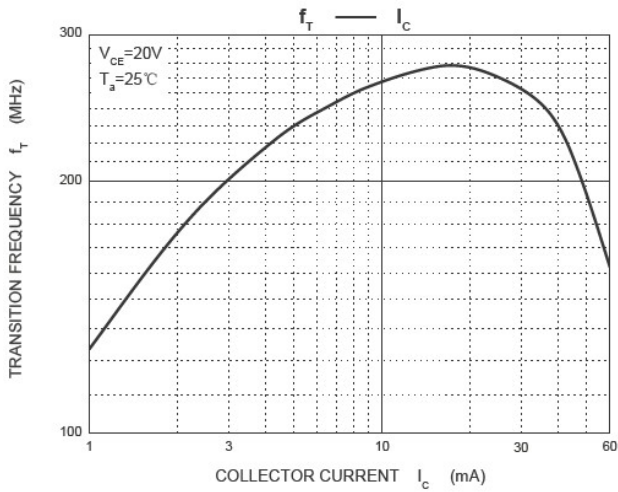

Package Outline Dimensions: SOT-23

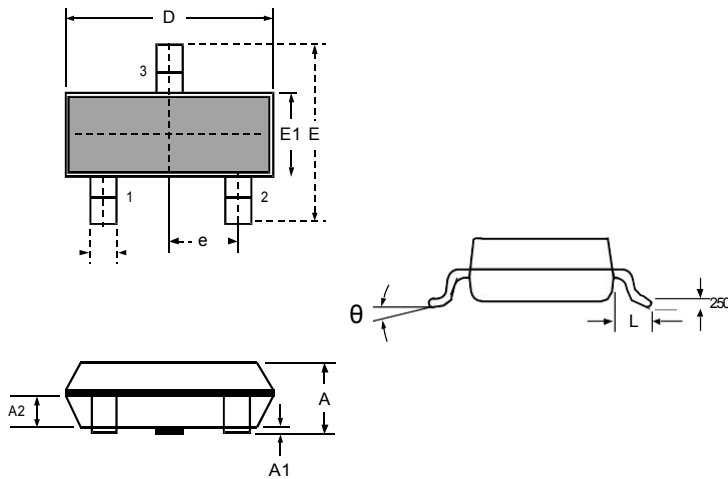

DIMENSIONS

| SYMBOL | MILLIMETER | | INCHES | |
|--------|------------|-------|-----------|-------|
| | MIN | MAX | MIN | MAX |
| A | 0.900 | 1.150 | 0.035 | 0.045 |
| A1 | 0.000 | 0.100 | 0.000 | 0.004 |
| A2 | 0.900 | 1.050 | 0.035 | 0.041 |
| D | 2.800 | 3.000 | 0.110 | 0.118 |
| b | 0.300 | 0.500 | 0.012 | 0.020 |
| E | 2.250 | 2.550 | 0.089 | 0.100 |
| E1 | 1.200 | 1.400 | 0.047 | 0.055 |
| e | 0.950 BSC | | 0.037 BSC | |
| L | 0.300 | 0.500 | 0.012 | 0.020 |
| θ | 0 | 8° | 0 | 8° |

X-ON Electronics

Largest Supplier of Electrical and Electronic Components

Click to view similar products for [Bipolar Transistors - BJT category](#):

Click to view products by [PAKER Microelectronics manufacturer](#):

Other Similar products are found below :

[BC559C](#) [MCH4017-TL-H](#) [MMBT-2369-TR](#) [BC546/116](#) [NJVMJD148T4G](#) [NTE16](#) [NTE195A](#) [IMX9T110](#) [2N4401-A](#) [2N4403](#) [2N6728](#)
[2SA1419T-TD-H](#) [2SA2126-E](#) [2SB1204S-TL-E](#) [FMC5AT148](#) [2N2369ADCSM](#) [2N2907A](#) [2N3904-NS](#) [2N5769](#) [2SC4618TLN](#) [CPH6501-](#)
[TL-E](#) [MCH4021-TL-E](#) [Jantx2N5416](#) [US6T6TR](#) [BAX18/A52R](#) [BC556/112](#) [IMZ2AT108](#) [MMST8098T146](#) [UMX21NTR](#) [MCH6102-TL-E](#)
[TTA1452B,S4X\(S](#) [2N3879](#) [NTE13](#) [NTE282](#) [NTE323](#) [NTE350](#) [NTE81](#) [JANTX2N2920L](#) [JANTX2N3735](#) [JANSR2N2222AUB](#)
[CMLT3946EG TR](#) [SNSS40600CF8T1G](#) [CMLT3906EG TR](#) [GRP-DATA-JANS2N2907AUB](#) [GRP-DATA-JANS2N2222AUA](#)
[MMDT3946FL3-7](#) [2N4240](#) [JANS2N3019](#) [MSB30KH-13](#) [2N2221AUB](#)