

NAiS

MOTION SENSOR (PASSIVE INFRARED TYPE)

MP MOTION SENSOR 'NaPiOn'

NaPiOn web page URL:
<http://www.napion.com/>

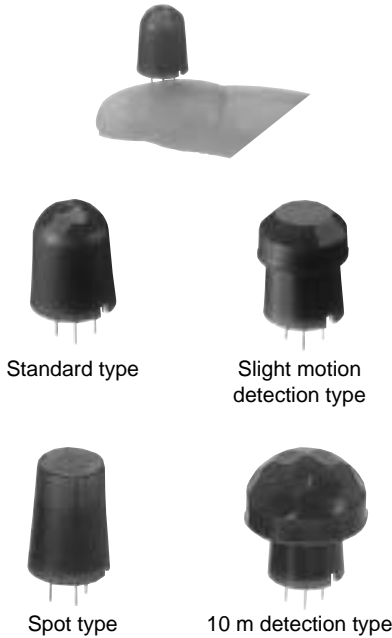

FEATURES

1. The world's smallest with a built-in amplifier

Extremely compact. Ideal for use in miniaturized devices.

2. Dual lens colors (white and black) are provided

With an ultrasmall design and dual lens colors (white and black), it is inconspicuous, allowing the user to select either white or black to match the equipment color. This provides greater flexibility in equipment design.

3. Both digital output and analog output (with adjustable sensitivity) are available.

Has a built-in amplifier, and can be connected directly to a microcomputer.

• Block diagram of the digital output circuit

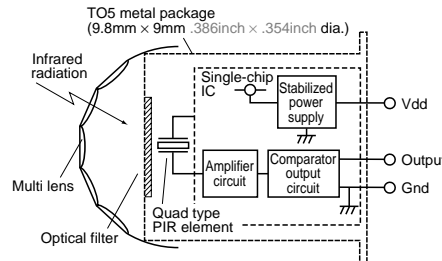

• Block diagram of the analog output circuit

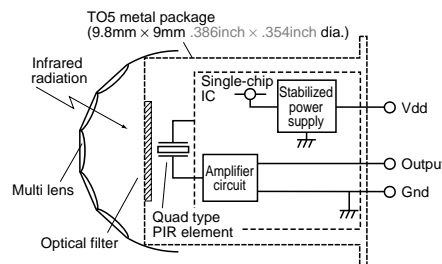

5. Detects even slight motion of a person

With our sensor, even slight motions made by people will be detected easily.

• Fine motion detection capability within approximately 2 meters of sensor.

Standard type:

Detects movement of approximately 30cm 11.811inch.

Slight motion detection type:

Detects movement of approximately 20cm 7.874inch.

6. Noise withstanding capability

Circuitry is contained in a TO5 metal package, providing at least twice the noise withstanding capability as conventional type.

• Comparison example of noise withstanding capability

	Distance at which motion sensor is not affected by cellular phone noise
Conventional type	Min. 1 to 2m 3.281 to 6.562ft
MP Motion Sensor	Min. 1 to 2cm .394 to .787inch

What is passive infrared type?

This sensor detects changes in infrared radiation which occur when there is movement by a person (or object) which is different in temperature from the surroundings.

- As this sensor detects temperature differences, it is well suited to detecting the motion of people by their body temperature.
- Wide sensing area.

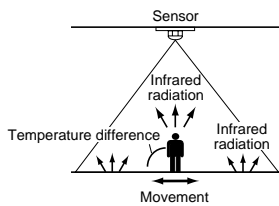

APPLICATIONS

1. Home appliances

Useful for saving energy in air conditioner, television, personal computer, or ventilator and air purifier

2. Amusement machine market

Useful for saving energy and for automated guidance in theme parks and large video games

3. Equipment in service market

Useful for automated guidance, automated announcements and energy saving in vending machines, ATMs, etc.

4. Lighting market

Automated on/off controls, etc. for lamps, desk lamps, indoor lights, halls, stairway lights, etc.

ORDERING INFORMATION

Output

- Digital output
- Analog output

Detection performance

- Standard detection type
- Slight motion detection type
- Spot detection type
- 10m detection type

Feature

- PC board mounting type

Operating voltage

- 5V DC

Lens color

- Black
- White

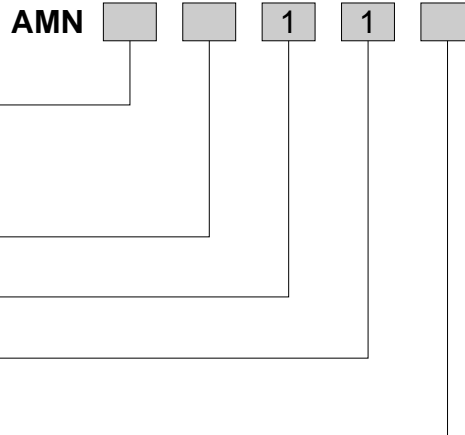

PRODUCT TYPES

1. Digital output

Rated operating voltage	Detection performance	Ambient temperature	Lens color	Part No.	Packing quantity	
					Inner	Outer
3 to 6 V DC	Standard detection type	-20 to +60°C -4 to +140°F	Black	AMN11111	50 pcs.	1,000 pcs.
			White	AMN11112		
	Slight motion detection type		Black	AMN12111		
			White	AMN12112		
	Spot detection type		Black	AMN13111		
			White	AMN13112		
	10m detection type		Black	AMN14111		
			White	AMN14112		

2. Analog output

Rated operating voltage	Detection performance	Ambient temperature	Lens color	Part No.	Packing quantity	
					Inner	Outer
4.5 to 5.5 V DC	Standard detection type	-20 to +60°C -4 to +140°F	Black	AMN21111	50 pcs.	1,000 pcs.
			White	AMN21112		
	Slight motion detection type		Black	AMN22111		
			White	AMN22112		
	Spot detection type		Black	AMN23111		
			White	AMN23112		
	10m detection type		Black	AMN24111		
			White	AMN24112		

PERFORMANCE

1. Detection performance

Items		Standard detection type	Slight motion detection type	Spot detection type	10m detection type	Conditions of objects to be detected
Rated detection distance* ^{Remark 1}		5m 16.404ft (Max.)	2m 6.562ft (Max.)	5m 16.404ft (Max.)	10m 32.808ft (Max.)	1. Detectable difference in temperature between the target and background for the spot type is more than 4°C 39.2°F. 2. Movement speed • Standard detection type/Spot detection type/ 10m detection type: 1.0 m/s • Slight motion detection type: 0.5 m/s 3. Detection object = human body (size is 700mm × 250mm 27.559inch × 9.843inch, but for the slight motion detection type the size is 200mm × 200mm 7.874inch × 7.874inch)
Detection range	Horizontal* ^{Remark 2}	100°	91°	38°	110°	
	Vertical* ^{Remark 2}	82°	91°	22°	93°	
	Detection zone* ^{Remark 3}	64 zones	104 zones	24 zones	80 zones	

2.

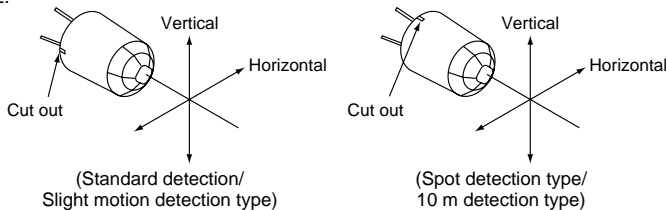

*Remarks 1. Depending on the difference in temperature between the background and detection target and the speed at which the target moves, these sensors may be capable of detection beyond the detection distances stated above. Nevertheless, they should be used within the prescribed detection distances. For further details, refer to the detection range diagram on page 7.
 3. Regarding of detection zone, please refer to "DETECTION PERFORMANCE" on page 7.

2. Rating (Measuring condition: ambient temp. = 25°C 77°F) (Common to All types)

Items	Specified value	Remarks
Power supply voltage	-0.3 to 7 V DC	
Usable ambient temperature	-20 to 60°C -4 to +140°F	No freezing and condensing at low temperature.
Storage temperature	-20 to 70°C -4 to +158°F	

3. Electrical characteristics (Measuring condition: ambient temp. = 25°C 77°F; operating voltage = 5V) (Common to All types)

1) Digital output

Items		Symbol	Specified value	Measured conditions	
Reted operating voltage	Minimum	Vdd	3.0 V DC		
	Typical		—		
	Maximum		6.0 V DC		
Reted consumption current (Standby)* ^{Remark}		Iw	170 μA	Iout = 0	
			300 μA		
Output (when detecting)	Current	Maximum	Iout	100 μA	Vout 7 Vdd-0.5
	Voltage	Minimum	Vout	Vdd -5	Open when not detecting
		Maximum		Vdd (Same as operating voltage)	
Circuit stability time		Typical	Twu	7 s	
		Maximum		30 s	

Remark: The current which is consumed during detection consists of the standby consumed current plus the output current.

MP Motion Sensor (AMN1)

2) Analog output

Items		Symbol	Specified value	Measured conditions
Reted operating voltage	Minimum	Vdd	4.5 V DC	
	Maximum		5.5 V DC	
Reted consumption current	Typical	Iw	0.17 mA	Iout = 0
	Maximum		0.3 mA	
Output current	Maximum	Iout	50 μ A	
Output voltage	Minimum	Vout	0 V	
	Typical		2.5 V	
	Maximum		Vdd	
Output offset average voltage	Minimum	Voff	2.3 V	Steady-state output voltage when not detecting
	Typical		2.5 V	
	Maximum		2.7 V	
Steady-state noise	Typical	Vn	130 m Vp-p	
	Maximum		300 m Vp-p	
Circuit stability time	Typical	Twu	7 s	
	Maximum		45 s	

Note: To set to the same detection performance as the digital type, set the output voltage to the offset voltage (2.5V) \pm 0.45V (i.e. 2.95V or more and 2.05V or less).

[Timing chart]

1) Digital output

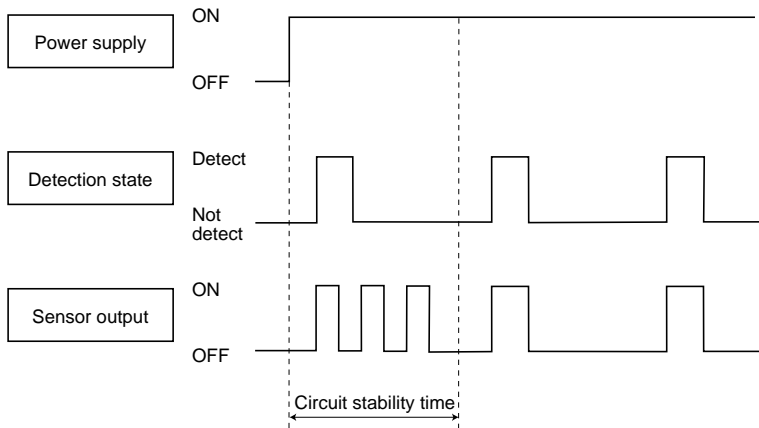

Remark: Circuit stability time: 45s max. (45s max. for the 10m detection type)

While the circuitry is stabilizing after the power is turned on, the sensor output is not fixed in the "on" state or "off" state. This is true regardless of whether or not the sensor has detected anything.

2) Analog output

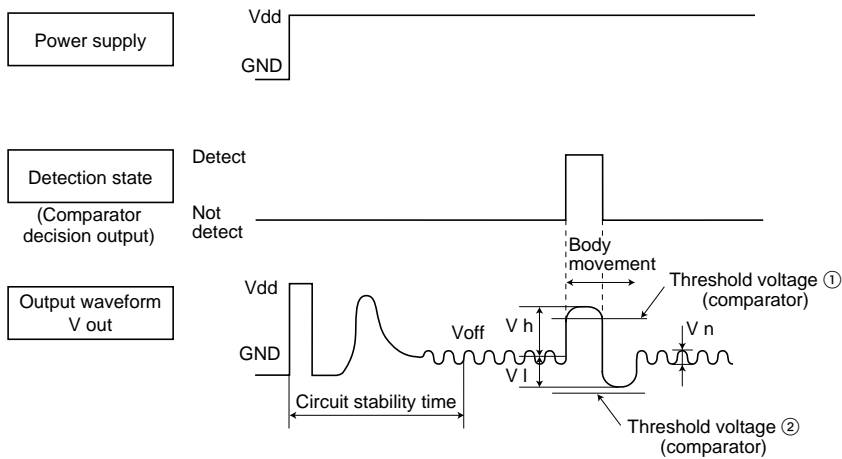

Remark: Circuit stability time: 30s max.

While the circuitry is stabilizing after the power is turned on, the sensor output is not fixed in the "on" state or "off" state. This is true regardless of whether or not the sensor has detected anything.

DETECTION PERFORMANCE

1. Standard detection type

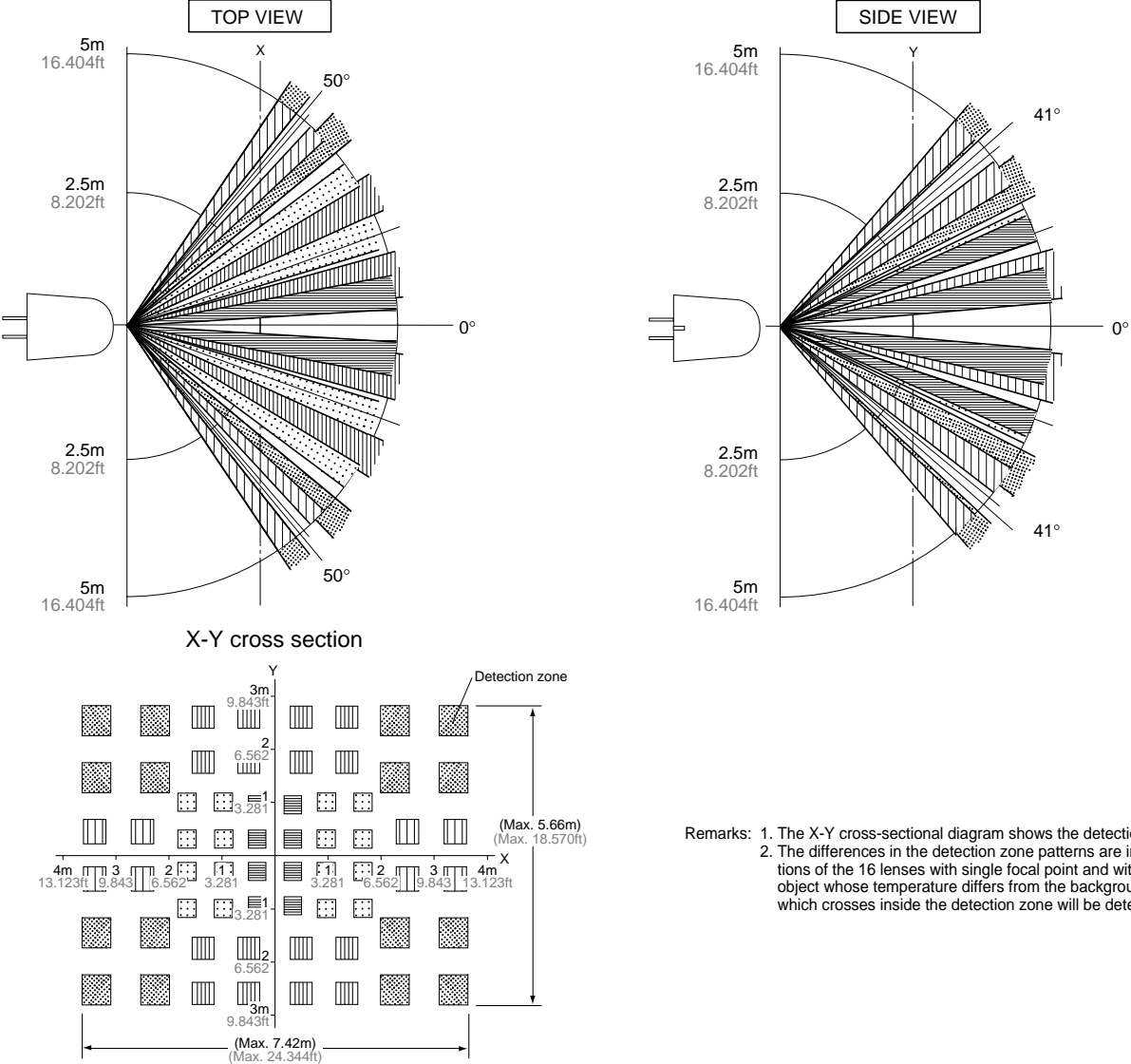

Remarks: 1. The X-Y cross-sectional diagram shows the detection area.
 2. The differences in the detection zone patterns are indicative of the projections of the 16 lenses with single focal point and with five optical axes. An object whose temperature differs from the background temperature and which crosses inside the detection zone will be detected.

2. Slight motion detection type

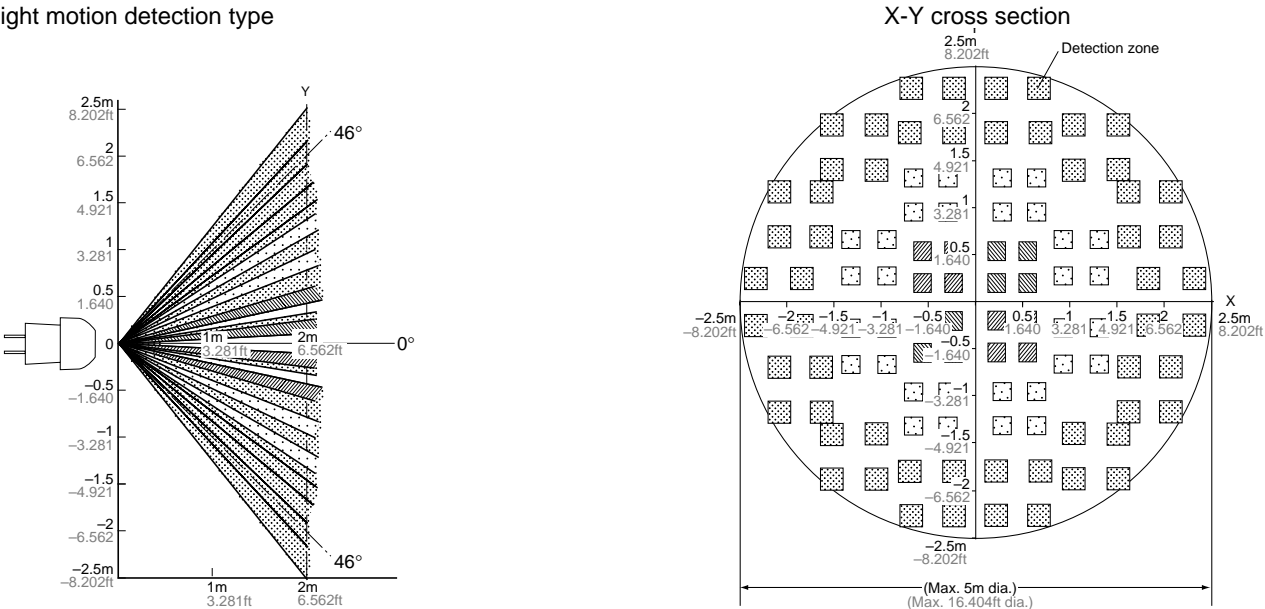

Remarks: 1. The X-Y cross-sectional diagram shows the detection area.
 2. The differences in the detection zone patterns are indicative of the projections of the 26 lenses with single focal point and with three optical axes. An object whose temperature differs from the background temperature and which crosses inside the detection zone will be detected.

MP Motion Sensor (AMN1)

3. Spot detection type

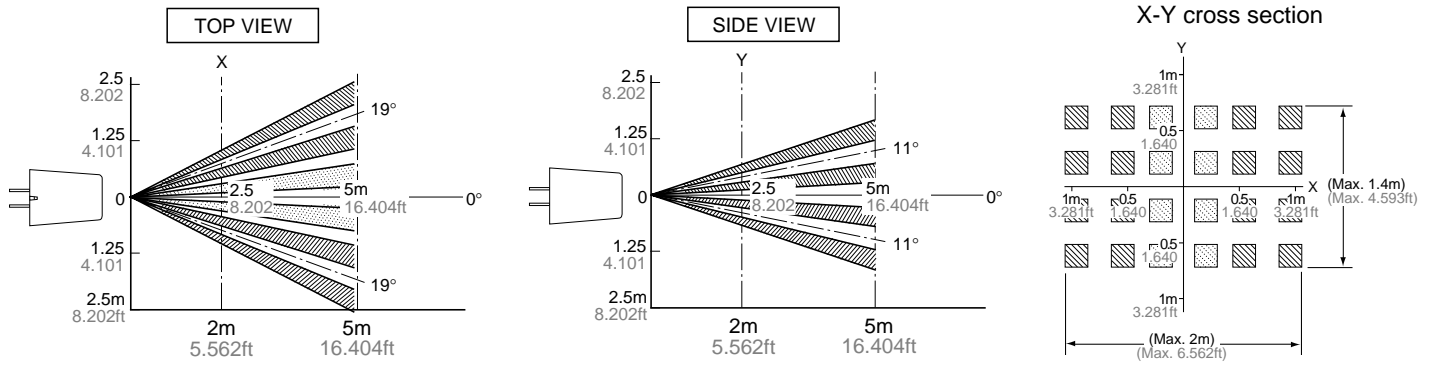

Remarks: 1. The X-Y cross-sectional diagram shows the detection area.
 2. The differences in the detection zone patterns are indicative of the projections of the 6 lenses with single focal point and with two optical axes. An object whose temperature differs from the background temperature and which crosses inside the detection zone will be detected.

4. 10m detection type

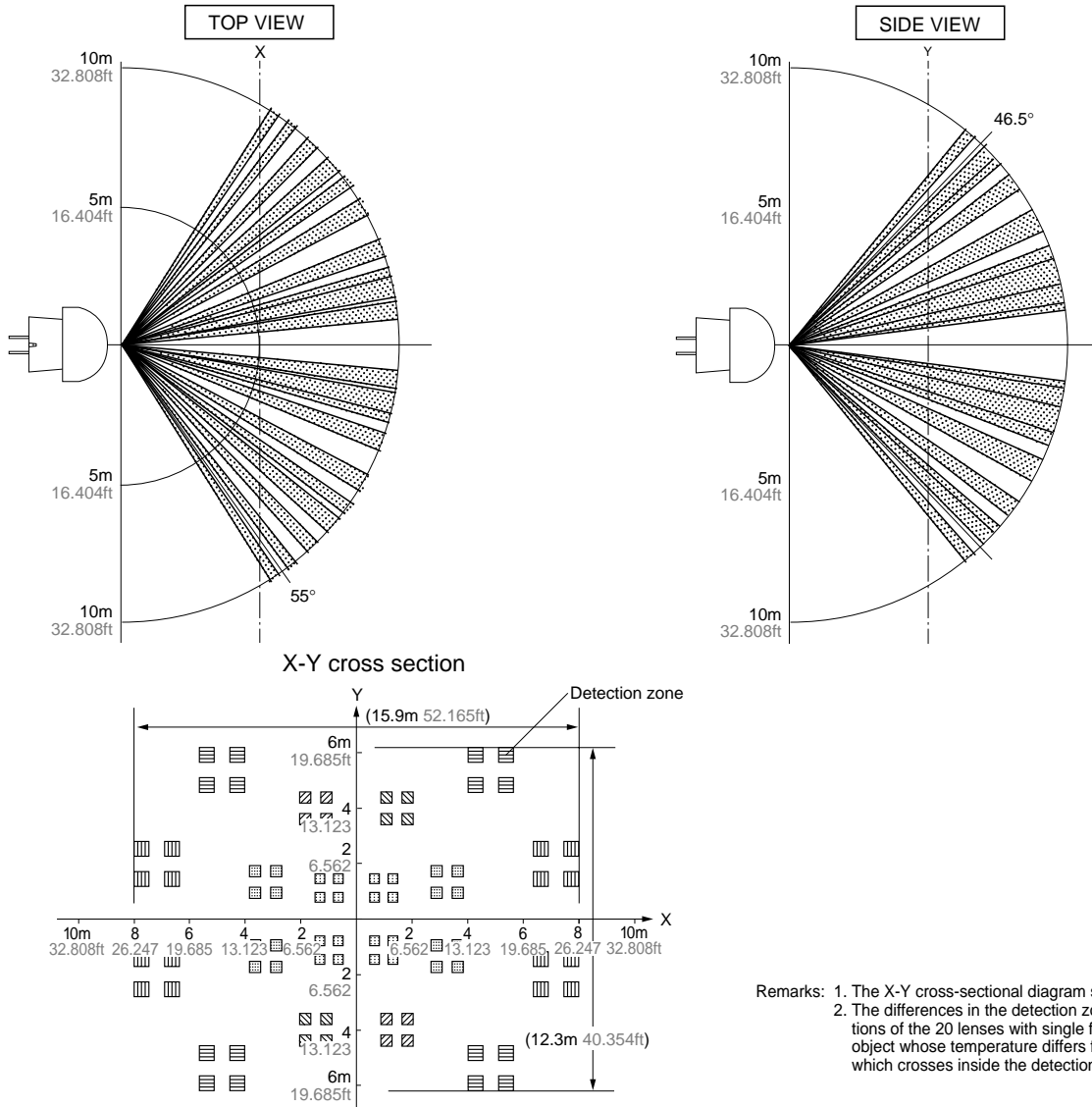

Remarks: 1. The X-Y cross-sectional diagram shows the detection area.
 2. The differences in the detection zone patterns are indicative of the projections of the 20 lenses with single focal point and with five optical axes. An object whose temperature differs from the background temperature and which crosses inside the detection zone will be detected.

5. Notes regarding the detection zone

The detection zone has the polarity shown in the diagram on the right. When targets enter both the + and - zones with the same timing, the signals are cancelled each other, thus in this case there is a possibility that the object cannot be detected at the maximum specified detection distance.

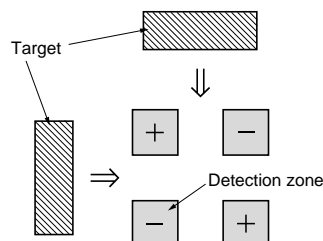

HOW TO USE

1. Wiring diagram

1) Digital output

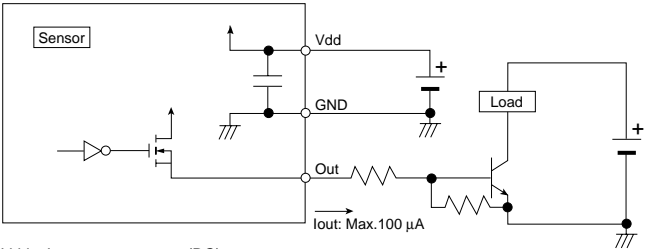

Vdd: Input power source (DC)
 GND: GND
 Out: Output (Comparator)

2) Analog output

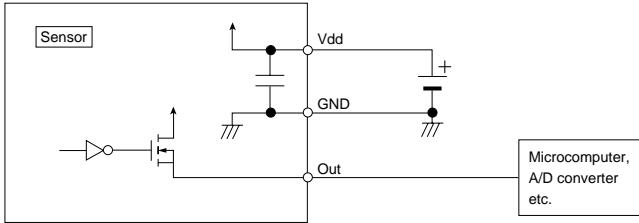

2. Timer circuit example

1) Digital output

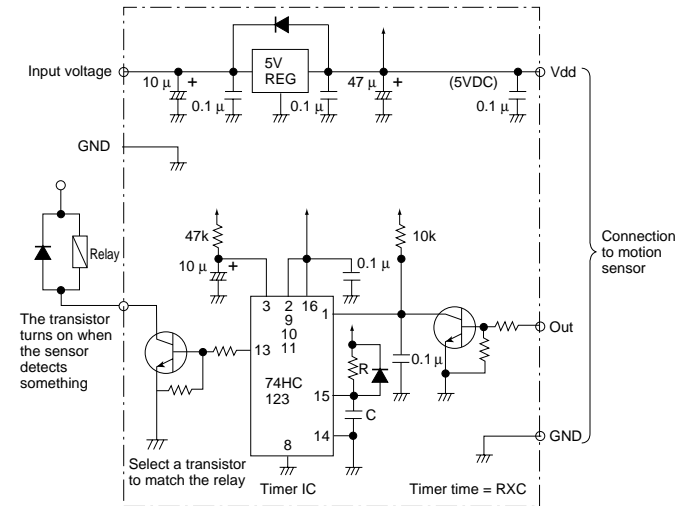

Note: This is the reference circuit which drives the MP motion sensor. Install a noise filter for applications requiring enhanced detection reliability and noise withstanding capability. Differences in the specifications of electronic components to which the units are connected sometimes affect their correct operation; please check the units' performance and reliability for each application.

2) Analog output

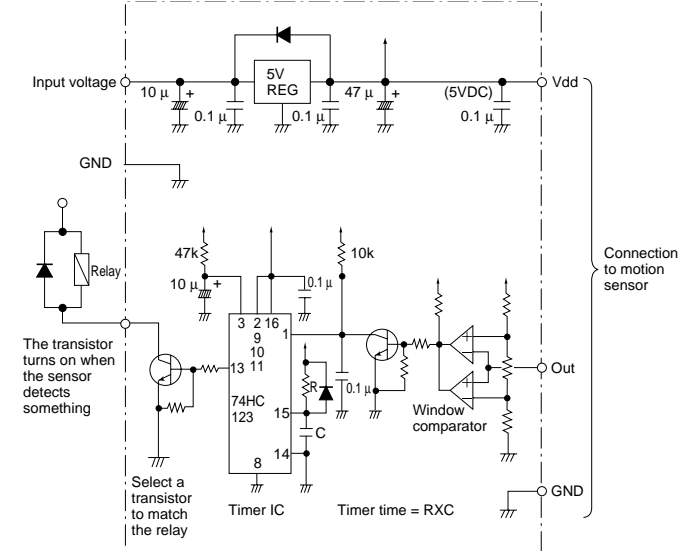

Note: This circuit is a sample of a drive circuit for the MP Motion Sensor. Its noise resistance and long-term reliability are not considered or investigated. To improve the detection reliability and noise resistance of the circuit, consider adding a noise filter. Matsushita Electric Works, Ltd. accepts no responsibility for damages resulting from the use of this circuit.

3. Installation

Install the sensor so that people will be entering from the X or Y direction shown below. If persons approach the sensor from the Z direction, detection distance will be shortened.

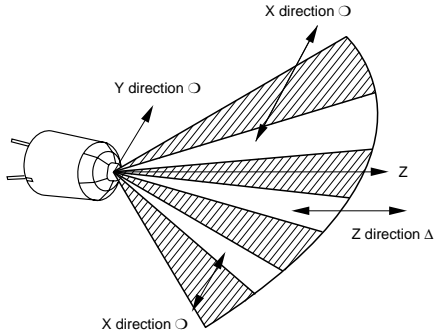

MP Motion Sensor (AMN1)

DIMENSIONS

mm inch General tolerance $\pm 0.5 \pm .020$

1. Standard detection type

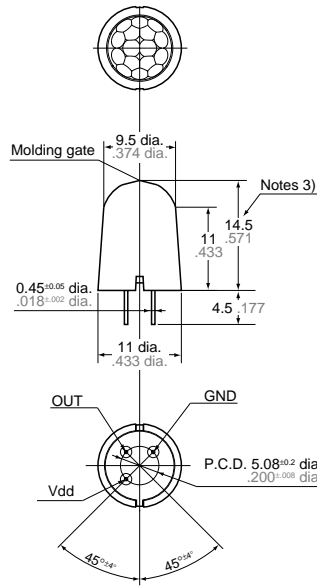
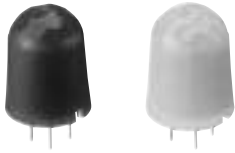

Recommended PC board pattern (BOTTOM VIEW)

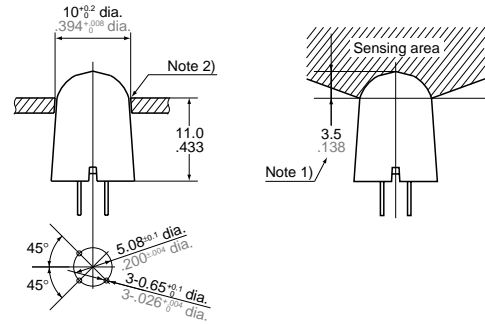

- Notes:
1. In order to ensure proper detection, install it with the lens exposed at least 3.5mm (.138inch).
 2. As for panel mounting hole, tapering or making a large size hole should be done.
 3. The height dimension does not include the remaining molding gate.

2. Slight motion detection type

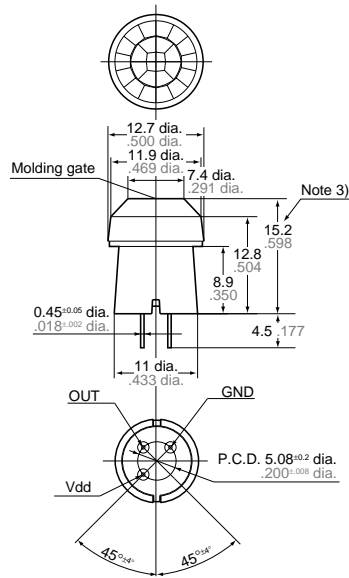
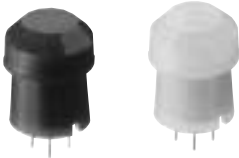

Recommended PC board pattern (BOTTOM VIEW)

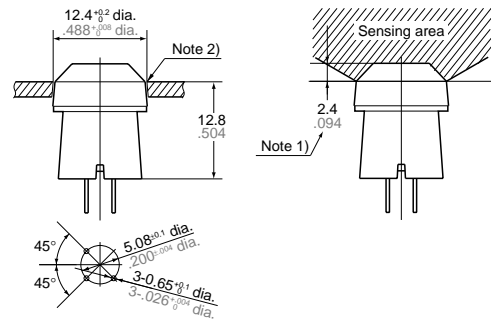

- Notes:
1. In order to ensure proper detection, install it with the lens exposed at least 2.4mm (.094inch).
 2. As for panel mounting hole, tapering or making a large size hole should be done.
 3. The height dimension does not include the remaining molding gate.

3. Spot detection type

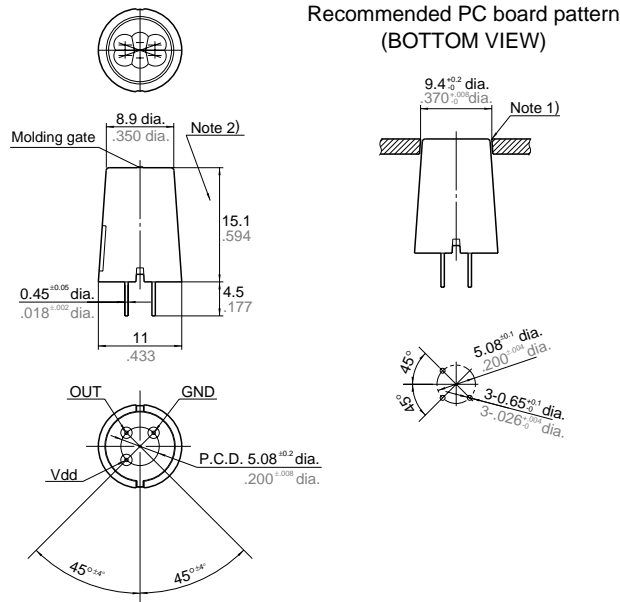

Notes: 1. As for panel mounting hole, tapering or making a large size hole should be done.
2. The height dimension does not include the remaining molding gate.

4. 10m detection type

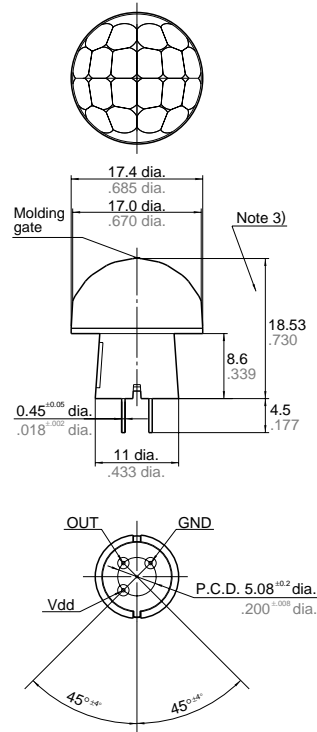

Notes: 1. In order to ensure proper detection, install it with the lens exposed at least 5.6mm (.220inch).
2. As for panel mounting hole, tapering or making a large size hole should be done.
3. The height dimension does not include the remaining molding gate.

mm inch General tolerance $\pm 0.5 \pm .020$

Recommended PC board pattern (BOTTOM VIEW)

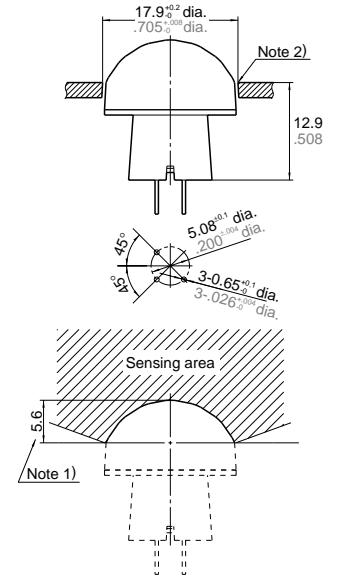

NOTES

1. Checkpoints relating to principle of operation

MP motion sensors are passive infrared sensors which detect changes in the infrared rays. They may fail to detect successfully if a heat source other than a human being is detected or if there are no temperature changes in or movement of a heat source. Care must generally be taken in the following cases. The performance and reliability of the sensors must be checked out under conditions of actual use.

<1> Cases where a heat source other than a human being is detected.

- 1) When a small animal enters the detection range.
- 2) When the sensor is directly exposed to sunlight, a vehicle's headlights, an incandescent light or some other source of far infrared rays.
- 3) When the temperature inside the detection range has changed suddenly due to the entry of cold or warm air from an air-conditioning or heating unit, water vapor from a humidifier, etc.

<2> Cases where it is difficult to detect the heat source

- 1) When an object made of glass, acrylic or other subject which far infrared rays have difficulty passing through is located between the sensor and what is to be detected.

- 2) When the heat source inside the detection range hardly moves or when it moves at high speed; for details on the movement speed, refer to the section on the performance ratings.

2. When the detection area becomes larger

When the difference between the ambient temperature and body temperature is large (more than 20°C 68°F), detection may occur in isolated areas outside the specified detection range.

3. Other handling cautions

- 1) Be careful not to allow dust or dirt to accumulate on the lens as this will adversely affect the detection sensitivity.
- 2) The lens is made of a soft material (polyethylene).
Avoid applying a load or impact since this will deform or scratch the lens, making proper operation impossible and causing a deterioration in its performance.
- 3) The sensor may be damaged if it is exposed to static with a voltage exceeding $\pm 200V$. Therefore, do not touch its terminals directly, and exercise adequate care in the handling of the sensor.
- 4) When the leads are to be soldered, solder them by hand for less than 3 seconds at a temperature of less than 350°C 662°F at the tip of the soldering iron. Avoid using a solder bath since this will causing a deterioration in the sensor's performance.

- 5) Do not attempt to clean the sensor. Cleaning fluid may enter inside the lens area causing a deterioration in performance.

- 6) When using the sensors with cables, it is recommended that cables which are shielded and as short as possible be used in order to safeguard against the effects of noise.

For the general precautions, refer to the Notes for Motion Sensors on page 24.

Global Network Services



North America

Aromat Corporation

Europe

Matsushita Electric Works

Asia Pacific

Matsushita Electric Works

China

Matsushita Electric Works

Japan

Matsushita Electric Works, Ltd. Automation Controls Group

Matsushita Electric Works

Please contact our Global Sales Companies in:



Europe

▶ Austria	Matsushita Electric Works Austria GmbH	Stojanstraße 12, A-2344 Maria Enzersdorf, Tel. (02236) 26846, Fax (02236) 46133, http://www.matsushita.at
▶ Benelux	Matsushita Electric Works Benelux B.V.	De Rijn 4, (Postbus 211), 5684 PJ Best, (5680 AE Best), Netherlands, Tel. (0499) 372727, Fax (0499) 372185, http://www.matsushita.nl
▶ France	Matsushita Electric Works France S.A.R.L.	B.P. 44, F-91371 Verrières le Buisson CEDEX, Tél. 01 60135757, Fax 01 60135758, http://www.matsushita-france.fr
▶ Germany	Matsushita Electric Works	Rudolf-Diesel-Ring 2, D-83607 Holzkirchen, Tel. (08024) 648-0, Fax (08024) 648-555, http://www.matsushita.de
▶ Ireland	Matsushita Electric Works UK Ltd.	Irish Branch Office, Waverley, Old Naas Road, Bluebell, Dublin 12, Republic of Ireland, Tel: (01) 4600969, Fax: (01) 4601131
▶ Italy	Matsushita Electric Works Italia s.r.l.	Via del Commercio 3-5 (Z.I. Ferlina), I-37012 Bussolengo (VR), Tel. (045) 6752711, Fax (045) 6700444, http://www.matsushita.it
▶ Portugal	Matsushita Electric Works España S.A.	Portuguese Branch Office, Avda 25 de Abril, Edificio Alvorada 5ºE, 2750-512 Cascais, Portugal, Tel. (21) 4828266, Fax (21) 4827421
▶ Scandinavia	Matsushita Electric Works Scandinavia AB	Sjöängsvägen 10, 19272 Sollentuna, Sweden, Tel. (08) 59476680, Fax (08) 59476690
▶ Spain	Matsushita Electric Works España S.A.	Barajas Park, San Severo 20, E-28042 Madrid, Tel. (91) 3293875, Fax (91) 3292976
▶ Switzerland	Matsushita Electric Works Schweiz AG	Grundstrasse 8, CH-6343 Rotkreuz, Tel. (041) 7997050, Fax (041) 7997055, http://www.matsushita.ch
▶ United Kingdom	Matsushita Electric Works UK Ltd.	Sunrise Parkway, Linford Wood East, Milton Keynes, MK14 6LF, England, Tel. (01908) 231555, Fax (01908) 231599, http://www.matsushita.co.uk

North & South America

▶ USA	Aromat Corporation Head Office USA	629 Central Avenue, New Providence, N.J. 07974, Tel. 1-908-464-3550, Fax 1-908-464-8513, http://www.aromat.com
-------	---	--

Asia

▶ China	Matsushita Electric Works Ltd. China Office	2013, Beijing Fortune, Building No. 5, Dong San Huan Bei Lu, Chaoyang District, Beijing, Tel. 86-10-6590-8646, Fax 86-10-6590-8647
▶ Hong Kong	Matsushita Electric Works Ltd. Hong Kong	Rm1601, 16/F, Tower 2, The Gateway, 25 Canton Road, Tsimshatsui, Kowloon, Hong Kong, Tel. (852) 2956-3118, Fax (852) 2956-0398
▶ Japan	Matsushita Electric Works Ltd. Automation Controls Group	1048 Kadoma, Kadoma-shi, Osaka 571-8686, Japan, Tel. 06-6908-1050, Fax 06-6908-5781, http://www.mew.co.jp/e-acg/
▶ Singapore	Matsushita Electric Works Pte. Ltd. (Asia Pacific)	101 Thompson Road, #25-03/05, United Square, Singapore 307591, Tel. (65) 255-5473, Fax (65) 253-5689

X-ON Electronics

Largest Supplier of Electrical and Electronic Components

Click to view similar products for [Board Mount Motion & Position Sensors](#) category:

Click to view products by [Panasonic](#) manufacturer:

Other Similar products are found below :

[SV03A103AEA01B00](#) [601HE0000B01](#) [6SS4](#) [IRA-S510ST01](#) [KMA221J](#) [XL-10043](#) [F02008062](#) [M10-JK8002C](#) [UM7-LT ORIENTATION SENSOR](#) [UM7 ORIENTATION SENSOR](#) [AMN33111J](#) [MTS-360-1A-C0000-ERA360-05E](#) [F01551006](#) [AMN11111](#) [AMN24112](#) [AMN31111](#) [AMN31112](#) [AMN34112](#) [AMN34111](#) [AMN23111](#) [SV03A103AEA01R00](#) [EKMC1693113](#) [EKMB1303111K](#) [EKMB1293112](#) [PST360-11302-1P-C0000-ERA360-24E-F100](#) [AMBA340215](#) [AMBA210205](#) [AMA115915](#) [A1324LLHLTT](#) [MLX91204KDC-ABA-001-SP](#) [EKMC1605111](#) [MLX90380LDC-BAB-120-SP](#) [02183000-000](#) [3382H-1-104](#) [EKMB1104111](#) [EKMB1204111](#) [EKMB1305111K](#) [EKMC1604112](#) [EKMB1305112K](#) [EKMB1205111](#) [EKMB1205112](#) [AMBA240202](#) [EKMB1304113K](#) [EKMB1105111](#) [EKMB1105112](#) [EKMC1693112](#) [EKMC1605112](#) [MLX90316EDC-BCG-000-SP](#) [EKMB1305113K](#) [AMBA345912](#)