AN33017UA

Evaluation Board Manual

Panasonic Corporation
Automotive & Industrial Systems Company
Semiconductor Business Division

AN33017UA Evaluation board (front side)

This is a two layer circuit board. The front side is shown below. (The back side is shown on the next page.)

SYNC input terminal
(external clock input)

SW1: Enable control switch
Upper side (high): DCDC ON
Lower side (low) : DCDC OFF

JPFLAG
If you connect this jumper switch, the FLAG pin will be connected to VREG(4.9V) via a 200k Ω -register.

FLAG
This pin can check FLAG output.

SW2: TL_CTRL control switch

TL_CTRL Pin connection	The condition that IC keep SCP or OCP over setting time by TL		
	FLAG Pin	DCDC Operation	DCDC Return method
(Upper side: High) Connect to VREG	Pull-down	Continue	After release abnormal state, IC is continue to operate. (However, FLAG pin keep Pull-down state)
(Lower side: Low) Connect to GND	Pull-down	Stop	IC is reset by EN pin.

SW3: OCPDET switch
If the difference voltage between R_SENSE is exceed below value, FLAG output change H \rightarrow L.
Upper side (high) :75mV (1.5A@50m Ω)
Lower side (low) :125mV (2.5A@50m Ω)

Labels on the board: VCC, GND, Input capacitor, SBD, VREG capacitor, SS, CT capacitor, Snubber circuit, Coil, BT capacitor, Current detect resistor (R_SENSE), DCDC output capacitor, Load Resistor, DCDC output, TL_CTRL pin, EN pin, TEST(OCPDET) pin, CFB adjusting resistor, TL capacitor, VREG, CVCC1, CVCC2, CVCC3, CVCC4, CVCC5, CVCC6, CVCC7, CVCC8, CVCC9, CVCC10, CVCC11, CVCC12, CVCC13, CVCC14, CVCC15, CVCC16, CVCC17, CVCC18, CVCC19, CVCC20, CVCC21, CVCC22, CVCC23, CVCC24, CVCC25, CVCC26, CVCC27, CVCC28, CVCC29, CVCC30, CVCC31, CVCC32, CVCC33, CVCC34, CVCC35, CVCC36, CVCC37, CVCC38, CVCC39, CVCC40, CVCC41, CVCC42, CVCC43, CVCC44, CVCC45, CVCC46, CVCC47, CVCC48, CVCC49, CVCC50, CVCC51, CVCC52, CVCC53, CVCC54, CVCC55, CVCC56, CVCC57, CVCC58, CVCC59, CVCC60, CVCC61, CVCC62, CVCC63, CVCC64, CVCC65, CVCC66, CVCC67, CVCC68, CVCC69, CVCC70, CVCC71, CVCC72, CVCC73, CVCC74, CVCC75, CVCC76, CVCC77, CVCC78, CVCC79, CVCC80, CVCC81, CVCC82, CVCC83, CVCC84, CVCC85, CVCC86, CVCC87, CVCC88, CVCC89, CVCC90, CVCC91, CVCC92, CVCC93, CVCC94, CVCC95, CVCC96, CVCC97, CVCC98, CVCC99, CVCC100.

AN33017UA Evaluation board (back side)

This is a two layer circuit board. The back side is shown below. (The front side is shown on the previous page.)

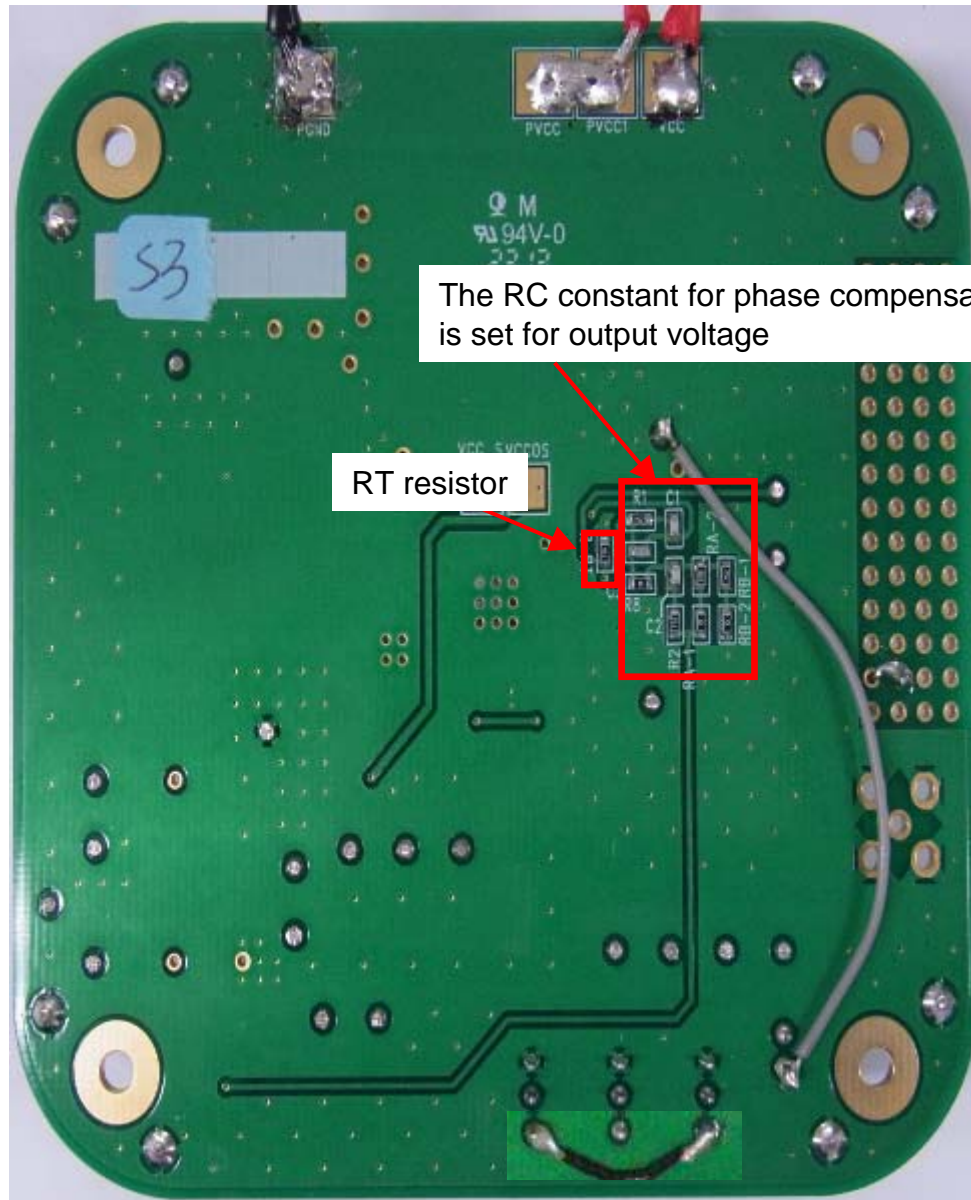

AN33017UA Evaluation board (schematic)

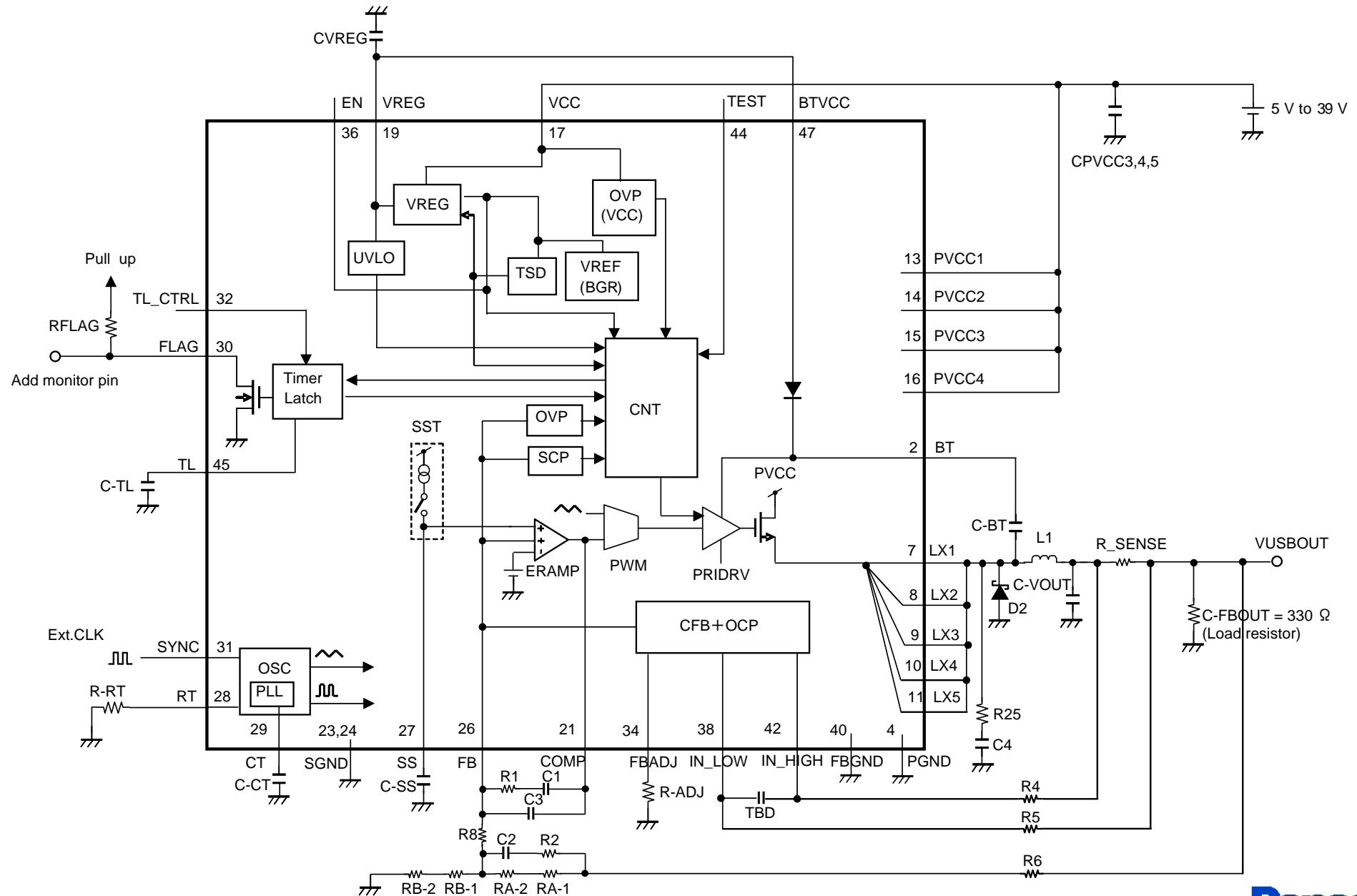

AN33017UA Evaluation board (components)

The BOM of this board is shown below.

Switching frequency set 490kHz (R_RT=130kΩ), Over current set 2.5A (TEST pin = Low).

Table 1 : component on the evaluation board (reference)

Board Component Name	Part Name	Size	Value	Maker	Description
C-BT,C-CT,C-SS,C-TL	GCM188R11C104KA01J	JIS1608_[EIA0603]	0.1uF	Murata	Setting Capacitor
C1	GCM1882C1H222JA01J	JIS1608_[EIA0603]	2.2nF	Murata	Compensation Capacitor
C2	GCM1882C1H471JA01J	JIS1608_[EIA0603]	470pF	Murata	Compensation Capacitor
C3	GCM1882C1H270JA01J	JIS1608_[EIA0603]	27pF	Murata	Compensation Capacitor
C4	GRM188B11H472KA01	JIS1608_[EIA0603]	4700pF	Murata	Snubber Capacitor
CVREG	GCM188R71C105KA49J	JIS1608_[EIA0603]	1uF	Murata	VREG Capacitor
CPVCC3,4,5	CKG57NX7R1H226MT	JIS5750_[EIA2220]	22uF	TDK	Input Capacitor
C-VOUT	TMK325C7226MM-T	JIS3225_[EIA1210]	22uF	TAIYO,YUDEN	Output Capacitor
L1	CDRH8D43-100NC	8.3(L) x 8.3(W)	10uH	SUMIDA	Inductor
IC1	AN33017UA	9.0(L) x 9.0(W)	-	Panasonic	1ch DCDC Converter
D2	DB24602	3.8(L) x 2.4(W)	-	Panasonic	Schottky Diode
R1	ERA3AEB752V	JIS1608_[EIA0603]	R=7.5K	Panasonic	Compensation & Feedback Resistor
R2	ERA3AEB152V	JIS1608_[EIA0603]	R=1.5K	Panasonic	Compensation & Feedback Resistor
R25	ERJ8GEYJ151V	JIS1608_[EIA0603]	R=150	Panasonic	Snubber Resistor
RA-2	ERA3AEB303V	JIS1608_[EIA0603]	R=30K	Panasonic	Compensation & Feedback Resistor
RA-1	ERJ3GEY0R00V	JIS1608_[EIA0603]	R=0	Panasonic	Compensation & Feedback Resistor
RB-1	ERA3AEB752V	JIS1608_[EIA0603]	R=7.5K	Panasonic	Compensation & Feedback Resistor
RB-2	ERJ3GEY0R00V	JIS1608_[EIA0603]	R=0	Panasonic	Compensation & Feedback Resistor
RFLAG	ERA3AEB204V	JIS1608_[EIA0603]	R=200K	Panasonic	Pull-up Resistor
R-RT	ERA3AEB134V	JIS1608_[EIA0603]	R=130K	Panasonic	OSC Setting Resistor
R-ADJ	ERA3AEB123V	JIS1608_[EIA0603]	R=12K	Panasonic	CFB Adjust Resistor
R4, R5, R6, R8	ERJ3GEY0R00V	JIS1608_[EIA0603]	R=0	Panasonic	0 ohm Resistor (for evaluation)
C-FBOUT	ERJ3GEYJ331	JIS1608_[EIA0603]	R=330	Panasonic	Load Resistor
R_SENSE	ERJ8BWFR050V	JIS3216_[EIA1206]	R=50m	Panasonic	OCP Sense Resistor

Note: The specifications of the BOM are reference values. Other components might be mounted depending on target values of output voltage, frequency, etc.

documents separately on terms of use etc.: Special applications (such as for in-vehicle equipment, airplanes, aerospace, automotive equipment, traffic signaling equipment, combustion equipment, medical equipment and safety devices) in which exceptional quality and reliability are required, or if the failure or malfunction of the products may directly jeopardize life or harm the human body.

Unless exchanging documents on terms of use etc. in advance, it is to be understood that our company shall not be held responsible for any damage incurred as a result of or in connection with your using the products described in this book for any special application.

- (4) The products and product specifications described in this book are subject to change without notice for modification and/or improvement. At the final stage of your design, purchasing, or use of the products, therefore, ask for the most up-to-date Product Standards in advance to make sure that the latest specifications satisfy your requirements.
- (5) When designing your equipment, comply with the range of absolute maximum rating and the guaranteed operating conditions (operating power supply voltage and operating environment etc.). Especially, please be careful not to exceed the range of absolute maximum rating on the transient state, such as power-on, power-off and mode-switching. Otherwise, we will not be liable for any defect which may arise later in your equipment.
Even when the products are used within the guaranteed values, take into the consideration of incidence of break down and failure mode, possible to occur to semiconductor products. Measures on the systems such as redundant design, arresting the spread of fire or preventing glitch are recommended in order to prevent physical injury, fire, social damages, for example, by using the products.
- (6) Comply with the instructions for use in order to prevent breakdown and characteristics change due to external factors (ESD, EOS, thermal stress and mechanical stress) at the time of handling, mounting or at customer's process. We do not guarantee quality for disassembled products or the product re-mounted after removing from the mounting board.
When using products for which damp-proof packing is required, satisfy the conditions, such as shelf life and the elapsed time since first opening the packages.
- (7) When reselling products described in this book to other companies without our permission and receiving any claim of request from the resale destination, please understand that customers will bear the burden.
- (8) This book may be not reprinted or reproduced whether wholly or partially, without the prior written permission of our company.

X-ON Electronics

Largest Supplier of Electrical and Electronic Components

Click to view similar products for [Other Development Tools](#) category:

Click to view products by [Panasonic](#) manufacturer:

Other Similar products are found below :

[DS100BR410EVK-4/NOPB](#) [BK0004](#) [BK0012](#) [SN65MLVD2-3EVM](#) [DS80EP100-EVK](#) [MAX9684EVKIT#](#) [MAX4952AEVKIT+](#) [ESD-EVM-001](#) [MAX14842EVKIT+](#) [EVAL01-HMC749LC3C](#) [410-320](#) [TPD6F002-Q1EVM](#) [DS80PCI800EVK/NOPB](#) [118777-HMC722LC3C](#) [118777-HMC723LC3C](#) [118777-HMC678LC3C](#) [DC1765A-A](#) [125614-HMC851LC3C](#) [TPD1E05U06DPYEVM](#) [SN65LVDM31-32BEVM](#) [DC2062A-A](#) [NB4N855SMEVB](#) [LMH6321MR-EVAL/NOPB](#) [EVAL01-HMC747LC3C](#) [4537](#) [DK-M3F-1.8-TRK-1.5-S](#) [DK-M3-FS-1.8-1.5-M12/16](#) [DK-M3L-1.8-TRK-6.0-S](#) [DK-M3-LS-1.8-6](#) [ADALM1000](#) [ADALP2000](#) [EVAL-CN0202-SDPZ](#) [EVAL-CN0203-SDPZ](#) [EVAL-CN0204-SDPZ](#) [EVAL-CN0209-SDPZ](#) [EVAL-CN0225-SDPZ](#) [EVAL-CN0229-SDPZ](#) [EVAL-CN0251-SDPZ](#) [EVAL-CN0272-SDPZ](#) [EVAL-CN0301-SDPZ](#) [EVAL-CN0325-SDPZ](#) [EVAL-CN0355-PMDZ](#) [EVAL-CN0364-SDPZ](#) [EVAL-SDP-CB1Z](#) [DS1964SEVKIT#](#) [MAX14611EVKIT#](#) [MAX22088EVKIT#](#) [MAX4951AEEVKIT+](#) [MAXREFDES60#](#) [MAXREFDES61#](#)