

Sine-wave PWM drive system and rotor position detection method by 1-Hall-sensor
1-Hall-Sensor Driver IC for 3-phase Brushless Motor

FEATURES

- Supply voltage range: 6.0 V to 26.4 V
- Built-in 5-V regulator
- 3-phase full-wave sine-wave PWM drive by 1-Hall-sensor
- VSP pin linear input
- Drive phase shift control
- Rotation direction selectable (Forward/Reverse)
- FG pulse divide selectable
- Stand-by mode
- Various protection functions: under voltage lock out (UVLO), over voltage lock out (OVLO), thermal protection, over load protection, and over current protection
- 24-pin plastic quad flat non-lead package (QFN type, size: 4 mm × 4 mm)

APPLICATIONS

- Driver IC for 3-phase brushless fan motor

DESCRIPTION

AN44140A is a driver IC for 3-phase brushless motor optimized for fan motors. By employing the rotor position detector and sine wave PWM drive by 1-Hall-sensor, this IC achieves component reduction and miniaturization of motor set as well as motor drive at low noise, low vibration and low power consumption.



SIMPLIFIED APPLICATION

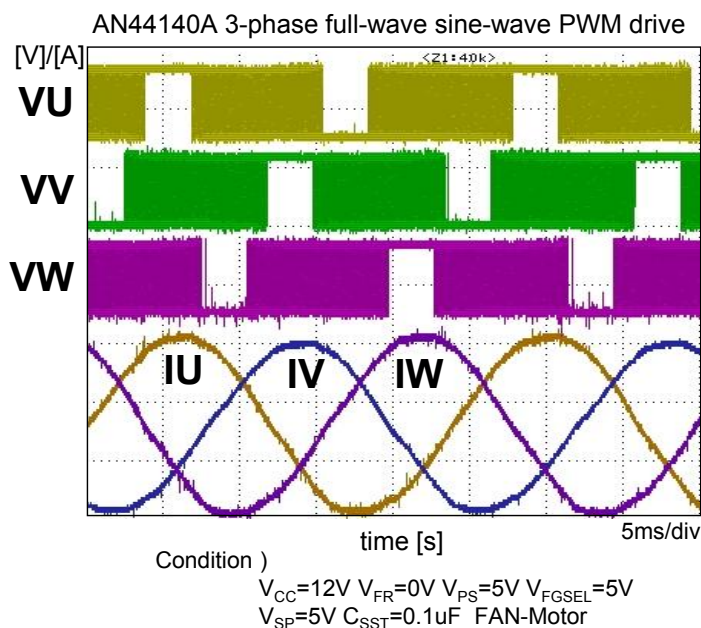
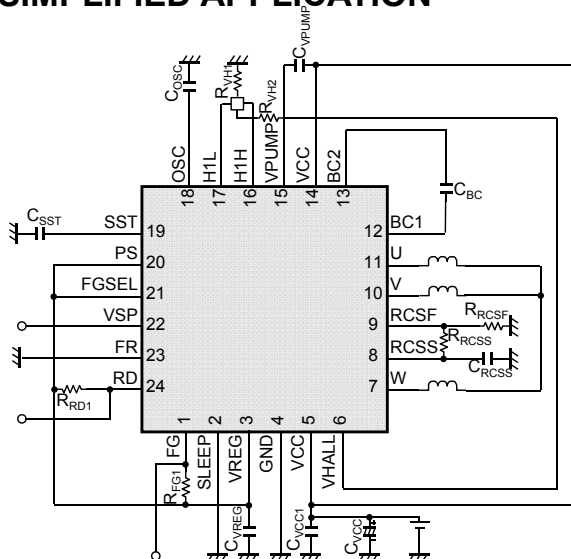

Notes

This application circuit is an example. The operation of mass production set is not guaranteed. You should perform enough evaluation and verification on the design of mass production set. You are fully responsible for the incorporation of the above application circuit and information in the design of your equipment.

ABSOLUTE MAXIMUM RATINGS

Parameter	Symbol	Rating	Unit	Note
Supply voltage	V_{CC}	28	V	*1
Operating ambient temperature	T_{opr}	-40 to +95	°C	*2
Storage temperature	T_{stg}	-55 to +150	°C	*2
Input Voltage Range	$V_{SLEEP}/V_{H1H}/V_{H1L}/V_{PS}/V_{FGSEL}$ V_{VSP}/V_{FR}	-0.3 to 6.0	V	—
	V_{RCSS}/V_{SST}	-0.3 to 6.0	V	*3
Output Voltage Range	V_{FG}/V_{RD}	-0.3 to 6.0	V	—
	V_{VREG}/V_{RCSF}	-0.3 to 6.0	V	*3
	V_{BC1}	28	V	*3
	V_{BC2}/V_{pump}	37	V	*3
	V_{VHALL}	-0.3 to $V_{VREG} + 0.3$	V	*3
Input Current Range	$I_U/I_V/I_W$	± 2.2	A	*4
	I_{FG}/I_{RD}	5	mA	—
	I_{VHALL}/I_{VREG}	-10	mA	*4, *5
ESD	HBM (Human Body Model)	2	kV	—

Notes) This product may sustain permanent damage if subjected to conditions higher than the above stated absolute maximum rating. This rating is the maximum rating and device operating at this range is not guarantee able as it is higher than our stated recommended operating range. When subjected under the absolute maximum rating for a long time, the reliability of the product may be affected.

- *1: The values are defined, provided that the IC is used within all of the above absolute maximum ratings including the power dissipation.
- *2: All ratings are for $T_a = 25^\circ\text{C}$, except the power dissipation, operating ambient temperature, and storage temperature.
- *3: Applying external voltage into these pins is prohibited. Set them not to exceed the ratings even in transient state.
- *4: Applying external current into these pins is prohibited. Set them not to exceed the ratings even in transient state.
- *5: The rated current of VREG and VHALL is defined as the sum of VREG and VHALL currents.

POWER DISSIPATION RATING

Condition	θ_{j-a}	θ_{j-c}	PD (Ta=25 °C)	PD (Ta=70 °C)
24 pin Plastic Quad Flat Non-leaded Package (QFN type)	97.7°C/W	10.5°C/W	1.279°C/W	0.818°C/W

Note). For the actual usage, please refer to the PD-Ta characteristics diagram in the package specification, follow the power supply voltage, load and ambient temperature conditions to ensure that there is enough margin and the thermal design does not exceed the allowable value.

- *1: Glass-Epoxy Substrate (2 Layers) : 50×50×0.8t (mm) , heat dissipation fin: Dai-pad , Soldered.



CAUTION

Although this has limited built-in ESD protection circuit, but permanent damage may occur on it. Therefore, proper ESD precautions are recommended to avoid electrostatic damage to the MOS gates

RECOMMENDED OPERATING CONDITIONS

Parameter	Symbol	Min.	Typ.	Max.	Unit	Note
Supply voltage range	V_{CC}	6.0	—	26.4	V	—
Input Voltage Range	V_{SLEEP}	0	—	V_{VREG}	V	*1
	V_{RCSS}	0	—	V_{VREG}	V	*1
	V_{H1H}	0	—	V_{VREG}	V	*1
	V_{H1L}	0	—	V_{VREG}	V	*1
	V_{PS}	0	—	V_{VREG}	V	*1
	V_{FGSEL}	0	—	V_{VREG}	V	*1
	V_{VSP}	0	—	V_{VREG}	V	*1
	V_{FR}	0	—	V_{VREG}	V	*1
External Constants	C_{VCC}	—	47 μ	—	F	*2
	C_{VCC1}	—	0.1 μ	—	F	*2
	C_{VREG}	—	0.1 μ	—	F	*2
	C_{SST}	47.0p	0.1 μ	—	F	*2
	C_{BC}	—	0.01 μ	—	F	*2
	C_{VPUMP}	—	0.01 μ	—	F	*2
	C_{OSC}	360p	470p	—	F	*2
	R_{RCSF}	0.15	0.22	—	Ω	*2, *3
	R_{RCSS}	—	1k	—	Ω	*2
	C_{RCSS}	—	100p	—	F	*2
	R_{VH1}	—	1k	—	Ω	*2
	R_{VH2}	—	1k	—	Ω	*2

Notes) *1 For detention range of input control voltage, refer to the Electrical Characteristics on page 4-5, and the Operation on page17.

*2 This value is an example. Operation of mass production set is not guaranteed. Perform enough evaluation and verification on the design of mass production set.

*3 A value less than this resistance is prohibited. If you set below this minimum value, there is a possibility to working the latch function to protect the device against thermal destruction which is caused by the external factor (Heat dissipation of the substrate, the line impedance, etc...) or inner factor(Variation of the threshold, etc...).

ELECTRICAL CHARACTERISTICS

V_{CC}=12V,

Note) T_a = 25°C±2°C unless otherwise noted.

Parameter	Symbol	Condition	Limits			Unit	Note
			Min	Typ	Max		
Circuit Current							
V _{CC} current	I _{CC1}	—	6.5	8.5	11	mA	—
V _{CC} current at stand-by mode	I _{CC2}	SLEEP= L, V _{VSP} = 0 V	4	6	8	mA	—
V _{CC} current at sleep mode	I _{CC3}	SLEEP = H	—	—	150	μA	—
Regulator Block							
VREG voltage	V _{VREG}	—	4.7	5	5.3	V	—
Output impedance	Z _{VREG}	I = -10 mA	—	—	10	Ω	—
FG Block							
FG output (low voltage)	V _{FG_L}	I _{FG} = 1.0 mA	—	0.1	0.3	V	—
RD Block							
RD output (low voltage)	V _{RD_L}	I _{RD} = 1.0 mA	—	0.1	0.3	V	—
Power Block							
On resistance	R _{ONHL}	I = 0.25 A	0.8	1.2	1.6	Ω	—
Diode forward voltage	V _{DI}	I = 0.25 A	0.6	0.8	1	V	—
Motor Lock Protection							
Lock detection time	t _{ROCK1}	—	0.35	0.5	0.65	s	—
Lock release time	t _{ROCK2}	—	3.5	5	6.5	s	—
Lock protection ratio	PR _{RATIO}	—	9	10	11	—	—
Over Current Protection							
Over current detection level	V _{CL}	—	0.225	0.250	0.275	V	—
Hall Block							
Input dynamic range	V _{HALL}	—	0.5	—	3.5	V	—
Input bias current	I _{HALL}	—	-2	0	2	μA	—
Hysteresis level: L → H	V _{HYS1}	—	1	7.5	14	mV	—
Hysteresis level: H → L	V _{HYS2}	—	1	7.5	14	mV	—
Hysteresis width	V _{OVhys}	—	7.5	15	23	mV	—
VSP Input							
VSP voltage of Minimum torque	V _{VSP_L}	Absolute value	0.45	0.55	0.65	V	—
		Ratio to V _{VREG}	0.09	0.11	0.13	V/V	—
VSP voltage of Maximum torque	V _{VSP_H}	Absolute value	4.3	4.5	4.7	V	—
		Ratio to V _{VREG}	0.86	0.9	0.94	V/V	—
VSP input current	I _{VSP}	—	-0.1	0	0.1	μA	—

ELECTRICAL CHARACTERISTICS (continued)

V_{CC}=12V,

Note) T_a = 25°C±2°C unless otherwise noted.

Parameter	Symbol	Condition	Limits			Unit	Note
			Min	Typ	Max		
OSC Triangle Wave Oscillator (PWM Frequency)							
Oscillation frequency	F _{OSC}	C _{OSC} = 470 pF	48.0	56.5	65.0	kHz	—
FR							
Low-level input voltage	V _{FRL}	—	—	—	1.0	V	—
High-level input voltage	V _{FRH}	—	2.0	—	—	V	—
Open-circuit voltage	V _{FRZ}	—	3.1	3.3	3.5	V	—
Input bias current	I _{INFR}	V _{FR} =0V	47.7	66.0	100.0	μA	—
PS							
Low-level input voltage	V _{PSL}	Ratio to V _{VREG}	0.2	0.25	0.3	V/V	—
High-level input voltage	V _{PSH}	Ratio to V _{VREG}	0.6	0.7	0.8	V/V	—
Open-circuit voltage	V _{PSZ}	Ratio to V _{VREG}	0.45	0.5	0.55	V/V	—
Input bias current	I _{INPS}	V _{PS} =0V	36.2	50.0	75.7	μA	—
FGSEL							
Low-level input voltage	V _{FGSELL}	Ratio to V _{VREG}	0.2	0.25	0.3	V/V	—
High-level input voltage	V _{FGSELH}	Ratio to V _{VREG}	0.6	0.7	0.8	V/V	—
Open-circuit voltage	V _{FGSELZ}	Ratio to V _{VREG}	0.45	0.5	0.55	V/V	—
Input bias current	I _{INPS}	V _{FGSEL} =0V	36.2	50.0	75.7	μA	—
SLEEP							
Low-level input voltage	V _{SLL}	—	—	—	0.7	V	—
High-level input voltage	V _{SLH}	—	2.1	—	—	V	—
Open-circuit voltage	V _{SLZ}	—	—	0	0.3	V	—
Input impedance	Z _{SL}	—	70	100	130	kΩ	—
Soft Start							
Charging current	I _{SOFT}	—	0.6	1	1.4	μA	—
Hall Bias							
VHALL voltage	V _{VHALL}	—	V _{VREG} -1	V _{VREG}	—	V	—
Output impedance	Z _{VHALL}	I _{VHALL} = 5 mA	—	—	100	Ω	—

ELECTRICAL CHARACTERISTICS (continued)

V_{CC}=12V,

Note) T_a = 25°C±2°C unless otherwise noted.

Parameter	Symbol	Condition	Limits			Unit	Note
			Min	Typ	Max		
Thermal Protection (Reference for Design)							
Protection operating temperature	TSD _{ON}	—	—	160	—	°C	—
Hysteresis width	TSD _{HYS}	—	—	25	—	°C	—
Output Block (Reference for Design)							
Output slew rate at source current	V _{TRSO}	Rising edge	—	300	—	V/μs	—
Output slew rate at source current	V _{TFSO}	Falling edge	—	300	—	V/μs	—
Output slew rate at sink current	V _{TRSI}	Rising edge	—	300	—	V/μs	—
Output slew rate at sink current	V _{TFSI}	Falling edge	—	300	—	V/μs	—
Maximum Rotating Speed							
Minimum hall cycle	T _{HMIN}	—	—	173	—	μs	—
Under Voltage Lock Out							
Protection operating voltage	V _{LVON}	—	—	4	—	V	—
Protection release voltage	V _{LVOFF}	—	—	5	—	V	—
Over Voltage Lock Out							
Protection operating voltage	V _{OVON}	—	—	27.6	—	V	—

PIN CONFIGURATION

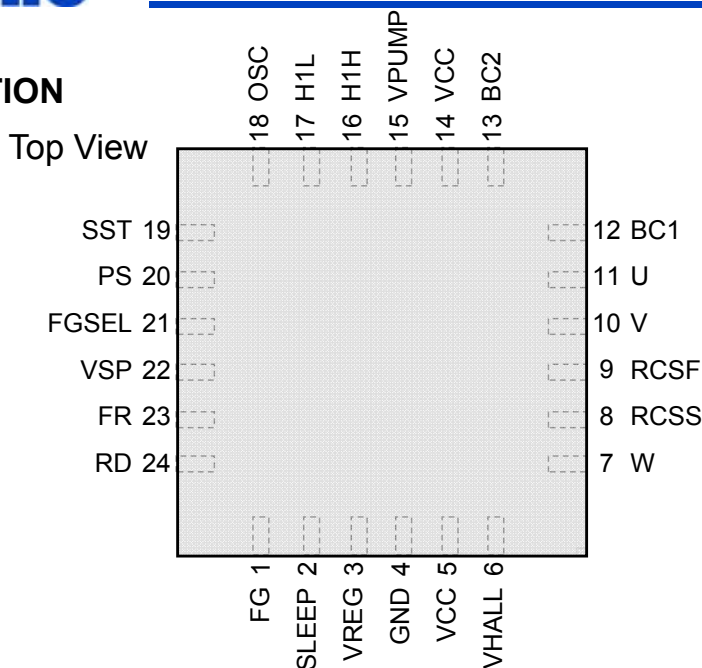

PIN FUNCTIONS

Pin No.	Pin name	Type	Description
1	FG	Output	FG pulse output. This terminal outputs a pulse period equal to the Hall element output.
2	SLEEP	Input	Sleep setting. Enter the "H" when setting sleep.
3	VREG	Output	Internal reference voltage(5V). A capacitor must be connected to GND.
4	GND	Ground	Ground
5,14	VCC	Power Supply	Supply voltage for IC and motor. A capacitor must be connected to GND.
6	VHALL	Output	Supply voltage for hall element. Connected to the input terminal of the Hall element.
7	W	Output	W-phase output. Connected to the W-terminal of the motor coil.
8	RCSS	Input	Sense for motor current detector. If noise occurs, configure the low-pass filter.
9	RCSF	Output	Force for motor current detector. A resistor must be connected to GND.
10	V	Output	V-phase output. Connected to the V-terminal of the motor coil.
11	U	Output	U-phase output. Connected to the U-terminal of the motor coil.
12	BC1	Output	Pulse output for charge pump. A capacitor must be connected between BC1 and BC2.
13	BC2	Input	Pulse input for charge pump. A capacitor must be connected between BC1 and BC2.
15	VPUMP	Output	Charge pump circuit output. A capacitor must be connected to VCC or GND.
16	H1H	Input	Hall amplifier input (+). Connected to the output terminal of the Hall element.
17	H1L	Input	Hall amplifier input (-). Connected to the output terminal of the Hall element.
18	OSC	Input	Setting oscillation frequency of triangular wave. PWM frequency can be changed by the capacitor connected to GND.
19	SST	Input	Soft start setting. Soft-start time can be changed with a capacitor connected to GND.
20	PS	Input	Drive phase shift control. Three level input voltage can be switched.(0/10/25deg)
21	FGSEL	Input	FG pulse count select. Three level input voltage can be switched.(1/1,1/2,1/3)
22	VSP	Input	Voltage input for setting rotating speed. Variable range 0.5-4.5V input DC, 4.5V or more will be full speed.
23	FR	Input	Rotation direction select (Forward/Reverse). At "L" input, turn on electricity in order of U→V→W. At "H" input, turn on electricity in order of U→W→V.
24	RD	Output	Over load protection. At the time of the motor restriction, output "L".

FUNCTIONAL BLOCK DIAGRAM

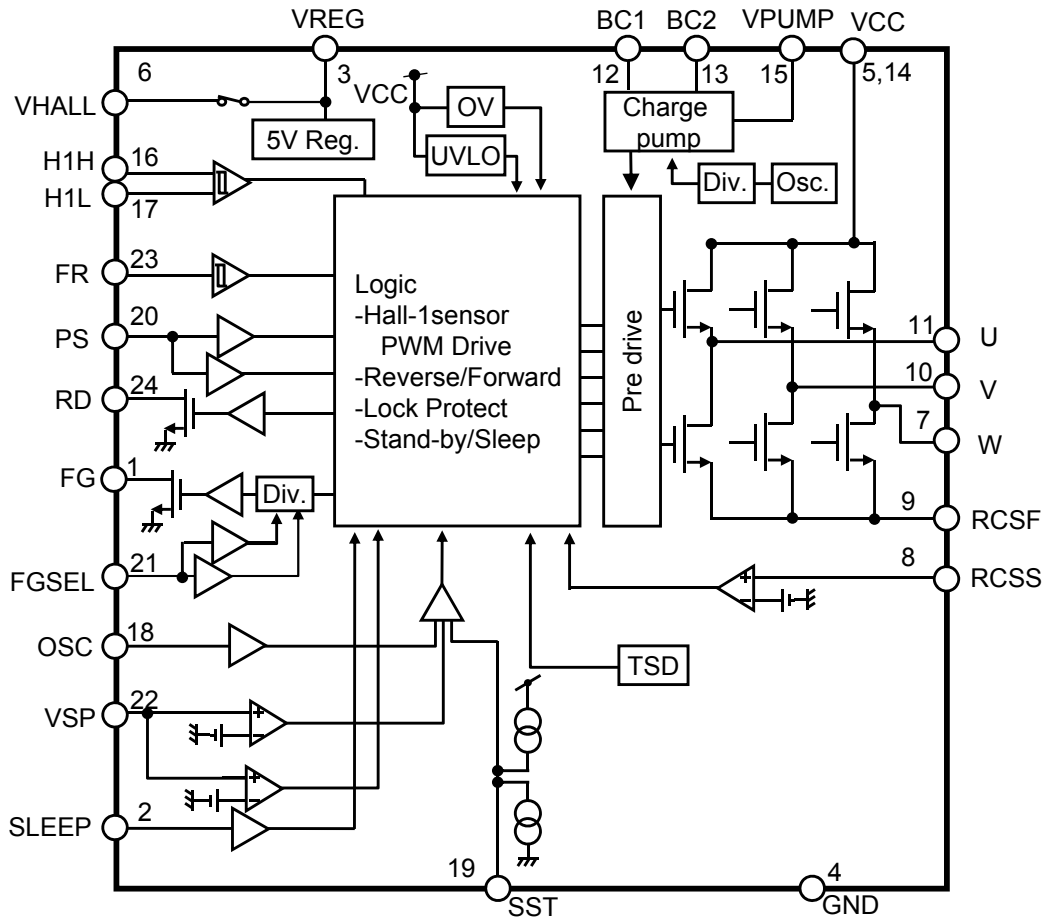

Notes) This block diagram is for explaining functions. The part of the block diagram may be omitted, or it may be simplified.

OPERATION

Note) the characteristics listed below are reference values derived from design of the IC and are not guaranteed.

1. Example of Duty variations that depend on VSP Voltage

The value used in this page is applied when you use the reference capacity of OSC.

OHall Voltage Difference
 $H_U = H_{1H} - H_{1L}$

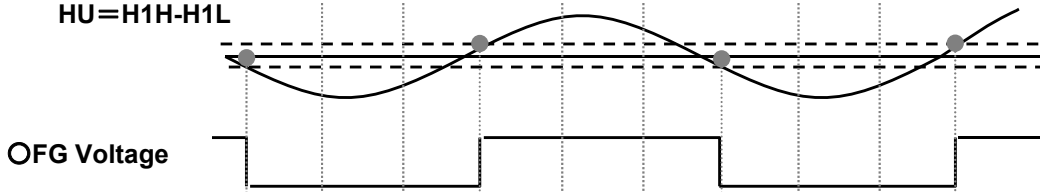

OAverage Output Voltage

AREA①
 • $VSP \cong 0.55 \sim 4.0V$
 Duty depend on linear to VSP

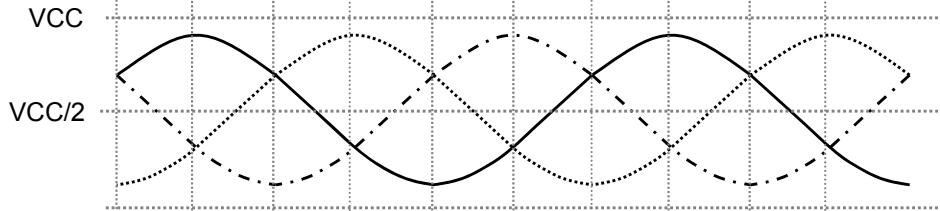

AREA②
 • $VSP \cong 4.0V \sim 4.5V$
 Duty depend on non-linear to VSP, because of distortion.
 • $VSP > 4.5V$
 Duty constant regardless of VSP

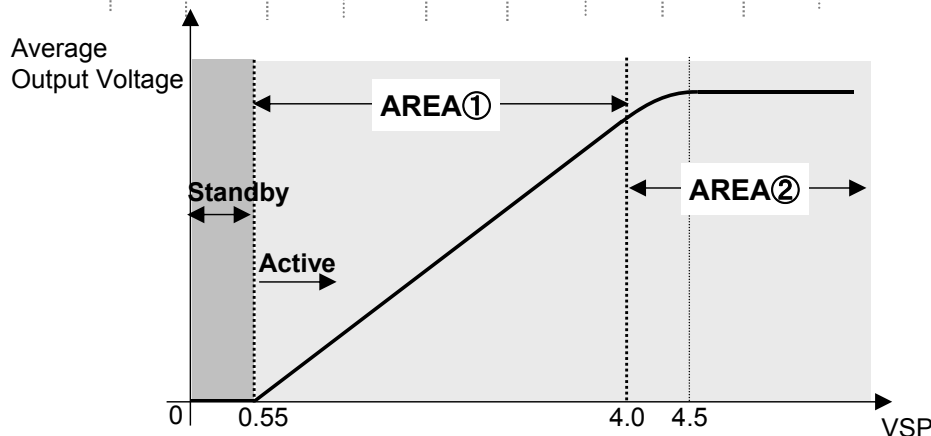
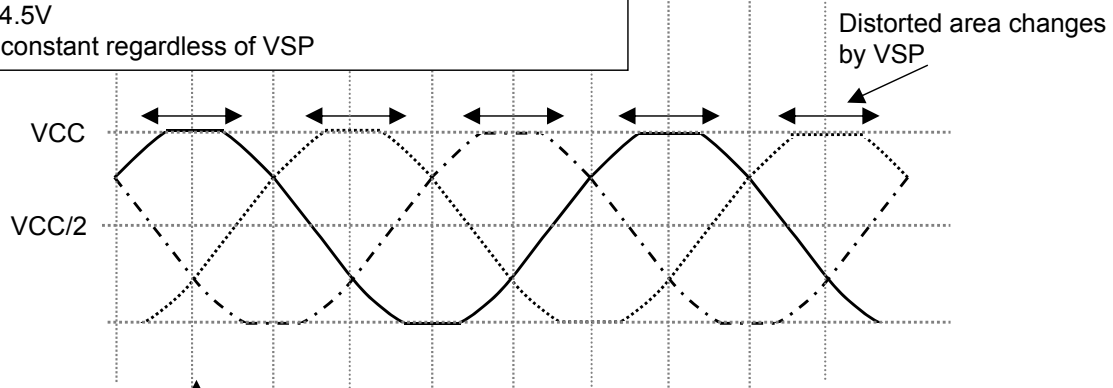

OPERATION (Continued)

Note) the characteristics listed below are reference values derived from design of the IC and are not guaranteed.

2.Soft Start Function and PWM Specification

Soft start function is enabled by setting startup condition in mode transition. In addition, SST pin voltage is converged to 0.5 V by discharging the external capacitor connected with SST pin at 2 mA, 10 ms prior to startup mode. Then, SST pin voltage is increased up to VPS voltage (< 4.5V), by charging at 1 μ A. PWM waveform is also determined by comparison of triangular wave and VSP pin voltage.

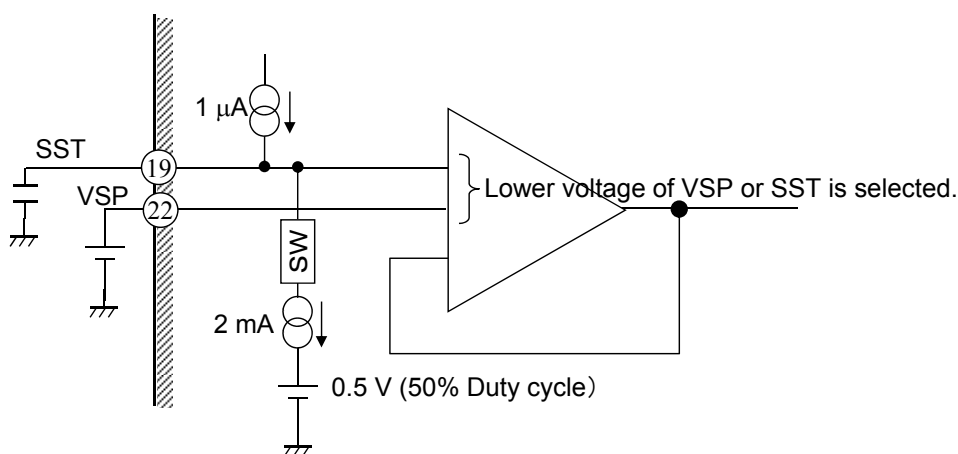

Timing charts for SST, PWM and VSP is shown below.

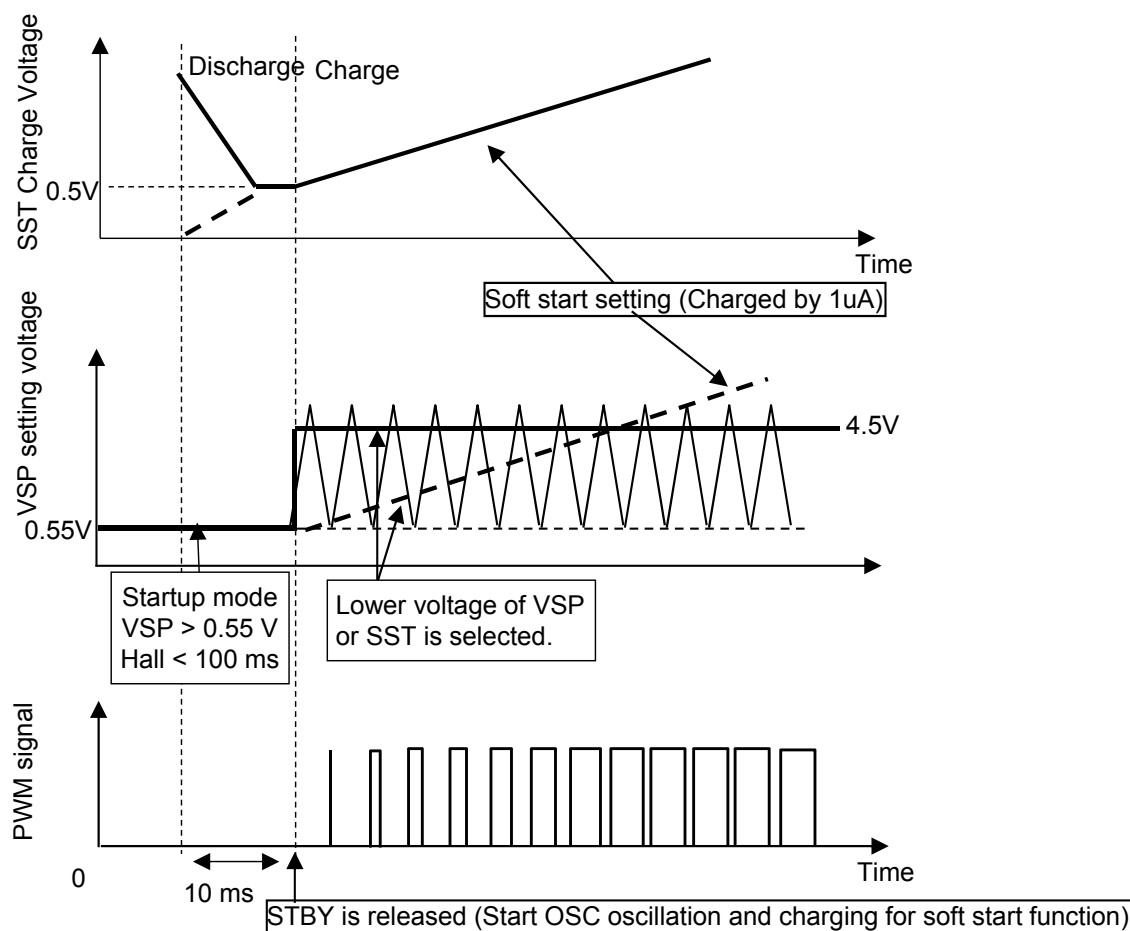

OPERATION (Continued)

Note) the characteristics listed below are reference values derived from design of the IC and are not guaranteed.

3. Hall Input Specification

3.1. The System of Detecting The Motor Position

The motor position is detected by Hall hysteresis comparator. If the amplitude of sine wave is small, phase delay of comparator output is remarkable. So, make the amplitude of sine wave larger. More than 200 mV of amplitude is recommended. When chattering occurs to Hall element, insert a capacitor between H1H (pin 16) and H1L (pin 17).

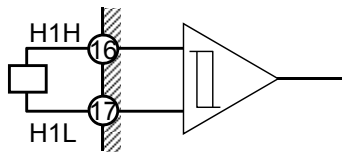

Schematic drawing for characteristics below

J-1 hysteresis level: 7.5 mV H→L

J-2 hysteresis level: 7.5 mV L→H

J-3 hysteresis width: 15.0 mV

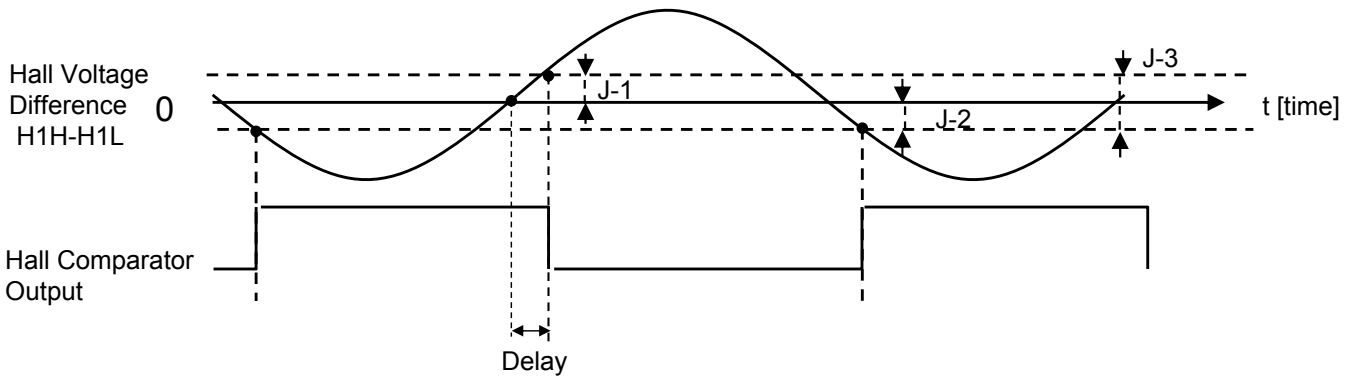

VHALL, bias source for Hall element, is connected to VREG inside the IC. When VSP voltage is 0.55V or more, IC enters Active mode from Standby mode and VHALL starts supply of voltage to Hall element. When a cycle of Hall signal decrease to 1.8Hz or less in Standby mode (VSP voltage is 0.55V or less), VHALL stops supply of voltage to Hall element. When adjusting an amplitude of Hall signal, pay attention to exceeding the rating current of VREG and heat generation. One example for prevention is shown below.

Normal use

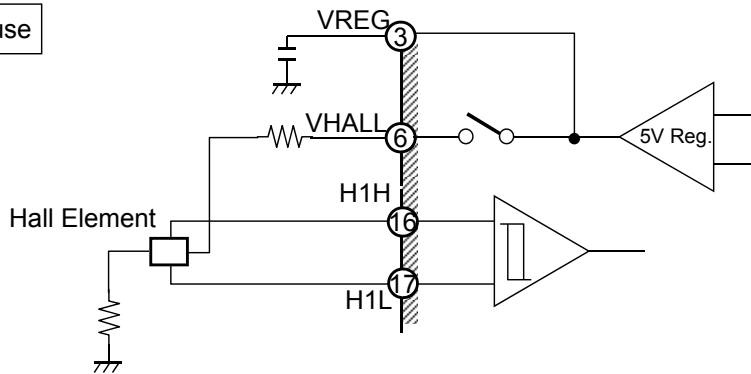

Example for prevention

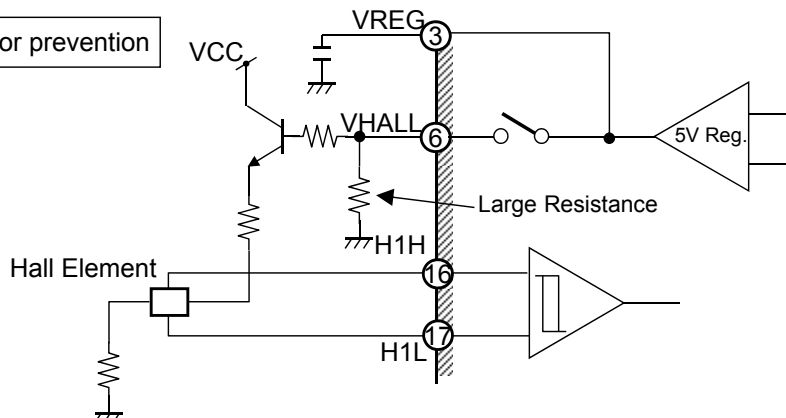

OPERATION (Continued)

Note) the characteristics listed below are reference values derived from design of the IC and are not guaranteed.

3. Hall Input Specification (Continued)

3.2. The Relation among Hall, FR (Forward/Reverse) and Average Output Voltage

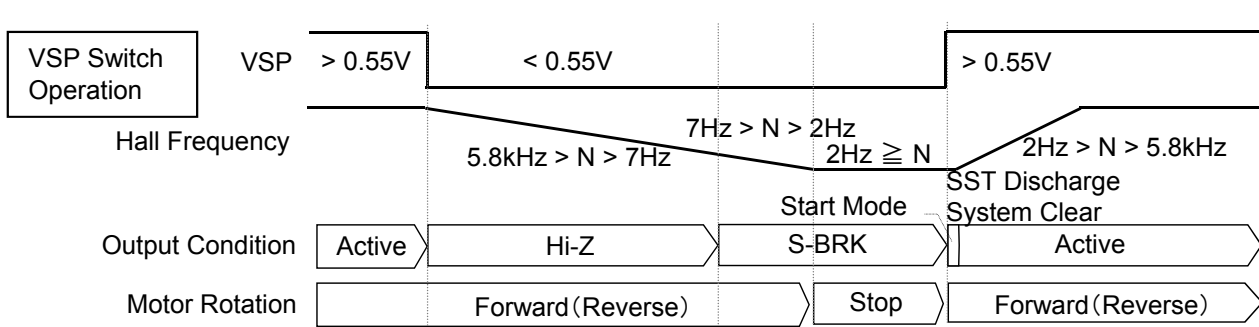
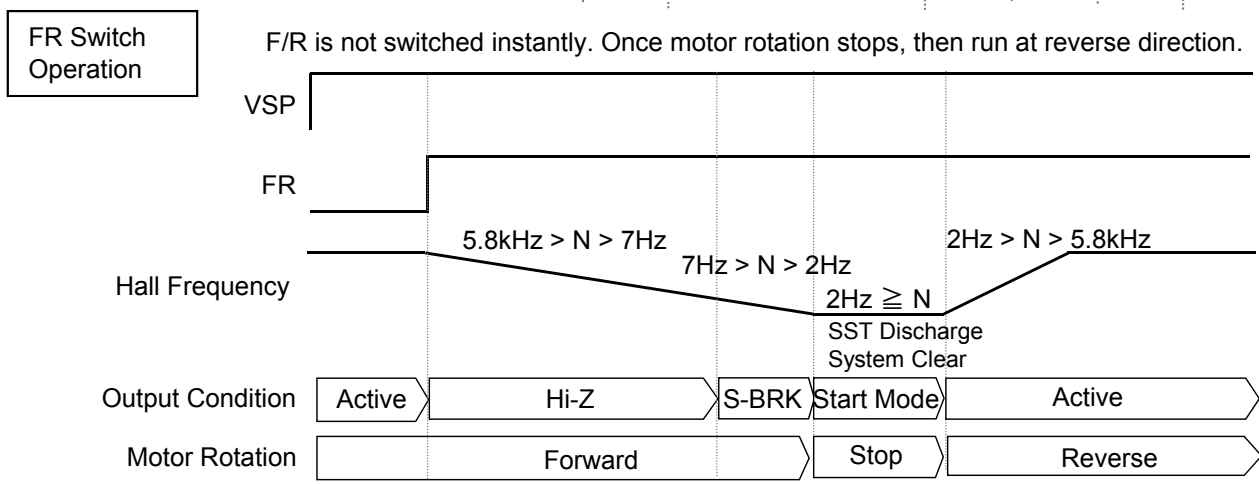
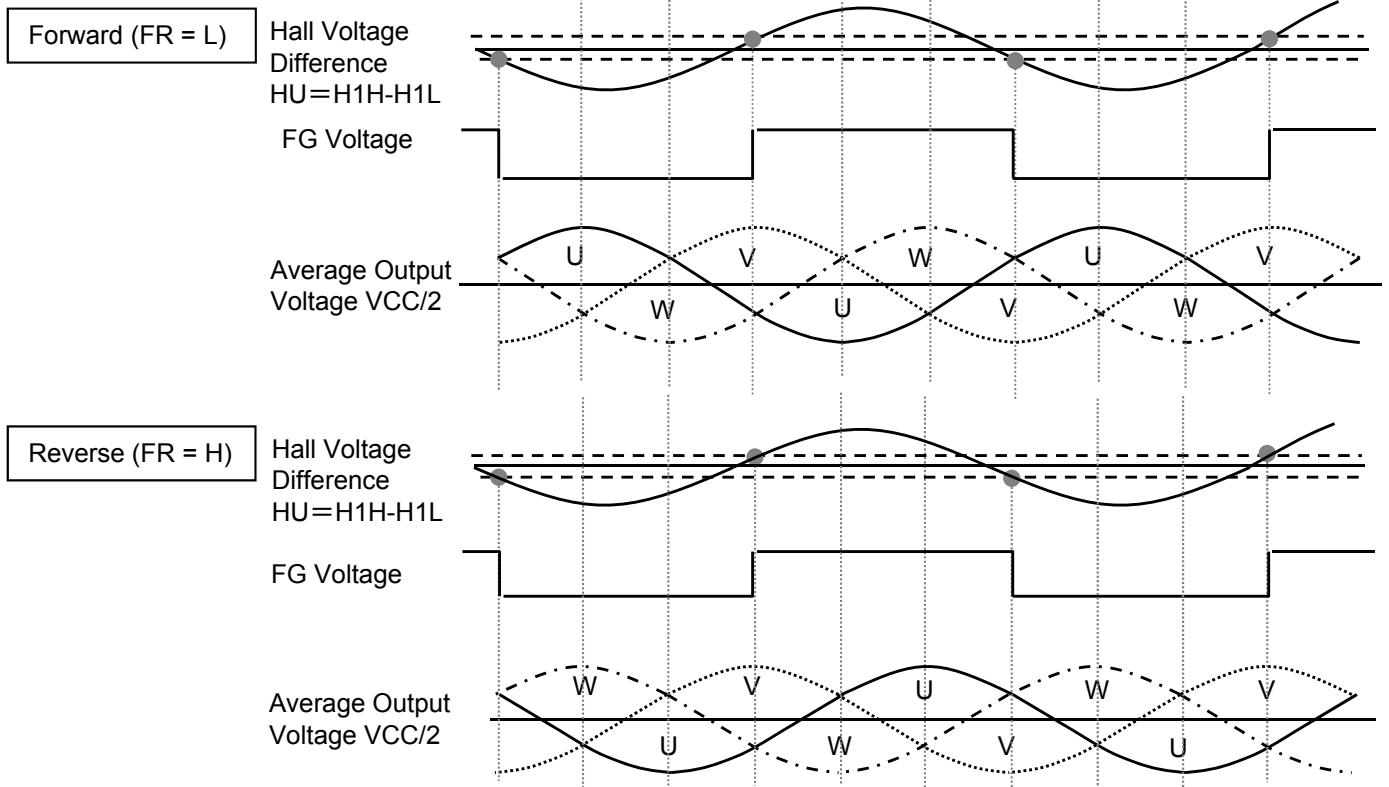

OPERATION (Continued)

Note) the characteristics listed below are reference values derived from design of the IC and are not guaranteed.

3. Hall Input Specification (Continued)

3.3. The Relation between Hall Voltage and FGSEL

1-cycle FG signal, which is equivalent to 1-cycle/2-cycle/3-cycle of Hall sine wave (selected by FGSEL), is output.

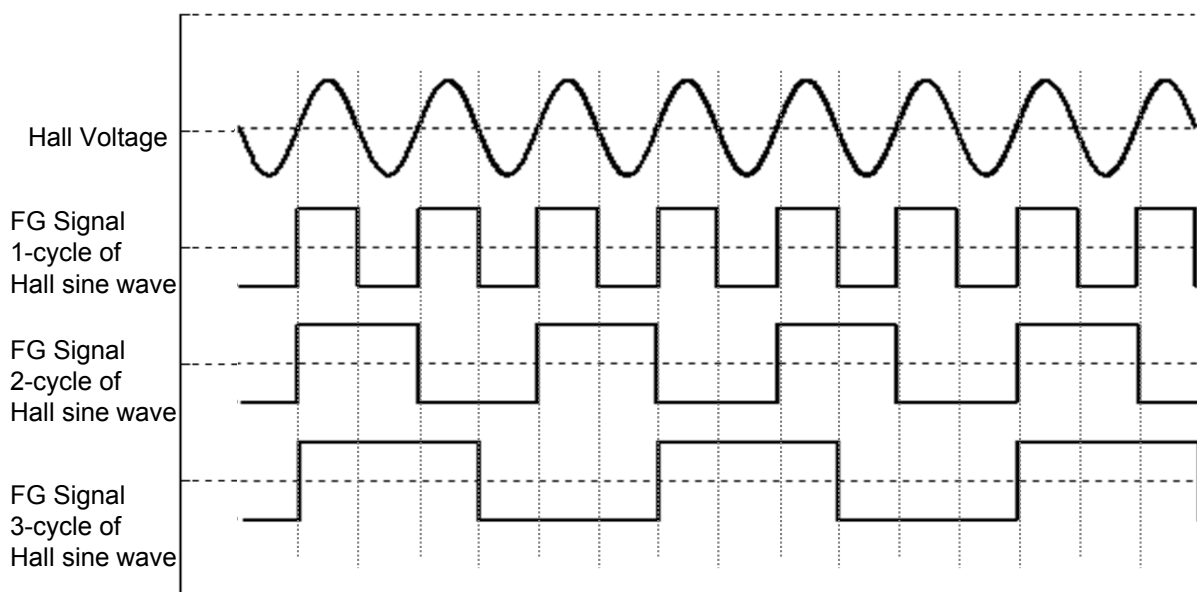

3.4. Drive Phase Shift Control

The drive phase shift control have Three values (0 degree /10 degree /25 degree). The shift direction of angle is the same as rotation direction. The example for U-phase output voltage at forward rotation is shown below.

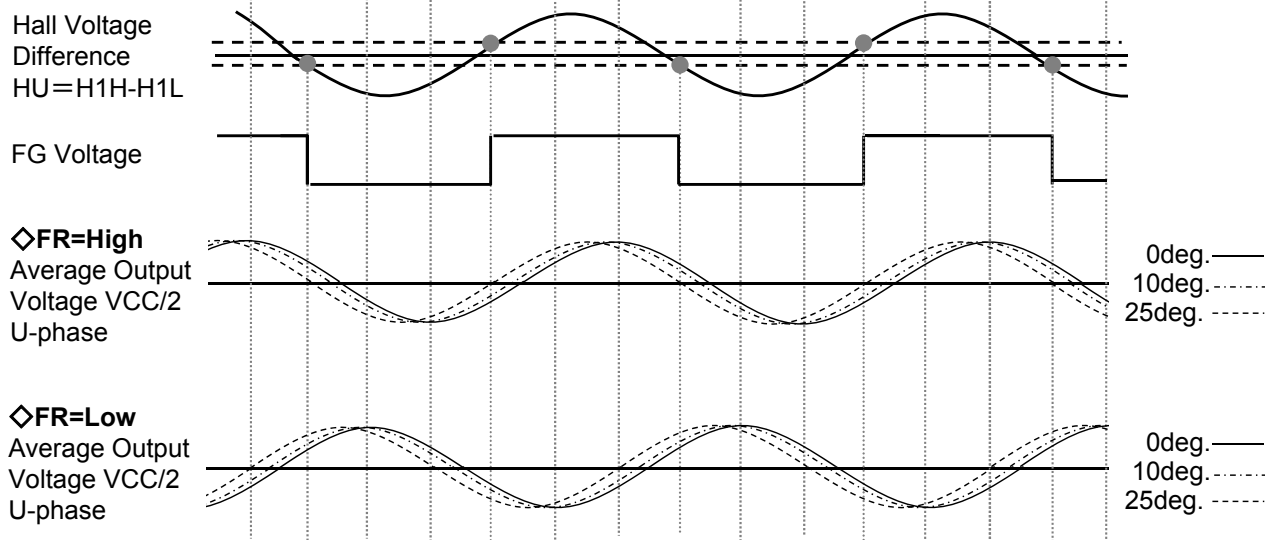

Pin No.	Pin Name	Description	Pin Voltage		
			Low	Middle	High
20	PS	Drive phase shift Control	0 deg.	10 deg.	25 deg.

OPERATION (Continued)

3. Hall Input Specification (Continued)

3.4. Mounting HALL location

The following is the mounting location of the Hall element, a timing chart of the average voltage of the PWM signal and the output of the Hall signal voltage difference(H1H-H1L).

The phase difference between the voltage and the actual driving current Hall signal, there is a delay. Please consider adjust or by switching the PS terminal(0/10/25deg), the point of attachment of the Hall element in fine-tuning, the optimum efficiency.

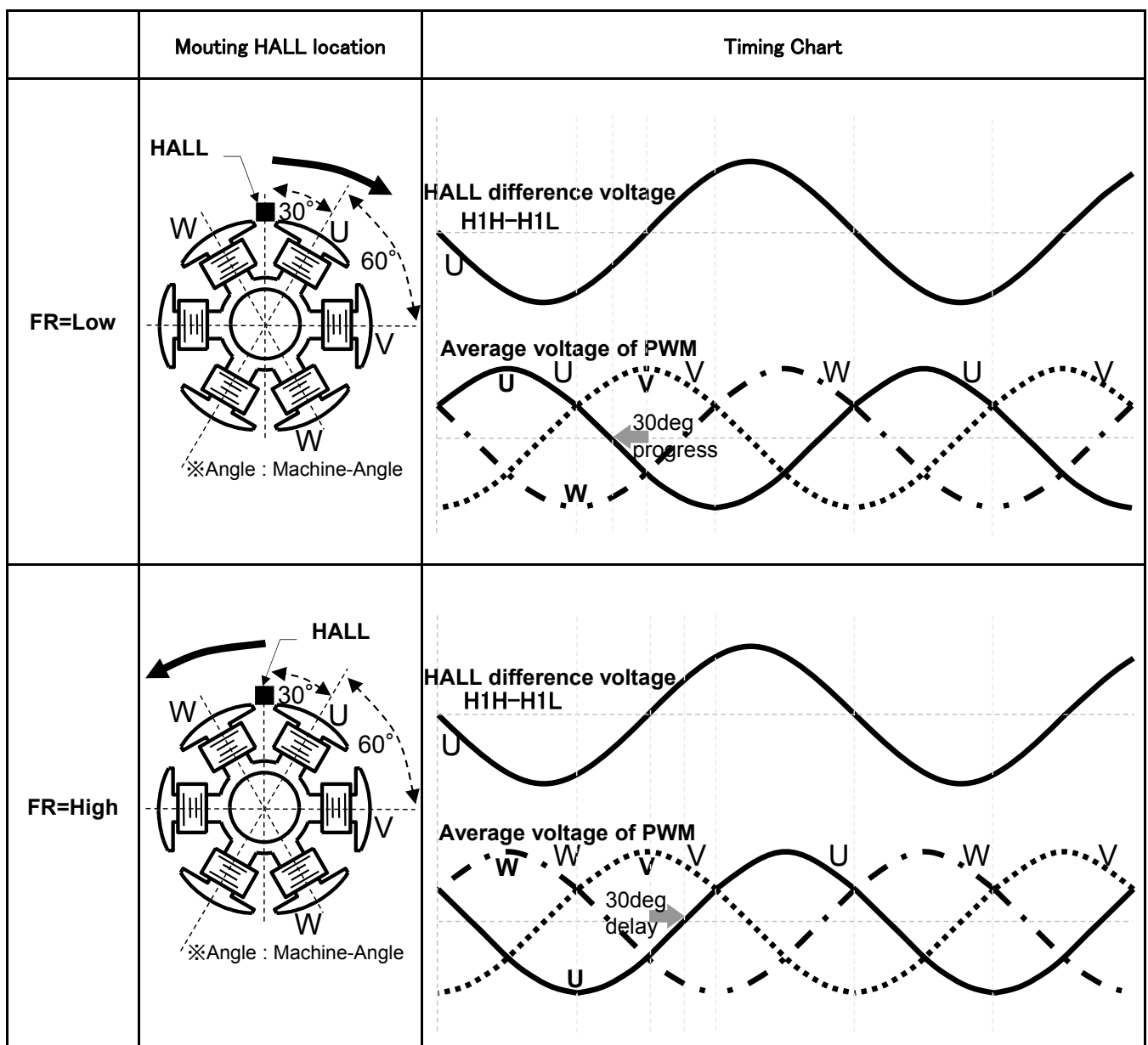

OPERATION (Continued)

Note) the characteristics listed below are reference values derived from design of the IC and are not guaranteed.

4. Oscillation Frequency of Triangular Wave

The formula to calculate triangular wave for OSC output is shown below. PWM waveform is generated by comparison of this Triangular wave and Hall sine wave. Therefore, the frequency of triangular wave corresponds to that of PWM.

$$\text{The frequency of triangular wave } f_{\text{OSC}} = \frac{A}{2 \times C_{\text{OSC}} \times (V_{\text{OSCH}} - V_{\text{OSCL}})}$$

V_{OSCH} : Maximum voltage of triangular wave (typical 2.8 V)
 V_{OSCL} : Minimum voltage of triangular wave (typical 1.2 V)
 A : 100 μA (typical)

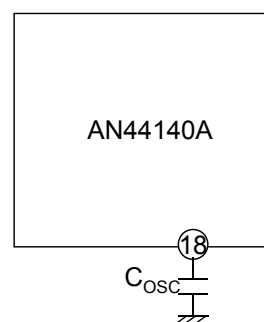

5. Motor Current Setting

I_{PEAK} : Peak of motor current value is determined by current detection resistor (RCSF) and reference voltage (0.25 V). If noise is generated, configure LPF to RCSS pin.

$$I_{\text{PEAK}} = 0.250\text{V} \times \frac{1}{\text{RCSF}}$$

Example) Refer to the formula above, in the case $I_{\text{PEAK}} = 1.00 \text{ A}$, use a 0.250 Ω resistor as RCSF.

$$\text{RCSF} = 0.250(\text{V}) \times \frac{1}{1.00(\text{A})} = 0.250(\Omega)$$

6. Reduction in Power Consumption

There are 2 modes for consumption power reduction.

	Enter the Mode	Motor Output	VREG Voltage	Exit the Mode
STBY SLEEP pin: L	No signal for Hall input, $t > 565 \text{ ms}$, $\text{VSP} < 0.55 \text{ V}$	S-BRK	ON	UVLO Restart $\text{VSP} > 0.55 \text{ V}$
SLEEP SLEEP pin: H	Sleep pin: L \Rightarrow H (Immediately)	All phases OFF	OFF	UVLO Restart Sleep pin: H \Rightarrow L

When SLEEP pin is changed "L" to "H" while motor is running at high speed, motor output of all phases turns OFF. However, motor output might cause malfunction because VREG is OFF. Conduct enough evaluation if SLEEP pin is switched while motor is running at high speed.

OPERATION (Continued)

Note) the characteristics listed below are reference values derived from design of the IC and are not guaranteed.

7. Protection Functions

7.1. Motor Lock Protection

When no signal for Hall signal input is continued for 0.5 s or more, motor output turns OFF (short-brake) and Motor Lock Protection starts working (RD = L), and recovers automatically after 5 s elapses. Motor Lock Protection is released immediately by Hall signal input 5cycles or more signal of 2Hz or more, Sleep input (Sleep → Active) or re-turning on VCC.

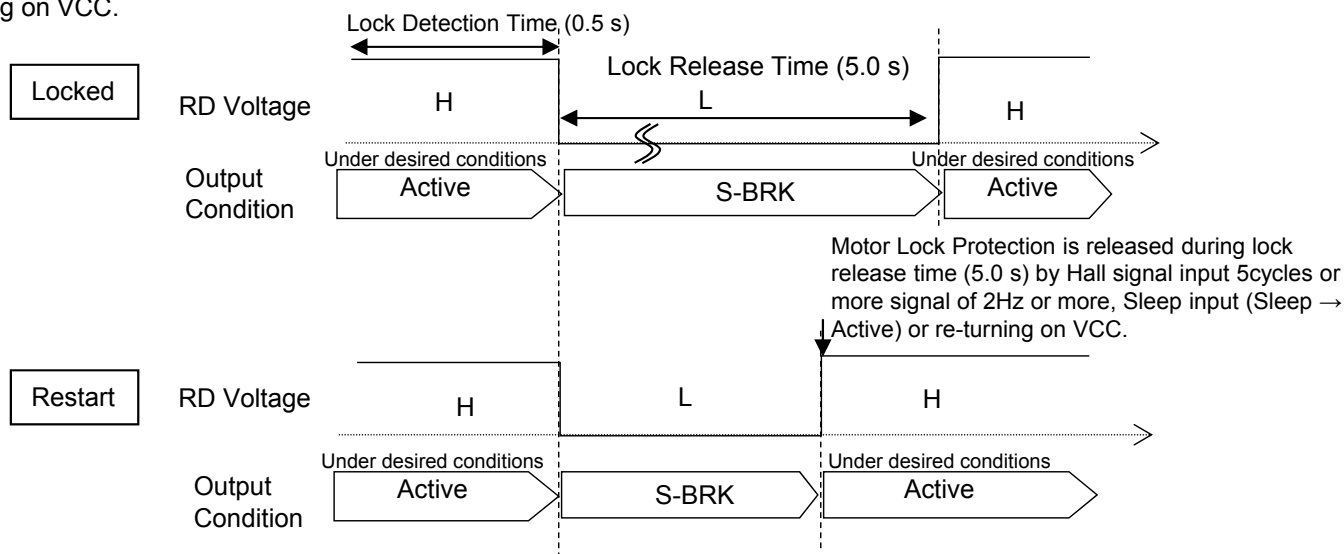

7.2. Under Voltage Lock Out (UVLO)

When VCC voltage drops to 4 V or less, UVLO starts working and motor output turns OFF. When VCC voltage increases to 5 V or more, UVLO is released.

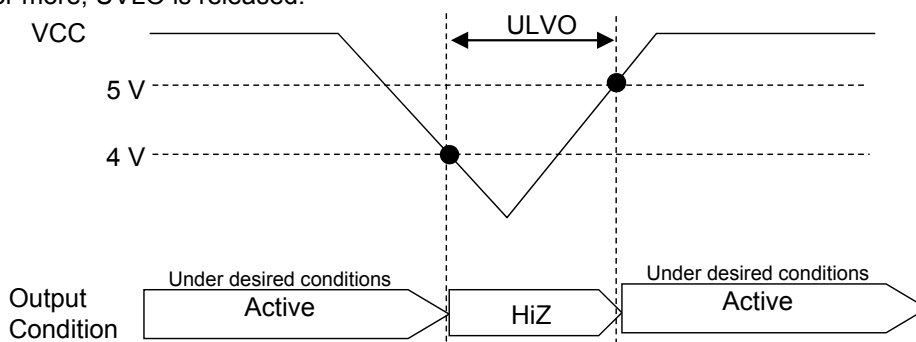

7.3. Over Voltage Lock Out (OVLO)

When VCC voltage exceeds 27.6 V, OVLO starts working and motor output enters short-brake mode. When VCC voltage decreases below 27.6 V, OVLO is released.

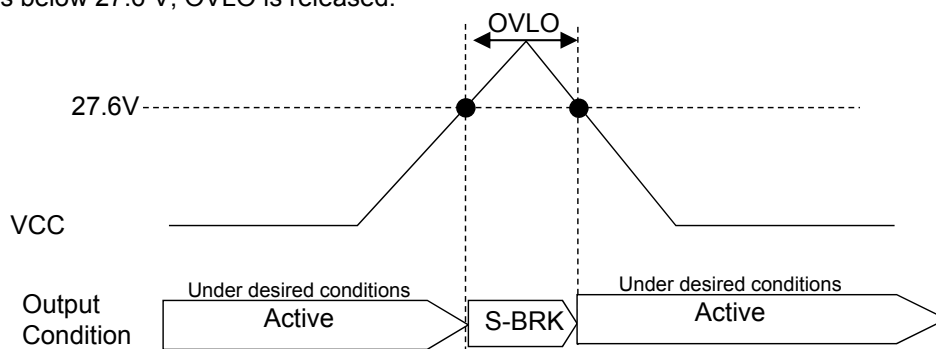

OPERATION (Continued)

Note) the characteristics listed below are reference values derived from design of the IC and are not guaranteed.

7. Protection Functions (Continued)

7.4. Over Current Protection (OCP)

When RCSS voltage increases to 0.25 V or more, OCP starts working and motor output enters short-brake mode.
When RCSS voltage decreases to 0.25 V or less, OCP is released.

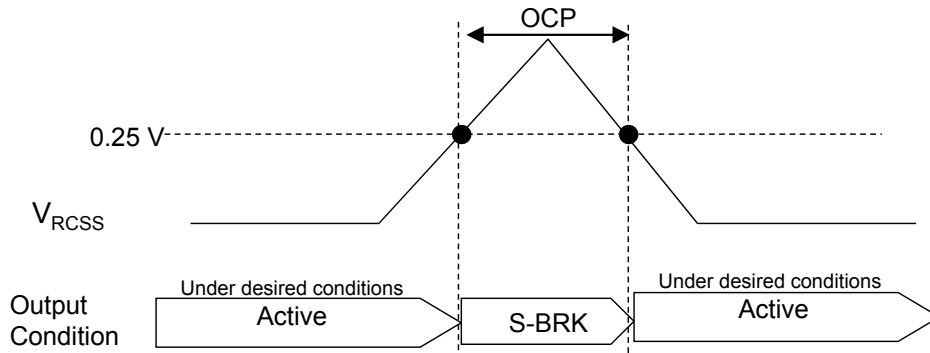

7.5. Thermal Shut Down (TSD)

When IC junction temperature exceeds 160°C, TSD starts working and motor output turns OFF. When IC junction temperature decreases below 135°C, TSD is released.

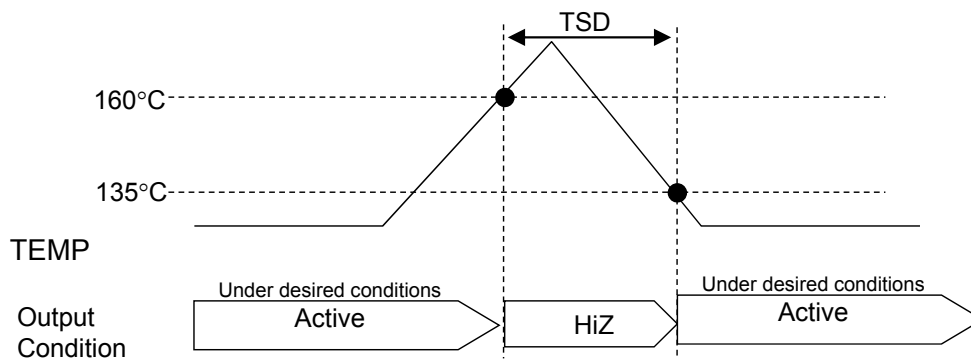

OPERATION (Continued)

Note) the characteristics listed below are reference values derived from design of the IC and are not guaranteed.

8.Control mode Table

Pin No.	Pin Name	Description	Voltage		Remarks
			Low	High	
2	SLEEP	Sleep mode select	Normal	Sleep	SLEEP = "H": Sleep mode (Motor output: OFF, VREG output: OFF) SLEEP = "L": Normal mode Note) For set range of SLEEP control voltage, refer to "SLEEP" of the Electrical Characteristics on page 5.
23	FR	Rotation direction select (Forward/Reverse)	Forward	Reverse	Arbitrary direction is denoted as "Forward", and reverse direction is denoted as "Reverse". Note) For set range of FR control voltage, refer to "FR" of the Electrical Characteristics on page 5.

Pin No.	Pin Name	Description	Voltage			Remarks
			Low	Middle	High	
20	PS	Drive phase shift control [degree]	0	10	25	Note) For detention range of PS control voltage, refer to "PS" of the Electrical Characteristics on page 5.
21	FGSEL	FG pulse count select [ratio of hall signal cycle]	1/3	1/2	1	FG pulse output which is equivalent to arbitrary magnification of hall signal cycle Note) For set range of FGSEL control voltage, refer to "FGSEL" of the Electrical Characteristics on page 5.

PACKAGE INFORMATION (Reference Data)

Package Code:HQFN024-A-0404

unit:mm

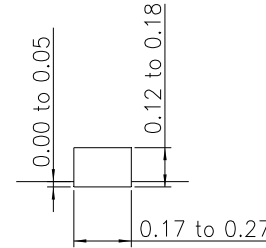
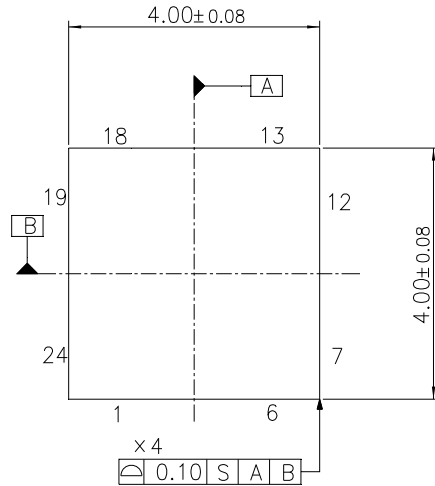

Section A (Reference value)

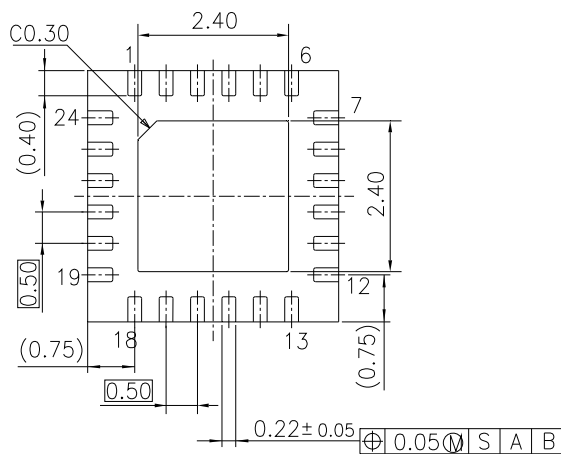
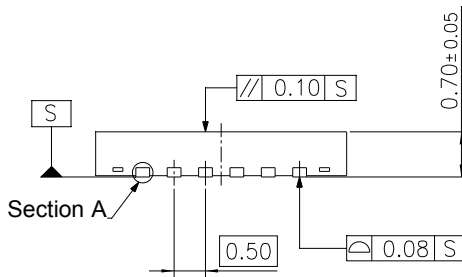

Body Material	: Br/Sb Free Epoxy Resin
Lead Material	: Cu Alloy
Lead Finish Method	: Au Plating

Power Dissipation (Technical Report)

Package Code:HQFN024-A-0404

Note) the characteristics listed below are reference values derived from design of the IC and are not guaranteed.

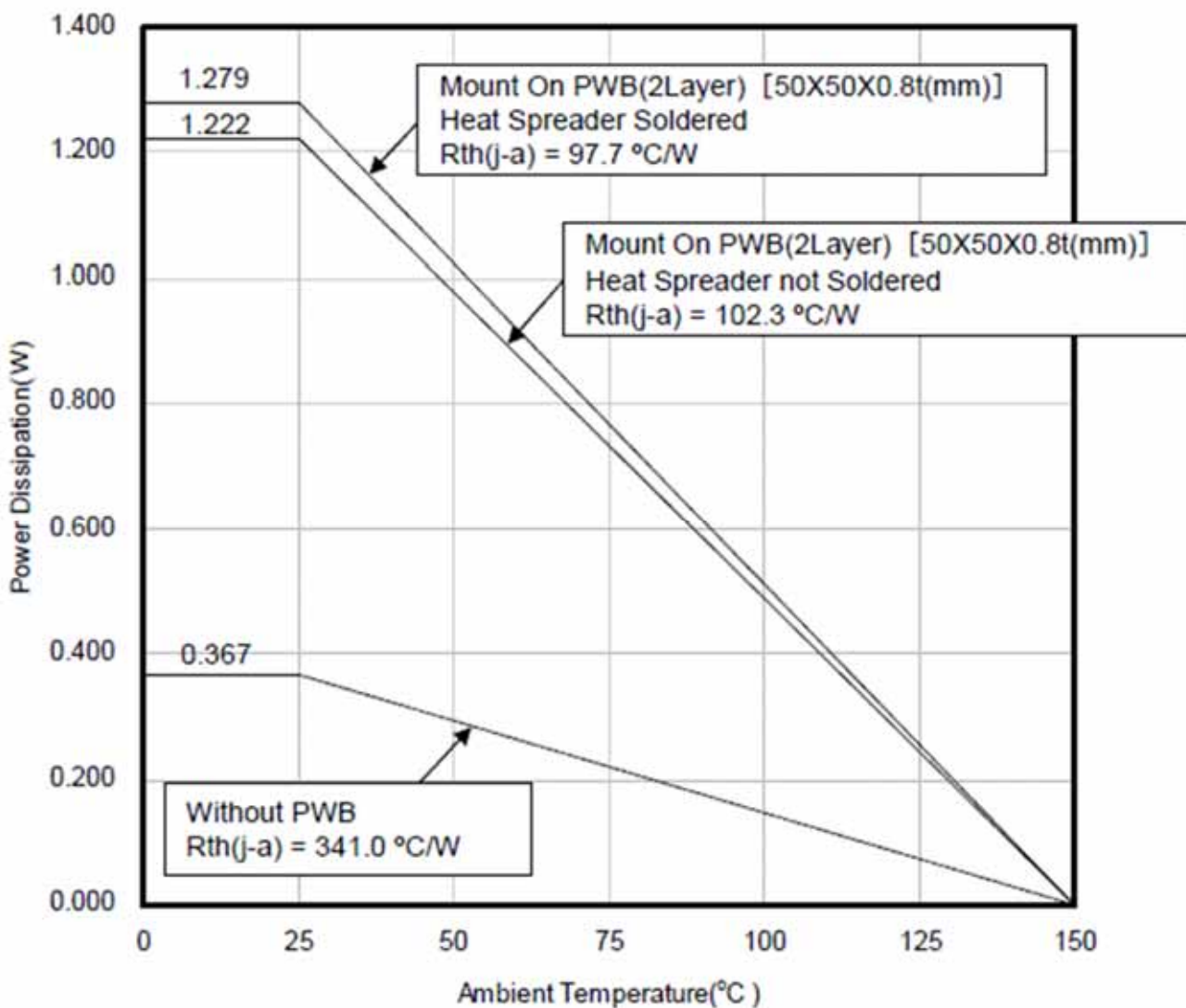

Power Dissipation (Supplementary Explanation)

Package Code:HQFN024-A-0404

Note) the characteristics listed below are reference values derived from design of the IC and are not guaranteed.

[Experiment environment]

Power Dissipation (Technical Report) is a results in the experiment environment of SEMI standard conformity. (Ambient air temperature (Ta) is 25 degrees C)

[Supplementary information of PWB to be used for measurement]

The supplement of PWB information for Power Dissipation data (Technical Report) are shown below.

Indication	Total layer	Resin Material
Glass-Epoxy	1-layer	FR-4
4-layer	4-layer	FR-4

[Notes about Power Dissipation (Thermal Resistance)]

Power Dissipation values (Thermal Resistance) depend on the conditions of the surroundings, such as specification of PWB and a mounting condition, and a ambient temperature. (Power Dissipation (Thermal Resistance) is not a fixed value.)

The Power Dissipation value (Technical Report) is the experiment result in specific conditions (evaluation environment of SEMI standard conformity), and keep in mind that Power Dissipation values (Thermal resistance) depend on circumference conditions and also change.

[Definition of each temperature and thermal resistance]

- Ta : Ambient air temperature
 ※The temperature of the air defined at the position where the convection, radiation, etc. don't affect the temperature value, and it's separated from the heating elements.
- Tc : It's the temperature near the center of a package surface. The package surface is defined at the opposite side the PWB.
- Tj : Semiconductor element surface temperature (Junction temperature).
- Rth(j-c) : The thermal resistance (difference of temperature of per 1Watts) between a semiconductor element junction part and the package surface.
- Rth(c-a) : The thermal resistance (difference of temperature of per 1Watts) between the package surface and the ambient air.
- Rth(j-a) : The thermal resistance (difference of temperature of per 1Watts) between a semiconductor element junction part and the ambient air.

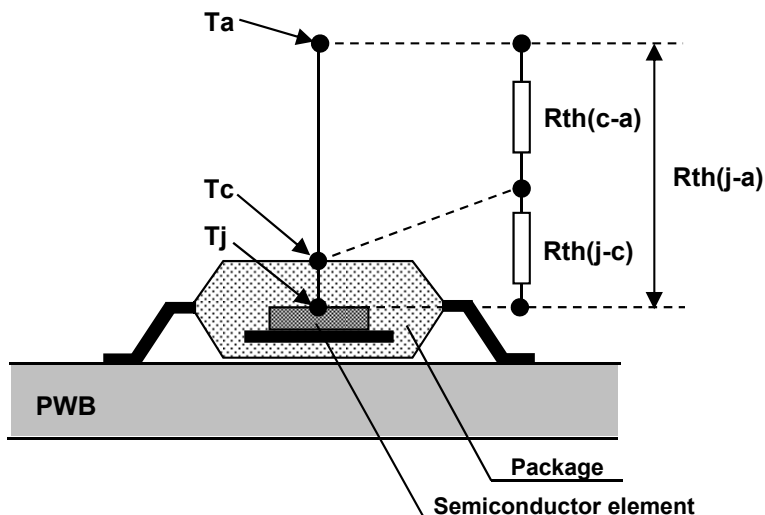

Fig . Definition image

[Definition formula]

$$Tj = \{Rth(j-c) + Rth(c-a)\} \times P + Ta$$

$$= Rth(j-a) \times P + Ta$$

$$Rth(j-c) = \frac{Tj - Tc}{P} \text{ (}^\circ\text{C/W)}$$

$$Rth(c-a) = \frac{Tc - Ta}{P} \text{ (}^\circ\text{C/W)}$$

$$Rth(j-a) = \frac{Tj - Ta}{P} \text{ (}^\circ\text{C/W)}$$

P:power(W)

■ **IMPORTANT NOTICE**

1. When using the LSI for new models, verify the safety including the long-term reliability for each product.
2. When the application system is designed by using this LSI, please confirm the notes in this book.
Please read the notes to descriptions and the usage notes in the book.
3. This LSI is intended to be used for general electronic equipment.
Consult our sales staff in advance for information on the following applications: Special applications in which exceptional quality and reliability are required, or if the failure or malfunction of this LSI may directly jeopardize life or harm the human body.
Any applications other than the standard applications intended.
 - (1) Space appliance (such as artificial satellite, and rocket)
 - (2) Traffic control equipment (such as for automobile, airplane, train, and ship)
 - (3) Medical equipment for life support
 - (4) Submarine transponder
 - (5) Control equipment for power plant
 - (6) Disaster prevention and security device
 - (7) Weapon
 - (8) Others : Applications of which reliability equivalent to (1) to (7) is requiredOur company shall not be held responsible for any damage incurred as a result of or in connection with the LSI being used for any special application, unless our company agrees to the use of such special application.
4. This LSI is neither designed nor intended for use in automotive applications or environments unless the specific product is designated by our company as compliant with the ISO/TS 16949 requirements.
Our company shall not be held responsible for any damage incurred by customers or any third party as a result of or in connection with the LSI being used in automotive application, unless our company agrees to such application in this book.
5. Please use this product in compliance with all applicable laws and regulations that regulate the inclusion or use of controlled substances, including without limitation, the EU RoHS Directive. Our company shall not be held responsible for any damage incurred as a result of our LSI being used by our customers, not complying with the applicable laws and regulations.
6. Pay attention to the direction of LSI. When mounting it in the wrong direction onto the PCB (printed-circuit-board), it might emit smoke or ignite.
7. Pay attention in the PCB (printed-circuit-board) pattern layout in order to prevent damage due to short circuit between pins. In addition, refer to the Pin Description for the pin configuration.
8. Perform a visual inspection on the PCB before applying power, otherwise damage might happen due to problems such as a solder-bridge between the pins of the semiconductor device. Also, perform a full technical verification on the assembly quality, because the same damage possibly can happen due to conductive substances, such as solder ball, that adhere to the LSI during transportation.
9. Take notice in the use of this product that it might be damaged or occasionally emit smoke when an abnormal state occurs such as output pin-VCC short (Power supply fault), output pin-GND short (Ground fault), or output-to-output-pin short (load short). Safety measures such as an installation of fuses are recommended because the extent of the above-mentioned damage and smoke emission will depend on the current capability of the power supply..
10. The protection circuit is for maintaining safety against abnormal operation. Therefore, the protection circuit should not work during normal operation.
Especially for the thermal protection circuit, if the area of safe operation or the absolute maximum rating is momentarily exceeded due to output pin to VCC short (Power supply fault), or output pin to GND short (Ground fault), the LSI might be damaged before the thermal protection circuit could operate.
11. Unless specified in the product specifications, make sure that negative voltage or excessive voltage are not applied to the pins because the device might be damaged, which could happen due to negative voltage or excessive voltage generated during the ON and OFF timing when the inductive load of a motor coil or actuator coils of optical pick-up is being driven.
12. Verify the risks which might be caused by the malfunctions of external components.
13. Comply with the instructions for use in order to prevent breakdown and characteristics change due to external factors (ESD, EOS, thermal stress and mechanical stress) at the time of handling, mounting or at customer's process. When using products for which damp-proof packing is required, satisfy the conditions, such as shelf life and the elapsed time since first opening the packages.
14. Connect a bypass capacitor to VCC pin, close to the IC, and apply a voltage with sufficiently low impedance to it.
15. After turning on VCC, while the VCC voltage rises to the set voltage, If the VCC voltage is reduced by a motor drive, Because there are times when it does not start up normally, Conduct a technical evaluation and examination sufficiently.
16. The minimum input amplitude of hall signal comparator should be at least 100 mV [p-p] in consideration of dispersion and temperature characteristics of hall element under the working condition. To increase phase detection accuracy, it should be at least 200 mV [p-p] at Ta = 25°C.
17. Do not change the control signal to SLEEP pin (pin 2) from Low to High while motor is running at high speed. The IC can be damaged due to the effect of induced voltage and conduction angle. Conduct a technical evaluation and examination sufficiently.

■ **IMPORTANT NOTICE (Continued)**

18. In case the motor running speed changes from high to low rapidly, supply voltage can be increased due to the flow back of motor current. Conduct a technical evaluation and examination sufficiently.
19. VSP-terminal changes to 0.55V or less (Standby voltage) during the lock protection operation, and if the protection is continuing, lock protection will be canceled automatically after 5 seconds from the time it was set VSP-terminal to 0.55V or more (Active voltage).
20. In the 1-HALL-sensor system motor driver adopted in this IC, Energization pattern of a cycle is generated based on previous 1-cycle of a HALL input signal. Therefore, when the acceleration of a motor is very large, a motor may be unable to accelerate normally because a big difference of cycle arises between generated energization pattern and a motor rotation. Conduct a technical evaluation and examination sufficiently about the sudden acceleration from low rotation in the case of use of a motor with very large acceleration. When the above acceleration problems arise, input the sleep input again (Sleep→Active) or reset rotation speed after the motor stops (please set the VSP voltage to 0.55V or less again), and the motor will be in normal acceleration for this IC enters the start-up mode.
21. When designing PCB pattern, place a resistor for current detection (RCS) close to the IC. Otherwise, the setting value for over current protection may fluctuate due to the impedance of wiring pattern between RCSF pin and RCS.
22. FG pin (pin 1) and RD pin (pin 24) are open-drain outputs. Connect a pull-up resistor to the designated power supplies and use this IC within the allowable voltage and current ranges.
23. Dip soldering is not recommended.
24. Design the heat radiation with sufficient margin so that Power dissipation must not be exceeded base on the conditions of power supply voltage, load and ambient temperature.
 (It is recommended to design to set connective parts to 70% to 80% of maximum rating)
25. This IC has five protecting functions. Pay attention to the descriptions below.

Function	Operate/Release	Conditions	Remarks
UVLO	<ul style="list-style-type: none"> • Operate: VCC ≤ 4 V • Release: VCC ≥ 5 V 	All phases: OFF	Since all phases are OFF while protecting function works, reverse current can be generated due to the repetition of on-off switching of protecting function during motor rotation. Pay attention to the voltage rise.
OVLO	<ul style="list-style-type: none"> • Operate/Release: VCC = 27.6V(typ.) 	Upper-phase: OFF Lower-phase: ON	Large current can be generated due to a short break during motor rotation. Conduct a technical verification to prevent damages sufficiently.
Over Current Protection	<ul style="list-style-type: none"> • Operate: RCSS voltage ≥ 0.25 V (typ.) • Release: RCSS voltage ≤ 0.25 V (typ.) 	Upper-phase: OFF Lower-phase: ON	RCSS and RCSF are sense and force of current detection resistor respectively. Concerning level of detection, false detection can occur due to the effect of PCB layout or noise. Therefore, configure LPF between RCSS and RCSF in order to prevent false detection. Also, when specifying the resistance value of RCSF, take the followings into consideration: level of detection, dispersion of resistance value of RCS, temperature, ratings, etc.
Motor Lock Protection	<ul style="list-style-type: none"> • Operate: Hall signal input cycle ≥ 0.5 s • Release: Automatic reset (after 5 s, VSP > 0.5 V) Immediate release conditions: Any Hall signal input (5cycles or more signal of 2Hz or more), Sleep input (Sleep → Active), and returning on VCC. 	Upper-phase: OFF Lower-phase: ON	Breaking current is generated due to the short break during motor rotation. Conduct a technical verification to prevent damages sufficiently.
Thermal Protection	<ul style="list-style-type: none"> • Operate: IC junction temperature >160°C • Release: IC junction temperature < 135°C 	All phases: OFF	Since all phases are OFF while protecting function works, reverse current can be generated due to the repetition of on-off switching of protecting function during motor rotation. Pay attention to the voltage rise.

Request for your special attention and precautions in using the technical information and semiconductors described in this book

- (1) If any of the products or technical information described in this book is to be exported or provided to non-residents, the laws and regulations of the exporting country, especially, those with regard to security export control, must be observed.
- (2) The technical information described in this book is intended only to show the main characteristics and application circuit examples of the products. No license is granted in and to any intellectual property right or other right owned by Panasonic Corporation or any other company. Therefore, no responsibility is assumed by our company as to the infringement upon any such right owned by any other company which may arise as a result of the use of technical information described in this book.
- (3) The products described in this book are intended to be used for general applications (such as office equipment, communications equipment, measuring instruments and household appliances), or for specific applications as expressly stated in this book.
Please consult with our sales staff in advance for information on the following applications, moreover please exchange documents separately on terms of use etc.: Special applications (such as for in-vehicle equipment, airplanes, aerospace, automotive equipment, traffic signaling equipment, combustion equipment, medical equipment and safety devices) in which exceptional quality and reliability are required, or if the failure or malfunction of the products may directly jeopardize life or harm the human body.
Unless exchanging documents on terms of use etc. in advance, it is to be understood that our company shall not be held responsible for any damage incurred as a result of or in connection with your using the products described in this book for any special application.
- (4) The products and product specifications described in this book are subject to change without notice for modification and/or improvement. At the final stage of your design, purchasing, or use of the products, therefore, ask for the most up-to-date Product Standards in advance to make sure that the latest specifications satisfy your requirements.
- (5) When designing your equipment, comply with the range of absolute maximum rating and the guaranteed operating conditions (operating power supply voltage and operating environment etc.). Especially, please be careful not to exceed the range of absolute maximum rating on the transient state, such as power-on, power-off and mode-switching. Otherwise, we will not be liable for any defect which may arise later in your equipment.
Even when the products are used within the guaranteed values, take into the consideration of incidence of break down and failure mode, possible to occur to semiconductor products. Measures on the systems such as redundant design, arresting the spread of fire or preventing glitch are recommended in order to prevent physical injury, fire, social damages, for example, by using the products.
- (6) Comply with the instructions for use in order to prevent breakdown and characteristics change due to external factors (ESD, EOS, thermal stress and mechanical stress) at the time of handling, mounting or at customer's process. We do not guarantee quality for disassembled products or the product re-mounted after removing from the mounting board.
When using products for which damp-proof packing is required, satisfy the conditions, such as shelf life and the elapsed time since first opening the packages.
- (7) When reselling products described in this book to other companies without our permission and receiving any claim of request from the resale destination, please understand that customers will bear the burden.
- (8) This book may be not reprinted or reproduced whether wholly or partially, without the prior written permission of our company.

X-ON Electronics

Largest Supplier of Electrical and Electronic Components

Click to view similar products for [Power Management IC Development Tools](#) category:

Click to view products by [Panasonic](#) manufacturer:

Other Similar products are found below :

[EVAL-ADM1168LQEBZ](#) [EVB-EP5348UI](#) [MIC23451-AAAYFL EV](#) [MIC5281YMME EV](#) [DA9063-EVAL](#) [ADP122-3.3-EVALZ](#) [ADP130-0.8-EVALZ](#) [ADP130-1.2-EVALZ](#) [ADP130-1.5-EVALZ](#) [ADP130-1.8-EVALZ](#) [ADP1712-3.3-EVALZ](#) [ADP1714-3.3-EVALZ](#) [ADP1715-3.3-EVALZ](#) [ADP1716-2.5-EVALZ](#) [ADP1740-1.5-EVALZ](#) [ADP1752-1.5-EVALZ](#) [ADP1828LC-EVALZ](#) [ADP1870-0.3-EVALZ](#) [ADP1871-0.6-EVALZ](#) [ADP1873-0.6-EVALZ](#) [ADP1874-0.3-EVALZ](#) [ADP1882-1.0-EVALZ](#) [ADP199CB-EVALZ](#) [ADP2102-1.25-EVALZ](#) [ADP2102-1.875EVALZ](#) [ADP2102-1.8-EVALZ](#) [ADP2102-2-EVALZ](#) [ADP2102-3-EVALZ](#) [ADP2102-4-EVALZ](#) [ADP2106-1.8-EVALZ](#) [ADP2147CB-110EVALZ](#) [AS3606-DB](#) [BQ24010EVM](#) [BQ24075TEVM](#) [BQ24155EVM](#) [BQ24157EVM-697](#) [BQ24160EVM-742](#) [BQ24296MEVM-655](#) [BQ25010EVM](#) [BQ3055EVM](#) [NCV891330PD50GEVB](#) [ISLUSBI2CKIT1Z](#) [LM2744EVAL](#) [LM2854EVAL](#) [LM3658SD-AEV/NOPB](#) [LM3658SDEV/NOPB](#) [LM3691TL-1.8EV/NOPB](#) [LM4510SDEV/NOPB](#) [LM5033SD-EVAL](#) [LP38512TS-1.8EV](#)