

AN78MxxNSP Series

3-pin positive output voltage regulator (500 mA type)

■ Overview

The AN78MxxNSP series is a 3-pin fixed positive output type monolithic voltage regulator housed in surface mounting package. Stabilized fixed output voltage is obtained from unstable DC input voltage with using minimum external components. 9 types of fixed output voltage are available; 5 V, 6 V, 7 V, 8 V, 9 V, 10 V, 12 V, 15 V and 18 V. They can be used widely in power circuits with current capacity up to 500 mA.

■ Features

- Output voltage: 5V, 6V, 7V, 8V, 9V, 10V, 12V, 15V, 18 V
- Built-in overcurrent limit circuit
- Built-in thermal overload protection circuit
- Built-in ASO (area of safe operation) protection circuit

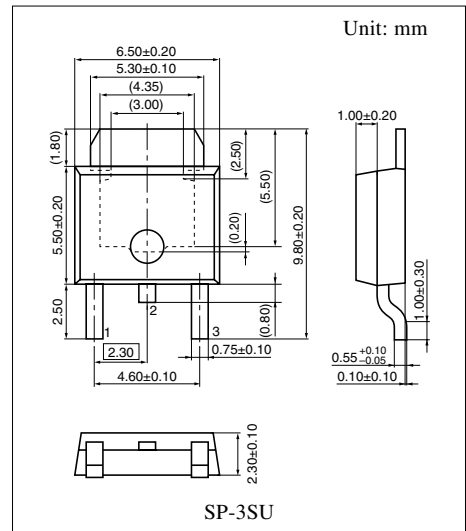

Note) The package of this product will be changed to lead-free type (SP-3SUA). See the new package dimensions section later of this datasheet.

■ Block Diagram

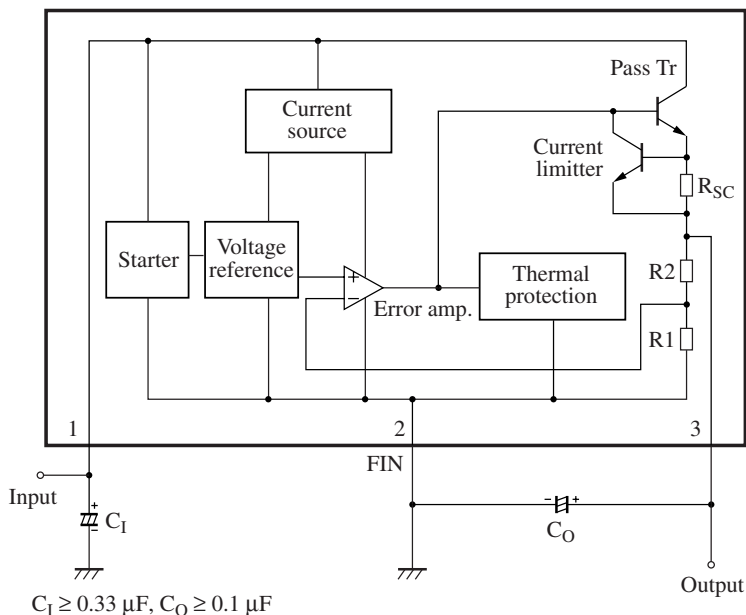

■ Pin Descriptions

Pin No.		Description
1	Input	Input voltage pin
2	GND	Ground pin (FIN)
3	Output	Output voltage pin

■ Absolute Maximum Ratings

Parameter	Symbol	Range	Unit
Supply voltage *2	V_{CC}	35	V
Supply current *3	I_{CC}	—	mA
Power dissipation *4	P_D	—	mW
Operating ambient temperature *1	T_{opr}	-30 to +85	°C
Storage temperature *1	T_{stg}	-55 to +150	°C

Note) 1. *1: Except for the operating ambient temperature and storage temperature, all ratings are for $T_a = 25^\circ\text{C}$.

*2: When V_{CC} of 35 V is applied, the overvoltage protection of ASO protection circuit may shut off the output.

*3: Since this IC has incorporated a current limiter, the current value does not exceed the rating.

*4: When T_j exceeds 150°C (designed value), the internal circuit cuts off the output. Note that the relationship between IC power dissipation and the ambient temperature must follow the derating curve.

2. This IC is not suitable for car electronics equipment.

■ Electrical Characteristics at $T_a = 25^\circ\text{C}$

• AN78M05NSP (5 V type)

The specified condition $T_j = 25^\circ\text{C}$ means that the test should be carried out within so short a test time (within 10 ms) that the characteristic value drift due to the chip junction temperature rise can be ignored.

Unless otherwise specified, $V_I = 10\text{ V}$, $I_O = 350\text{ mA}$, $C_I = 0.33\text{ }\mu\text{F}$ and $C_O = 0.1\text{ }\mu\text{F}$

Parameter	Symbol	Conditions	Min	Typ	Max	Unit
Output voltage	V_{O1}	$T_j = 25^\circ\text{C}$	4.8	5	5.2	V
Output voltage tolerance	V_{O2}	$V_I = 7.5\text{ V to }20\text{ V}$, $I_O = 5\text{ mA to }350\text{ mA}$ $T_j = 25^\circ\text{C}$	4.75	—	5.25	V
Line regulation 1	REG_{IN1}	$V_I = 7.5\text{ V to }25\text{ V}$, $T_j = 25^\circ\text{C}$	—	3	100	mV
Line regulation 2	REG_{IN2}	$V_I = 8\text{ V to }25\text{ V}$, $T_j = 25^\circ\text{C}$	—	1	50	mV
Load regulation 1	REG_{L1}	$I_O = 5\text{ mA to }500\text{ mA}$, $T_j = 25^\circ\text{C}$	—	20	100	mV
Load regulation 2	REG_{L2}	$I_O = 5\text{ mA to }200\text{ mA}$, $T_j = 25^\circ\text{C}$	—	10	50	mV
Bias current	I_{Bias}	$T_j = 25^\circ\text{C}$	—	4	6	mA
Bias current fluctuation to input	$\Delta I_{Bias(IN)}$	$V_I = 8\text{ V to }25\text{ V}$, $T_j = 25^\circ\text{C}$	—	—	0.8	mA
Bias current fluctuation to load	$\Delta I_{Bias(L)}$	$I_O = 5\text{ mA to }350\text{ mA}$, $T_j = 25^\circ\text{C}$	—	—	0.5	mA
Ripple rejection ratio	RR	$V_I = 8\text{ V to }18\text{ V}$, $I_O = 100\text{ mA}$, $f = 120\text{ Hz}$	62	—	—	dB

• Design reference data

Note) The characteristics listed below are theoretical values based on the IC design and are not guaranteed.

Parameter	Symbol	Conditions	Min	Typ	Max	Unit
Output noise voltage	V_{NO}	$f = 10\text{ Hz to }100\text{ kHz}$	—	40	—	μV
Minimum input/output voltage difference	$V_{DIF(min)}$	$I_O = 500\text{ mA}$, $T_j = 25^\circ\text{C}$	—	2	—	V
Output short-circuit current	$I_{O(Short)}$	$V_I = 35\text{ V}$, $T_j = 25^\circ\text{C}$	—	300	—	mA
Peak output current	$I_{O(Peak)}$	$T_j = 25^\circ\text{C}$	—	1000	—	mA
Output voltage temperature coefficient	$\Delta V_O / T_a$	$I_O = 5\text{ mA}$, $T_j = 0^\circ\text{C to }125^\circ\text{C}$	—	-0.5	—	$\text{mV}/^\circ\text{C}$
Thermal protection operating temperature	$T_{j(TH)}$	$I_O = 5\text{ mA}$	—	150	—	°C

■ Electrical Characteristics at $T_a = 25^\circ\text{C}$ (continued)

• AN78M06NSP (6 V type)

The specified condition $T_j = 25^\circ\text{C}$ means that the test should be carried out within so short a test time (within 10 ms) that the characteristic value drift due to the chip junction temperature rise can be ignored.

Unless otherwise specified, $V_I = 11\text{ V}$, $I_O = 350\text{ mA}$, $C_I = 0.33\text{ }\mu\text{F}$ and $C_O = 0.1\text{ }\mu\text{F}$

Parameter	Symbol	Conditions	Min	Typ	Max	Unit
Output voltage	V_{O1}	$T_j = 25^\circ\text{C}$	5.75	6	6.25	V
Output voltage tolerance	V_{O2}	$V_I = 8.5\text{ V to }21\text{ V}$, $I_O = 5\text{ mA to }350\text{ mA}$ $T_j = 25^\circ\text{C}$	5.7	—	6.3	V
Line regulation 1	$\text{REG}_{\text{IN}1}$	$V_I = 8.5\text{ V to }25\text{ V}$, $T_j = 25^\circ\text{C}$	—	5	100	mV
Line regulation 2	$\text{REG}_{\text{IN}2}$	$V_I = 9\text{ V to }25\text{ V}$, $T_j = 25^\circ\text{C}$	—	1.5	50	mV
Load regulation 1	$\text{REG}_{\text{L}1}$	$I_O = 5\text{ mA to }500\text{ mA}$, $T_j = 25^\circ\text{C}$	—	20	120	mV
Load regulation 2	$\text{REG}_{\text{L}2}$	$I_O = 5\text{ mA to }200\text{ mA}$, $T_j = 25^\circ\text{C}$	—	10	60	mV
Bias current	I_{Bias}	$T_j = 25^\circ\text{C}$	—	4	6	mA
Bias current fluctuation to input	$\Delta I_{\text{Bias}(\text{IN})}$	$V_I = 9\text{ V to }25\text{ V}$, $T_j = 25^\circ\text{C}$	—	—	0.8	mA
Bias current fluctuation to load	$\Delta I_{\text{Bias}(\text{L})}$	$I_O = 5\text{ mA to }350\text{ mA}$, $T_j = 25^\circ\text{C}$	—	—	0.5	mA
Ripple rejection ratio	RR	$V_I = 9\text{ V to }19\text{ V}$, $I_O = 100\text{ mA}$, $f = 120\text{ Hz}$	59	—	—	dB

• Design reference data

Note) The characteristics listed below are theoretical values based on the IC design and are not guaranteed.

Parameter	Symbol	Conditions	Min	Typ	Max	Unit
Output noise voltage	V_{NO}	$f = 10\text{ Hz to }100\text{ kHz}$	—	45	—	μV
Minimum input/output voltage difference	$V_{\text{DIF}(\text{min})}$	$I_O = 500\text{ mA}$, $T_j = 25^\circ\text{C}$	—	2	—	V
Output short-circuit current	$I_{\text{O}(\text{Short})}$	$V_I = 35\text{ V}$, $T_j = 25^\circ\text{C}$	—	300	—	mA
Peak output current	$I_{\text{O}(\text{Peak})}$	$T_j = 25^\circ\text{C}$	—	1000	—	mA
Output voltage temperature coefficient	$\Delta V_O / T_a$	$I_O = 5\text{ mA}$, $T_j = 0^\circ\text{C to }125^\circ\text{C}$	—	-0.5	—	$\text{mV}/^\circ\text{C}$
Thermal protection operating temperature	$T_{\text{j}(\text{TH})}$	$I_O = 5\text{ mA}$	—	150	—	$^\circ\text{C}$

■ Electrical Characteristics at $T_a = 25^\circ\text{C}$ (continued)

• AN78M07NSP (7 V type)

The specified condition $T_j = 25^\circ\text{C}$ means that the test should be carried out within so short a test time (within 10 ms) that the characteristic value drift due to the chip junction temperature rise can be ignored.

Unless otherwise specified, $V_I = 12\text{ V}$, $I_O = 350\text{ mA}$, $C_I = 0.33\text{ }\mu\text{F}$ and $C_O = 0.1\text{ }\mu\text{F}$

Parameter	Symbol	Conditions	Min	Typ	Max	Unit
Output voltage	V_{O1}	$T_j = 25^\circ\text{C}$	6.7	7	7.3	V
Output voltage tolerance	V_{O2}	$V_I = 9.5\text{ V to }22\text{ V}$, $I_O = 5\text{ mA to }350\text{ mA}$ $T_j = 25^\circ\text{C}$	6.65	—	7.35	V
Line regulation 1	REG_{IN1}	$V_I = 9.5\text{ V to }25\text{ V}$, $T_j = 25^\circ\text{C}$	—	6	100	mV
Line regulation 2	REG_{IN2}	$V_I = 10\text{ V to }25\text{ V}$, $T_j = 25^\circ\text{C}$	—	2	50	mV
Load regulation 1	REG_{L1}	$I_O = 5\text{ mA to }500\text{ mA}$, $T_j = 25^\circ\text{C}$	—	20	140	mV
Load regulation 2	REG_{L2}	$I_O = 5\text{ mA to }200\text{ mA}$, $T_j = 25^\circ\text{C}$	—	10	70	mV
Bias current	I_{Bias}	$T_j = 25^\circ\text{C}$	—	4	6	mA
Bias current fluctuation to input	$\Delta I_{\text{Bias(IN)}}$	$V_I = 10\text{ V to }25\text{ V}$, $T_j = 25^\circ\text{C}$	—	—	0.8	mA
Bias current fluctuation to load	$\Delta I_{\text{Bias(L)}}$	$I_O = 5\text{ mA to }350\text{ mA}$, $T_j = 25^\circ\text{C}$	—	—	0.5	mA
Ripple rejection ratio	RR	$V_I = 10\text{ V to }20\text{ V}$, $I_O = 100\text{ mA}$, $f = 120\text{ Hz}$	57	—	—	dB

• Design reference data

Note) The characteristics listed below are theoretical values based on the IC design and are not guaranteed.

Parameter	Symbol	Conditions	Min	Typ	Max	Unit
Output noise voltage	V_{NO}	$f = 10\text{ Hz to }100\text{ kHz}$	—	48	—	μV
Minimum input/output voltage difference	$V_{\text{DIF(min)}}$	$I_O = 500\text{ mA}$, $T_j = 25^\circ\text{C}$	—	2	—	V
Output short-circuit current	$I_{\text{O(Short)}}$	$V_I = 35\text{ V}$, $T_j = 25^\circ\text{C}$	—	300	—	mA
Peak output current	$I_{\text{O(Peak)}}$	$T_j = 25^\circ\text{C}$	—	1000	—	mA
Output voltage temperature coefficient	$\Delta V_O / T_a$	$I_O = 5\text{ mA}$, $T_j = 0^\circ\text{C to }125^\circ\text{C}$	—	-0.5	—	$\text{mV}/^\circ\text{C}$
Thermal protection operating temperature	$T_{\text{j(TH)}}$	$I_O = 5\text{ mA}$	—	150	—	$^\circ\text{C}$

■ Electrical Characteristics at $T_a = 25^\circ\text{C}$ (continued)

• AN78M08NSP (8 V type)

The specified condition $T_j = 25^\circ\text{C}$ means that the test should be carried out within so short a test time (within 10 ms) that the characteristic value drift due to the chip junction temperature rise can be ignored.

Unless otherwise specified, $V_I = 14\text{ V}$, $I_O = 350\text{ mA}$, $C_I = 0.33\text{ }\mu\text{F}$ and $C_O = 0.1\text{ }\mu\text{F}$

Parameter	Symbol	Conditions	Min	Typ	Max	Unit
Output voltage	V_{O1}	$T_j = 25^\circ\text{C}$	7.7	8	8.3	V
Output voltage tolerance	V_{O2}	$V_I = 10.5\text{ V to }22\text{ V}$, $I_O = 5\text{ mA to }350\text{ mA}$ $T_j = 25^\circ\text{C}$	7.6	—	8.4	V
Line regulation 1	$\text{REG}_{\text{IN}1}$	$V_I = 10.5\text{ V to }25\text{ V}$, $T_j = 25^\circ\text{C}$	—	6	100	mV
Line regulation 2	$\text{REG}_{\text{IN}2}$	$V_I = 11\text{ V to }25\text{ V}$, $T_j = 25^\circ\text{C}$	—	2	50	mV
Load regulation 1	$\text{REG}_{\text{L}1}$	$I_O = 5\text{ mA to }500\text{ mA}$, $T_j = 25^\circ\text{C}$	—	25	160	mV
Load regulation 2	$\text{REG}_{\text{L}2}$	$I_O = 5\text{ mA to }200\text{ mA}$, $T_j = 25^\circ\text{C}$	—	10	80	mV
Bias current	I_{Bias}	$T_j = 25^\circ\text{C}$	—	4.1	6	mA
Bias current fluctuation to input	$\Delta I_{\text{Bias}(\text{IN})}$	$V_I = 10.5\text{ V to }25\text{ V}$, $T_j = 25^\circ\text{C}$	—	—	0.8	mA
Bias current fluctuation to load	$\Delta I_{\text{Bias}(\text{L})}$	$I_O = 5\text{ mA to }350\text{ mA}$, $T_j = 25^\circ\text{C}$	—	—	0.5	mA
Ripple rejection ratio	RR	$V_I = 11.5\text{ V to }21.5\text{ V}$, $I_O = 100\text{ mA}$, $f = 120\text{ Hz}$	56	—	—	dB

• Design reference data

Note) The characteristics listed below are theoretical values based on the IC design and are not guaranteed.

Parameter	Symbol	Conditions	Min	Typ	Max	Unit
Output noise voltage	V_{NO}	$f = 10\text{ Hz to }100\text{ kHz}$	—	48	—	μV
Minimum input/output voltage difference	$V_{\text{DIF}(\text{min})}$	$I_O = 500\text{ mA}$, $T_j = 25^\circ\text{C}$	—	2	—	V
Output short-circuit current	$I_{\text{O}(\text{Short})}$	$V_I = 35\text{ V}$, $T_j = 25^\circ\text{C}$	—	300	—	mA
Peak output current	$I_{\text{O}(\text{Peak})}$	$T_j = 25^\circ\text{C}$	—	1000	—	mA
Output voltage temperature coefficient	$\Delta V_O / T_a$	$I_O = 5\text{ mA}$, $T_j = 0^\circ\text{C to }125^\circ\text{C}$	—	-0.5	—	$\text{mV}/^\circ\text{C}$
Thermal protection operating temperature	$T_{\text{j}(\text{TH})}$	$I_O = 5\text{ mA}$	—	150	—	$^\circ\text{C}$

■ Electrical Characteristics at $T_a = 25^\circ\text{C}$ (continued)

• AN78M09NSP (9 V type)

The specified condition $T_j = 25^\circ\text{C}$ means that the test should be carried out within so short a test time (within 10 ms) that the characteristic value drift due to the chip junction temperature rise can be ignored.

Unless otherwise specified, $V_1 = 15\text{ V}$, $I_O = 350\text{ mA}$, $C_1 = 0.33\text{ }\mu\text{F}$ and $C_O = 0.1\text{ }\mu\text{F}$

Parameter	Symbol	Conditions	Min	Typ	Max	Unit
Output voltage	V_{O1}	$T_j = 25^\circ\text{C}$	8.65	9	9.35	V
Output voltage tolerance	V_{O2}	$V_1 = 11.5\text{ V to }24\text{ V}$, $I_O = 5\text{ mA to }350\text{ mA}$ $T_j = 25^\circ\text{C}$	8.55	—	9.45	V
Line regulation 1	REG_{IN1}	$V_1 = 11.5\text{ V to }25\text{ V}$, $T_j = 25^\circ\text{C}$	—	7	100	mV
Line regulation 2	REG_{IN2}	$V_1 = 12\text{ V to }25\text{ V}$, $T_j = 25^\circ\text{C}$	—	2	50	mV
Load regulation 1	REG_{L1}	$I_O = 5\text{ mA to }500\text{ mA}$, $T_j = 25^\circ\text{C}$	—	25	180	mV
Load regulation 2	REG_{L2}	$I_O = 5\text{ mA to }200\text{ mA}$, $T_j = 25^\circ\text{C}$	—	10	90	mV
Bias current	I_{Bias}	$T_j = 25^\circ\text{C}$	—	4.1	6	mA
Bias current fluctuation to input	$\Delta I_{\text{Bias(IN)}}$	$V_1 = 12\text{ V to }25\text{ V}$, $T_j = 25^\circ\text{C}$	—	—	0.8	mA
Bias current fluctuation to load	$\Delta I_{\text{Bias(L)}}$	$I_O = 5\text{ mA to }350\text{ mA}$, $T_j = 25^\circ\text{C}$	—	—	0.5	mA
Ripple rejection ratio	RR	$V_1 = 12\text{ V to }22\text{ V}$, $I_O = 100\text{ mA}$, $f = 120\text{ Hz}$	56	—	—	dB

• Design reference data

Note) The characteristics listed below are theoretical values based on the IC design and are not guaranteed.

Parameter	Symbol	Conditions	Min	Typ	Max	Unit
Output noise voltage	V_{NO}	$f = 10\text{ Hz to }100\text{ kHz}$	—	60	—	μV
Minimum input/output voltage difference	$V_{\text{DIF(min)}}$	$I_O = 500\text{ mA}$, $T_j = 25^\circ\text{C}$	—	2	—	V
output short-circuit current	$I_{\text{O(Short)}}$	$V_1 = 35\text{ V}$, $T_j = 25^\circ\text{C}$	—	300	—	mA
Peak output current	$I_{\text{O(Peak)}}$	$T_j = 25^\circ\text{C}$	—	1000	—	mA
Output voltage temperature coefficient	$\Delta V_O / T_a$	$I_O = 5\text{ mA}$, $T_j = 0^\circ\text{C to }125^\circ\text{C}$	—	-0.5	—	$\text{mV}/^\circ\text{C}$
Thermal protection operating temperature	$T_{\text{j(TH)}}$	$I_O = 5\text{ mA}$	—	150	—	$^\circ\text{C}$

■ Electrical Characteristics at $T_a = 25^\circ\text{C}$ (continued)

• AN78M10NSP (10 V type)

The specified condition $T_j = 25^\circ\text{C}$ means that the test should be carried out within so short a test time (within 10 ms) that the characteristic value drift due to the chip junction temperature rise can be ignored.

Unless otherwise specified, $V_1 = 16\text{ V}$, $I_O = 350\text{ mA}$, $C_1 = 0.33\text{ }\mu\text{F}$ and $C_O = 0.1\text{ }\mu\text{F}$

Parameter	Symbol	Conditions	Min	Typ	Max	Unit
Output voltage	V_{O1}	$T_j = 25^\circ\text{C}$	9.6	10	10.4	V
Output voltage tolerance	V_{O2}	$V_1 = 12.5\text{ V to }25\text{ V}$, $I_O = 5\text{ mA to }350\text{ mA}$ $T_j = 25^\circ\text{C}$	9.5	—	10.5	V
Line regulation 1	REG_{IN1}	$V_1 = 12.5\text{ V to }30\text{ V}$, $T_j = 25^\circ\text{C}$	—	7	100	mV
Line regulation 2	REG_{IN2}	$V_1 = 13\text{ V to }25\text{ V}$, $T_j = 25^\circ\text{C}$	—	2	50	mV
Load regulation 1	REG_{L1}	$I_O = 5\text{ mA to }500\text{ mA}$, $T_j = 25^\circ\text{C}$	—	25	200	mV
Load regulation 2	REG_{L2}	$I_O = 5\text{ mA to }200\text{ mA}$, $T_j = 25^\circ\text{C}$	—	10	100	mV
Bias current	I_{Bias}	$T_j = 25^\circ\text{C}$	—	4.1	6	mA
Bias current fluctuation to input	$\Delta I_{Bias(IN)}$	$V_1 = 13\text{ V to }25\text{ V}$, $T_j = 25^\circ\text{C}$	—	—	0.8	mA
Bias current fluctuation to load	$\Delta I_{Bias(L)}$	$I_O = 5\text{ mA to }350\text{ mA}$, $T_j = 25^\circ\text{C}$	—	—	0.5	mA
Ripple rejection ratio	RR	$V_1 = 13\text{ V to }23\text{ V}$, $I_O = 100\text{ mA}$, $f = 120\text{ Hz}$	56	—	—	dB

• Design reference data

Note) The characteristics listed below are theoretical values based on the IC design and are not guaranteed.

Parameter	Symbol	Conditions	Min	Typ	Max	Unit
Output noise voltage	V_{NO}	$f = 10\text{ Hz to }100\text{ kHz}$	—	65	—	μV
Minimum input/output voltage difference	$V_{DIF(min)}$	$I_O = 500\text{ mA}$, $T_j = 25^\circ\text{C}$	—	2	—	V
Output short-circuit current	$I_{O(Short)}$	$V_1 = 35\text{ V}$, $T_j = 25^\circ\text{C}$	—	300	—	mA
Peak output current	$I_{O(Peak)}$	$T_j = 25^\circ\text{C}$	—	1000	—	mA
Output voltage temperature coefficient	$\Delta V_O / T_a$	$I_O = 5\text{ mA}$, $T_j = 0^\circ\text{C to }125^\circ\text{C}$	—	-0.5	—	$\text{mV}/^\circ\text{C}$
Thermal protection operating temperature	$T_{j(TH)}$	$I_O = 5\text{ mA}$	—	150	—	$^\circ\text{C}$

■ Electrical Characteristics at $T_a = 25^\circ\text{C}$ (continued)

• AN78M12NSP (12 V type)

The specified condition $T_j = 25^\circ\text{C}$ means that the test should be carried out within so short a test time (within 10 ms) that the characteristic value drift due to the chip junction temperature rise can be ignored.

Unless otherwise specified, $V_I = 19\text{ V}$, $I_O = 350\text{ mA}$, $C_I = 0.33\text{ }\mu\text{F}$ and $C_O = 0.1\text{ }\mu\text{F}$

Parameter	Symbol	Conditions	Min	Typ	Max	Unit
Output voltage	V_{O1}	$T_j = 25^\circ\text{C}$	11.5	12	12.5	V
Output voltage tolerance	V_{O2}	$V_I = 14.5\text{ V to }27\text{ V}$, $I_O = 5\text{ mA to }350\text{ mA}$ $T_j = 25^\circ\text{C}$	11.4	—	12.6	V
Line regulation 1	$\text{REG}_{\text{IN}1}$	$V_I = 14.5\text{ V to }30\text{ V}$, $T_j = 25^\circ\text{C}$	—	8	100	mV
Line regulation 2	$\text{REG}_{\text{IN}2}$	$V_I = 16\text{ V to }30\text{ V}$, $T_j = 25^\circ\text{C}$	—	2	50	mV
Load regulation 1	$\text{REG}_{\text{L}1}$	$I_O = 5\text{ mA to }500\text{ mA}$, $T_j = 25^\circ\text{C}$	—	25	240	mV
Load regulation 2	$\text{REG}_{\text{L}2}$	$I_O = 5\text{ mA to }200\text{ mA}$, $T_j = 25^\circ\text{C}$	—	10	120	mV
Bias current	I_{Bias}	$T_j = 25^\circ\text{C}$	—	4.3	6	mA
Bias current fluctuation to input	$\Delta I_{\text{Bias}(\text{IN})}$	$V_I = 14.5\text{ V to }30\text{ V}$, $T_j = 25^\circ\text{C}$	—	—	0.8	mA
Bias current fluctuation to load	$\Delta I_{\text{Bias}(\text{L})}$	$I_O = 5\text{ mA to }350\text{ mA}$, $T_j = 25^\circ\text{C}$	—	—	0.5	mA
Ripple rejection ratio	RR	$V_I = 15\text{ V to }25\text{ V}$, $I_O = 100\text{ mA}$, $f = 120\text{ Hz}$	55	—	—	dB

• Design reference data

Note) The characteristics listed below are theoretical values based on the IC design and are not guaranteed.

Parameter	Symbol	Conditions	Min	Typ	Max	Unit
Output noise voltage	V_{NO}	$f = 10\text{ Hz to }100\text{ kHz}$	—	75	—	μV
Minimum input/output voltage difference	$V_{\text{DIF}(\text{min})}$	$I_O = 500\text{ mA}$, $T_j = 25^\circ\text{C}$	—	2	—	V
Output short-circuit current	$I_{\text{O}(\text{Short})}$	$V_I = 35\text{ V}$, $T_j = 25^\circ\text{C}$	—	300	—	mA
Peak output current	$I_{\text{O}(\text{Peak})}$	$T_j = 25^\circ\text{C}$	—	1000	—	mA
Output voltage temperature coefficient	$\Delta V_O / T_a$	$I_O = 5\text{ mA}$, $T_j = 0^\circ\text{C to }125^\circ\text{C}$	—	-0.5	—	$\text{mV}/^\circ\text{C}$
Thermal protection operating temperature	$T_{\text{j}(\text{TH})}$	$I_O = 5\text{ mA}$	—	150	—	$^\circ\text{C}$

■ Electrical Characteristics at $T_a = 25^\circ\text{C}$ (continued)

• AN78M15NSP (15 V type)

The specified condition $T_j = 25^\circ\text{C}$ means that the test should be carried out within so short a test time (within 10 ms) that the characteristic value drift due to the chip junction temperature rise can be ignored.

Unless otherwise specified, $V_I = 23\text{ V}$, $I_O = 350\text{ mA}$, $C_I = 0.33\text{ }\mu\text{F}$ and $C_O = 0.1\text{ }\mu\text{F}$

Parameter	Symbol	Conditions	Min	Typ	Max	Unit
Output voltage	V_{O1}	$T_j = 25^\circ\text{C}$	14.4	15	15.6	V
Output voltage tolerance	V_{O2}	$V_I = 17.5\text{ V to }30\text{ V}$, $I_O = 5\text{ mA to }350\text{ mA}$ $T_j = 25^\circ\text{C}$	14.25	—	15.75	V
Line regulation 1	REG_{IN1}	$V_I = 17.5\text{ V to }30\text{ V}$, $T_j = 25^\circ\text{C}$	—	10	100	mV
Line regulation 2	REG_{IN2}	$V_I = 20\text{ V to }30\text{ V}$, $T_j = 25^\circ\text{C}$	—	3	50	mV
Load regulation 1	REG_{L1}	$I_O = 5\text{ mA to }500\text{ mA}$, $T_j = 25^\circ\text{C}$	—	25	300	mV
Load regulation 2	REG_{L2}	$I_O = 5\text{ mA to }200\text{ mA}$, $T_j = 25^\circ\text{C}$	—	10	150	mV
Bias current	I_{Bias}	$T_j = 25^\circ\text{C}$	—	4.3	6	mA
Bias current fluctuation to input	$\Delta I_{\text{Bias(IN)}}$	$V_I = 17.5\text{ V to }30\text{ V}$, $T_j = 25^\circ\text{C}$	—	—	0.8	mA
Bias current fluctuation to load	$\Delta I_{\text{Bias(L)}}$	$I_O = 5\text{ mA to }350\text{ mA}$, $T_j = 25^\circ\text{C}$	—	—	0.5	mA
Ripple rejection ratio	RR	$V_I = 18.5\text{ V to }28.5\text{ V}$, $I_O = 100\text{ mA}$, $f = 120\text{ Hz}$	54	—	—	dB

• Design reference data

Note) The characteristics listed below are theoretical values based on the IC design and are not guaranteed.

Parameter	Symbol	Conditions	Min	Typ	Max	Unit
Output noise voltage	V_{NO}	$f = 10\text{ Hz to }100\text{ kHz}$	—	90	—	μV
Minimum input/output voltage difference	$V_{\text{DIF(min)}}$	$I_O = 500\text{ mA}$, $T_j = 25^\circ\text{C}$	—	2	—	V
Output short-circuit current	$I_{\text{O(Short)}}$	$V_I = 35\text{ V}$, $T_j = 25^\circ\text{C}$	—	300	—	mA
Peak output current	$I_{\text{O(Peak)}}$	$T_j = 25^\circ\text{C}$	—	1000	—	mA
Output voltage temperature coefficient	$\Delta V_O / T_a$	$I_O = 5\text{ mA}$, $T_j = 0^\circ\text{C to }125^\circ\text{C}$	—	-0.5	—	$\text{mV}/^\circ\text{C}$
Thermal protection operating temperature	$T_{\text{j(TH)}}$	$I_O = 5\text{ mA}$	—	150	—	$^\circ\text{C}$

■ Electrical Characteristics at $T_a = 25^\circ\text{C}$ (continued)

• AN78M18NSP (18 V type)

The specified condition $T_j = 25^\circ\text{C}$ means that the test should be carried out within so short a test time (within 10 ms) that the characteristic value drift due to the chip junction temperature rise can be ignored.

Unless otherwise specified, $V_I = 27\text{ V}$, $I_O = 350\text{ mA}$, $C_I = 0.33\text{ }\mu\text{F}$ and $C_O = 0.1\text{ }\mu\text{F}$

Parameter	Symbol	Conditions	Min	Typ	Max	Unit
Output voltage	V_{O1}	$T_j = 25^\circ\text{C}$	17.3	18	18.7	V
Output voltage tolerance	V_{O2}	$V_I = 21\text{ V to }33\text{ V}$, $I_O = 5\text{ mA to }350\text{ mA}$ $T_j = 25^\circ\text{C}$	17.1	—	18.9	V
Line regulation 1	$\text{REG}_{\text{IN}1}$	$V_I = 21\text{ V to }33\text{ V}$, $T_j = 25^\circ\text{C}$	—	10	100	mV
Line regulation 2	$\text{REG}_{\text{IN}2}$	$V_I = 22\text{ V to }33\text{ V}$, $T_j = 25^\circ\text{C}$	—	5	50	mV
Load regulation 1	$\text{REG}_{\text{L}1}$	$I_O = 5\text{ mA to }500\text{ mA}$, $T_j = 25^\circ\text{C}$	—	30	360	mV
Load regulation 2	$\text{REG}_{\text{L}2}$	$I_O = 5\text{ mA to }200\text{ mA}$, $T_j = 25^\circ\text{C}$	—	10	180	mV
Bias current	I_{Bias}	$T_j = 25^\circ\text{C}$	—	4.4	6	mA
Bias current fluctuation to input	$\Delta I_{\text{Bias}(\text{IN})}$	$V_I = 21\text{ V to }33\text{ V}$, $T_j = 25^\circ\text{C}$	—	—	0.8	mA
Bias current fluctuation to load	$\Delta I_{\text{Bias}(\text{L})}$	$I_O = 5\text{ mA to }350\text{ mA}$, $T_j = 25^\circ\text{C}$	—	—	0.5	mA
Ripple rejection ratio	RR	$V_I = 22\text{ V to }32\text{ V}$, $I_O = 100\text{ mA}$, $f = 120\text{ Hz}$	53	—	—	dB

• Design reference data

Note) The characteristics listed below are theoretical values based on the IC design and are not guaranteed.

Parameter	Symbol	Conditions	Min	Typ	Max	Unit
Output noise voltage	V_{NO}	$f = 10\text{ Hz to }100\text{ kHz}$	—	100	—	μV
Minimum input/output voltage difference	$V_{\text{DIF}(\text{min})}$	$I_O = 500\text{ mA}$, $T_j = 25^\circ\text{C}$	—	2	—	V
Output short-circuit current	$I_{\text{O}(\text{Short})}$	$V_I = 35\text{ V}$, $T_j = 25^\circ\text{C}$	—	300	—	mA
Peak output current	$I_{\text{O}(\text{Peak})}$	$T_j = 25^\circ\text{C}$	—	1000	—	mA
Output voltage temperature coefficient	$\Delta V_O / T_a$	$I_O = 5\text{ mA}$, $T_j = 0^\circ\text{C to }125^\circ\text{C}$	—	-0.5	—	$\text{mV}/^\circ\text{C}$
Thermal protection operating temperature	$T_{\text{j}(\text{TH})}$	$I_O = 5\text{ mA}$	—	150	—	$^\circ\text{C}$

■ Application Notes

1. $P_D - T_a$ curves of SP-3SU

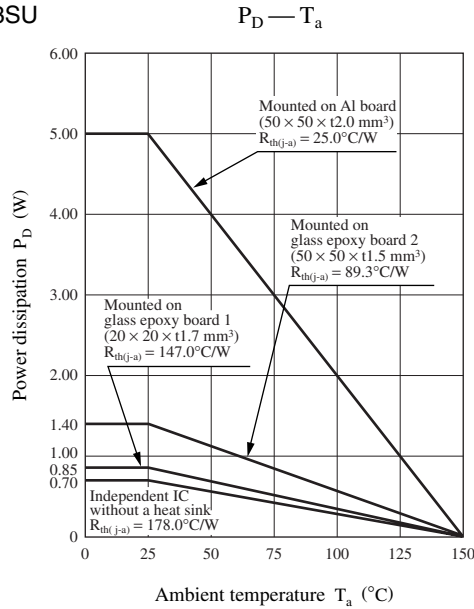

2. Main Characteristics

Output voltage temperature characteristic

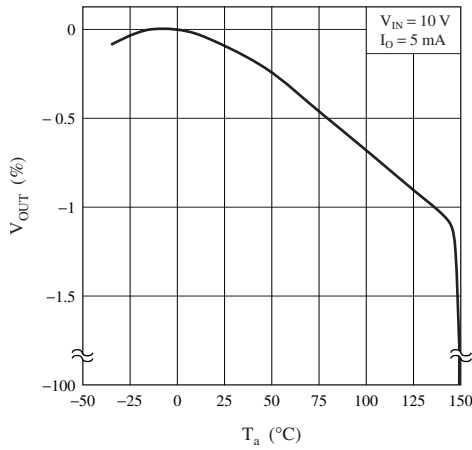

Minimum input/output voltage difference vs. load current characteristic

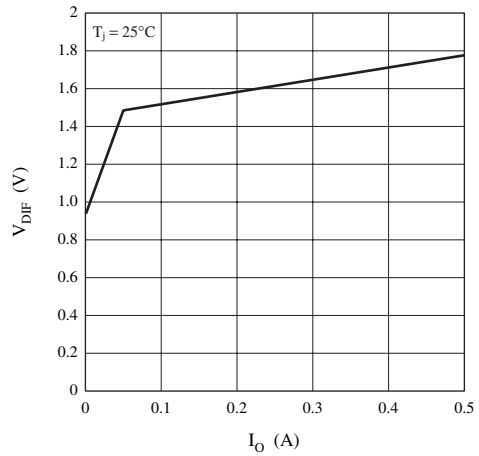

Current limit characteristics

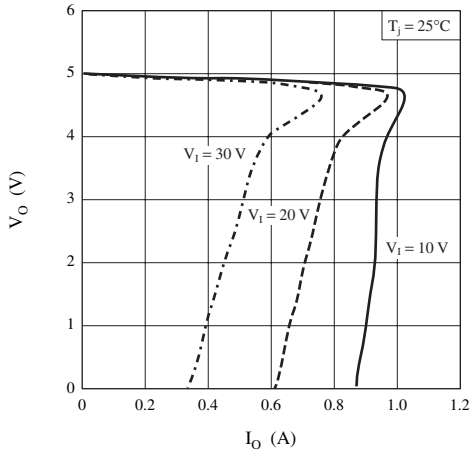

Ripple rejection ratio vs. frequency characteristic

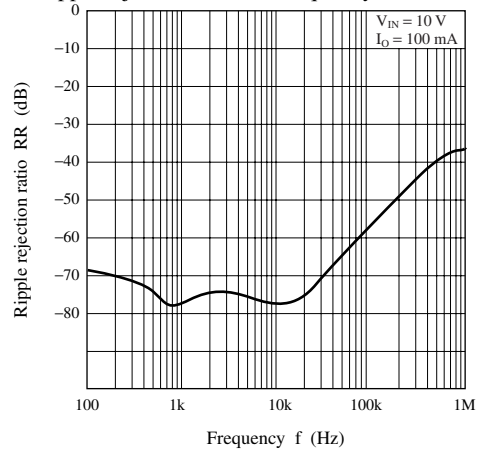

Request for your special attention and precautions in using the technical information and semiconductors described in this material

- (1) An export permit needs to be obtained from the competent authorities of the Japanese Government if any of the products or technologies described in this material and controlled under the "Foreign Exchange and Foreign Trade Law" is to be exported or taken out of Japan.
- (2) The technical information described in this material is limited to showing representative characteristics and applied circuit examples of the products. It does not constitute the warranting of industrial property, the granting of relative rights, or the granting of any license.
- (3) The products described in this material are intended to be used for standard applications or general electronic equipment (such as office equipment, communications equipment, measuring instruments and household appliances).
Consult our sales staff in advance for information on the following applications:
 - Special applications (such as for airplanes, aerospace, automobiles, traffic control equipment, combustion equipment, life support systems and safety devices) in which exceptional quality and reliability are required, or if the failure or malfunction of the products may directly jeopardize life or harm the human body.
 - Any applications other than the standard applications intended.
- (4) The products and product specifications described in this material are subject to change without notice for reasons of modification and/or improvement. At the final stage of your design, purchasing, or use of the products, therefore, ask for the most up-to-date Product Standards in advance to make sure that the latest specifications satisfy your requirements.
- (5) When designing your equipment, comply with the guaranteed values, in particular those of maximum rating, the range of operating power supply voltage and heat radiation characteristics. Otherwise, we will not be liable for any defect which may arise later in your equipment.
Even when the products are used within the guaranteed values, redundant design is recommended, so that such equipment may not violate relevant laws or regulations because of the function of our products.
- (6) When using products for which dry packing is required, observe the conditions (including shelf life and after-unpacking standby time) agreed upon when specification sheets are individually exchanged.
- (7) No part of this material may be reprinted or reproduced by any means without written permission from our company.

Please read the following notes before using the datasheets

- A. These materials are intended as a reference to assist customers with the selection of Panasonic semiconductor products best suited to their applications.
Due to modification or other reasons, any information contained in this material, such as available product types, technical data, and so on, is subject to change without notice.
Customers are advised to contact our semiconductor sales office and obtain the latest information before starting precise technical research and/or purchasing activities.
- B. Panasonic is endeavoring to continually improve the quality and reliability of these materials but there is always the possibility that further rectifications will be required in the future. Therefore, Panasonic will not assume any liability for any damages arising from any errors etc. that may appear in this material.
- C. These materials are solely intended for a customer's individual use.
Therefore, without the prior written approval of Panasonic, any other use such as reproducing, selling, or distributing this material to a third party, via the Internet or in any other way, is prohibited.

X-ON Electronics

Largest Supplier of Electrical and Electronic Components

Click to view similar products for [panasonic](#) manufacturer:

Other Similar products are found below :

[ECE-A1HKAR47](#) [ELC-09D151F](#) [HC2-H-DC48V-F](#) [HL2-HP-AC120V-F](#) [HL2-H-DC12V-F](#) [HL2-HP-DC12V-F](#) [HL2-HP-DC6V-F](#) [HL2-HP-DC24V-F](#) [HL2-H-DC110V-F](#) [HC4-H-DC24V](#) [HL2-HTM-DC24V-F](#) [HL2-HTM-AC24V-F](#) [HC4-H-AC24V](#) [HC4-H-AC120V](#) [HC4-H-DC12V](#) [AZH2031](#) [RP-SDMF64DA1](#) [EVM-F6SA00B55](#) [RP-SMLE08DA1](#) [ERZ-V20R391](#) [ELL-ATV681M](#) [ERZ-V05V680CB](#) [LT4H-DC24V](#) [LT4HL8-AC24V](#) [LT4HW-AC24V](#) [LT4HWT8-AC240V](#) [LT4HWT-AC240VS](#) [CY-122A-P](#) [ETQ-P5M470YFM](#) [EVAL_PAN1555](#) [EVQ-PAE04M](#) [EX-14B](#) [EX-22B-PN](#) [EX-31A-C5](#) [EXB-24N121JX](#) [EX-F72-PN](#) [EX-L211](#) [EYG-A121803V](#) [FCR-M50-AC208V](#) [FC-SFBH-20](#) [FC-SFBH-24](#) [FD-F8Y](#) [MHMA102A1C](#) [MHMD022S1S](#) [MHMD041S1S](#) [MHMD042G1T](#) [MHMD082G1T](#) [FD-S9](#) [FP0-LDR](#) [FP2-AD8X](#)